



# DCM-500B\_H-OS

## OPTI-SERVE SERIES SANITARY CUBELET ICE MACHINE/DISPENSER



DCM-500B\_H-OS  
07/02/24 Item #  
13147

Item #: \_\_\_\_\_  
 Project: \_\_\_\_\_  
 Qty: \_\_\_\_\_  
 AIA#: \_\_\_\_\_

### Features

- ▶ Durable stainless steel exterior
- ▶ Advanced CleanCycle24™ design 
- ▶ Stainless steel auger with greaseless bearing

- Up to 618 lbs. of ice production per 24 hours
- Built-in storage capacity of 1.3ft<sup>3</sup>/40 lbs.\*
- 2 second flush cycle every hour
- Corrosion resistant stainless steel exterior
- Easy to chew, cubelet ice
- Self-contained design reduces opportunities for cross contamination
- Dispenses ice and water
- R-404A Refrigerant

### Warranty:

3 Year Parts & Labor on entire machine.  
 5 Year Parts on Compressor; air-cooled condenser coil.  
 Valid in United States, Canada, Puerto Rico and U.S. Territories. Contact factory for warranty in other countries.

\*Rated in accordance with AHRI Standard 820(I-P). Capacity based on 100% of total volume x 30 lb/ft<sup>3</sup> average density of ice.

Shipping: (LxWxH) 33" x 25.25" X 46"    Volume: 22.18ft<sup>3</sup>

**W x D x H**  
 26" x 22<sup>1</sup>/<sub>2</sub>" x 40"  
**SD-500**  
 25<sup>9</sup>/<sub>10</sub>" x 22" x 32<sup>3</sup>/<sub>4</sub>"



### DCM-500BAH-OS

Air-Cooled  
 Shown with optional  
 SD-500 Stand

### DCM-500BWH-OS

Water-Cooled

*\*Hands-free sensor designed for use with opaque containers.  
 Not intended for outdoor use - avoid placement in direct sunlight.*



Condenser	Model	ICE PRODUCTION		WATER USAGE		ELECTRICAL							
		Air / Water Temp Lbs. per 24 hours 70°/ 50°F    90°/ 70°F		Potable Gal. per 100 lbs. 90°/ 70°F	Condenser Gal. per 100 lbs. 90°/ 70°F	kWh Used per 100 lbs. 90°/ 70°F	Min. Circuit/ Max. Fuse Size	Amperage	Voltage	Circuit Wires (including ground)	Heat Rejection BTU/hr.	Refrigerant Charge Amount	Net / Ship Weight (lbs.)
Air-Cooled	DCM-500BAH-OS	618	450	12.0	N/A	5.62	20A	12.9A	115V/60/1	3	7,000	1 lb. 4.1 oz.	251 / 255
Water-Cooled	DCM-500BWH-OS	590	512	12.0	112	4.48	20A	12.6A	115V/60/1	3	6,000	11.5 oz.	245 / 255

### Cubelet Dimensions\*

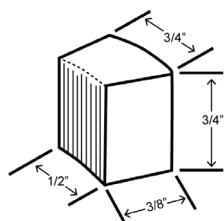

\* approximate size in inches, image not to scale

### Operating Limits

- Ambient Temp Range 45 - 100°F
- Water Temp Range 45 - 90°F
- Water Pressure 10 - 113 PSIG
- Voltage Range 104 - 127V
- If GFCI is required, a GFCI breaker MUST be used in lieu of GFCI receptacle

### Service

- Allow 6" (15 cm) clearance at rear and sides for proper air circulation and ease of maintenance/service should they be required. Allow 24" (61 cm) clearance at top to allow for removal of the auger.

*Not intended for outdoor use - avoid placement in direct sunlight.*

### Plumbing

- Icemaker Water Supply Line: Min. 1/4" Nominal ID Copper Water Tubing or Equivalent
- Icemaker Drain Line: Min. 3/4" Nominal ID Hard Pipe or Equivalent Water-Cooled Model (Lines Must Be Independent of Icemaker)
- Condenser Water Supply Line: Min. 1/4" Nominal ID Copper Water Tubing or Equivalent
- Condenser Drain/Return Line: Min. 1/4" Nominal ID Hard Pipe (open drain system) or Copper Water Tubing (closed loop system) or Equivalent

### Water Filter

*Please refer to water filter specification sheet for recommendations.*

*Hoshizaki reserves the right to change specifications without notice.*



# DCM-500B\_H-OS

## OPTI-SERVE SERIES SANITARY CUBELET ICE MACHINE/DISPENSER



DCM-500B\_H-OS  
07/02/24  
Item # 13147

FRONT VIEW

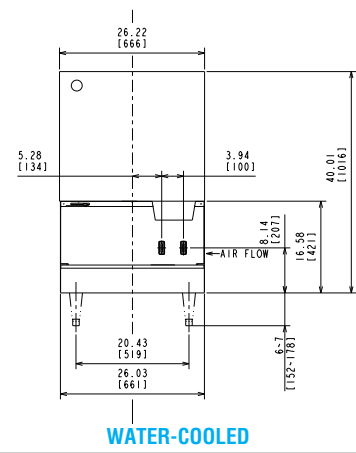
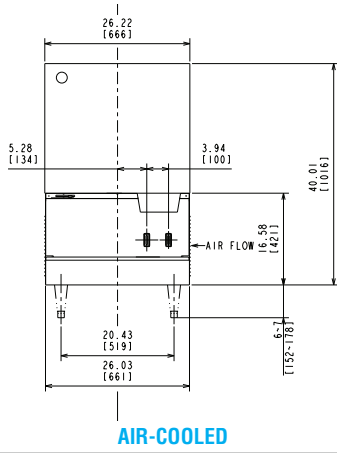

inch  
[mm]

SIDE VIEW

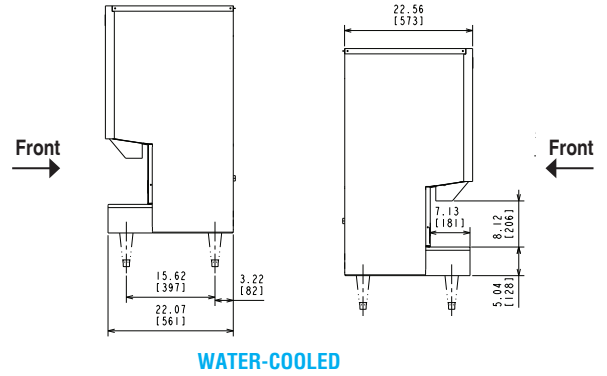
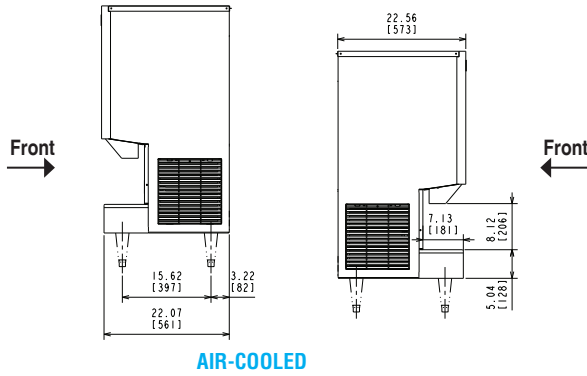

REAR VIEW

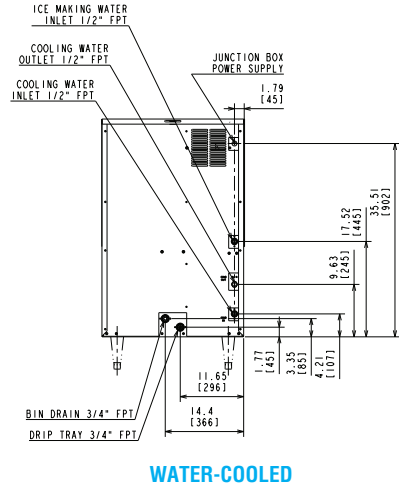
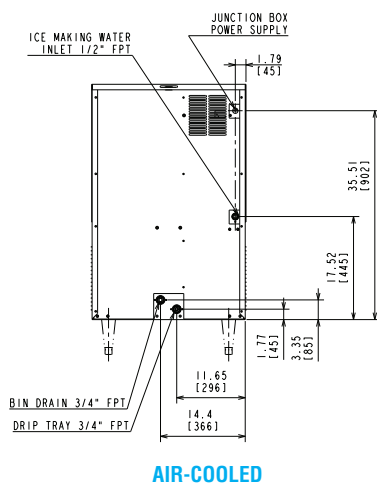

TOP VIEW

