

Whirlpool

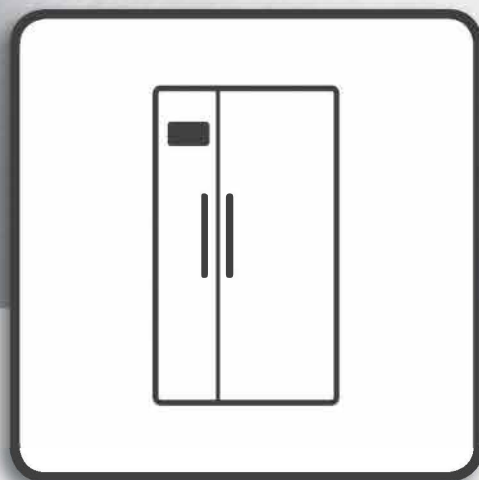

Health & Safety, Use & Care, Installation Guide
產品安全指引、使用說明、安裝指南

Model 產品型號:8WRS22SNHW



www.whirlpool.com.tw

INSTALLATION INSTRUCTIONS AND OWNER'S MANUAL

Side by Side Refrigerator 8WRS22SNH*

Do Not Throw Away - Additional important safety information included.

安裝指示和使用手冊 對開式冰箱 8WRS22SNH*

請勿丟棄 - 內含其他重要安全資訊。

TABLE OF CONTENTS / 目錄

REFRIGERATOR SAFETY	3	冰箱安全事項	20
INSTALLATION INSTRUCTIONS	4	安裝說明	21
Unpack the Refrigerator.....	4	拆封冰箱的包裝.....	21
Door Removal, Leveling, and Alignment	5	拆除冰箱門、水平調整與對齊.....	22
Handle Installation and Removal	7	把手安裝與拆卸.....	24
Location Requirements.....	8	位置要求.....	25
Electrical Requirements	8	電氣需求.....	25
Water Supply Requirements	8	供水要求.....	25
Connect Water Supply.....	9	連接供水.....	26
OPERATING YOUR REFRIGERATOR	11	操作冰箱	28
Using the Controls	11	使用控制項.....	28
Crisper Humidity Control (on some models)	12	保鮮濕度控制 (在某些機型上).....	28
REFRIGERATOR CARE	12	冰箱保養	28
Cleaning	12	清潔.....	28
Lights.....	12	燈光.....	30
Vacation and Moving Care.....	13	假期和搬家保養.....	30
Freezer Shelf (number of shelves varies by model)	13	冷凍架 (架子數量因機型而異).....	30
TROUBLESHOOTING	14	疑難排解	31
PERFORMANCE DATA SHEET	19	效能資料表	35
NOTES	36		

REFRIGERATOR SAFETY

Your safety and the safety of others are very important.

We have provided many important safety messages in this manual and on your appliance. Always read and obey all safety messages.



This is the safety alert symbol.

This symbol alerts you to potential hazards that can kill or hurt you and others.

All safety messages will follow the safety alert symbol and either the word “DANGER” or “WARNING.”

These words mean:

 **DANGER**

You can be killed or seriously injured if you don't immediately follow instructions.

 **WARNING**

You can be killed or seriously injured if you don't follow instructions.

All safety messages will tell you what the potential hazard is, tell you how to reduce the chance of injury, and tell you what can happen if the instructions are not followed.

IMPORTANT SAFETY INSTRUCTIONS

WARNING: To reduce the risk of fire, electric shock or injury to persons when using the refrigerator, follow basic precautions, including the following:

- Children should be supervised to ensure that they do not play with the appliance.
- This appliance is not intended for use by persons (including children) with reduced physical, sensory, or mental capabilities, or lack of experience and knowledge, unless they have been given supervision or instruction concerning use of the appliance by a person responsible for their safety.
- Do not use an extension cord.
- If power supply cord is damaged, it must be replaced by the manufacturer, its service agent, or a similarly qualified person in order to avoid a hazard.
- Connect to potable water supply only.
- This appliance is intended to be used in household and similar applications such as: staff kitchen areas in shops, offices, and other working environments; farm houses and by clients in hotels, motels, and other residential-type environments; bed and breakfast-type environments; and catering and similar non-retail applications.
- Do not store explosive substances such as aerosol cans with a flammable propellant in this appliance.
- Do not use replacement parts that have not been recommended by the manufacturer (e.g., parts made at home using a 3D printer).
- Keep ventilation openings, in the appliance enclosure or in the built-in structure, clear of obstruction.
- Do not use mechanical devices or other means accelerator the defrosting process, other than those recommended by the manufacturer.
- Do not damage the refrigerant circuit.
- Do not use electrical appliances inside the food storage compartments of the appliance, unless they are of the type recommended by the manufacturer.
- Ice maker kit can be added to some models. See serial tag inside the food compartment of appliance for ice maker kit model information.
- A qualified service technician must install the water line and ice maker. See installation instructions supplied with ice maker kit for complete details.

PLEASE KEEP THESE INSTRUCTIONS

Proper Disposal of Your Old Refrigerator

WARNING: Risk of child entrapment. Before You Throw Away Your Old Refrigerator or Freezer:

- Take off the doors.
- Leave the shelves in place so that children may not easily climb inside.

⚠ WARNING

Suffocation Hazard

Remove doors from your old refrigerator.

Failure to do so can result in death or brain damage.

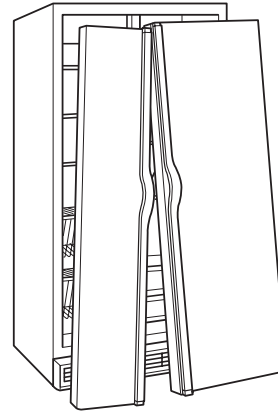

IMPORTANT: Child entrapment and suffocation are not problems of the past. Junked or abandoned refrigerators are still dangerous, even if they will sit for “just a few days.” If you are getting rid of your old refrigerator, please follow these instructions to help prevent accidents.

Important information to know about disposal of refrigerants:

Dispose of refrigerator in accordance with federal and local regulations. Refrigerants must be evacuated by a licensed, EPA-certified refrigerant technician in accordance with established procedures.

INSTALLATION INSTRUCTIONS

Unpack the Refrigerator

⚠ WARNING

Excessive Weight Hazard

Use two or more people to move and install refrigerator.

Failure to do so can result in back or other injury.

When Moving Your Refrigerator:

Your refrigerator is heavy. When moving the refrigerator for cleaning or service, be sure to cover the floor with cardboard or hardboard to avoid floor damage. Always pull the refrigerator straight out when moving it. Do not wiggle or “walk” the refrigerator when trying to move it, as floor damage could occur.

Remove packing materials. Do not use sharp instruments, rubbing alcohol, flammable fluids, or abrasive cleaners to remove tape or glue. These products can damage the surface of your refrigerator. For more information, see “Refrigerator Safety.”

Important information to know about glass shelves and covers:

Do not clean glass shelves or covers with warm water when they are cold. Shelves and covers may break if exposed to sudden temperature changes or impact, such as bumping. Tempered glass is designed to shatter into many small, pebble-size pieces. This is normal. Glass shelves and covers are heavy. Use both hands when removing them to avoid dropping.

Door Removal, Leveling, and Alignment

Gather the required tools and parts and read all instructions before starting installation. Save these instructions for future reference.

NOTE: Before moving your product into your home, measure the doorway of your home to see whether you need to remove the refrigerator and freezer doors. If door removal is necessary, see the instructions below.

IMPORTANT: Before you begin, unplug refrigerator or disconnect power. Remove food, the ice storage bin (on some models), and any adjustable door or utility bins from doors.

TOOLS NEEDED: Bubble level; flat-blade screwdriver; 5/16" and 11/16" wrench; 1/4", 3/8", and 5/16" hex-head socket wrenches, Phillips screwdriver tip #2 with 4" long as minimum, TORX[†] T30 screwdriver.



⚠ WARNING

Electrical Shock Hazard

Disconnect power before removing doors.

Failure to do so can result in death or electrical shock.

6 Top Left Hinge

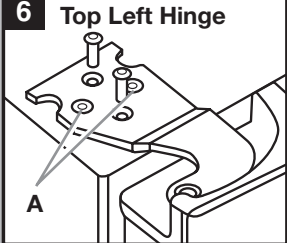

Do not remove A screws

5 Wiring

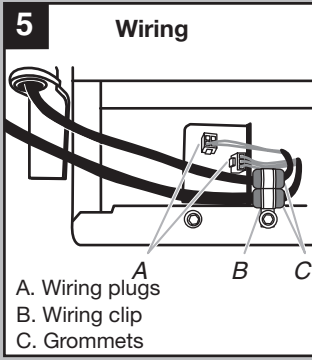

A. Wiring plugs
B. Wiring clip
C. Grommets

4 Water Dispenser Tubing

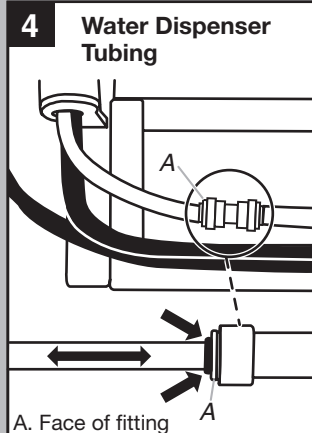

A. Face of fitting

3 Base Grille

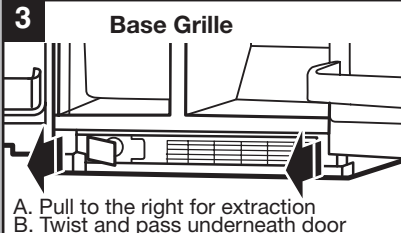

A. Pull to the right for extraction
B. Twist and pass underneath door

1 Full Refrigerator

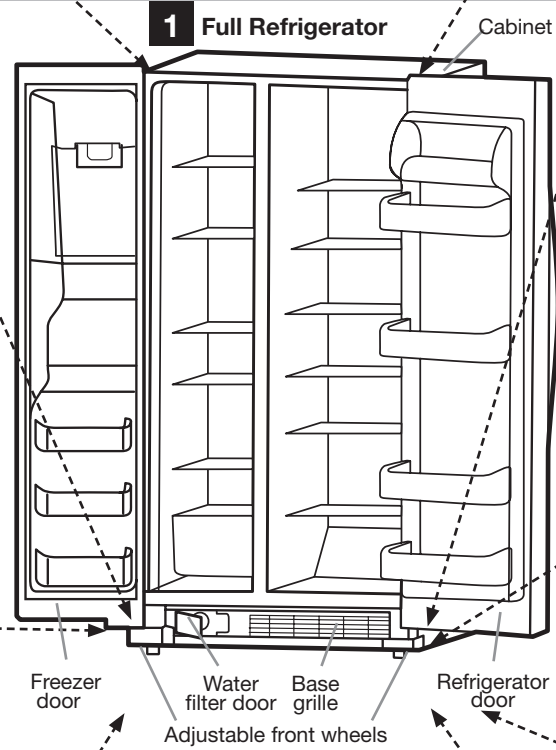

2 Water Filter Door and Base Grille

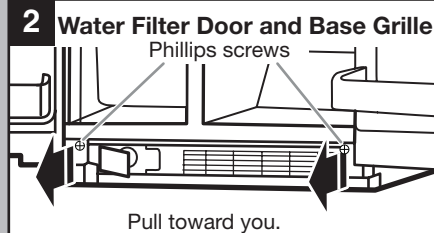

Phillips screws
Pull toward you.

7 Door Removal



8 Top Right Hinge



Do not remove A screws

9 Left and Right Bottom Hinge

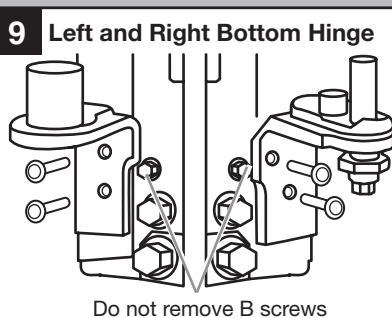

Do not remove B screws

10 Leveling screws

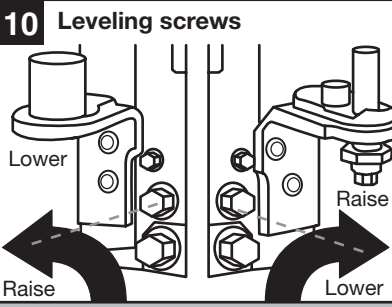

Lower
Raise
Raise
Lower

11 Locking Nut

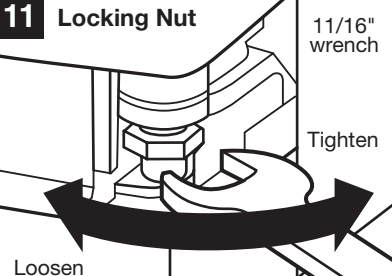

11/16" wrench
Tighten
Loosen

12 Alignment Screw

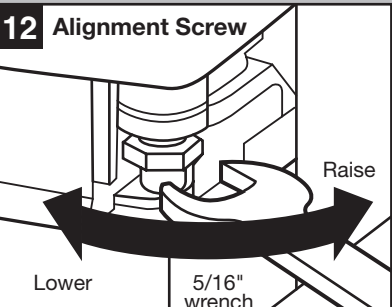

Lower
Raise
5/16" wrench

[†]TORX and T30 are trademarks of Acument Intellectual Properties, LLC.

Remove the Doors

If your refrigerator does not fit through the doorway or you are getting rid of your old refrigerator, follow the steps below for door removal.



1. Unplug refrigerator or disconnect power.
2. Fully open both doors. See graphic 1.
3. If your model has water dispensing, please open the water filter door by pulling it toward you. See graphic 2. It is not necessary to remove the water filter itself.
4. Pull the base grille toward you from the sides and then from the center until it dislodges. See graphic 2.
5. To remove the base grille, twist and pull the right side until this side passes underneath the refrigerator door. See graphic 3. Then pull the left side of the base grille for complete removal.
6. If your model has water dispensing in the door, disconnect the water dispenser tubing located below the freezer door.
 - Press the blue outer ring against the face of fitting and pull the dispenser tubing free. See graphic 4.

NOTE: Keep the water tubing connector attached to the tube that runs underneath the freezer. The door cannot be removed if the connector is still attached to the tube that runs through the door hinge.
7. If your model has water dispensing in the door, disconnect the wiring located below the freezer door. See graphic 5.
 - Remove the wiring clip and the bracket wire using a 1/4" hexagonal head socket wrench.
 - Disconnect the wiring plugs from the bracket wire.
8. Close the freezer door and use a TORX[†] T30 screwdriver to remove the top hinge completely. See graphic 6.

IMPORTANT: Do not remove either screw A. Hold the door while hinge is being removed.
9. Lift the freezer door straight up off from the bottom hinge. See graphic 7. The water dispenser tubing and wiring will remain attached to the freezer door.

NOTE: This may require two people, one to lift the door and another to feed the water tubing and wiring into the bottom hinge pin.

IMPORTANT: Rest the door on its side on a soft, clean surface, such as a towel, blanket, or piece of cardboard. This will help to avoid scratching or damaging the door, water tubing, and wiring.
10. Close the refrigerator door and use a TORX[†] T30 screwdriver to remove completely top hinge. See graphic 8.

IMPORTANT: Do not remove either screw A. Hold the door while hinge is being removed.
11. Lift the refrigerator door straight up off from the bottom hinge. See graphic 7.

IMPORTANT: Rest the door on its side on a soft, clean surface, such as a towel, blanket, or piece of cardboard. This will help to avoid scratching or damaging the door.

12. If your refrigerator without doors does not pass through the doorway, you may remove both bottom hinges. Use a 5/16" nut driver to remove these. See graphic 9.

IMPORTANT: Do not remove either screw B.

Replacing or Reinstalling Door and Hinges

If your doors and bottom hinges have been removed, please follow the next instructions for re-installation:

1. Reinstall both bottom hinges using a 5/16" nut driver to tighten screws. See graphic 9.
2. If your model has water dispensing in the door:
 - Lift the freezer door enough to feed the water dispenser tubing and wiring through the bottom hinge pin.

NOTE: This may require two people, one to lift the door and the other to feed the water tubing and wiring into the bottom hinge pin. See graphic 7.

 - Insert the freezer door into the bottom hinge pin.

IMPORTANT: Hold the door while hinge is being installed
3. Close the freezer door to align and reinstall the top hinge. Use a TORX[†] T30 screwdriver to tighten the screws. See graphic 8.

IMPORTANT: Provide additional support for the door while top hinge is being reinstalled. Do not depend on the door magnets to assure the door to the cabinet.
4. If your model has water dispensing in the door, connect the water dispenser tubing. For the connection, push the tubing into the dispenser tubing until black mark touches the face of fitting. See graphic 4.
5. Connect the wiring. See graphic 5.
6. Reinstall the wiring clip & the bracket wire using a 1/4" hexagonal head socket wrench.
7. Connect the wiring plugs from the bracket wire.
8. Lift the refrigerator door enough to insert the door into the bottom hinge pin. See graphic 7.

IMPORTANT: Hold the door while hinge is being installed.
9. Close the refrigerator door to align and reinstall the top hinge. Use a TORX[†] T30 screwdriver to tighten the screws. See graphic 6.

IMPORTANT: Provide additional support for the door while top hinge is being reinstalled. Do not depend on the door magnets to assure the door to the cabinet.

Leveling and Door Closing

Your refrigerator has two front adjustable wheels. See graphic 1. These are used to level the refrigerator under uneven floor conditions or want the doors to close more easily. Please follow the instructions below:

1. Use a Bubble level to check levelness of floor where the rear side of the refrigerator will rest. If the refrigerator is not leveled, adjust or add the shim on flooring to create a leveled floor for the rear side wheels. A leveled rear side prevents the refrigerator cabinet from forming a twist.
2. Place the refrigerator into its final location in the kitchen and open both doors.
3. Fully open both doors. See graphic 1.
4. If your model has water dispensing in the door, please open the water filter door by pulling it toward you. See graphic 2. It is not necessary to remove the water filter itself.
5. Pull the base grille toward you from the sides and then from the center until it dislodges. See graphic 2.
6. To remove the base grille, twist and pull the right side until this side passes underneath the refrigerator door. See graphic 3. Then pull the left side of the base grille for complete removal.

7. Raise the wheels while one person pushes on the refrigerator to lift from front side. Use the bubble level on top of the refrigerator or on its side to level the refrigerator. Check bubble level and at the same time observe the gaps and squareness to the adjacent cabinets, furniture or trim. If adjacent furnishings are not level, it may not be possible to achieve even gaps when product is level. Continue adjusting until all four corners are steady without rock.
8. Use a 3/8" nut driver to turn the leveling screws located in both sides of the refrigerator. See graphic 10. Depending on uneven floor conditions, you must turn one or both screws to the right or left several times to raise or lower the refrigerator.
9. Close both doors and check that they close as easily as you like. If not, turn both screws to the right to raise the refrigerator by tilting it more to the back until the doors close as easily as you like.
10. Check and make sure to the technician sheet is placed in the base grille cavity before assembling this into the cabinet.
11. Reinstall the base grille into the cabinet, introducing the left side first and then the right side of the base grille. See graphic 3. You may accommodate the water dispenser tubing and wiring into base grille cavity below the left bottom hinge.
12. Attach the base grille pushing into the cabinet clips. See graphic 2.

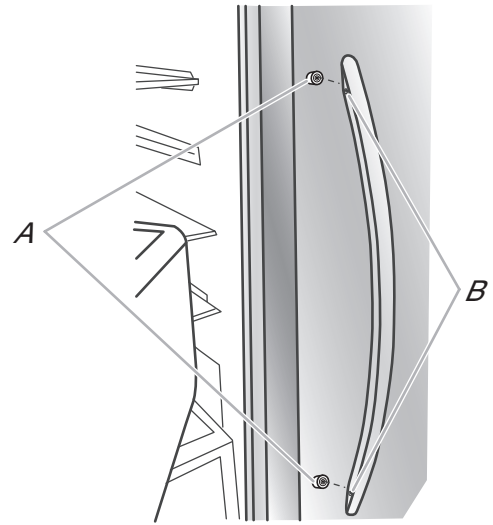

A. Shoulder screws
B. Setscrews inside the handle

Door Alignment

The refrigerator doors are designed to be slightly misaligned vertically when the refrigerator is empty. Please follow the next steps to align the refrigerator doors.

1. Use an 11/16" open-ended wrench tool to loosen the locking nut located below the refrigerator door. See graphic 11. Accommodate the wrench tool so that it fits in the space.
2. Use a 5/16" open-ended wrench tool to turn the alignment screw. See picture 12. Depending on how the refrigerator door is misaligned in relation to the freezer door, you must turn the screw to the right to raise or to the left to lower the refrigerator door until both doors have been aligned vertically.
3. Tighten the 11/16" locking nut with the wrench tool.
4. Attach the base grille if it was dislodged.

3. Firmly push the handle toward the door until the handle base is flush against the door.
4. While holding the handle, insert the short end of the hex key into the upper hole and slightly rotate the hex key until it is engaged in the setscrew.

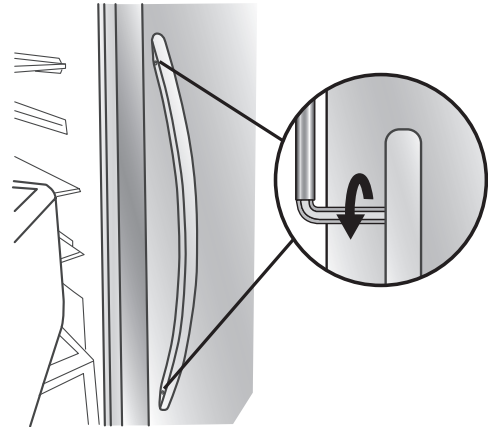

Handle Installation and Removal

PARTS INCLUDED: Door handles (2), 1/8" hex key, spare setscrew(s)

To Install the Handles:

NOTE: The handle mounting setscrews are preinstalled in the handle.

1. Remove the handles, which are packed inside the refrigerator.

NOTE: To avoid scratching the finish, place the handles on a towel or other soft surface.
2. Open the freezer door. On the refrigerator door, place the handle on the shoulder screws with the setscrews facing the freezer.

5. Using a clockwise motion, tighten the setscrew until it begins to contact the shoulder screw.
6. Repeat steps 4 and 5 to begin fastening the lower setscrew.
7. Once both setscrews have been partially tightened as outlined in the previous steps, fully tighten both the upper and lower setscrews.

IMPORTANT: When the screws feel tight, tighten them an additional quarter-turn. The handle is not properly installed without this extra tightening.

8. Open the refrigerator door and close the freezer door. Repeat steps 2 through 7 to install the other handle onto the freezer door with the setscrews facing the refrigerator.
9. Save the hex key and all instructions.

To Remove the Handles:

1. While holding the handle, insert the short end of the hex key into the lower setscrew hole and slightly rotate the hex key until it is engaged in the setscrew.
2. Using a counterclockwise motion, loosen the setscrew a quarter-turn at a time.
3. Repeat steps 1 and 2 for the upper setscrew. Gently pull the handle away from the door.
4. If necessary, use a Phillips screwdriver to remove the shoulder screws from the door.

Location Requirements

⚠ WARNING



Explosion Hazard
Keep flammable materials and vapors, such as gasoline, away from refrigerator.
Failure to do so can result in death, explosion, or fire.

IMPORTANT: This refrigerator is designed for indoor household use only.

To ensure proper ventilation for your refrigerator, allow for 1/2" (1.27 cm) of space on each side and at the top. Allow for 2" (5.08 cm) of space behind the refrigerator. If your refrigerator has an ice maker, allow extra space at the back for the water line connections. When installing your refrigerator next to a fixed wall, leave a 2" (5.08 cm) minimum space on each side (depending on your model) to allow the doors to swing open.

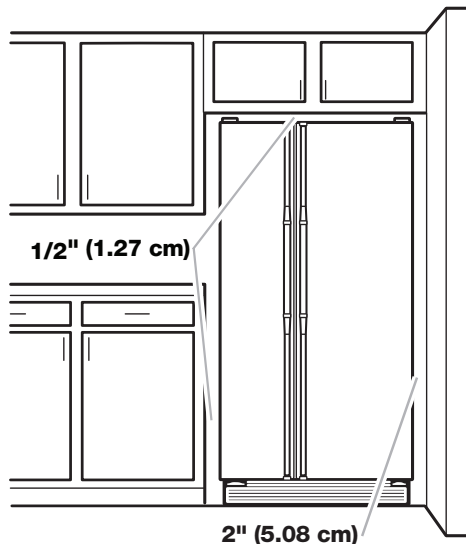

NOTES:

- This refrigerator is intended for use in a location where the temperature ranges from a minimum of 13°C (55°F) to a maximum of 43°C (110°F). The preferred room temperature range for optimum performance, which reduces electricity usage and provides superior cooling, is between 15°C (60°F) and 32°C (90°F). It is recommended that you do not install the refrigerator near a heat source, such as an oven or radiator.

- Normal minimum cabinet cut-out width required for product installation is 36" (91.44 cm). However, if the product is placed against an extended wall and the ability to remove the crisper pans is desired, an additional 18" (45.72 cm) of cabinet width is required, so a total cabinet opening width of 54" (137.16 cm) is recommended.

Electrical Requirements

⚠ WARNING



Electrical Shock Hazard
Plug into a grounded 3 prong outlet.
Do not remove ground prong.
Do not use an adapter.
Do not use an extension cord.
Failure to follow these instructions can result in death, fire, or electrical shock.

Before you move your refrigerator into its final location, it is important to make sure you have the proper electrical connection.

Recommended Grounding Method

A 115 V, 60 Hz, AC only, 15 A or 20 A fused, grounded electrical supply is required. It is recommended that a separate circuit serving only your refrigerator be provided. Use an outlet that cannot be turned off by a switch. Do not use an extension cord.

NOTE: Before performing any type of installation or cleaning, or removing a light bulb, disconnect the refrigerator from the electrical source. When you are finished, reconnect the refrigerator to the electrical source and reset the control (Thermostat, Refrigerator or Freezer Control depending on the model) to the desired setting. See the "Using the Controls" section in the User Instructions, User Guide, or Use and Care Guide.

Water Supply Requirements

Gather the required tools and parts before starting installation. Read and follow the instructions provided with any tools listed here.

TOOLS NEEDED:

- Flat-blade screwdriver
- 7/16" and 1/2" open-end or two adjustable wrenches
- 1/4" nut driver
- 1/4" drill bit
- Cordless drill

NOTE: Your refrigerator dealer has a kit available with a 1/4" (6.35 mm) saddle-type shutoff valve, a union, and copper tubing. Before purchasing, make sure a saddle-type valve complies with your local plumbing codes. Do not use a piercing-type or 3/16" (4.76 mm) saddle valve which reduces water flow and clogs more easily.

IMPORTANT:

- All installations must meet local plumbing code requirements.
- Use copper tubing and check for leaks. Install copper tubing only in areas where the household temperatures will remain above freezing.

Water Pressure

A cold water supply with water pressure of between 30 psi and 120 psi (207 kPa and 827 kPa) is required to operate the water dispenser and ice maker. If you have questions about your water pressure, call a licensed, qualified plumber.

- If your refrigerator has a water dispenser: After installation is complete, use the water dispenser to check the water pressure.
 - With the water filter removed, dispense 1 cup (237 mL) of water. If 1 cup of water is dispensed in 8 seconds or less, the water pressure to the refrigerator meets the minimum requirement.
 - If it takes longer than 8 seconds to dispense 1 cup of water, the water pressure to the refrigerator is lower than recommended. See "Problem Solver" for suggestions.

Reverse Osmosis Water Supply

IMPORTANT: The pressure of the water supply coming out of a reverse osmosis system going to the water inlet valve of the refrigerator needs to be between 30 psi and 120 psi (207 kPa and 827 kPa).

If a reverse osmosis water filtration system is connected to your cold water supply, the water pressure to the reverse osmosis system needs to be a minimum of 40 psi to 60 psi (276 kPa to 414 kPa).

If the water pressure to the reverse osmosis system is less than 40 psi to 60 psi (276 kPa to 414 kPa):

- Check to see whether the sediment filter in the reverse osmosis system is blocked. Replace the filter if necessary.
- Allow the storage tank on the reverse osmosis system to refill after heavy usage.
- If your refrigerator has a water filter, it may further reduce the water pressure when used in conjunction with a reverse osmosis system. Remove the water filter. See "Water Filtration System" in the User Instructions, User Guide, or Use & Care Guide.

If you have questions about your water pressure, call a licensed, qualified plumber.

Connect Water Supply

Read all directions before you begin.

IMPORTANT:

- Connect to potable water supply only.

Do not use with water that is microbiologically unsafe or of unknown quality without adequate disinfection before or after the system. Systems certified for cyst reduction may be used on disinfected waters that may contain filterable cysts.

- Plumbing shall be installed in accordance with the International Plumbing Code and any local codes and ordinances.

- The gray water tubing on the back of the refrigerator (which is used to connect to the household water line) is a plastic tube. Copper and plastic tubing connections from the household water line to the refrigerator are acceptable, and will help avoid off-taste or odor in your ice or water. Check for leaks.

If plastic tubing is used instead of copper, we recommend the following Whirlpool Part Numbers:

- W10505928RP (7 ft [2.14 m] jacketed plastic),
- 8212547RP (5 ft [1.52 m] plastic), or
- W10267701RP (25 ft [7.62 m] plastic).

- Install tubing only in areas where temperatures will remain above freezing.

TOOLS NEEDED:

Gather the required tools and parts before starting installation.

- Flat-blade screwdriver
- 7/16" and 1/2" open-end wrenches or two adjustable wrenches
- 1/4" nut driver

Connect to Water Line

IMPORTANT: If you turn the refrigerator on before the water line is connected, turn the ice maker OFF.

Style 1 (Recommended)

1. Unplug refrigerator or disconnect power.
2. Turn OFF main water supply. Turn ON nearest faucet long enough to clear line of water.
3. Use a quarter-turn shutoff valve or the equivalent, served by a 1/2" copper household supply line.

NOTE: To allow sufficient water flow to the refrigerator, a minimum 1/2" size copper household supply line is recommended.

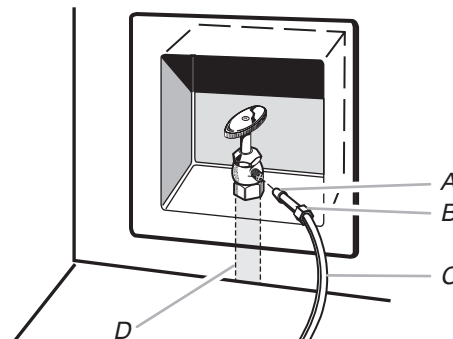

A. Bulb C. Copper tubing (to refrigerator)
 B. Nut D. Household supply line (1/2" minimum)

4. Now you are ready to connect the copper tubing to the shutoff valve. Use 1/2" (6.35 mm) OD soft copper tubing to connect the shutoff valve and the refrigerator.
 - Ensure that you have the proper length needed for the job. Be sure both ends of the copper tubing are cut square.
 - Slip compression sleeve and compression nut onto copper tubing as shown. Insert end of tubing into outlet end squarely as far as it will go. Screw compression nut onto outlet end with adjustable wrench. Do not overtighten.

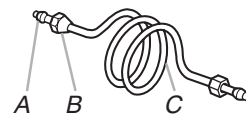

A. Compression sleeve C. Copper tubing
 B. Compression nut

- Place the free end of the tubing into a container or sink, and turn on main water supply to flush out tubing until water is clear. Turn off shutoff valve on the water pipe.

NOTE: Always drain the water line before making the final connection to the inlet of the water valve to avoid possible water valve malfunction.

- Bend the copper tubing to meet the water line inlet, which is located on the back of the refrigerator cabinet as shown. Leave a coil of copper tubing to allow the refrigerator to be pulled out of the cabinet or away from the wall for service.

Style 2

- Unplug refrigerator or disconnect power.
- Turn OFF main water supply. Turn ON nearest faucet long enough to clear line of water.
- Locate a 1/2" (1.27 cm) to 1 1/4" (3.18 cm) vertical cold water pipe near the refrigerator.

IMPORTANT:

- Make sure it is a cold water pipe.
- Horizontal pipe will work, but drill on the top side of the pipe, not the bottom. This will help keep water away from the drill and normal sediment from collecting in the valve.

- Determine the length of copper tubing you need. Measure from the connection on the lower rear corner of refrigerator to the water pipe. Add 7 ft (2.1 m) to allow for cleaning. Use 1/4" (6.35 mm) O.D. (outside diameter) copper tubing. Be sure both ends of copper tubing are cut square.
- Using a cordless drill, drill a 1/4" (6.35 mm) hole in the cold water pipe you have selected.

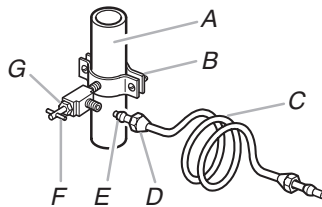

A. Cold water pipe
 B. Pipe clamp
 C. Copper tubing
 D. Compression nut
 E. Compression sleeve
 F. Shut-off valve
 G. Packing nut

- Fasten the shutoff valve to the cold water pipe with the pipe clamp. Be sure the outlet end is solidly in the 1/4" (6.35 mm) drilled hole in the water pipe and that the washer is under the pipe clamp. Tighten the packing nut. Tighten the pipe clamp screws slowly and evenly so the washer makes a watertight seal. Do not overtighten, or you may crush the copper tubing.
- Slip the compression sleeve and compression nut on the copper tubing as shown. Insert the end of the tubing into the outlet end squarely as far as it will go. Screw the compression nut onto outlet end with adjustable wrench. Do not overtighten.
- Place the free end of the tubing in a container or sink, and turn ON the main water supply. Flush the tubing until water is clear. Turn OFF the shutoff valve on the water pipe. Coil the copper tubing.

Connect to Refrigerator

Style 1

- Unplug refrigerator or disconnect power.
- Remove and discard the short, black plastic part from the end of the water line inlet.

- Thread the nut onto the end of the tubing. Tighten the nut by hand. Then tighten it with a wrench two more turns. Do not overtighten.

NOTE: To avoid rattling, be sure the copper tubing does not touch the cabinet's side wall or other parts inside the cabinet.

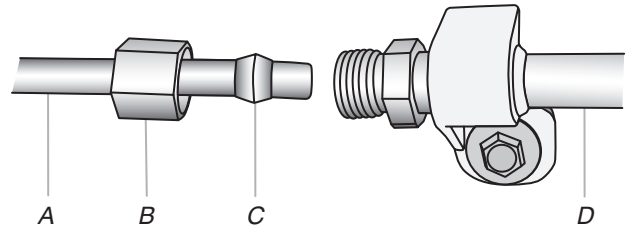

A. Household water line
 B. Nut (purchased)
 C. Ferrule (purchased)
 D. Refrigerator water tubing

- Install the water supply tube clamp around the water supply line to reduce strain on the coupling.
- Turn shutoff valve ON.
- Check for leaks. Tighten any connections (including connections at the valve) or nuts that leak.

Style 2

- Unplug refrigerator or disconnect power.
- Remove and discard the plastic part that is attached to the inlet of the water valve.
- Attach the copper tube to the valve inlet using a compression nut and sleeve as shown. Tighten the compression nut. Do not overtighten.
- Use the tube clamp on the back of the refrigerator to secure the tubing to the refrigerator as shown. This will help avoid damage to the tubing when the refrigerator is pushed back against the wall.
- Turn shutoff valve ON.
- Check for leaks. Tighten any connections (including connections at the valve) or nuts that leak.

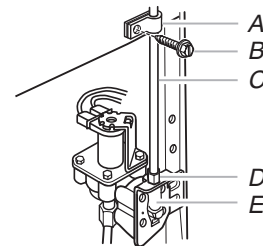

A. Tube clamp
 B. Tube clamp screw
 C. Copper tubing
 D. Compression nut
 E. Valve inlet

- On some models, the ice maker is equipped with a built-in water strainer. If your water conditions require a second water strainer, install it in the 1/4" (6.35 mm) water line at either tube connection. Obtain a water strainer from your nearest appliance dealer.

Style 3

- Unplug refrigerator or disconnect power.
- Remove and discard the black nylon plug from the gray water tube on the rear of the refrigerator.

- If the gray water tube supplied with the refrigerator is not long enough, a 1/4" x 1/4" (6.35 mm x 6.35 mm) coupling is needed in order to connect the water tubing to an existing household water line. Thread the provided nut onto the coupling on the end of the copper tubing.

NOTE: Tighten the nut by hand. Then tighten it with a wrench two more turns. Do not overtighten.

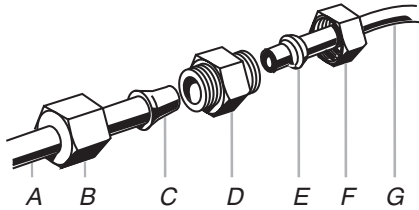

- | | |
|------------------------------|-------------------------|
| A. Refrigerator water tubing | E. Ferrule (purchased) |
| B. Nut (provided) | F. Nut (purchased) |
| C. Bulb | G. Household water line |
| D. Coupling (purchased) | |

- Turn shutoff valve ON.
- Check for leaks. Tighten any nuts or connections (including connections at the valve) that leak.

Complete the Installation

⚠ WARNING



Electrical Shock Hazard

- Plug into a grounded 3 prong outlet.
- Do not remove ground prong.
- Do not use an adapter.
- Do not use an extension cord.
- Failure to follow these instructions can result in death, fire, or electrical shock.

- Plug into a grounded 3 prong outlet.
- Flush the water system. See “Water and Ice Dispensers” in the User Instructions or User Guide.

NOTE: Allow 24 hours to produce the first batch of ice. Allow 72 hours to completely fill ice container.

OPERATING YOUR REFRIGERATOR

Using the Controls

For your convenience, your refrigerator controls are preset at the factory. When you first install your refrigerator, make sure that the controls are still preset. The Refrigerator Control and the Freezer Control should both be set to the “mid-settings.”

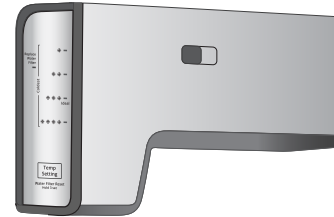

REFRIGERATOR

FREEZER

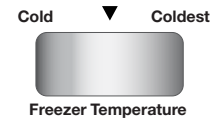
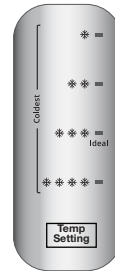

IMPORTANT:

- The Refrigerator Control adjusts the refrigerator compartment temperature. Every click on “Temp Setting” button makes refrigerator compartment colder (LED indicator on in 1 snowflake is Less Cold / LED indicator on in 2, 3 or 4 snowflake is colder / All LED indicator on is coldest), once you get to the last level the system will go back to the initial level.

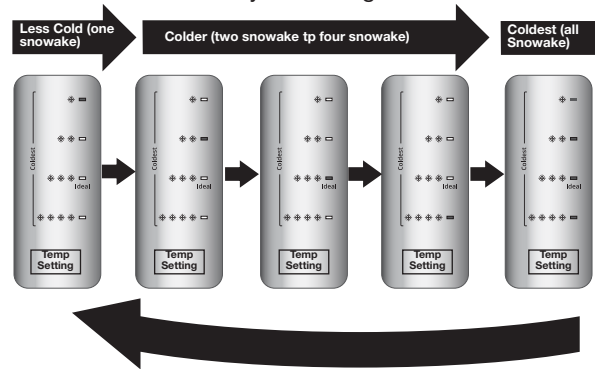

- The Freezer Control adjusts the freezer compartment temperature. Settings to the front of the mid-setting make the temperature less cold. Settings to the back of the mid-setting make the temperature colder.
- Wait 24 hours before you put food into the refrigerator. If you add food before the refrigerator has cooled completely, your food may spoil.

NOTE : Adjusting the Refrigerator and Freezer Controls to a higher (colder) than recommended setting will not cool the compartments any faster.

Adjusting Controls

Give the refrigerator time to cool down completely before adding food. It is best to wait 24 hours before you put food into the refrigerator. The settings indicated in the previous section should be correct for normal household refrigerator usage. The controls are set correctly when milk or juice is as cold as you like and when ice cream is firm.

If you need to adjust temperatures in the refrigerator or freezer, use the settings listed in the chart below as a guide. Wait at least 24 hours between adjustments.

CONDITION/REASON :	ADJUSTMENT :
REFRIGERATOR too warm	REFRIGERATOR Control one setting higher
FREEZER too warm / too little ice	FREEZER Control one setting higher
REFRIGERATOR too cold	REFRIGERATOR Control one setting lower
FREEZER too cold	FREEZER Control one setting lower

Crisper Humidity Control (on some models)

You can control the amount of humidity in the moisture-sealed crisper. Adjust the control to any setting between Low and High.

Low (open) for best storage of fruits and vegetables with skins.

High (closed) for best storage of fresh, leafy vegetables.

REFRIGERATOR CARE

Cleaning

⚠WARNING



Explosion Hazard

Risk of Fire or Explosion.

Flammable Refrigerant Used.

Do Not Use Mechanical Devices to Defrost Refrigerator.

Do Not Puncture Refrigerant Tubing.

Both the refrigerator and freezer sections defrost automatically. However, clean both sections about once a month to avoid buildup of odors. Wipe up spills immediately.

IMPORTANT: Because air circulates between both sections, any odors formed in one section will transfer to the other. You must thoroughly clean both sections to eliminate odors. To avoid odor transfer and drying out of food, wrap or cover foods tightly.

To Clean Your Refrigerator:

NOTE: Do not use abrasive or harsh cleaners such as window sprays, scouring cleansers, flammable fluids, cleaning waxes, concentrated detergents, bleaches or cleansers containing petroleum products on plastic parts, interior and door liners or gaskets. Do not use paper towels, scouring pads, or other harsh cleaning tools.

1. Unplug refrigerator or disconnect power.
2. Hand wash, rinse, and dry removable parts and interior surfaces thoroughly. Use a clean sponge or soft cloth and a mild detergent in warm water.
3. Wash stainless steel and painted metal exteriors with a clean sponge or soft cloth and a mild detergent in warm water.

⚠WARNING



Explosion Hazard

Risk of Fire or Explosion due to Puncture of Refrigerant Tubing;

Follow Handling Instructions Carefully.

Flammable Refrigerant Used.

4. There is no need for routine condenser cleaning in normal home operating environments. If the environment is particularly greasy or dusty, or there is significant pet traffic in the home, the condenser should be cleaned every 2 to 3 months to ensure maximum efficiency.

If you need to clean the condenser:

- Remove the base grille. See the “Door Removal” instructions, either in the User Instructions or the Installation Instructions and Owner’s Manual, or in the separate instruction sheet provided with your refrigerator.
- Use a vacuum cleaner with a soft brush to clean the grille, the open areas behind the grille and the front surface area of the condenser.
- Replace the base grille when finished.

5. Plug in refrigerator or reconnect power.

Lights

When the indoor light becomes damaged, please contact an authorized service agent to request replacement of the indoor light. Non-professional service personnel must not replace the indoor light.

Vacation and Moving Care

Vacations

If You Choose to Leave Refrigerator On While You Are Away:

1. Use up any perishables and freeze other items.
2. If your refrigerator has an automatic ice maker and is connected to the household water supply, turn off the water supply to the refrigerator. Property damage can occur if the water supply is not turned off.
3. If you have an automatic ice maker, turn off the ice maker.
NOTE: Depending on your model, raise the wire shutoff arm to OFF (up) position or press the switch to OFF (right).
4. Empty the ice bin.

If You Choose to Turn Refrigerator Off Before You Leave:

1. Remove all food from the refrigerator.
2. If your refrigerator has an automatic ice maker:
 - Turn off the water supply to the ice maker at least one day ahead of time.
 - When the last load of ice drops, raise the wire shutoff arm to the OFF (up) position or move the switch to the OFF (right) setting.
3. Unplug refrigerator.
4. Clean, wipe, and dry thoroughly.
5. Tape rubber or wood blocks to the tops of both doors to prop them open far enough for air to get in. This stops odor and mold from building up.

Moving

When you are moving your refrigerator to a new home, follow these steps to prepare it for the move.

1. If your refrigerator has an automatic ice maker:
 - Turn off the water supply to the ice maker at least one day ahead of time.
 - Disconnect the water line from the back of the refrigerator.
 - When the last load of ice drops, raise the wire shutoff arm to the OFF (up) position or move the switch to the OFF (right) setting.
2. Remove all food from the refrigerator and pack all frozen food in dry ice.
3. Empty the ice bin.
4. Unplug refrigerator.
5. Clean, wipe, and dry thoroughly.
6. Take out all removable parts, wrap them well, and tape them together so they don't shift and rattle during the move.
7. Depending on the model, raise the front of the refrigerator so it rolls more easily OR screw in the leveling legs so they don't scrape the floor. See "Adjust the Doors" or "Door Removal, Leveling and Alignment."
8. Tape the doors closed and tape the power cord to the back of the refrigerator.

When you get to your new home, put everything back and refer to the Installation Instructions for preparation instructions. Also, if your refrigerator has an automatic ice maker, remember to reconnect the water supply to the refrigerator.

Freezer Shelf

(number of shelves varies by model)

To Remove and Replace the Bottom Shelf:

1. Lift up the front and back of the shelf, and remove from the cabinet. Be sure not to remove the retaining rods.
2. Replace the shelf aligning the rods with the cabinet ribs. Apply a little pressure on the shelf to attach the rods to the ribs of the cabinet.

To Remove and Replace the Mid and Top Shelf:

1. With your hand, push the shelf from bottom to top until it is released from the holding rod. Pull the shelf until it is released from the rear rod. Remove from the cabinet.
2. To replace the shelf:
 - Replace rods into the support holes. Push the rods down so it clicks into the hole.
 - Identify the front and rear trim of the shelf.

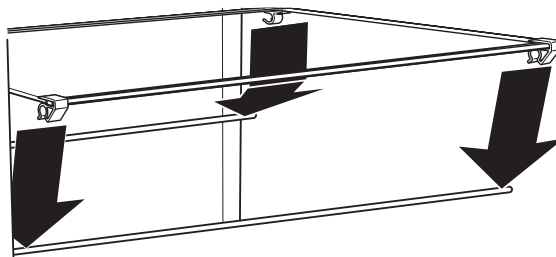

- Place the rear trim on the rear rod and push the shelf so it clicks the rod into the trim rear. (Keep the front raised while pushing).
- Lower the front of the shelf until the front trim is on the rod and push the shelf down so it clicks the rod into the trim rear.

NOTE: Be sure that both sides of the shelf are positioned evenly in the shelf support holes and the shelf is secure.

TROUBLESHOOTING

First try the solutions suggested here or visit our website to possibly avoid the cost of a service call.

⚠ WARNING



Electrical Shock Hazard

Plug into a grounded 3 prong outlet.

Do not remove ground prong.

Do not use an adapter.

Do not use an extension cord.

Failure to follow these instructions can result in death, fire, or electrical shock.

GENERAL OPERATION	Possible Causes and/or Recommended Solutions
Refrigerator will not operate	<ul style="list-style-type: none"> ■ Not connected to an electrical supply - Plug the power cord into a grounded 3 prong outlet. Do not use an extension cord. ■ No power to the electrical outlet - Plug in a lamp to see if the outlet is working. ■ Household fuse has blown or circuit breaker has tripped - Replace the fuse or reset the circuit breaker. If the problem continues, contact a licensed electrician. ■ New installation - Following installation, allow 24 hours for the refrigerator and freezer to cool completely. NOTE: Adjusting the temperature control(s) to the coldest setting will not cool either compartment (refrigerator or freezer) more quickly.
Motor seems to run too much	<ul style="list-style-type: none"> ■ Your new refrigerator has an energy-efficient motor - The refrigerator may run longer than you're used to, because the compressor and fans operate at lower speeds that are more energy-efficient. This is normal. NOTE: Your refrigerator may run even longer if the room is warm, a large load of food is added, the doors are opened often, or if a door has been left open.
Refrigerator seems noisy	<p>The compressor in your new refrigerator regulates temperature more efficiently and uses less energy than older models. During various stages of operation, you may hear normal operating sounds that are unfamiliar.</p> <p>The following noises are normal:</p> <ul style="list-style-type: none"> ■ Buzzing/Clicking - Heard when the water valve opens and closes to dispense water or fill the ice maker. If the refrigerator is connected to a water line, this is normal. If the refrigerator is not connected to a water line, turn off the ice maker. ■ Cracking/Crashing - Heard when ice is ejected from the ice maker mold. ■ Popping - Heard when the inside walls contract/expand, especially during initial cooldown. ■ Pulsating/Whirring - Heard when the fans/compressor adjust to optimize performance during normal operation. ■ Rattling - Heard when water passes through the water line, or due to the flow of refrigerant. Rattling may also come from items placed on top of the refrigerator. ■ Water running or gurgling - Heard when ice melts during the defrost cycle and water runs into the drain pan. ■ Sizzling - Heard when water drips onto the heater during the defrost cycle.

GENERAL OPERATION	Possible Causes and/or Recommended Solutions
Temperature is too warm	<ul style="list-style-type: none"> ■ New installation - Following installation, allow 24 hours for the refrigerator and freezer to cool completely. NOTE: Adjusting the temperature control(s) to the coldest setting will not cool either compartment (refrigerator or freezer) more quickly. ■ Doors are opened often or not closed completely - This allows warm air to enter the refrigerator. Minimize door openings, keep the doors fully closed, and make sure both doors are properly sealed. ■ Air vents are blocked - Remove items that are immediately in front of the vents. ■ Large amount of warm food recently added - Allow several hours for the refrigerator to return to its normal temperature. ■ Controls are not set correctly for the surrounding conditions - Adjust the controls to a colder setting. Check the temperature again in 24 hours.
Temperature is too cold	<ul style="list-style-type: none"> ■ Controls are not set correctly for the surrounding conditions - Adjust the controls to a warmer setting. Check the temperature again in 24 hours. ■ Top refrigerator shelf is colder than lower shelves - On some models, air from the freezer enters the refrigerator compartment through vents near the top refrigerator shelf. As a result, the top shelf can be slightly colder than lower shelves. ■ Air vents are blocked - Remove items that are immediately in front of the vents.
Interior moisture buildup	<p>NOTE: Some moisture buildup is normal. Clean with a soft dry cloth.</p> <ul style="list-style-type: none"> ■ Room is humid - A humid environment contributes to moisture buildup. Use the refrigerator only in an indoor location, with as little humidity as possible. ■ Doors are opened often or not closed completely - This allows humid air to enter the refrigerator. Minimize door openings, keep the doors fully closed, and make sure both doors are properly sealed.
Interior lights do not work	<ul style="list-style-type: none"> ■ Doors have been open for an extended period of time - Close the doors to reset the lights. ■ Light bulb is loose in the socket or has burned out - On models with incandescent interior light bulbs, tighten or replace the bulb. See the “Lights” section. <p>NOTE: On models with mini LED lights, call for assistance or service if the interior lights do not illuminate when either door is opened. See the Warranty in the User Instructions or User Guide for contact information.</p>
Dispenser lights do not work (on some models)	<ul style="list-style-type: none"> ■ Dispenser light is turned off - On some models, if the dispenser light is set to OFF, the light will turn on only when a dispenser pad/lever is pressed. If you want the dispenser light to stay on continuously, select a different setting. See “Water and Ice Dispensers” in the User Instructions or User Guide. ■ Dispenser light is set to AUTO or NIGHT LIGHT - On some models, if the dispenser light is set to AUTO or NIGHT LIGHT, make sure the dispenser light sensor is not blocked. See “Water and Ice Dispensers” in the User Instructions or User Guide. <p>NOTE: On models with mini LED lights, call for assistance or service if the dispenser lights do not operate correctly. See the Warranty in the User Instructions or User Guide for contact information.</p>

⚠ WARNING



Explosion Hazard

Use nonflammable cleaner.
Failure to do so can result in death, explosion, or fire.

DOORS AND LEVELING	Possible Causes and/or Recommended Solutions
Doors are difficult to open	<ul style="list-style-type: none"> ■ Gaskets are dirty or sticky - Clean the gaskets and contact surfaces with mild soap and warm water. Rinse and dry with a soft cloth.
Doors will not close completely	<ul style="list-style-type: none"> ■ Door is blocked open - Move food packages away from the door. Make sure all bins and shelves are in their correct positions. Make sure all packaging materials have been removed.
Doors appear to be uneven	<ul style="list-style-type: none"> ■ Doors need to be aligned, or refrigerator needs to be leveled - See the leveling and door alignment instructions.
Refrigerator rocks and is not stable	<ul style="list-style-type: none"> ■ Refrigerator is not level - To stabilize the refrigerator, remove the base grille and lower the leveling feet until they touch the floor. See the leveling and door alignment instructions.

⚠ WARNING



Cut Hazard

Use a sturdy glass when dispensing ice.
Failure to do so can result in cuts.

ICE AND WATER	Possible Causes and/or Recommended Solutions
Ice maker is not producing ice, not producing enough ice, or producing small/hollow ice	<ul style="list-style-type: none"> ■ Refrigerator is not connected to a water supply, or the water supply shutoff valve is not fully turned on - Connect the refrigerator to a water supply and make sure the water shutoff valve is fully open. ■ Kink in the water source line - A kink in the water line can reduce water flow, resulting in decreased ice production, small ice cubes, and/or hollow or irregularly-shaped ice. Straighten the water line. ■ Ice maker is not turned on - Turn on the ice maker. See “Ice Maker and Storage Bin” in the User Instructions or User Guide. ■ New installation - After connecting the refrigerator to a water source, flush the water system. (See “Water and Ice Dispensers” in the User Instructions or User Guide.) Wait 24 hours for ice production to begin. Wait 72 hours for full ice production. Discard the first three batches of ice produced. ■ Large amount of ice was recently removed - Allow sufficient time for the ice maker to produce more ice. ■ Ice is jammed in the ice maker ejector arm (on some models) - Remove ice from the ejector arm using a plastic utensil. ■ Inadequate water pressure - Verify that the household has adequate water pressure. See “Water Supply Requirements.” ■ Water filter is installed incorrectly - Make sure the filter is properly installed. See “Water Filtration System” in the User Instructions or User Guide. ■ A reverse osmosis water filtration system is connected to your cold water supply - This can decrease water pressure. See “Water Supply Requirements.” <p>NOTE: If questions remain regarding water pressure, contact a licensed, qualified plumber.</p>

ICE AND WATER**Possible Causes and/or Recommended Solutions**

Ice dispenser will not operate properly

- **Doors not closed completely** - Make sure both doors are firmly closed. (On some models, only the freezer door must be closed in order to operate the dispenser.)
 - **New installation** - After connecting the refrigerator to a water source, flush the water system. (See “Water and Ice Dispensers” in the User Instructions or User Guide.) Wait 24 hours for ice production to begin. Wait 72 hours for full ice production. Discard the first three batches of ice produced.
 - **Ice maker is not turned on, or ice bin is not installed correctly** - Turn on the ice maker and make sure the ice storage bin is firmly in position. See “Ice Maker and Storage Bin” in the User Instructions or User Guide.
 - **Ice is clogged or frozen together in the ice storage bin, or ice is blocking the ice delivery chute** - Remove or separate the clogged ice, using a plastic utensil if necessary. Clean the ice delivery chute and the bottom of the ice storage bin using a warm damp cloth; then, dry both thoroughly. To avoid clogging and to maintain a fresh supply of ice, empty the storage bin and clean both the storage bin and the delivery chute every 2 weeks.
 - **Wrong ice has been added to the storage bin** - Use only ice cubes produced by the current ice maker.
 - **Dispenser is locked** - Unlock the dispenser. See “Water and Ice Dispensers” in the User Instructions or User Guide.
 - **Ice dispenser jams while dispensing crushed ice** - For models with the ice storage bin on the door, temporarily switch from crushed ice to cubed ice to clear the jam.
 - **Dispenser pad/lever has been pressed too long** - Ice will automatically stop dispensing. Wait a few minutes for the dispenser to reset, then resume dispensing. Take large amounts of ice directly from the ice bin, not through the dispenser.
 - **Water pressure to the home is not at or above 30 psi (207 kPa)** - The water pressure to the home affects the flow from the dispenser. See “Water Supply Requirements” section.
 - **Water filter is clogged or incorrectly installed** - Replace filter or reinstall it correctly. See “Water Filtration System” in the User Instructions or User Guide.
-

Ice or water has an off-taste, odor, or gray color

- **New plumbing connections** - New plumbing connections can result in off-flavored or discolored ice or water. This problem should go away over time.
 - **Ice has been stored too long** - Discard the ice and wash the ice bin. Allow 24 hours for the ice maker to produce new ice.
 - **Odor has transferred from food** - Use airtight moisture-proof packaging to store food.
 - **Use of non-recommended water supply line** - Odors and tastes can transfer from certain materials used in non-recommended water supply lines. Use only a recommended water supply line. See “Water Supply Requirements” section.
 - **There are minerals (such as sulfur) in the water** - A water filter may need to be installed in order to remove the minerals.
 - **Water filter was recently installed or replaced** - Gray or dark discoloration in ice or water indicates that the water filtration system needs additional flushing. See “Water and Ice Dispensers” in the User Instructions or User Guide.
-

Water dispenser will not operate properly

- **Doors not closed completely** - Make sure both doors are firmly closed. (On some models, only the freezer door must be closed in order to operate the dispenser.)
- **Refrigerator is not connected to a water supply, or the water supply shutoff valve is not turned on** - Connect the refrigerator to a water supply and make sure the water shutoff valve is fully open.
- **Kink in the water source line** - A kink in the water line can reduce water flow to the dispenser. Straighten the water line.
- **Water pressure to the home is not at or above 30 psi (207 kPa)** - The water pressure to the home affects the flow from the dispenser. See “Water Supply Requirements” section.
- **New installation** - After connecting the refrigerator to a water source, flush the water system. See “Water and Ice Dispensers” in the User Instructions or User Guide.
- **Dispenser is locked** - Unlock the dispenser. See “Water and Ice Dispensers” in the User Instructions or User Guide.
- **Water filter is clogged or incorrectly installed** - Replace filter or reinstall it correctly. See “Water Filtration System” in the User Instructions or User Guide.
- **A reverse osmosis water filtration system is connected to your cold water supply** - This can decrease water pressure. See “Water Supply Requirements” section.

NOTE: If questions remain regarding water pressure, contact a licensed, qualified plumber.

ICE AND WATER**Possible Causes and/or Recommended Solutions**

Water is leaking or dripping from the dispenser

NOTE: After dispensing, a few additional drops of water are normal.

- **Glass was not held under the dispenser long enough** - Hold the glass under the dispenser for 2 to 3 seconds after releasing the dispenser pad/lever.
- **New installation, or water filter was recently installed or replaced** - Air in the water lines causes the water dispenser to drip. Flush the water system to remove the air in the water lines. See “Water and Ice Dispensers” in the User Instructions or User Guide.
- **Residual ice in the dispenser chute is melting** - Make sure the ice chute is free of ice shavings or pieces.

Water is leaking from the back of the refrigerator

- **Water line connections are not fully tightened** - Make sure all connections are firmly tightened. See “Connect Water Supply” section.

Water from the dispenser is not cool enough (on some models)

NOTE: Water from the dispenser is chilled to 50°F (10°C).

- **New installation** - Allow 24 hours after installation for the water supply to cool completely.
 - **Recently dispensed a large amount of water** - Allow 24 hours for the new water supply to cool completely.
 - **Water has not been recently dispensed** - The first glass of water may not be cool. Discard the first glass of water dispensed.
 - **Refrigerator is not connected to a cold water pipe** - Make sure the refrigerator is connected to a cold water pipe. See “Water Supply Requirements” section.
-

PERFORMANCE DATA SHEET

Water Filtration System

Model P5WB2L/P4RFB Capacity 200 Gallons (757 Liters)



System tested and certified by NSF International against NSF/ANSI Standard 42 for the reduction of Chlorine Taste and Odor, and Particulate Class I*; and against NSF/ANSI Standard 53 for the reduction of Live Cysts, Asbestos, Lead, Lindane, Toxaphene, Atrazine, and 2,4 - D.

This system has been tested according to NSF/ANSI Standards 42 and 53 for the reduction of the substances listed below. The concentration of the indicated substances in water entering the system was reduced to a concentration less than or equal to the permissible limit for water leaving the system, as specified in NSF/ANSI Standards 42 and 53.

Substance Reduction	NSF Reduction Requirements	Average Influent	Influent Challenge Concentration	Maximum Effluent	Minimum % Reduction	Average % Reduction
Aesthetic Effects						
Chlorine Taste/Odor	50% reduction	2.0 mg/L	2.0 mg/L ± 10%	0.20 mg/L	97	97.2
Particulate Class I*	85% reduction	7,300,000 #/mL	At least 10,000 particles/mL	75,000 #/mL**	99	99.4
Contaminant Reduction	NSF Reduction Requirements	Average Influent	Influent Challenge Concentration	Maximum Effluent	Minimum % Reduction	Average % Reduction
Live Cysts†	99.95%	160,000/L	50,000/L minimum	54/L†	99.97	99.99
Asbestos	99%	87 MFL	10 ⁷ to 10 ⁸ fibers/L††	0.17 MFL	99	99
Lead: @ pH 6.5	0.010 mg/L	0.160 mg/L	0.15 mg/L ± 10%	0.001 mg/L	99.4	99.4
Lead: @ pH 8.5	0.010 mg/L	0.140 mg/L	0.15 mg/L ± 10%	0.005 mg/L	98.6	98.6
Lindane	0.0002 mg/L	0.0019 mg/L	0.002 mg/L ± 10%	0.00002 mg/L	98.9	99
Toxaphene	0.003 mg/L	0.014 mg/L	0.015 mg/L ± 10%	0.001 mg/L	93	93
Atrazine	0.003 mg/L	0.0094 mg/L	0.009 mg/L ± 10%	0.0005 mg/L	94.5	94.7
2,4 - D	0.07 mg/L	0.220 mg/L	0.210 mg/L ± 10%	0.028 mg/L	87.5	96.1

Test Parameters: pH = 7.5 ± 0.5 unless otherwise noted. Flow = 0.5 gpm (1.9 Lpm). Pressure = 60 psig (413.7 kPa). Temperature = 68°F to 71.6°F (20°C to 22°C). Rated service capacity = 200 gallons (757 liters).

- It is important that operational, maintenance, and filter replacement requirements be carried out for the product to perform as advertised. Property damage can occur if all instructions are not followed.
- Use replacement filter according you filtration system, see “Ice and Water” in the User Guide.
- Water Filter:
Water Filtration System Style 1 - Order Part # EDR1RXD1
Water Filtration System Style 2 - Order Part # EDR2RXD1
When the water filter status changes from TURN OFF to RED light on your control panel, it is recommended that you replace the filter.
- After changing the water filter, flush the water system. See “Water and Ice Dispensers” or “Water Dispenser” in the User Instructions or User Guide.
- These contaminants are not necessarily in your water supply. While testing was performed under standard laboratory conditions, actual performance may vary.
- The product is for cold water use only.
- The water system must be installed in compliance with state and local laws and regulations.
- Do not use with water that is microbiologically unsafe or of unknown quality without adequate disinfection before or after the system. Systems certified for cyst reduction may be used on disinfected waters that may contain filterable cysts.
- Refer to the “Warranty” section (in the User Instructions or User Guide) for the Manufacturer’s name, address and telephone number.
- Refer to the “Warranty” section (in the User Instructions or User Guide) for the Manufacturer’s limited warranty.

Application Guidelines/Water Supply Parameters

Water Supply	City or Well
Water Pressure	30 psi - 120 psi (207 kPa - 827 kPa)
Water Temperature	33°F - 100°F (0.6°C - 37.8°C)
Service Flow Rate	0.5 gpm (1.9 Lpm) @ 60 psi

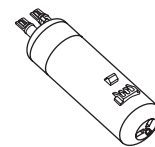

*Class I particle size: >0.5 to <1 um

**Test requirement is at least 100,000 particles/mL of AC Fine Test Dust.

†Based on the use of Cryptosporidium parvum oocysts

††Fibers greater than 10 um in length

NSF is a registered trademark of NSF International.

冰箱安全事項

您與他人的安全都不容忽視。

本公司已在這份手冊與電器上提供許多重要的安全提示資訊，請務必一一閱讀並遵守。



這是安全警告符號。

此符號表示存在可能導致您或他人傷亡的潛在危險。

所有安全提醒的前方都有安全提示符號以及「危險」或「警告」字樣。這些字詞指的是：

 **危險**

若不立即遵守指示，則有死亡或受重傷之虞。

 **警告：**

若不遵照指示，您可能會面臨死亡或重傷危險。

所有安全提示信息都會告訴您有哪些潛在危險、如何降低受傷機率，以及不遵守指示會有哪些後果。

重要安全說明

警告： 在使用冰箱時，為降低火災、觸電或人員傷亡風險，請遵守基本的謹慎原則，包括：

- 兒童需有成人看护，以確保其不會將本電器當做玩具。
- 身體行動不便、感官或智力障礙或缺乏相關經驗和知識者（包括兒童），除非受到其安全負責人的監督或關於如何安全使用本電器的指導，否則不得使用本電器。
- 請勿使用加長電源線。
- 如果電源線受損，則必須由製造商、其服務代理或類似合格人士加以替換，避免危險。
- 請僅連接至飲用水水源。
- 本電器旨在用於家居及類似應用場合：比如，商店、辦公室其他工作環境中的員工廚房區域；農舍以及供客戶用於酒店旅館和其他住宅型環境；床上和早餐類環境；餐飲及類似非售應用場合。
- 請勿將爆炸性物質存放於本電器中，比如，裝有易燃推進劑氣溶膠罐。
- 請勿使用製造商未推薦的替換部件（例如，使用 3D 打印在家製作的部件）。
- 使電器外殼或內置結構中的開口保持通風，未堵塞。
- 請勿使用非製造商推薦的機械設備或其他裝置加快除霜程。
- 請勿損害制冷劑回路。
- 請勿在本電器的食物儲存腔內使用電器，除非其為製造推薦的類型。
- 可向一些型號添加製冰機套件。請參見本電器食物儲存內的系列標籤了解有關製冰機套件型號的信息。
- 必須由合格的維修技術人員安裝水管和製冰機。請參見製冰機套件隨附的安裝說明了解完整詳情。

請遵守這些指示

請妥善棄置不用的舊冰箱

警告： 孩童可能有被困住的危險。丟棄舊冰箱或舊冰櫃之前：

- 拆下所有冰箱門。
- 將冰箱架保留在原處，才不至於讓孩童毫不費力地爬進冰箱內。



警告

窒息危險

取下老舊冰箱的門

未拔下插頭可能導致人員死亡或腦部受傷。

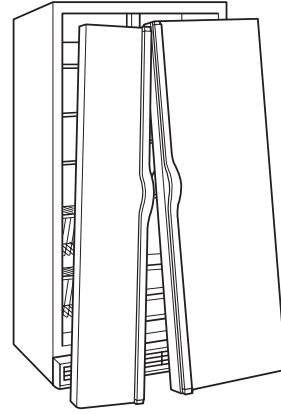

重要事項： 孩童誤入冰箱而窒息的意外事件時有所聞。報廢或棄置不用的冰箱仍然會有危險，即使只是放在某處「幾天而已」。

如果您要丟棄舊冰箱，請依照這些指示以免發生意外。

有關棄置冷媒的重要資訊：

請依照美國聯邦與當地的廢棄物處理規範棄置冷媒。冷媒必須由持有執照、通過EPA 認證的冷媒技師遵循既定程序予以排空。

安裝說明

拆封冰箱的包裝

移除包裝材料。請勿使用銳利的器具、除污劑、可燃性液體或腐蝕性清潔劑來清除膠帶或黏膠。此類產品會損壞冰箱表面。如須更多資訊，請參閱「冰箱安全事項」。



警告

超重危險

搬動和安裝冰箱需要兩人或以上。

否則可能導致人員後背或其他部位受傷。

移動冰箱時：

您的冰箱很重。移動冰箱供清潔或維修時，確定用紙板或硬板蓋住地板，避免毀損地面。經常以直拉的方式移動冰箱。嘗試移動冰箱時，不得擺動或「推動」冰箱，以免毀損地面。

有關玻璃架和玻璃蓋的重要資訊：

玻璃架和蓋子冷凍時，不得以溫水清洗。若遇突然溫度變更或碰撞之類的外力，玻璃架和蓋子可能會破裂。強化玻璃的設計就是在碎裂時形成許多鵝卵石大小的碎片。這是正常情況。玻璃架和蓋子很重。所以請用兩手取出，以免墜落。

拆除冰箱門、水平調整與對齊

開始安裝前，請先取得必要的工具與零件並詳閱所有指示。請保存這些指示以供未來參考之用。

備註：在您將產品移至住家前，請先測量住家出入口的寬度以判斷是否需要事先拆卸冰箱門和冷凍室的門。如果必須拆卸冰箱門，請參閱以下指示。

重要事項：在您開始前，請先拔除冰箱電源或中斷電源。取出食物、儲冰盒（某些機型上）與任何調整式冰箱門或冰箱門上的置物盒。

所需工具：氣泡水平儀；一字螺絲起子；5/16" 和 11/16" 扳手；1/4"、3/8" 和 5/16" 六角頭套筒扳手、尖端為 #2 的十字螺絲起子且長度至少為 4"、TORX® T30 螺絲起子。



警告

觸電危險

取下門前中斷所有電源連接。
未拔下插頭可能導致人員傷亡或觸電。

6 左上轉軸

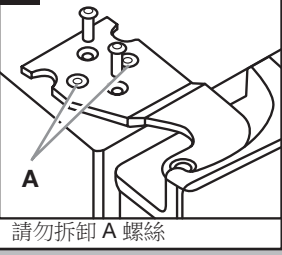

請勿拆卸 A 螺絲

5 配線

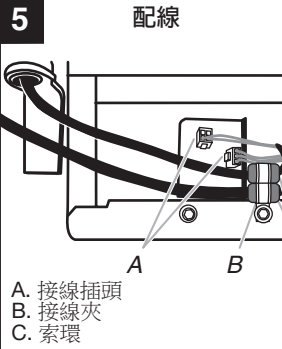

A. 接線插頭
B. 接線夾
C. 索環

4 飲水機管線

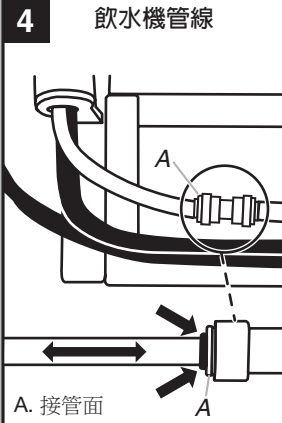

A. 接管面

3 底座格柵

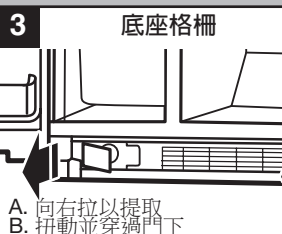

A. 向右拉以提取
B. 扭動並穿過門下

1 完整冰箱

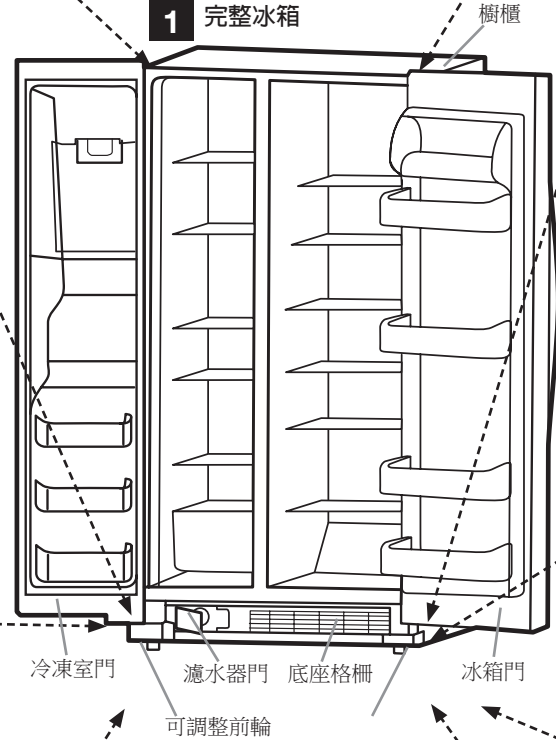

7 冰箱門拆卸



8 右上轉軸

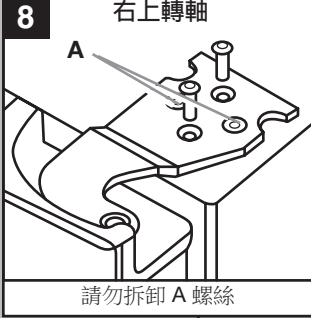

請勿拆卸 A 螺絲

9 左下和右下轉軸

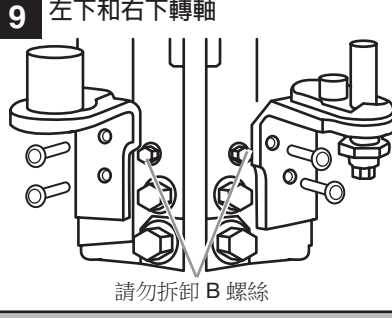

請勿拆卸 B 螺絲

10 水平調整螺絲

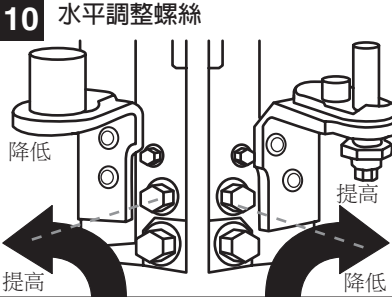

降低 (Decrease)
提高 (Increase)

11 鎖定螺帽

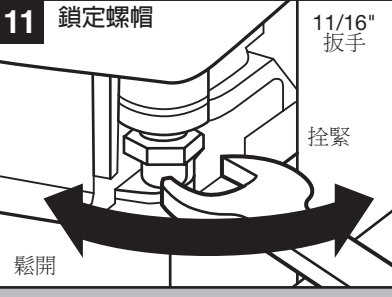

11/16" 扳手
控緊 (Tighten)
鬆開 (Loosen)

12 調整螺絲

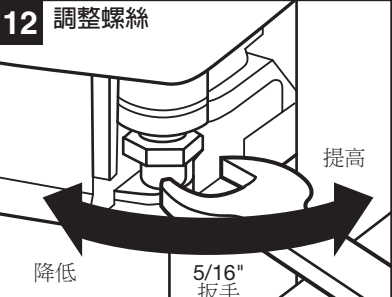

提高 (Increase)
降低 (Decrease)
5/16" 扳手

*TORX 和 T30 是 Acument Intellectual Properties, LLC. 的註冊商標。

拆卸冰箱門

如果您的冰箱無法順利穿越住家的出入口或準備丟棄舊冰箱，請依



照以下步驟來拆卸冰箱門。

1. 拔下冰箱的插頭，或切斷電源。
2. 將兩邊的冰箱門全開。請見圖 1。
3. 如果您的機型有飲水機功能，請將濾水器門朝您的方向拉動來打開它。請見圖 2。拆卸濾水器本體不是必要的步驟。
4. 將底座格柵從側面朝您的方向拉動，接著從中間朝您的方向拉動，直到它退出為止。請見圖 2。
5. 若要拆卸底座格柵，扭動並拉動右側，直到該側從冰箱門下方穿出為止。請見圖 3。接著拉動底座格柵的左側，即可完全取出。
6. 如果您的機型有門內飲水機功能，請拔掉冷凍室門下方的飲水機管線。
 - 沿著接管面壓下藍色外環，拉出飲水機管線。請見圖 4。**備註：**讓水管接頭持續連接在冷凍室下方的管線。如果接頭仍然連接至穿越冰箱門轉軸下的管線，就無法拆卸冰箱門。
7. 如果您的機型有門內飲水機功能，請拔掉冷凍室門下方的線路。請見圖 5。
 - 使用 1/4" 六角頭套筒扳手來拆卸線路夾和線架。
 - 拔除線架線路的線路插頭。
8. 關閉冷凍室門並使用 TORX⁺ T30 螺絲起子以拆卸上方轉軸。請見圖 6。**重要事項：**請勿拆卸任何一個螺絲 A。拆卸轉軸時，請握住冰箱門。
9. 垂直抬高冷凍室門，使其離開下方轉軸。請見圖 7。飲水機管線和線路會繼續連接至冷凍室門。**備註：**可能需要兩名人員來操作，其中一名人員抬高冰箱門，另一位人員將水管和線路放入下方的轉軸插腳處。**重要事項：**將冰箱門的一側放在柔軟、乾淨的表面上（如毛巾、毛毯或一片紙板）。如此可避免造成冰箱門、水管和線路的刮傷或損壞。
10. 關閉冰箱門並使用 TORX⁺ T30 螺絲起子以完全拆卸上方轉軸。請見圖 8。**重要事項：**請勿拆卸任何一個螺絲 A。拆卸轉軸時，請握住冰箱門。
11. 垂直抬高冰箱門，使其離開下方轉軸。請見圖 7。**重要事項：**將冰箱門的一側放在柔軟、乾淨的表面上（如毛巾、毛毯或一片紙板）。如此可避免造成冰箱門的刮傷或損壞。
12. 如果您的冰箱在沒有冰箱門的狀態下仍然無法穿過出入口，您可能要一併拆卸兩個下方轉軸。使用 5/16" 螺帽扳頭來拆卸這些部位。請見圖 9。**重要事項：**請勿拆卸任何一個螺絲 B。

更換或重新安裝冰箱門與轉軸

如果您的冰箱門和下方轉軸已經拆卸，請依照後續指示來重新安裝：

1. 使用 5/16" 螺帽扳頭來拴緊螺絲，重新安裝兩個下方轉軸。請見圖 9。
2. 如果您的機型有門內飲水機功能：
 - 將冷凍室門抬高，使其到足以將飲水機管線與線路穿過下方轉軸插腳處的高度。**備註：**可能需要兩名人員來操作，其中一名人員抬高冰箱門，另外一位人員將水管和線路放入下方轉軸插腳處。請見圖 7。
 - 將冷凍室門插入下方轉軸插腳處。**重要事項：**安裝轉軸時，請握住冰箱門
3. 再次關上冷凍室門來對齊並重新安裝上方轉軸。使用 TORX⁺ T30 螺絲起子來拴緊螺絲。請見圖 8。**重要事項：**重新安裝上方轉軸時，請提供冰箱門更多的支撐。不要依靠冰箱門的磁鐵來確定冰箱門與櫥櫃兩者貼合。
4. 如果您的機型有門內飲水機功能，請連接飲水機管線。若要連接，請將管線推入飲水機管線內，直到黑色標記觸碰到接管面為止。請見圖 4。
5. 連接線路。請見圖 5。
6. 使用 1/4" 六角頭套筒扳手來重新安裝線路夾和線架。
7. 連接線架線路的線路插頭。
8. 將冰箱門抬高，使其到足以將冰箱門插入下方轉軸插腳處的高度。請見圖 7。**重要事項：**安裝轉軸時，請握住冰箱門。
9. 再次關上冰箱門來對齊並重新安裝上方轉軸。使用 TORX⁺ T30 螺絲起子來拴緊螺絲。請見圖 6。**重要事項：**重新安裝上方轉軸時，請提供冰箱門更多的支撐。不要依靠冰箱門的磁鐵來確定冰箱門與櫥櫃的貼合程度。

水平調整和冰箱門關閉

您的冰箱有兩個可調整的前輪。請見圖 1。

這些輪子是用來在不平坦的地面上水平調整冰箱而設計，也可以讓冰箱門更輕鬆地關上。請依照以下指示：

1. 使用氣泡水平儀來檢查冰箱後側放置之地面的平坦程度。如果冰箱無法平放，請進行調整或在地面上增加填隙木片來為後輪提供平坦的地面。水平調整過的後側可避免冰箱櫥櫃形成歪曲。
2. 將冰箱放置在廚房內的預定位置，並打開兩邊的冰箱門。
3. 將兩邊的冰箱門全開。請見圖 1。
4. 如果您的機型有門內飲水機功能，請將濾水器門朝您的方向拉動來打開它。請見圖 2。拆卸濾水器本體不是必要的步驟。
5. 將底座格柵從側面朝您的方向拉動，接著從中間朝您的方向拉動，直到它退出為止。請見圖 2。
6. 若要拆卸底座格柵，扭動並拉動右側，直到該側從冰箱門下方穿出為止。請見圖 3。接著拉動底座格柵的左側，即可完全取出。
7. 其中一人提高輪子，另一人將冰箱推入以便從前側抬起。使用冰箱上方或側面的氣泡水平儀來調整冰箱的水平。檢查氣泡水平儀，同時觀察與鄰近櫥櫃、傢俱或飾條之間的間隙和垂直程度。如果鄰近傢俱不是水平的，當產品已呈水平，可能就無法達成均勻的間隙。持續調整，直到四個角落穩定平放而不搖晃。
8. 使用 3/8" 螺帽扳頭來旋轉位於冰箱兩側裡的水平調整螺絲。請見圖 10。您必須將其中一個或全部兩個螺絲向右旋轉或向左旋轉，才能提高或降低冰箱（根據不平坦的地面狀況，可能須嘗試數次）。
9. 將兩道冰箱門全部關上，確定關門時可以輕鬆關上。如果無法輕鬆關上，將兩邊的螺絲向右旋轉來提高冰箱，向後傾斜直到冰箱門可以輕鬆關上為止。
10. 將底座格柵凹槽處組裝至櫥櫃前，請先檢查並確定技師資料表已置於其中。

- 將底座格柵重新安裝至櫥櫃裡，先放入底座格柵的左側，接著再放入右側。請見圖 3。您可以將飲水機管線和線路放入左下轉軸下方的底座格柵凹槽處。
- 接入底座格柵，推進櫥櫃夾內。請見圖 2。

冰箱門的對齊

當冰箱清空時，冰箱門的設計是會產生垂直部分些微不對齊的情況。請依照以下步驟來對齊冰箱門。

- 使用 11/16" 開口扳手工具來鬆開位於冰箱門下方的鎖定螺帽。請見圖 11。調整扳手工具，使其可在有限的空間內使用。
- 使用 5/16" 開口扳手工具來旋轉對齊螺絲。請見圖片 12。您必須將螺絲向右旋轉來提高或向左旋轉來降低冰箱門，直到兩邊冰箱門均已垂直對齊（視冰箱門與冷凍室門之間不對齊的程度而定）。
- 用扳手工具拴緊 11/16" 鎖定螺帽。
- 如果底座格柵退出，請將其接入。

把手安裝與拆卸

零件包含：冰箱門把手 (2)、1/8" 六角鑰匙、備用固定螺絲

若要安裝把手：

備註：把手安裝固定螺絲已預先安裝在把手中。

- 取出位於冰箱內部的把手。
備註：為了避免刮傷烤漆，請將把手放置在毛巾或其他柔軟表面上。
- 打開冷凍室門。在冰箱門上，將把手放置在有肩螺絲上，且固定螺絲要面朝冷凍室。

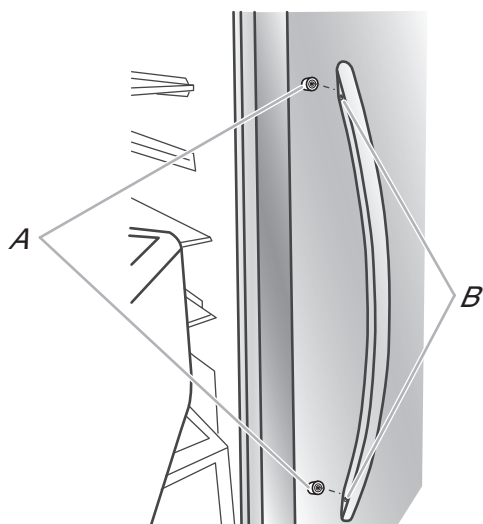

A. 有肩螺絲
B. 把手內固定螺絲

- 穩固地將把手朝冰箱門方向推，直到把手底座與冰箱門齊平為止。
- 握住把手時，請將六角鑰匙較短的一端插入上方洞口並微微旋轉六角鑰匙，直到鑰匙在固定螺絲中啮合為止。

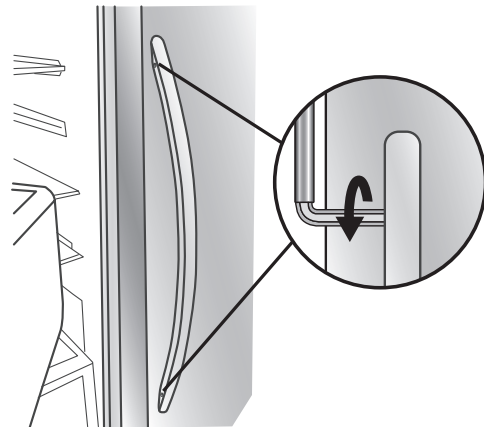

- 以順時針方向拴緊固定螺絲，直到固定螺絲開始接觸有肩螺絲為止。
- 重複步驟 4 和 5，開始鎖緊下方固定螺絲。
- 一旦兩邊固定螺絲均已部分拴緊（如先前步驟所示），即可完全拴緊上下兩個固定螺絲。
重要事項：當您覺得螺絲變緊時，請再額外拴緊四分之一圈。如果沒有這道手續，把手就不算正確安裝。
- 打開冰箱門，關上冷凍室門。重複步驟 2 至 7，將另一邊的把手安裝在冷凍室門上，且固定螺絲要面朝冰箱。
- 妥善保存六角鑰匙和所有的指示。

若要拆卸把手：

- 握住把手時，請將六角鑰匙較短的一端插入下方固定螺絲洞口並微微旋轉六角鑰匙，直到鑰匙在固定螺絲中啮合為止。
- 以逆時針方向鬆開固定螺絲，每次鬆開四分之一圈。
- 重複步驟 1 和 2 來鬆開上方固定螺絲。輕輕將把手拉離冰箱門。
- 如有必要，請使用十字螺絲起子來拆卸門上的有肩螺絲。

位置要求

警告



爆炸危險

易燃材料和類似汽油的蒸氣應存放於遠離冰箱之處。
否則可能導致人員死亡、爆炸或起火。

重要事項：此冰箱的設計僅供家庭於室內使用。

為了讓冰箱有良好的通風，冰箱每一側和上方至少要有 1/2" (1.27 公分) 的空間。冰箱後方要有 2" (5.08 公分) 的空間。如果您的冰箱有製冰機，請在後方預留額外的空間讓供水管線連接。在固定牆面旁安裝冰箱時，每一側要預留至少 2" (5.08 公分) 的空間 (視您的機型而定) 來讓冰箱門打開。

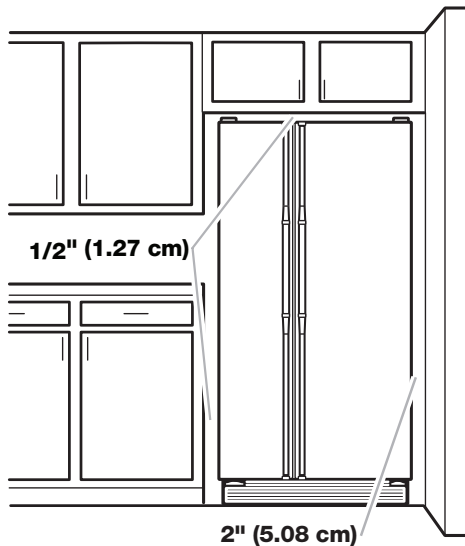

備註：

- 這部冰箱主要用於溫度範圍介於最低 55°F (13°C) 至最高 110°F (43°C) 之間的環境裡。若要獲得理想效能 (降低電力使用量並提供出色的冷卻效果)，則偏好的室溫範圍會是介於 60°F (15°C) 和 90°F (32°C) 之間。建議不要在熱源 (如烤箱或電暖器) 附近安裝冰箱。
- 產品安裝所需的正常最小櫥櫃放置寬度為 36" (91.44 公分)。然而，如果產品放置在延伸牆面旁，而您要取出外蓋微波盤，則必須要有額外 18" (45.72 公分) 的櫥櫃寬度，因此建議櫥櫃開口總寬度為 54" (137.16 公分)。

電氣需求

警告



觸電危險

- 插入至接地插座。
- 請勿拔下接地插腳。
- 請勿使用變壓器。
- 請勿使用延長線。
- 違反這些指示可能導致人員傷亡、失火或觸電。

在將冰箱移至最終位置之前，請務必確保您的電氣連接正確。

建議接地方式

要求 115V、60Hz、純交流電、15 A 或 20 A 帶保險絲的接地電源。建議提供僅用於冰箱的個別電路。使用無法透過開關關閉的插座。請勿使用延長線。

備註：在執行任何類型的安裝或清潔或卸下燈泡之前，請先從電源中斷冰箱的電力連接。當您完成時，將冰箱重新連接到電源，並將控制項 (溫控器、冰箱或冷凍室控制，視機型而定) 重置為所需設定。請參閱《使用者指示》、《使用者指南》或《使用與保養指南》中的「使用控制項」一節。

供水要求

在開始安裝之前，請準備好所需的工具與零件。仔細閱讀並遵照製造商提供的說明，使用以下列舉的工具。

所需工具：

- 一字螺絲刀
- 7/16" 和 1/2" 開口扳手或兩個可調整的扳手
- 1/4" 螺帽扳頭
- 1/4" 鑽頭
- 無線電鑽

備註：您的冰箱經銷商提供了一種套件，該套件有 1/4" (6.35 公釐) 鞍形截止閥、活管套節和銅管。購買前，請確保鞍形閥符合當地的衛生設備規範。請勿使用會降低水流量並更容易堵塞的沖孔式或 3/16" (4.76 公釐) 鞍形閥。

重要事項：

- 所有安裝都必須符合當地的衛生設備規範要求。
- 使用銅管並檢查是否洩漏。僅可在居家溫度會保持於冰點以上的區域安裝銅管。

水壓

要操作飲水機和製冰機，需要水壓介於 30 psi 和 120 psi (207 kPa 至 827 kPa) 之間的冷水供應。如果您對水壓有疑問，請洽詢有執照的合格管道工。

- 如果您的冰箱配有飲水機：安裝完成後，使用飲水機檢查水壓。
 - 取下濾水器後，分配 1 杯 (237 mL) 的水。如果在 8 秒或更短的時間內分配了 1 杯水，則冰箱的水壓達到最低要求。
 - 如果分配 1 杯水所需的時間超過 8 秒，則冰箱的水壓低於建議值。請參閱「問題解決方案」以取得更多建議。

逆滲透供水

重要事項：從逆滲透系統通往冰箱進水閥的供水壓力必須介於 30 psi 與 120 psi (207 kPa 和 827 kPa) 之間。

如果逆滲透濾水系統連接至您的冷水供應，則逆滲透系統的水壓必須至少為 40 psi 到 60 psi (276 kPa 至 414 kPa)。

如果逆滲透系統的水壓低於 40 psi 至 60 psi (276 kPa 至 414 kPa)：

- 檢查逆滲透系統中的沉澱物過濾器是否堵塞。如有必要，請更換過濾器。
- 大量使用後，請重新填充逆滲透系統上的儲罐。
- 如果您的冰箱裝有濾水器，當與逆滲透系統結合使用時，它可能會進一步降低水壓。拆卸濾水器。請參閱《使用者指示》、《使用者指南》或《使用與保養指南》中的「濾水系統」。

如果您對水壓有疑問，請洽詢有執照的合格管道工。

連接供水

開始之前請先閱讀所有說明。

重要事項：

請勿在未經適當消毒之前，在進出系統前後使用內含不安全微生物或有品質疑慮用水。經認證可有效降低孢囊數量的系統，得用於可能含有可過濾孢囊之已消毒用水。

- 僅可連接到飲用水供應源。
- 管道的安裝應遵循國際衛生設備規範以及任何當地法規和條例。
- 冰箱背面的灰色水管（用來連接家用供水管線）為塑膠管線。從家用供水管線到冰箱之間的連結，可以使用銅管和塑膠管線，這將有助於避免冰塊或水的味道走樣或產生怪味。檢查洩漏。如果使用塑膠管線代替銅管，我們建議使用以下 Whirlpool 零件編號：
W10505928RP (7 英尺 [2.14 公尺] 夾套塑料)、
8212547RP (5 英尺 [1.52 公尺] 塑料)，或
W10267701RP (25 英尺 [7.62 公尺] 塑料)。
- 僅可在溫度會保持於冰點以上的區域安裝管線。

所需工具：

在開始安裝之前，請準備好所需的工具與零件。

- 一字螺絲刀
- 7/16" 和 1/2" 開口扳手或兩個可調整的扳手
- 1/4" 螺帽扳頭

連接至供水管線

重要事項：如果您在連接供水管線之前啟動冰箱，請關閉製冰機。

樣式 1 (建議)

1. 拔下冰箱的插頭，或切斷電源。
2. 關閉主要供水。打開最近的水龍頭，時間要長到足以清理供水線路內的髒污。
3. 使用四分之一圈的截止閥或同等的截止閥，以 1/2" 的銅質家用供應管線來提供。

備註：為了使足夠的水流到冰箱，建議使用最小 1/2" 尺寸的銅質家用供應管線。

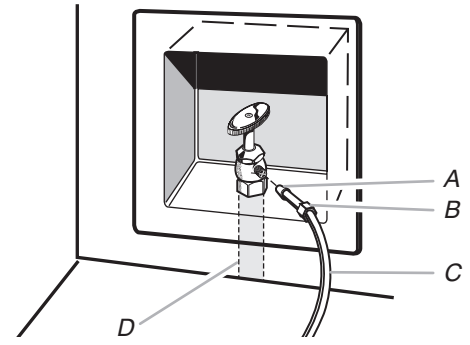

A. 燈泡 C. 銅管 (至冰箱)
B. 螺帽 D. 家用供應管線 (至少 1/2")

4. 現在，您可以將銅管連接到截止閥了。使用外徑為 1/4" (6.35 公釐) 的軟銅管來連接截止閥和冰箱。
 - 確定您有作業所需的適當長度。務必將銅管的兩端切成方形。
 - 如圖所示，將壓縮套和壓縮螺帽滑到銅管上。將管道末端盡可能直地插入出口末端。用活動扳手將壓縮螺帽控到出口端。不要拴得太緊。

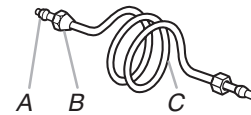

A. 壓縮套 C. 銅管
B. 壓縮螺帽

5. 將管道的自由端放入容器或水槽中，然後打開主供水以沖洗管道，直到水洗淨為止。關閉水管上的截止閥。

備註：在最終連接至水閥進口之前，請務必先排空水管，以免水閥發生故障。

6. 彎曲銅管，使其與進水管線入口相接，進水管線入口位於冰箱櫃體的背面，如圖所示。留下一卷銅管，以便將冰箱從機櫃中拉出或從牆壁上拉開以進行維修。

樣式 2

1. 拔下冰箱的插頭，或切斷電源。
2. 關閉主要供水。打開最近的水龍頭，時間要長到足以清理供水線路內的髒污。
3. 在冰箱附近，找出 1/2" (1.27 公分) 至 1 1/4" (3.18 公分) 的垂直冷水管。

重要事項：

- 確定它是冷水管。
 - 水平管道可以使用，但要在管道的頂部而不是底部鑽孔。這將有助於使水遠離鑽頭，並使正常的沉積物不會積聚在閥門中。
4. 確定所需的銅管長度。從冰箱左下角到水管的連接處進行測量。增加 7 英尺 (2.1 公尺) 以進行清潔。使用外徑為 1/4" (6.35 公釐) 的銅管。務必將銅管的兩端切成方形。

5. 使用無線電鑽在您選擇的冷水管上鑽一個 1/4" (6.35 公分) 的孔。

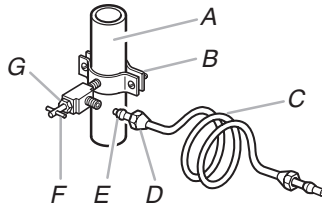

- A. 冷水管
B. 管夾
C. 銅管
D. 壓縮螺帽
E. 壓縮套
F. 截止閥
G. 襯墊螺帽

6. 用管夾將截止閥固定在冷水管上。確保出口端牢固地固定在水管的 1/4" (6.35 公釐) 鑽孔中，並且墊圈在管夾下方。拴緊襯墊螺帽。緩慢均勻地拴緊管夾螺釘，以便墊圈形成水密封。不要拴得太緊，否則可能會壓壞銅管。
7. 如圖所示，將壓縮套和壓縮螺帽滑到銅管上。將管線的末端盡可能直地插入出口端。用活動扳手將壓縮螺帽拴到出口端。不可拴得太緊。
8. 將管道的自由端放在容器或水槽中，然後打開主供水系統。沖洗油管，直到沒有水為止。關閉水管上的截止閥。盤繞銅管。

連接冰箱

樣式 1

1. 拔下冰箱的插頭，或切斷電源。
2. 取下並丟棄水管入口末端的黑色塑料短部分。
3. 將螺帽拴到管道的末端。用手拴緊螺帽。然後再用扳手拴緊兩圈。不可拴得太緊。

備註：為避免嘎嘎作響，請確保銅管不會碰到機櫃的側壁或機櫃內的其他零件。

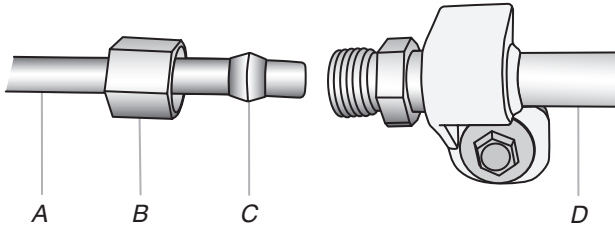

- A. 家用供水管線
B. 螺帽 (已購買)
C. 套圈 (已購買)
D. 冰箱水管

4. 將供水管夾安裝在供水管線周圍，以減少聯軸器上的應變。
5. 打開截止閥。
6. 檢查洩漏拴緊所有洩漏的連接件（包括閥門的連接件）或螺母。

樣式 2

1. 拔下冰箱的插頭，或切斷電源。
2. 卸下並丟棄連接到水閥入口的塑料部件。
3. 如圖所示，使用壓縮螺母和襯套將銅管連接到閥入口。拴緊壓縮螺母。不可拴得太緊。
4. 如圖所示，使用冰箱背面的管夾將管子固定到冰箱。當冰箱向後推向牆壁時，這將有助於避免損壞管路。
5. 打開截止閥。

6. 檢查洩漏拴緊所有洩漏的連接件（包括閥門的連接件）或螺母。

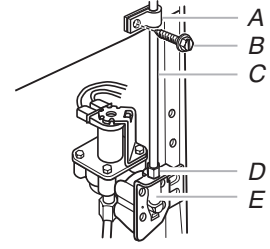

- A. 管夾
B. 管夾螺絲
C. 銅管
D. 壓縮螺帽
E. 進水閥

7. 在某些機型上，製冰機配有內置濾水器。如果您的水條件需要第二個濾水器，則將其安裝在任一管連接處的 1/4" (6.35 公釐) 水管中。從附近的電器經銷商處獲得濾水器。

樣式 3

1. 拔下冰箱的插頭，或切斷電源。
2. 從冰箱後部的灰色水管上卸下黑色尼龍塞，並將其丟棄。
3. 如果冰箱隨附的灰色水管不夠長，則需要 1/4" x 1/4" (6.35 公釐 x 6.35 公釐) 聯軸器才能將水管連接至現有的家用供水管線。將提供的螺母拴到銅管末端的接頭上。

備註：用手拴緊螺帽。然後再用扳手拴緊兩圈。不要拴得太緊。

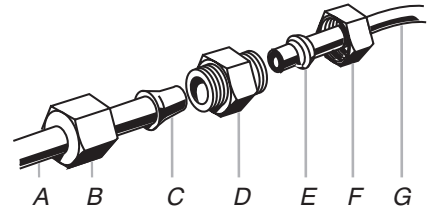

- A. 冰箱水管
B. 螺帽 (已提供)
C. 燈泡
D. 聯軸器 (已購買)
E. 套圈 (已購買)
F. 螺帽 (已購買)
G. 家用供水管線

4. 打開截止閥。
5. 檢查洩漏拴緊所有洩漏的螺母或連接件（包括閥門的連接件）。

完成安裝

警告



觸電危險

- 插入至接地插座。
請勿拔下接地插腳。
請勿使用變壓器。
請勿使用延長線。
違反這些指示可能導致人員傷亡、失火或觸電。

1. 將插頭插入一個 3 孔的接地電源插座。
2. 沖洗水系統。請參閱《使用者指示》或《使用者指南》中的「飲水機和冰塊分配機」。

備註：需要 24 小時才能生產出第一批冰塊。需要 72 小時才能完全填滿冰塊容器。

操作冰箱

使用控制項

為了方便起見，您的冰箱控制項在出廠時已預先設定完畢。首次安裝冰箱時，請確保控制項仍處於預設狀態。Refrigerator Control (冰箱控制項) 和 Freezer Control (冷凍室控制項) 均應設定為「中間設定」。

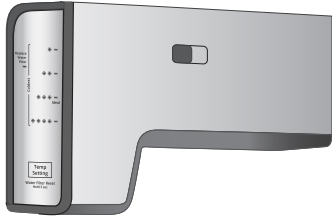

REFRIGERATOR (冰箱)

FREEZER (冷凍室)

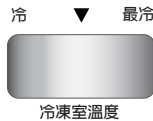
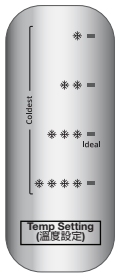

重要事項：

- Refrigerator Control (冰箱控制項) 可調節冰箱冷藏室的溫度。每按一下 Temp Setting (溫度設定) 按鈕，就會讓冰箱冷藏室變得更冷 (1 個雪花的 LED 指示燈亮起表示最不冷 / 2、3 或 4 個雪花的 LED 指示燈亮起表示較冷 / 所有 LED 指示燈亮起表示最冷)，一旦您達到最後一個級別，再按一下就會讓系統返回初始級別。

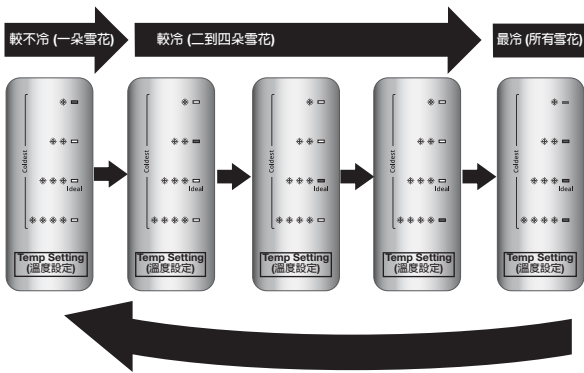

- Freezer Control (冷凍室控制項) 可調節冷凍室的溫度。設定到中間設定的前面可使溫度變得較不冷。設定到中間設定的後面可使溫度變得較冷。
- 請先等待 24 小時，再將食物放入冰箱。如果在冰箱完全冷卻之前放入食物，則食物可能變質。

備註：將冰箱和冷凍室控制項調到高於建議設定的位置 (較冷) 不會讓冷藏室或冷凍室冷得更快。

調整控制項

在放入食物之前，請給冰箱時間完全冷卻。最好先等待 24 小時，再將食物放入冰箱。上一節中指出的設定對於家用冰箱的正常使用應該是正確的。若牛奶或果汁的溫度是您喜歡的，而且冰淇淋也定形，表示已正確設定控制鍵。

如果您需要調整冰箱的溫度，請使用下表所列出的設定作為指南。在調整作業之間等候最少 24 小時。

條件/原因：	調整：
冰箱過熱	冰箱控制項的設定高一級
冷凍室過熱 / 冰塊太少	冷凍室控制項的設定高一級
冰箱過冷	冰箱控制項的設定低一級
冷凍室過冷	冷凍室控制項的設定低一級

保鮮濕度控制 (在某些機型上)

您可以控制濕氣密封的保鮮盒中的濕度。將控制項調整為 Low (低) 和 High (高) 之間的任何設定。

Low (低)(開啟) 適合存放有皮的水果和蔬菜。

High (高)(關閉) 適合存放新鮮葉類蔬菜。

冰箱保養

清潔

警告



爆炸危險

火灾或爆炸风险。

所用易燃制冷剂。

请勿使用机械设备为冰箱除霜。

请勿穿刺制冷剂管道。

冰箱和冷凍室部分均有自動除霜。但是，每個月大約清潔兩個部分，以免產生異味。立即擦拭外溢物品。

重要事項：因為空氣在兩個部分之間循環，所以在一個部分中形成的任何氣味都會轉移到另一部分。您必須徹底清潔兩個部分，以消除異味。為避免氣味傳播和食物乾燥，請緊緊包裹或蓋好食物。

若要清潔冰箱：

備註：請勿在塑膠部位、內部和門襯或墊圈上使用研磨性或刺激性的清潔劑，例如窗戶噴霧劑、去污清潔劑、易燃液體、清潔蠟、濃縮清潔劑、漂白劑或含有石油產品的清潔劑。請勿使用紙巾、菜瓜布或其他研磨性清潔工具。

1. 拔下冰箱的插頭，或切斷電源。
2. 徹底用手洗、沖洗和拭乾可拆除的零件和內部表面。用清潔的海綿或軟布、溫和清潔劑和溫水。
3. 用乾淨的海綿或軟布和中性清潔劑在溫水中清洗不銹鋼和帶漆金屬外表面。

警告



爆炸危險

因穿刺制冷剂管道引起的火灾或爆炸风险；

仔细遵循处理说明。

所用易燃制冷剂。

- 在正常的家庭操作環境中，無需定期清潔冷凝器。如果環境特別油膩或多塵，或者家裡有大量寵物出沒，則冷凝器應每 2 到 3 個月清潔一次，以確保最大效率。

如果需要清潔冷凝器：

- 取出底座格柵。請參閱《使用者指示》或《安裝指示和使用手冊》中、或冰箱隨附的單獨說明表中的「冰箱門拆卸」指示。
- 使用帶有軟刷的真空吸塵器清潔格柵，格柵後面的開口區域和冷凝器的前表面區域。
- 完成後，請裝回底座格柵。

- 插上冰箱插頭，或重新連接電源。

燈光

室內燈損壞時請聯繫授權的服務代理商要求更換室內燈，非專業服務人員不得更換室內燈。

假期和搬家保養

假期

如果您選擇在外出時讓冰箱繼續運轉：

- 食用任何易腐食品並冷凍其他物品。
- 若冰箱有連接至住宅水源的自動製冰機，關閉連接至冰箱的水源。未關閉水源可能導致財產毀損。
- 若有自動製冰機，關閉它。

備註：將斷線臂提高到 OFF (上) 的位置或按下開關到 OFF (右) 的位置 (視您的機型而定)。

- 清空冰桶。

如果您選擇在外出前讓冰箱停止運轉：

- 從冰箱取出所有食物。
- 若冰箱配備自動製冰機：
 - 至少提前一天關閉製冰機的供水。
 - 當最後一顆冰塊落下時，將斷線臂提高到 OFF (上) 的位置或將開關移至 OFF (右) 的設定。
- 拔下冰箱插頭。
- 清潔、擦拭並完全乾燥。
- 在兩邊冰箱門的頂部貼上橡膠或木塊，撐開到足以使空氣能夠進入的寬度。這可以防止異味和黴菌積聚。

搬運

搬運冰箱至新家時，遵循下列步驟，做好搬動的準備。

- 若冰箱配備自動製冰機：
 - 至少提前一天關閉製冰機的供水。
 - 從冰箱背面斷掉供水管線的連結。

- 當最後一顆冰塊落下時，將斷線臂提高到 OFF (上) 的位置或將開關移至 OFF (右) 的設定。
- 從冰箱中取出所有食物，然後將所有冷凍食物裝在乾冰中。
 - 清空冰桶。
 - 拔下冰箱插頭。
 - 清潔、擦拭並完全乾燥。
 - 取出所有可移動部件，將它們包好，然後用膠帶粘在一起，以免它們在移動過程中移動或發出嘎嘎聲。
 - 根據型號的不同，抬高冰箱的前部，使其更容易滾動，或者拴入調平腳，以免刮傷地板。請參閱「調整冰箱門」或「拆除冰箱門、水平調整與對齊」。
 - 用膠帶將門關閉，然後將電源線粘貼到冰箱的背面。

當您回到新家時，將所有物品放回原處，並參閱安裝說明中的準備說明。此外，若您的冰箱配備自動製冰機，記得重新將水源連接至冰箱。

冷凍架

(架子數量因機型而異)

卸下和更換底架：

- 提起機箱的前部和後部，然後從機櫃中取出。務必不要卸下固定桿。
- 更換架子，使桿子與櫥櫃格架對齊。在架子上施加一點壓力，將桿連接到櫥櫃的格架上。

若要拆卸並更換中層和頂層架：

- 用手將架子從底部推到頂部，直到將其從固定桿上鬆開。拉動架子，直至其從後桿上鬆開。從櫥櫃中取出。
- 若要更換架子：

- 將桿更換到支撐孔中。向下推動拉桿，使其卡入孔中。
- 找出架子的前後飾條。

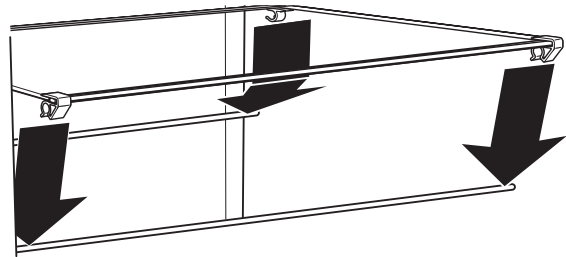

- 將後飾條放在後拉桿上，然後推架子，使其將拉桿卡入飾條後端。(推動時保持前部抬起)。
- 放低架子前端，直到前飾條位於拉桿上為止，然後向下推，使它將拉桿卡入飾條後端。

備註：確保將架子的兩側均勻地放置在架子支撐孔中，並固定架子。

疑難排解

請先嘗試此處建議的解決方案或造訪我們的網站，以免產生服務電話的費用。

 **警告**



觸電危險

- 插入至接地插座。
- 請勿拔下接地插腳。
- 請勿使用變壓器。
- 請勿使用延長線。
- 違反這些指示可能導致人員傷亡、失火或觸電。

一般操作

可能的原因和/或建議的解決方案

冰箱無法運轉

- **未連接至電源** - 將電源線插入 3 孔的接地電源插座。請勿使用延長線。
- **電源插座無電** - 插入燈以查看電源插座是否正常運作。
- **家用保險絲燒斷或斷路器跳閘** - 更換保險絲或重設斷路器。如果問題仍然存在，請聯繫有執照的電工。
- **全新安裝** - 安裝後，請等候 24 小時讓冰箱和冷凍室完全冷卻。
備註：將溫度控制調節到最冷的設置不會更快地冷卻任一隔室（冰箱或冷凍室）。

馬達似乎過度運轉

- **您的新冰箱具有節能馬達** - 冰箱的運行時間可能比以前更長，因為壓縮機和風扇以較低的速度運行，因此更加節能。這是正常現象。
備註：如果房間較暖、放入大量食物，經常開冰箱門或讓冰箱門敞開，冰箱的運作時間可能甚至會更長。

冰箱好像太吵

與舊型號相比，新冰箱中的壓縮機可更有效地調節溫度，並消耗更少的能量。在操作的各個階段，您可能聽到不熟悉的正常操作聲音。

以下噪聲是正常現象：

- **嗡嗡聲/咔嗒聲** - 當水閥打開和關閉以分配水或填補製冰機時會聽到。如果冰箱已連接到供水管線，這是正常現象。如果冰箱未連接到供水管線，請關閉製冰機。
- **破裂聲/碰撞聲** - 從製冰機模具中彈出冰塊時聽到。
- **爆裂聲** - 在內壁收縮/膨脹時聽到的聲音，尤其是在初始冷卻期間。
- **脈動聲/迴旋聲** - 在正常運行期間調節風扇/壓縮機以最佳化性能時聽到。
- **嘎嘎聲** - 當水通過輸水管線或由於冷媒流動而聽到。嘎嘎聲也可能來自放在冰箱頂部的物品。
- **水流聲或咕嚕聲** - 在除霜過程中冰融化並且水流入排水盤時聽到。
- **嘶嘶聲** - 在除霜過程中，當水滴到加熱器上時聽到。

一般操作	可能的原因和/或建議的解決方案
溫度太暖	<ul style="list-style-type: none"> ■ 全新安裝 - 安裝後，請等候 24 小時讓冰箱和冷凍室完全冷卻。 備註：將溫度控制調節到最冷的設定，不會更快地冷卻任一隔室 (冰箱或冷凍室)。 ■ 冰箱門經常打開或沒有完全關閉 - 這使熱空氣進入冰箱。讓冰箱門的開口保持在最小的狀態、讓門完全關閉，並確保兩扇冰箱門都正確密封。 ■ 通風孔被阻塞 - 移除通風孔前面的物品。 ■ 最近放入了大量的熟食 - 冰箱要等待幾個小時才能恢復到正常溫度。 ■ 控制項並未針對周圍環境正確設定 - 調整控制項為較冷的設定。於 24 小時內再次檢查溫度。
溫度太冷	<ul style="list-style-type: none"> ■ 控制項並未針對周圍環境正確設定 - 調整控制項為較暖的設定。於 24 小時內再次檢查溫度。 ■ 頂部冰箱架比下部冰箱架更冷 - 在某些機型上，來自冷凍室的空氣會通過頂部冰箱架附近的通風口進入冷藏室。結果，上層架可能比下層架更冷一些。 ■ 通風孔被阻塞 - 移除通風孔前面的物品。
內部水分積聚	<p>備註：某些水分積聚是正常的。用柔軟的乾布清潔。</p> <ul style="list-style-type: none"> ■ 房間潮濕 - 潮濕的環境會導致水分積聚。只能在室內且濕度盡可能小的室內使用冰箱。 ■ 冰箱門經常打開或沒有完全關閉 - 這使濕空氣進入冰箱。讓冰箱門的開口保持在最小的狀態、讓門完全關閉，並確保兩扇冰箱門都正確密封。
內部燈光無法運作	<ul style="list-style-type: none"> ■ 冰箱門已經打開了很長一段時間 - 關上冰箱門以重置燈光。 ■ 燈泡在插座中鬆動或燒壞 - 在帶有白熾內部的機型上，拴緊或更換燈泡。請參閱「燈光」一節。 <p>備註：在帶有迷你 LED 燈的機型上，如果任一扇冰箱門打開時內部燈光都未點亮，請尋求協助或維修。請參閱《使用者指示》或《使用者指南》中的「保固」以取得聯絡資訊。</p>
飲水機燈光無法運作 (在某些機型上)	<ul style="list-style-type: none"> ■ Dispenser light is turned off - On some models, if the dispenser light is set to OFF, the light will turn on only when a dispenser pad/lever is pressed. If you want the dispenser light to stay on continuously, select a different setting. 請參閱《使用者指示》或《使用者指南》中的「飲水機和冰塊分配機」。 ■ 飲水機燈光設定為 AUTO (自動) 或 NIGHT LIGHT (夜光)- 在某些機型上，如果飲水機燈光設定為 AUTO (自動) 或 NIGHT LIGHT (夜光)，請確定飲水機燈光感應器並未被遮蔽。請參閱《使用者指示》或《使用者指南》中的「飲水機和冰塊分配機」。 <p>備註：在帶有迷你 LED 燈的機型上，如果飲水機燈光未正常運作，請尋求協助或維修。請參閱《使用者指示》或《使用者指南》中的「保固」以取得聯絡資訊。</p>

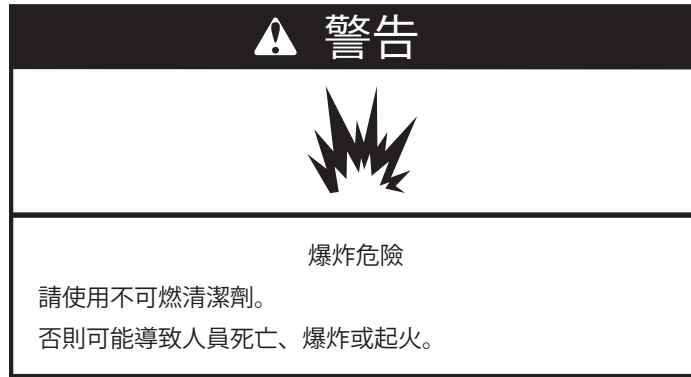

冰箱門和水平調整

可能的原因和/或建議的解決方案

冰箱門很難打開

- 墊圈變髒或變黏 - 用中性肥皂和溫水清潔墊圈和接觸面。沖洗並用柔軟布料擦乾。

冰箱門不會完全關上

- 冰箱門被阻隔而無法關上 - 讓食物包裝遠離冰箱門。確定所有盒子與架子都在正確的位置。確定已移除所有包裝材料。

冰箱門似乎不平坦

- 冰箱門必須對齊，或冰箱必須調整水平 - 請參閱水平調整和冰箱門的對齊指示。

冰箱搖晃且不穩定

- 冰箱不是水平的 - 要穩定冰箱，請拆卸底部格柵並放低水平調整腳，直到它們接觸地板為止。請參閱水平調整和冰箱門的對齊指示。



冰塊與水

可能的原因和/或建議的解決方案

製冰機並未製造冰塊、未製造足夠的冰塊或製造出小型/空心的冰塊

- 冰箱未連接到供水系統，或者供水截斷閥未完全打開 - 將冰箱連接到供水系統，並確保供水截斷閥已完全打開。
- 水源管路中的扭結 - 水管路中的扭結會減少水流量，導致製冰量減少、小冰塊和/或中空或不規則形狀的冰。拉直供水管線。
- 製冰機未打開 - 打開製冰機。請參閱《使用者指示》或《使用者指南》中的「製冰機和儲冰盒」。
- 全新安裝 - 將冰箱連接到水源後，沖洗水系統。(請參閱《使用者指示》或《使用者指南》中的「飲水機和冰塊分配機」。)請等候 24 小時，讓冰塊開始製作。請等候 72 小時，讓完整的冰塊製作程序完成。丟棄產生的前三批冰塊。
- 最近取出了大量的冰塊 - 讓製冰機有足夠的時間製作更多的冰塊。
- 冰卡在製冰機的彈出器臂中 (某些機型) - 使用塑膠用具將冰塊從彈出器臂取出。
- 水壓不足 - 確認家庭有足夠的水壓。請參閱「供水要求」。
- 濾水器安裝不正確 - 確保濾水器安裝正確。請參閱《使用者指示》或《使用者指南》中的「濾水系統」。
- 逆滲透濾水系統已連接到您的冷水供應上 - 這可能會降低水壓。請參閱「供水要求」。

備註：如果水壓方面還是有疑問，請洽詢有執照的合格管道工。

冰塊與水

可能的原因和/或建議的解決方案

冰塊分配機無法正常運作

- **冰箱門未完全關閉** - 確保兩扇冰箱門均已穩固關閉。(在某些型號上，只有冷凍室門必須關閉才能操作分配機。)
- **全新安裝** - 將冰箱連接到水源後，沖洗水系統。(請參閱《使用者指示》或《使用者指南》中的「飲水機和冰塊分配機」。)請等候 24 小時，讓冰塊開始製作。請等候 72 小時，讓完整的冰塊製作程序完成。丟棄產生的前三批冰塊。
- **製冰機未打開，或儲冰盒未正確安裝** - 打開製冰機並確保儲冰盒牢固就位。請參閱《使用者指示》或《使用者指南》中的「製冰機和儲冰盒」。
- **冰在儲冰盒中被堵塞或凍結在一起，或者冰阻塞了送冰斜槽** - 如有必要，請使用塑料用具取出或分離堵塞的冰。用濕的濕布清潔出冰槽和儲冰盒底部。然後，將它們徹底擦乾。為避免堵塞並保持新鮮的冰塊供應，請每 2 週清空一次儲冰盒並清潔儲冰盒和輸送斜槽。
- **錯誤的冰塊已添加到儲冰盒中** - 僅限使用當前製冰機生產的冰塊。
- **分配機已鎖定** - 解鎖分配機。請參閱《使用者指示》或《使用者指南》中的「飲水機和冰塊分配機」。
- **冰塊分配機在分配碎冰時卡住** - 若為門上有儲冰盒的機型，暫時將碎冰切換為冰塊以排除卡住的情況。
- **分配機墊/槓桿被壓太久** - 冰塊會自動停止分配。等待幾分鐘使分配機重設，然後繼續分配。直接從儲冰盒中取出大量冰塊，而不要透過分配機。
- **進入房屋的水壓不超過 30 psi (207 kPa)** - 進入房屋的水壓影響分配機的流量。請參閱「供水要求」一節。
- **濾水器堵塞或安裝不正確** - 更換濾水器或正確安裝。請參閱《使用者指示》或《使用者指南》中的「濾水系統」。

冰或水有異味、 氣味或灰色

- **新的管道連接** - 新的管道連接可能會導致冰或水變味或變色。隨著時間的流逝，這個問題應該消失。
- **冰塊存放時間過長** - 丟棄冰塊並清洗儲冰盒。製冰機需要 24 小時來製造新的冰塊。
- **異味已從食物轉移** - 使用密封的防潮包裝來存儲食物。
- **使用非建議的供水管線** - 異味和味道會從非建議的供水管線中所使用的某些材料轉移。請僅使用建議的供水管線。請參閱「供水要求」一節。
- **水中有礦物質 (例如硫)** - 可能需要安裝濾水器以去除礦物質。
- **最近安裝或更換了濾水器** - 冰或水中的灰色或深色變色表明濾水系統需要額外沖洗。請參閱《使用者指示》或《使用者指南》中的「飲水機和冰塊分配機」。

飲水機無法正常運作

- **冰箱門未完全關閉** - 確保兩扇冰箱門均已穩固關閉。(在某些型號上，只有冷凍室門必須關閉才能操作分配機。)
 - **冰箱未連接到供水系統，或者供水截斷閥未打開** - 將冰箱連接到供水系統，並確保供水截斷閥已完全打開。
 - **水源管路中的扭結** - 水管路中的扭結會減少流向飲水機的水量。拉直供水管線。
 - **進入房屋的水壓不超過 30 psi (207 kPa)** - 進入房屋的水壓影響分配機的流量。請參閱「供水要求」一節。
 - **全新安裝** - 將冰箱連接到水源後，沖洗水系統。請參閱《使用者指示》或《使用者指南》中的「飲水機和冰塊分配機」。
 - **分配機已鎖定** - 解鎖分配機。請參閱《使用者指示》或《使用者指南》中的「飲水機和冰塊分配機」。
 - **濾水器堵塞或安裝不正確** - 更換濾水器或正確安裝。請參閱《使用者指示》或《使用者指南》中的「濾水系統」。
 - **逆滲透濾水系統已連接到您的冷水供應上** - 這可能會降低水壓。請參閱「供水要求」一節。
- 備註：如果水壓方面還是有疑問，請洽詢有執照的合格管道工。

冰塊與水	可能的原因和/或建議的解決方案
水從飲水機漏水或滴落	<p>備註：給水後，再滴幾滴水是正常的。</p> <ul style="list-style-type: none"> ■ 玻璃在分配器下的放置時間不夠長 - 釋放分配機襯墊/槓桿後，讓玻璃在分配機下保持 2 至 3 秒鐘。 ■ 新安裝的設備或最近安裝或更換的濾水器 - 水管中的空氣導致飲水機滴落。沖洗水系統，以除去供水管路中的空氣。請參閱《使用者指示》或《使用者指南》中的「飲水機和冰塊分配機」。 ■ 分配機滑道中的殘留冰正在融化 - 確保滑冰道上沒有刨花或碎屑。
水從冰箱後部漏出	<ul style="list-style-type: none"> ■ 供水管線接頭未完全拴緊 - 確保所有接頭都拴緊。請參閱「連接供水」一節。
飲水機的水不夠涼 (在某些機型上)	<p>備註：飲水機出的水會冷卻至 50°F (10°C)。</p> <ul style="list-style-type: none"> ■ 全新安裝 - 安裝後等待 24 小時，以使供水完全冷卻。 ■ 最近分配了大量的水 - 等待 24 小時使新的供水完全冷卻。 ■ 最近尚未分配水 - 第一杯水可能不涼。不要飲用分配的第一杯水。 ■ 冰箱未連接至冷水管 - 確保冰箱已連接至冷水管。請參閱「供水要求」一節。

效能資料表

濾水系統

機型 P5WB2L/P4RFBW 容量 200 加侖 (757 公升)



經 NSF International 針對 NSF/ANSI 標準 42 進行測試和認證的系統，用於減少氯的味道和氣味以及 1 級顆粒*；並符合 NSF/ANSI 標準 53，用於減少活囊腫、石棉、鉛、六氯化苯、德克沙芬、草脫淨和 2,4-D。

該系統已經按照 NSF/ANSI 標準 42 和 53 進行了減少以下所列物質的測試。根據 NSF/ANSI 標準 42 和 53 的規定，進入系統的水中指示物質的濃度降低到小於或等於離開系統的水的允許極限。

物質減少外觀效果	NSF 減少要求	平均進水	進水挑戰濃度	最大出水	最小減少 %	平均減少 %
氯味 / 異味 1 級*	減少 50% 減少 85%	2.0 mg/L 7,300,000 #/mL	2.0 mg/L ± 10% 至少 10,000 顆粒/mL	0.20 mg/L 75,000 #/mL**	97 99	97.2 99.4
減少污染物	NSF 減少要求	平均進水	進水挑戰濃度	最大出水	最小減少 %	平均減少 %
活囊腫†	99.95%	160,000/L	至少 50,000/L	54/L†	99.97	99.99
石棉	99%	87 MFL	10 ⁷ 至 10 ⁸ 纖維/L††	0.17 MFL	99	99
鉛：@ pH 6.5	0.010 mg/L	0.160 mg/L	0.15 mg/L ± 10%	0.001 mg/L	99.4	99.4
鉛：@ pH 8.5	0.010 mg/L	0.140 mg/L	0.15 mg/L ± 10%	0.005 mg/L	98.6	98.6
六氯化苯	0.0002 mg/L	0.0019 mg/L	0.002 mg/L ± 10%	0.00002 mg/L	98.9	99
德克沙芬	0.003 mg/L	0.014 mg/L	0.015 mg/L ± 10%	0.001 mg/L	93	93
草脫淨	0.003 mg/L	0.0094 mg/L	0.009 mg/L ± 10%	0.0005 mg/L	94.5	94.7
2,4 - D	0.07 mg/L	0.220 mg/L	0.210 mg/L ± 10%	0.028 mg/L	87.5	96.1

測試參數：pH = 7.5 ± 0.5，除非另外說明。水流 = 0.5 gpm (1.9 Lpm)。壓力 = 60 psig (413.7 kPa)。溫度 = 68°F 至 71.6°F (20°C 至 22°C)。額定服務容量 = 200 加侖 (757 公升)。

- 操作、維護和過濾器替代要求都必須予以執行，才能讓產品如廣告般運作。如果不遵循所有指示，可能會造成財產損失。
 - 根據您的過濾系統來使用替代過濾器，請參閱《使用者指南》中的「冰塊與水」。
- 濾水：
濾水系統樣式 1 - 訂單零件 # EDR1RXD1
濾水系統樣式 2 - 訂單零件 # EDR2RXD1
- 當控制面板上的濾水狀態從 TURN OFF (關閉) 變為 RED (紅) 燈時，建議您更換濾水器。
- 更換濾水器後，沖洗水系統。請參閱《使用者指示》或《使用者指南》中的「飲水機和冰塊分配機」或「飲水機」。
 - 這些污染物不一定會出現在您的供水系統中。在標準實驗室條件下進行測試時，實際效能可能會有所不同。

- 該產品僅適合冷水。
- 供水系統必須按照州和地方法律和法規進行安裝。
- 請勿在未經適當消毒之前，在進出系統前後使用內含不安全微生物或有品質疑慮用水。經認證可有效降低胞囊數量的系統，得用於可能含有可過濾胞囊之已消毒用水。
- 有關製造商的名稱、地址和電話號碼，請參閱「保固」一節(在《使用者指示》或《使用者指南》中)。
- 有關製造商的有限保固，請參閱「保固」一節(在《使用者指示》或《使用者指南》中)。

應用指南 / 供水參數

供水	城市或井
水壓	30 psi - 120 psi (207 kPa - 827 kPa)
水溫	33°F - 100°F (0.6°C - 37.8°C)
服務流速	0.5 gpm (1.9 Lpm) @ 60 psi

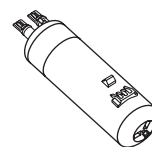

*等級 1 粒徑：>0.5 至 <1 um

**測試要求至少為 100,000 顆粒/mL 的 AC 精細測試粉塵。

†根據隱孢子蟲卵囊的用途

††長度大於 10 um 的纖維

NSF 是 NSF International 的註冊商標。

NOTES

NOTES

NOTES

NOTES

進口廠商：台灣惠而浦有限公司
地址：新北市縣民大道二段68號17樓
電話：0800-258-558
官網及 RoHS 資訊：www.whirlpool.com.tw

®/™©2022. All rights reserved.
版權所有。