



HOSHIZAKI

Service Manual

Self-Contained Crescent Cuber

Models

KM-23 IBAJ

KM-30 IBAJ, BWJ



hoshizakiamerica.com

Number: 73238
Issued: 7-23-2019
Revised: 5-17-2023

⚠ WARNING

Only qualified service technicians should install and service the appliance. To obtain the name and phone number of your local Hoshizaki Certified Service Representative, visit www.hoshizaki.com. No service should be undertaken until the technician has thoroughly read this Service Manual. Failure to service and maintain the appliance in accordance with this manual will adversely affect safety, performance, component life, and warranty coverage. Proper installation is the responsibility of the installer. Product failure or property damage due to improper installation is not covered under warranty.

Hoshizaki provides this manual primarily to assist qualified service technicians in the service of the appliance.

Should the reader have any questions or concerns which have not been satisfactorily addressed, please call, send an e-mail message, or write to the Hoshizaki Technical Support Department for assistance.

Phone: 1-800-233-1940; (770) 487-2331
Fax: 1-800-843-1056; (770) 487-3360

E-mail: techsupport@hoshizaki.com

HOSHIZAKI AMERICA, INC.

618 Highway 74 South
Peachtree City, GA 30269
Attn: Hoshizaki Technical Support Department

Web Site: www.hoshizaki.com

NOTE: To expedite assistance, all correspondence/communication **MUST** include the following information:

- Model Number _____
- Serial Number _____
- Complete and detailed explanation of the problem.

IMPORTANT

This manual should be read carefully before the appliance is serviced. Read the warnings and guidelines contained in this manual carefully as they provide essential information for the continued safe use, service, and maintenance of the appliance. Retain this manual for any further reference that may be necessary.

CONTENTS

Important Safety Information	5
I. Construction and Water/Refrigeration Circuit Diagram	7
A. Construction	7
1. Air-Cooled Models (BAJ)	7
2. Water-Cooled Models (BWJ).....	8
3. Icemaking Compartment	9
B. Water/Refrigeration Circuit Diagram.....	10
1. Air-Cooled Models (BAJ)	10
2. Water-Cooled Models (BWJ).....	11
II. Sequence of Operation and Service Diagnosis	12
A. Sequence of Operation Flow Chart.....	12
1. Operation Flow Chart	12
2. Shutdown Flow Chart	13
B. Service Diagnosis	14
1. H Control Board (P01771-02)	14
2. H+ Control Board (2B0161-01)	20
C. Control Board Check	26
1. H Control Board (P01771-02)	26
2. H+ Control Board (2B0161-01)	27
D. Bin Control Check	28
E. Float Switch Check and Cleaning	32
1. H Control Board (P01771-02)	32
2. H+ Control Board (2B0161-01)	34
F. Thermistor Check	36
G. Switches	37
H. Diagnostic Tables	38
I. Freeze-Up Check List	42
III. Controls and Adjustments	43
A. Control Board Layout	44
1. H Control Board - (P01771-02)	44
2. H+ Control Board - (2B0161-01).....	45
B. LED Lights and Audible Alarm Safeties.....	46
1. H Control Board (P01771-02)	46
2. H+ Control Board (2B0161-01)	47
C. Settings and Adjustments	48
1. H Control Board (P01771-02)	48
2. H+ Control Board (2B0161-01)	55

IV. Refrigeration Circuit and Component Service Information	60
A. Refrigeration Circuit Service Information	60
B. Component Service Information	63
C. Water Regulating Valve Adjustment (water-cooled model)	63
V. Maintenance	64
VI. Preparing the Appliance for Periods of Non-Use	65
VII. Disposal	67
VIII. Technical Information	68
A. Specification and Performance Data Sheets	68
1. KM-231BAJ	68
2. KM-301BAJ	69
3. KM-301BWJ	70
B. Wiring Diagram	71
1. H Control Board - (P01771-02)	71
2. H+ Control Board - (2B0161-01)	72

Important Safety Information

Throughout this manual, notices appear to bring your attention to situations which could result in death, serious injury, damage to the appliance, or damage to property.

⚠ WARNING Indicates a hazardous situation which could result in death or serious injury.

NOTICE Indicates a situation which could result in damage to the appliance or property.

IMPORTANT Indicates important information about the use and care of the appliance.

⚠ WARNING

The appliance should be destined only to the use for which it has been expressly conceived. Any other use should be considered improper and therefore dangerous. The manufacturer cannot be held responsible for injury or damage resulting from improper, incorrect, and unreasonable use. Failure to service and maintain the appliance in accordance with this manual will adversely affect safety, performance, component life, and warranty coverage and may result in costly water damage.

To reduce the risk of death, electric shock, serious injury, or fire, follow basic precautions including the following:

- Only qualified service technicians should install and service this appliance.
- The appliance must be installed in accordance with applicable national, state, and local codes and regulations.
- Electrical connection must be hard-wired and must meet national, state, and local electrical code requirements. Failure to meet these code requirements could result in death, electric shock, serious injury, fire, or severe damage to equipment.
- The icemaker requires an independent power supply of proper capacity. See the nameplate for electrical specifications. Failure to use an independent power supply of proper capacity can result in a tripped breaker, blown fuses, damage to existing wiring, or component failure. This could lead to heat generation or fire.
- **THE ICEMAKER MUST BE GROUNDED.** Failure to properly ground the icemaker could result in death or serious injury.
- Move the control switch to the "OFF" position and turn off the power supply before servicing. Lockout/Tagout to prevent the power supply from being turned back on inadvertently.
- To reduce the risk of electric shock, do not touch the control switch with damp hands.
- Do not make any alterations to the unit. Alterations could result in electric shock, injury, fire, or damage to the unit.
- The appliance is not intended for use by persons (including children) with reduced physical, sensory, or mental capabilities, or lack of experience and knowledge, unless they have been given supervision or instruction concerning use of the appliance by a person responsible for their safety.

⚠ WARNING, continued

- Do not make any alterations to the appliance. Alterations could result in electric shock, injury, fire, or damage to the appliance.
- The appliance is not intended for use by persons (including children) with reduced physical, sensory, or mental capabilities, or lack of experience and knowledge, unless they have been given supervision or instruction concerning use of the appliance by a person responsible for their safety.
- Children should be properly supervised around this appliance.
- Do not climb, stand, or hang on the appliance or allow children or animals to do so. Serious injury could occur or the appliance could be damaged.
- Be careful not to pinch fingers when opening and closing the door. Be careful when opening and closing the door when children are in the area.
- Do not use combustible spray or place volatile or flammable substances near the appliance. They might catch fire.
- Keep the area around the appliance clean. Dirt, dust, or insects in the appliance could cause harm to individuals or damage to the appliance.

NOTICE

- Protect the floor when moving the appliance to prevent damage to the floor.
- When making water supply or drain line repairs, follow the requirements found in the instruction manual to reduce the risk of costly water damage.
- In areas where water damage is a concern, confirm appliance is installed in a contained area with a floor drain.
- Confirm the appliance is in a location that stays above freezing. Normal operating ambient temperature must be within 45°F to 100°F (7°C to 38°C).
- If water collects in the bin and will not drain, turn off the appliance and close the water supply line shut-off valve.
- If water seeps from the base of the appliance, turn off the appliance and close the water supply line shut-off valve. Failure to do so could lead to costly water damage.
- Do not leave the appliance on during extended periods of non-use, extended absences, or in sub-freezing temperatures. To properly prepare the appliance for these occasions, follow the instructions in “VI. Preparing the Appliance for Periods of Non-Use.”
- Keep ventilation openings, in the appliance enclosure or in the built-in structure, clear of obstruction.
- Do not place more than 33 lb. (15 kg) on the top panel of the appliance.
- The ice storage bin is for ice use only. Do not store anything else in the ice storage bin.

I. Construction and Water/Refrigeration Circuit Diagram

A. Construction

1. Air-Cooled Models (BAJ)

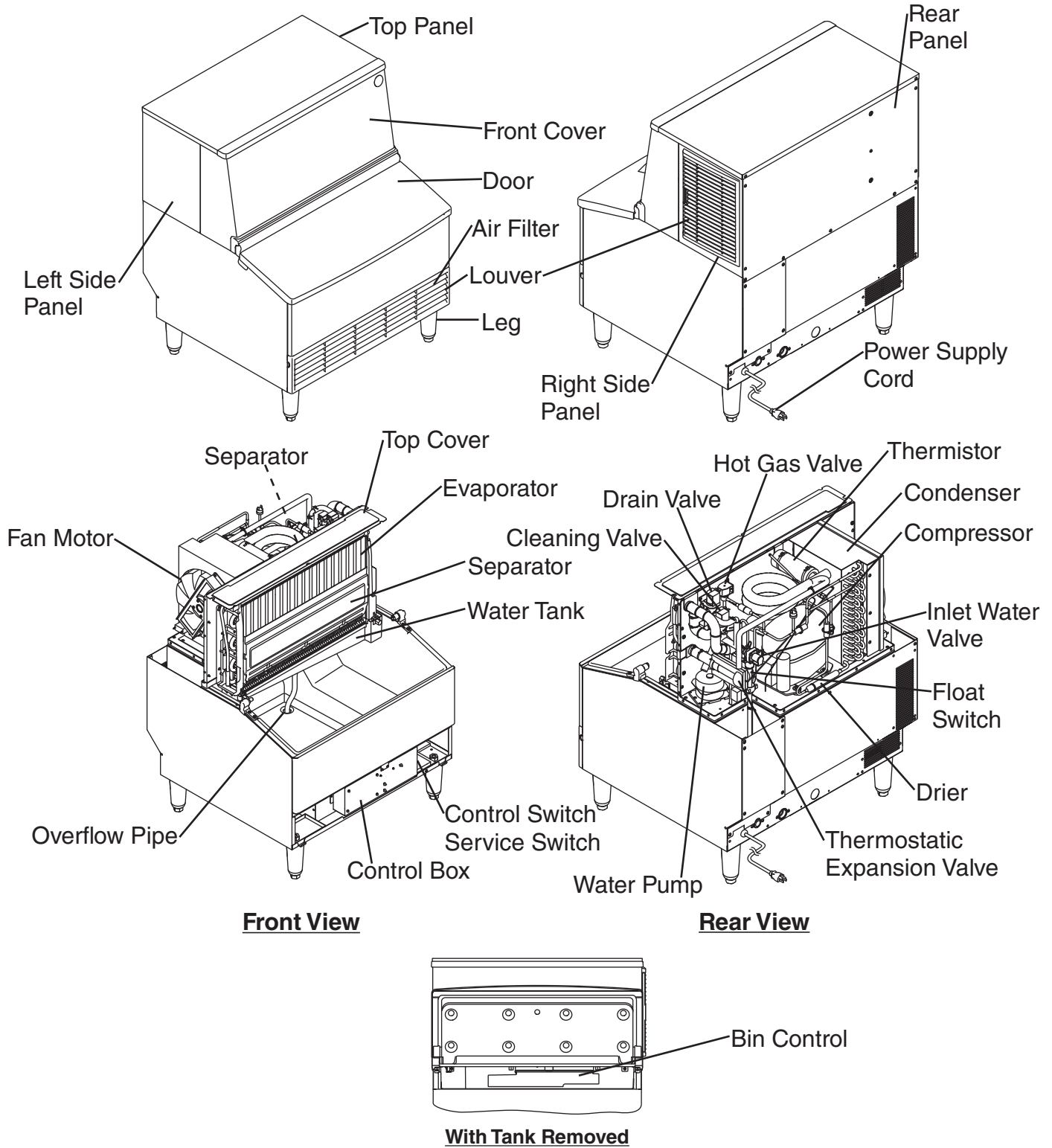

2. Water-Cooled Models (BWJ)

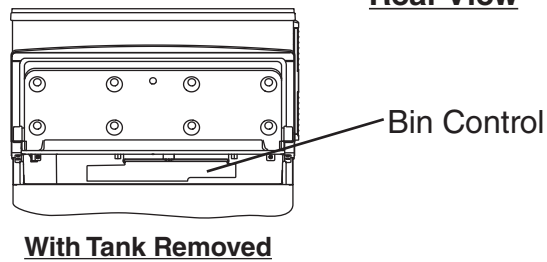
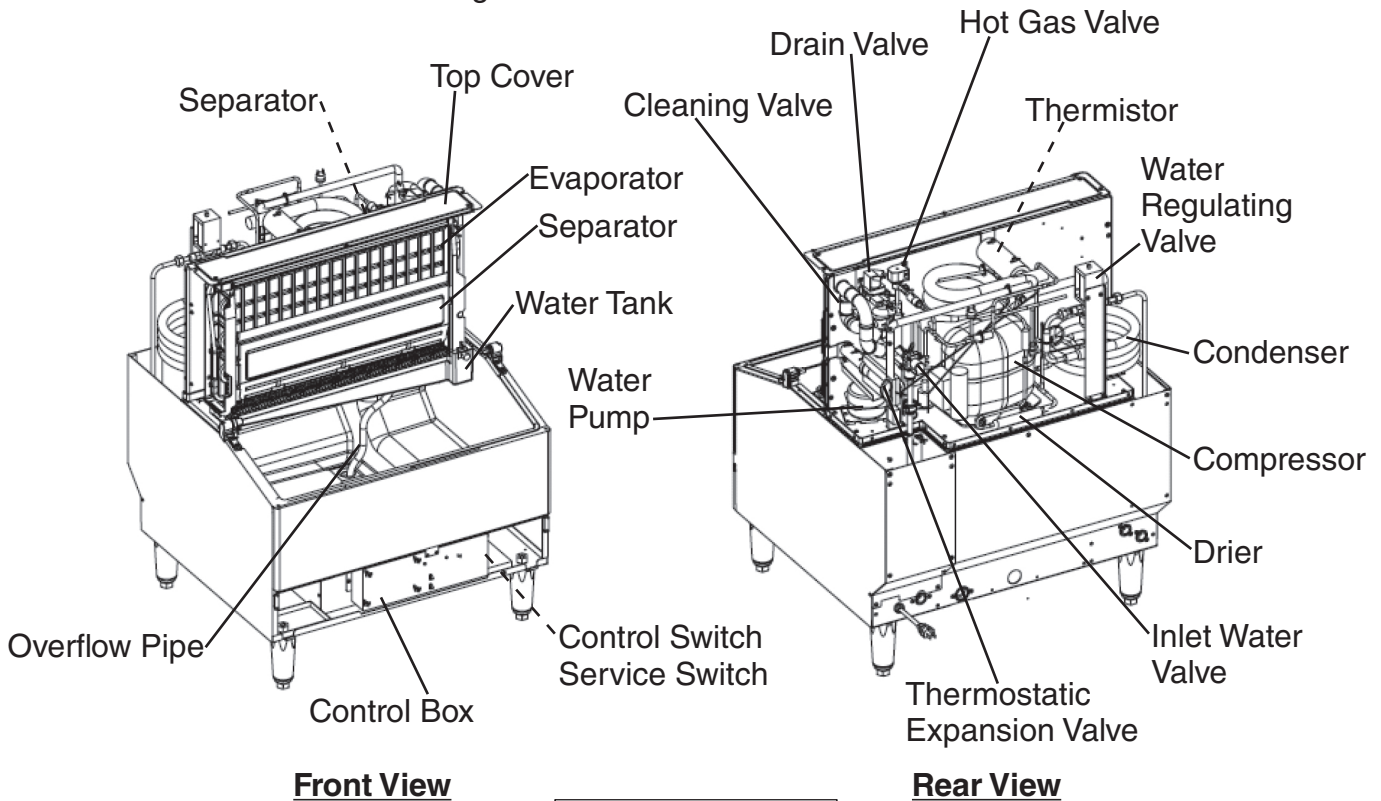
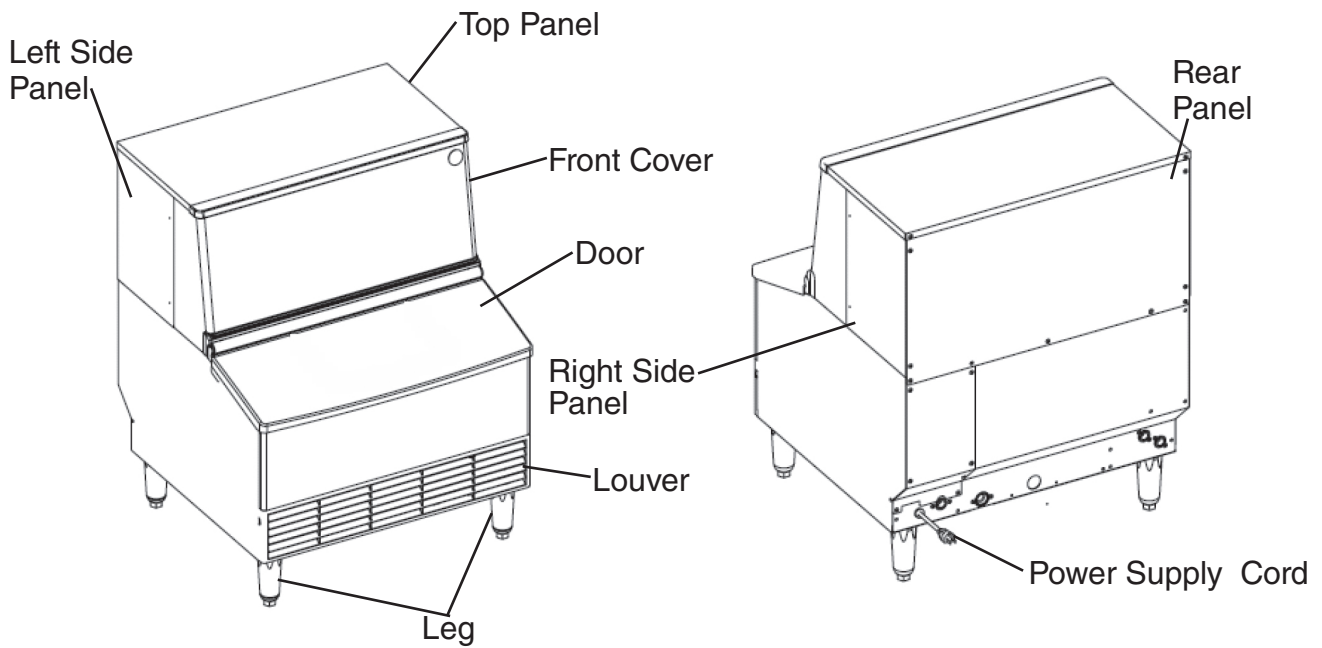

3. Icemaking Compartment

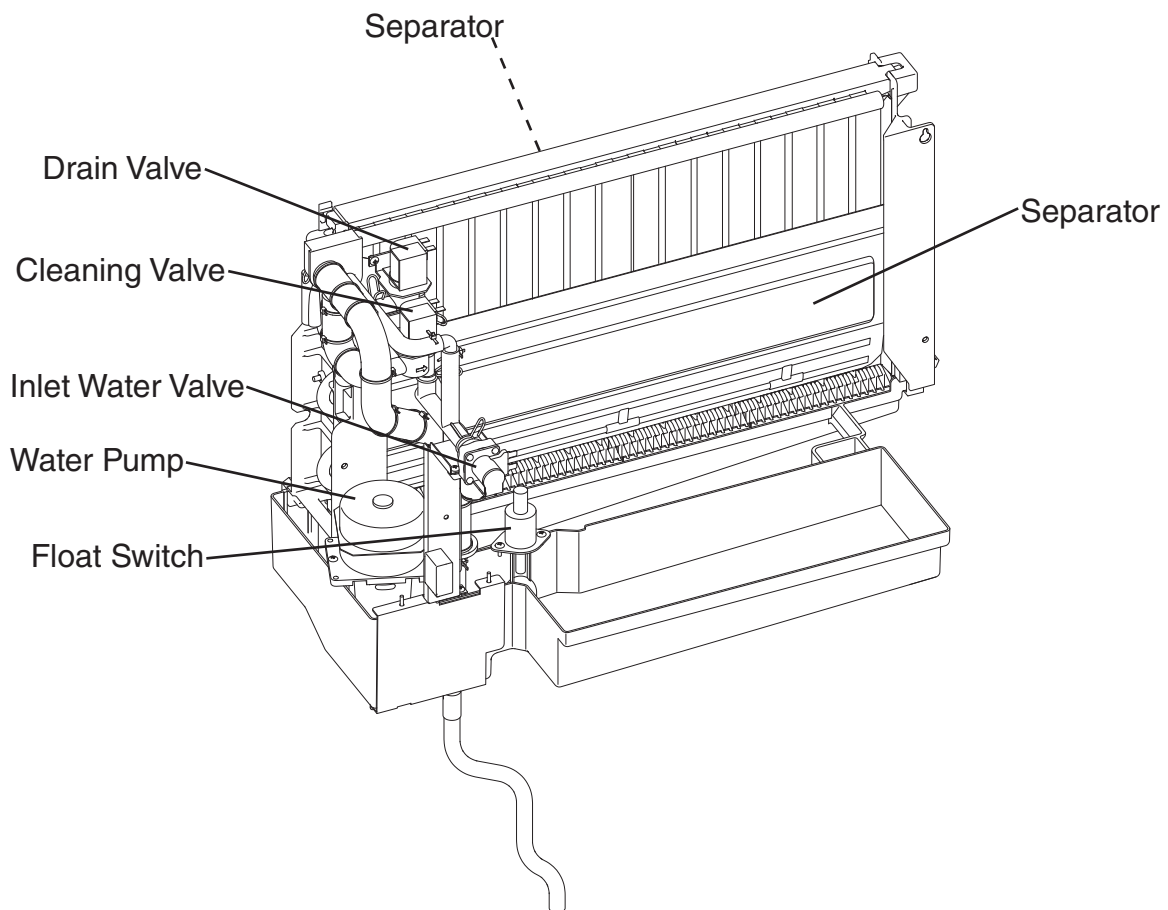
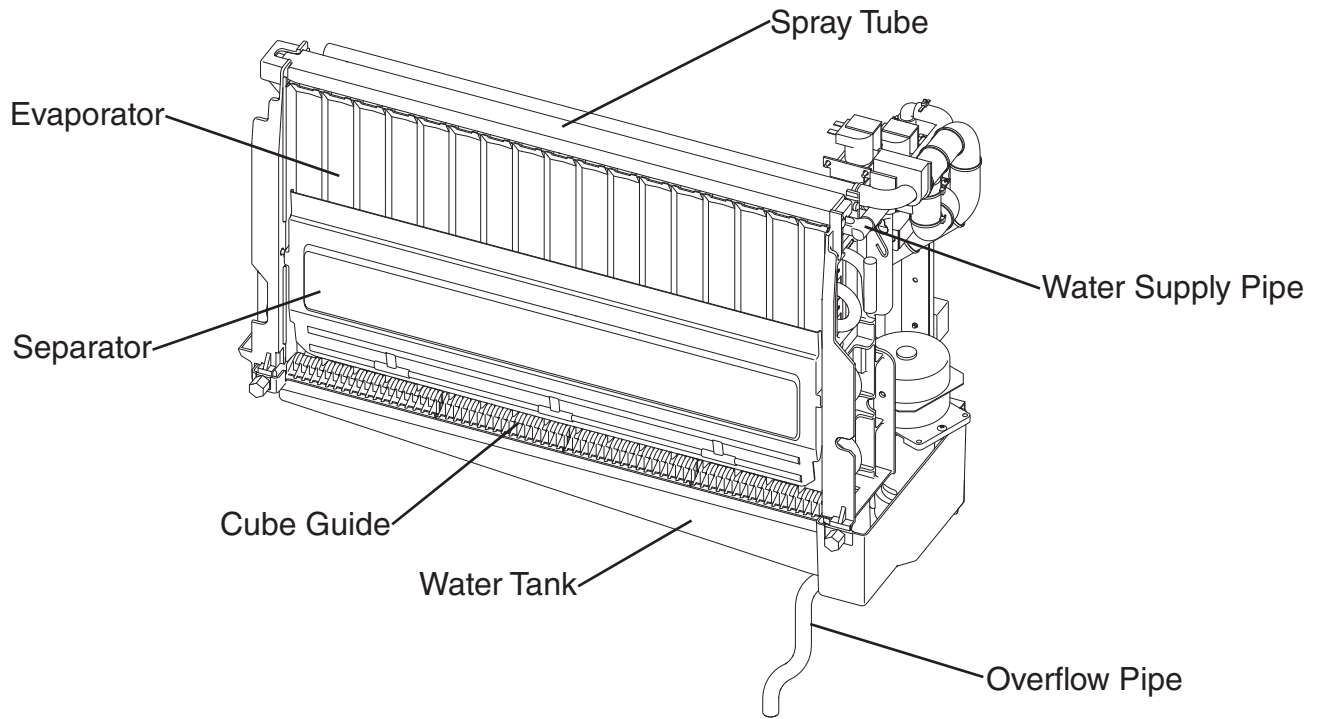

B. Water/Refrigeration Circuit Diagram

1. Air-Cooled Models (BAJ)

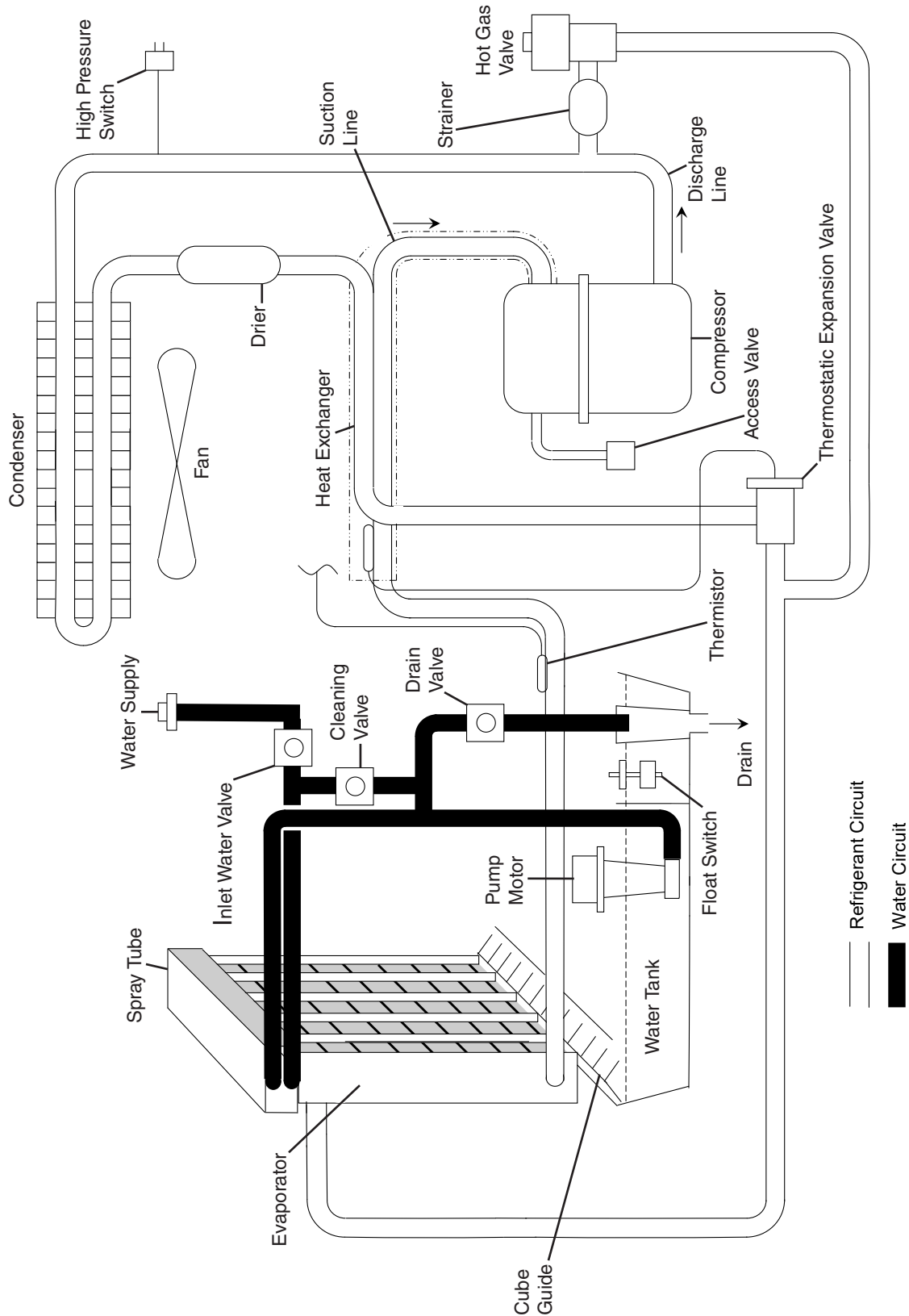

2. Water-Cooled Models (BWJ)

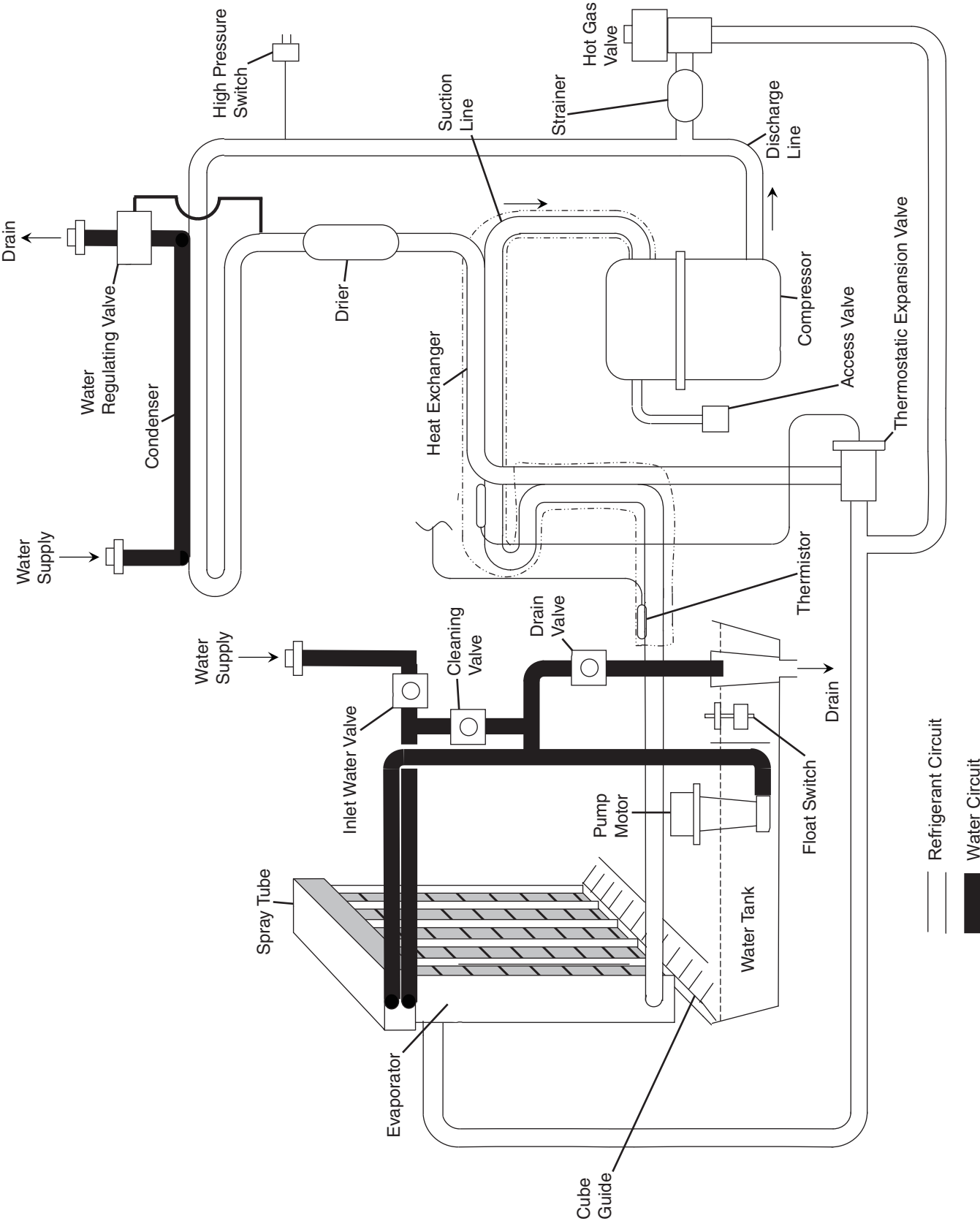

II. Sequence of Operation and Service Diagnosis

A. Sequence of Operation Flow Chart

1. Operation Flow Chart

**H Control Board P01771-02 and H+ Control Board 2B0161-01
Operation Flow Chart**

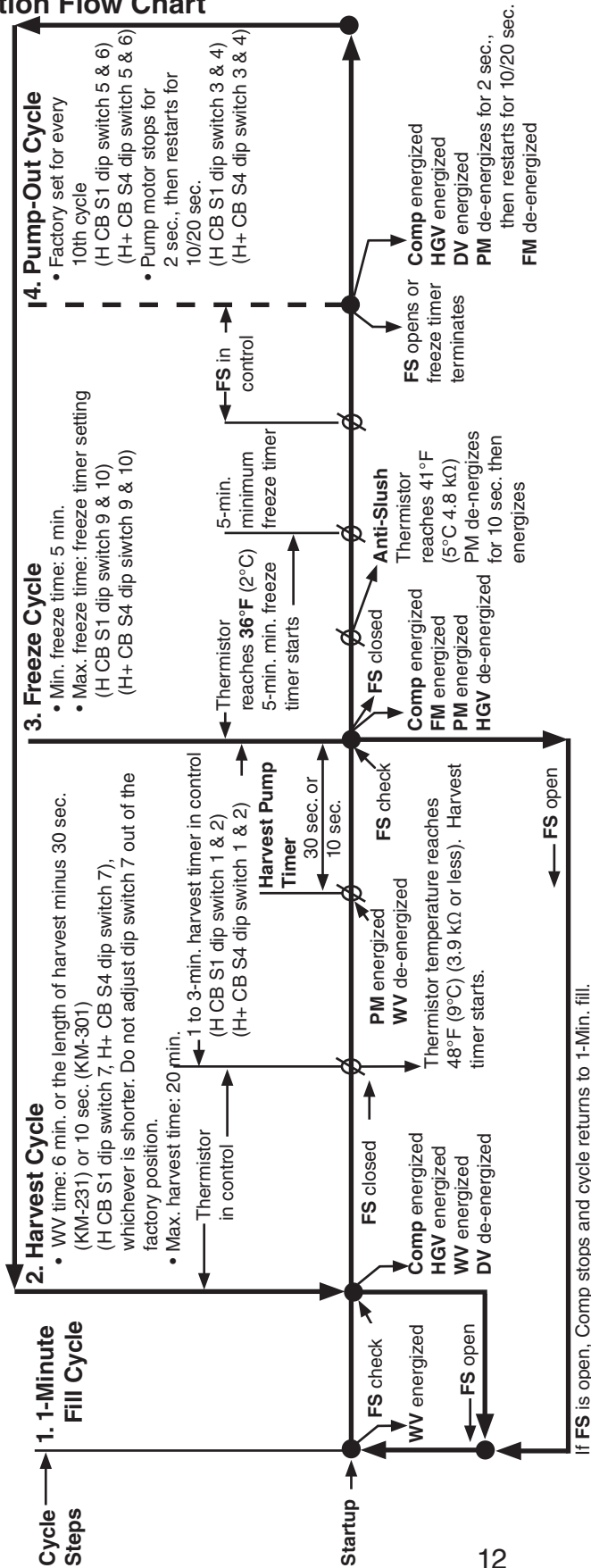

12

- Legend:**
- Comp—compressor
 - CB—control board
 - DV—drain valve
 - FM—fan motor
 - FS—float switch
 - HGV—hot gas valve
 - PM—pump motor
 - WV—inlet water valve

Components Energized when the Control Switch is in the "WASH" Position

The "WASH" position on the control switch is used when cleaning and sanitizing the unit. When in the "WASH" position, power is supplied to the pump motor. With the cleaning valve closed, the cleaner and sanitizer flow over the outside of the evaporator plate assembly. With the cleaning valve open, the cleaner and sanitizer flow over both the outside and the inside of the evaporator plate assembly.

Note: Close the cleaning valve after cleaning and sanitizing are complete, otherwise the icemaker will not restart when the control switch is placed in the "ICE" position.

2. Shutdown Flow Chart

H Control Board P01771-02 and H+ Control Board 2B0161-01

Shutdown Flow Chart

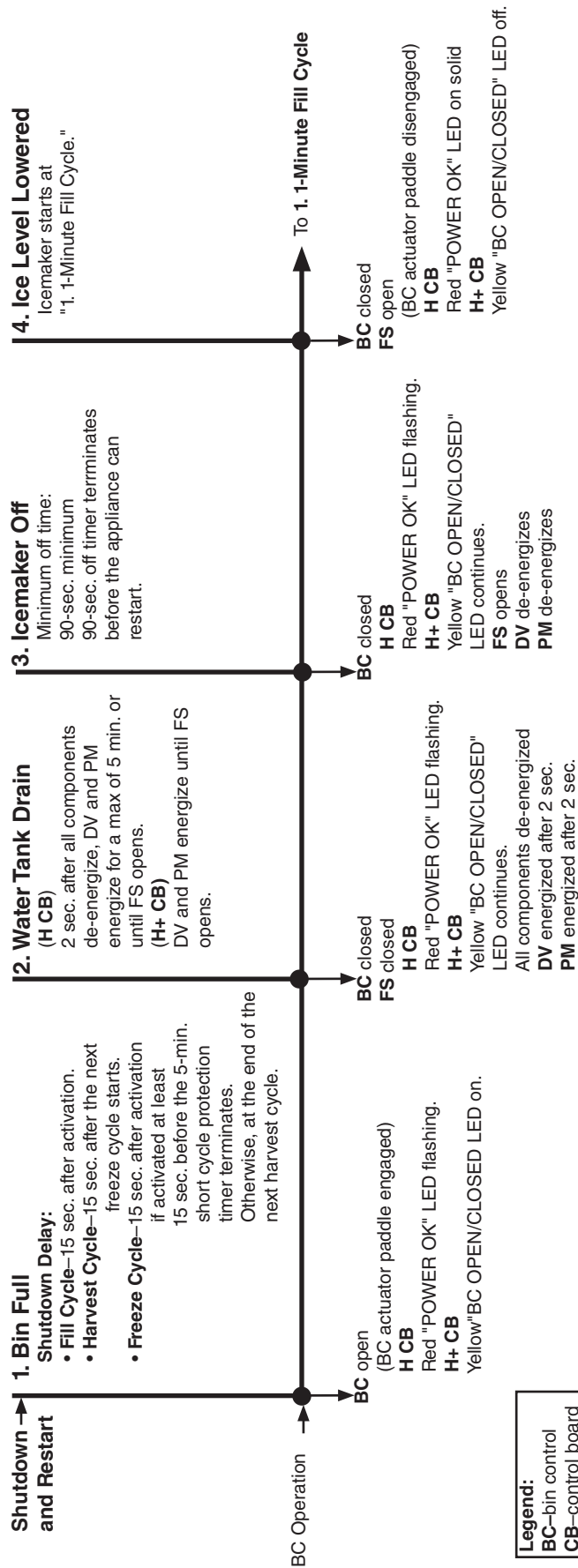

Legend:
BC—bin control
CB—control board
DV—drain valve
FS—float switch

B. Service Diagnosis

1. H Control Board (P01771-02)

Model	Auxiliary Code Break
KM-231BAJ	L12797H and earlier
KM-301BAJ	L13727K and earlier
KM-301BWJ	L10215H and earlier

WARNING

- The appliance should be diagnosed and repaired only by qualified service personnel to reduce the risk of death, electric shock, serious injury, or fire.
- Risk of electric shock. Control switch in “OFF” position does not de-energize all loads Use extreme caution and exercise safe electrical practices.
- Moving parts (e.g., fan blade) can crush and cut. Keep hands clear.
- **CHOKING HAZARD:** Ensure all components, fasteners, and thumbscrews are securely in place after the appliance is serviced. Make sure that none have fallen into the dispenser unit/ice storage bin.
- Make sure all food zones in the appliance and dispenser unit/ice storage bin are clean after service.

The diagnostic procedure is a sequence check that allows you to diagnose the electrical system and components. Before proceeding, check for correct installation, proper voltage per nameplate, and adequate water supply. Check CB using the steps in “II.C.1. H Control Board (P01771-02).” Check dip switch settings to assure that S1 dip switches 3, 4, 7, 8, 9, & 10 and S2 dip switches 1 through 6 are in the factory default position. S1 dip switch 1, 2, 5, and 6 are cleaning adjustments and the settings are flexible. For factory default settings, see “III.C.1.a) Default Dip Switch Settings.”

Note: When checking high voltage (115VAC), always choose a white (W) neutral wire to establish a good neutral connection.

- 1) Remove the louver. Move the control switch to the “OFF” position, then unplug the appliance from the electrical outlet. Clear any ice from BC.
- 2) Check that the 115VAC 5A fuse is good.

a) Sequence and Component Diagnosis

- 3) **Power On:** Plug the appliance into the electrical outlet. Move the control switch to the “ICE” position. Check that the 5A 250V fuse is good. A 5-sec. delay occurs. CB red “POWER OK” LED turns on.

Note: • CB red “POWER OK” LED remains on unless the 10.5VAC power supply is interrupted (K7 connector).

- Check CB using the steps in “II.C.1. H Control Board (P01771-02).”
- Confirm CB red “POWER OK” LED is on. If CB red “POWER OK” LED is flashing (indicating a full bin), check BC. Move ice away from BC actuator paddle. If CB red “POWER OK” LED continues to flash, see “II.D.1a. Bin Control Check - H Control Board (P01771-02).”

- a) **Power On Diagnosis:** If CB red “POWER OK” LED is off, confirm 5A fuse is good. Check for 115VAC at control switch #2 (R) to neutral (W) then at control switch #1 (P) to neutral (W). If 115VAC is present on #2 (R) and not on #1 (P), replace control switch. If 115VAC is present on control switch #1 (P), check for 115VAC at HPS (P) to neutral (W) then HPS (BK) to neutral (W). If 115VAC is present at HPS (P) and not at HPS (BK), HPS is open. See HPS Diagnosis below. If 115VAC is present at HPS (BK), check for 10.5VAC at CB K7 #1 red wire to CB K7 #2 red wire. If 10.5VAC is not present, check CT continuity. If open, replace CT.

- b) **HPS Diagnosis:** Check that the condenser coil is not clogged or restricted. Let refrigeration circuit pressures equalize. If HPS does not reset and pressures are equalized, replace HPS. If pressures are not equalized, reclaim refrigerant and diagnose refrigeration circuit restriction. Check that there are no restrictions in the refrigeration circuit.

Harvest Cycle: HGV, strainer, or check valve.

Freeze Cycle: FM, TXV, WRV, strainer, and drier.

Confirm that the location meets installation requirements:

- The appliance is not intended for outdoor use. Normal operating ambient temperature should be within 45°F to 100°F (7°C to 38°C).
 - Allow 2” (5 cm) clearance on the right side and 5/8” (15 mm) clearance at the top for proper air circulation and ease of maintenance and/or service should they be required.
 - The appliance should not be located in a corrosive environment.
- 4) **1-Min. Fill Cycle – LED 8 is on.** WV energizes. After 1 min., CB checks for a closed FS. If FS is closed, the harvest cycle begins. If harvest cycle begins (Comp, HGV, energized), continue to step 5a. If FS is open, WV remains energized until FS closes (low water safety protection during initial start up and at the end of each harvest). **Diagnosis:** Check that water enters the water tank. If not, check that the water supply line shut-off valve is open and screens or external filters are clear. Check for 115VAC at CB K5 #4 (O) to neutral (W). If 115VAC is not present, replace CB. If 115VAC is present, and WV does not energize, check for 115VAC at WV. If 115VAC is present, check coil continuity. If open, replace WV. If the water tank fills, but the appliance fails to start harvest (Comp energized), check for open FS. See “II.E.1.a) Float Switch Check.” If FS is closed and CB fails to start the harvest cycle after 1 min., replace CB.

5a) **Initial Harvest Cycle – LEDs 5, 6, and 8 are on.** WV continues. Comp and HGV energize. CB monitors the warming of the evaporator via the thermistor located on the suction line. When the thermistor reaches 48°F (9°C), CB reads 3.9 kΩ from the thermistor and turns harvest termination over to the harvest timer (S1 dip switch 1 & 2 and S2 dip switch 4). WV is energized during harvest for a maximum of 6 min. or the length of harvest minus HPT setting (S1 dip switch 7 & 8), whichever is shorter. See step 5b below.

a) **Comp Diagnosis:** Check that evaporator is warming. If not, confirm that Comp energizes. If not, check for 115VAC at CB K3 #2 (V) to neutral (W). If 115VAC is not present, check for 115VAC at CB K3 #1 (P) to neutral (W). If 115VAC is present at #1 (P) and not at #2 (V), replace CB. If 115VAC is present, check for 115VAC at CR solenoid. If 115VAC is present, confirm contacts are closed. If not, replace CR. If CR contacts are closed, check Comp external overload, Comp start capacitor, Comp start relay, and Comp motor winding.

b) **HGV Diagnosis:** If Comp is energized and evaporator is not warming, check that HGV energizes and opens. Check for 115VAC at CB K5 #2 (V) to neutral (W). If 115VAC is not present and LED 6 is on, replace CB. If 115VAC is present, check for 115VAC at HGV coil and check HGV coil continuity. Replace as needed.

c) **WRV Diagnosis:** Confirm WRV is not leaking by. If WRV is leaking by, confirm HGV is open. Next, check for proper refrigerant pressures. If refrigerant pressures are correct, adjust or replace WRV. See “IV.C. Water Regulating Valve Adjustment (water-cooled models).”

5b) **Harvest Pump Time (Harvest Assist) – LEDs 5, 6, and 7 are on.** When the thermistor reaches 48°F (9°C), CB reads 3.9 kΩ from the thermistor and turns harvest termination over to the harvest timer (S1 dip switch 1 & 2 and S2 dip switch 4). When WV de-energizes, LED 8 turns off and LED 7 turns on. PM energizes. Comp and HGV continue.

Diagnosis: Place a thermometer on the suction line next to the thermistor. Has it warmed to 48°F (9°C) or warmer? Confirm thermistor status. See “II.F. Thermistor Check.” If the thermistor reading is in proper range, dip switch 7 is on, and PM does not energize before harvest terminates, replace CB. If WV continues, check for 115VAC at CB K5 #4 (O). If 115VAC is present, and LED 8 is off, replace CB. If LED 7 is on and PM is not energized, check for 115VAC at CB K5 #3 (DBU). If 115VAC is not present, replace CB. If 115VAC is present and PM is not energized, check for 115VAC at the control switch terminal #4 (DBU) and #5 (BK). If 115VAC is present, replace control switch. If contacts are closed and 115VAC is present between control switch terminal #5 (BK) and neutral (W), check PM capacitor and motor winding continuity.

5c) **Initial Harvest Cycle Termination Diagnosis:** When the thermistor reaches 48°F (9°C), CB reads 3.9 kΩ from the thermistor and turns harvest termination over to the harvest timer (S1 dip switch 1 & 2 and S2 dip switch 4). Check discharge line temperature. For a thermistor check, see “II.F. Thermistor Check.” If 1-min. fill cycle starts after harvest timer terminates, check that FS is clean and operating properly, see “II.E.1.b) Float Switch Cleaning.” If FS is closed, CB proceeds to the next cycle. If not, replace CB.

Note: The minimum total time allowed by CB for a complete harvest cycle is based on S2 dip switch 4. Maximum harvest time allowed is 20 min.

NOTICE! S1 dip switch 7 must remain on. Otherwise, PM will not energize during the last seconds of harvest.

6) **Freeze Cycle – LED 5 and 7 are on.** Comp and PM continue. FM energizes. HGV de-energizes. Appliance is held in freeze by a temperature/time short cycle protection cycle. Thermistor reaches 36°F (2°C), then the 5-min. short cycle protection timer starts. After the 5-min. short cycle protection timer terminates and FS opens, freeze cycle terminates.

Anti-Slush Control: When anti-slush control is enabled (S2 dip switch 5 “ON”), PM de-energizes when thermistor reaches 50°F (10°C) (3.9kΩ) for 10 sec. then, energizes for 50 sec. repeatedly. When thermistor reaches 34°F (1°C) (5.9kΩ) PM de-energizes for 10 sec., energizes for 50 sec., de-energizes for 10 sec., again, then energizes the remainder of the freeze cycle.

- a) **Freeze Cycle Diagnosis:** Confirm Comp and PM continue. Confirm that FM energizes. Confirm WRV opens. Next, confirm HGV de-energizes. During the first 5 min. of freeze, confirm evaporator is cooling. If not, confirm WV de-energized (not leaking by), HGV de-energized (not bypassing), FM energizes, TXV operates correctly, WRV opens, Comp is efficient, and refrigerant charge is correct. See “VIII.A. Specification and Performance Data Sheets.”
- b) **Comp Diagnosis:** If Comp de-energizes once freeze begins, check that appliance has not shut off on HPS (CB “POWER OK” LED off). If so, check “3)b) HPS Diagnosis” above. If CB “POWER OK” LED is on, check for 115VAC at CB K3 #2 (V) to neutral (W). If 115VAC is not present and LED 5 is on, replace CB. If 115VAC is present, check for 115VAC at CR coil. If 115VAC is present, check CR coil and contact continuity. Replace as needed. If CR is okay, check Comp start relay and start capacitor. Next, check Comp motor winding continuity. If Comp is energized but evaporator is not cooling, check for an inefficient Comp. See “VIII.A. Specification and Performance Data Sheets.”
- c) **WV and HGV Diagnosis:** If WV is energized, check for 115VAC at CB K5 #4 (O) to neutral (W). If 115VAC is present after PM energizes in harvest cycle, replace CB. If 115VAC is not present, replace WV (bypassing). If HGV did not de-energize at the end of harvest, check for 115VAC at CB K5 #2 (V) to neutral (W). If 115VAC is present and LED 6 is off, replace CB. If 115VAC is not present, replace HGV (bypassing).
- d) **PM Diagnosis:** Confirm water is flowing over evaporator from PM and not WV. If PM de-energizes once freeze begins, check for 115VAC at CB K5 #3 (DBU) to neutral (W). If 115VAC is not present, replace CB. If 115VAC is present and PM is de-energized, check for 115VAC at control switch #4 (DBU) to neutral (W). If 115VAC is present at CB K5 #3 (DBU) and not at control switch #4 (DBU), check control switch continuity between #5 (BK) and #4 (DBU). Replace as needed. If 115VAC is present at control switch #4 (DBU) to neutral (W), check PM capacitor and motor winding continuity.
- e) **FM Diagnosis:** If FM does not energize, check for 115VAC at CB K5 #1 (BK) to neutral (W). If 115VAC is not present, replace CB. If 115VAC is present: For FM, check capacitor, motor winding, and blade for binding.

- f) **Refrigerant Pressures and TXV Diagnosis:** If evaporator is still not cooling, check refrigerant pressures. See “VIII.A. Specification and Performance Data Sheets.” Next, check TXV for proper operation. Remove TXV bulb and hold it in your hand, refrigerant low-side pressure should rise, place TXV bulb in ice water, refrigerant low-side pressure should drop. A 10 to 15 pound pressure swing between warm and cold conditions indicate a good TXV. If a 10 to 15 pound swing is not present, replace TXV.
- g) **WRV Diagnosis:** WRV is factory set and generally no adjustment is required. If WRV fails to open in freeze, check for proper refrigerant pressures. See “VIII.A. Specification and Performance Data Sheets.” If refrigerant pressures are correct and WRV does not open, adjust or replace as needed. See “IV.C. Water Regulating Valve Adjustment (water-cooled models).”
- h) **Freeze Termination Diagnosis:** After thermistor has reached 36°F (2°C) and the 5 min. short cycle protection timer has terminated, disconnect the FS connector. 15 sec. later appliance should switch out of the freeze cycle (15 second delay after FS opens before terminating the freeze cycle). If appliance remains in freeze longer than 15 sec. after FS removed, replace CB. If appliance switches with FS removed but would previously not switch out of freeze with FS connected (long freeze - 3 beep alarm), see “II.E.1.a) Float Switch Check.”

Note: Normal freeze cycle will last 20 to 40 min. depending on model and conditions. Cycle times and pressures should follow performance data provided in this manual. See “VIII.A. Specification and Performance Data Sheets.”

- i) **Short Freeze Cycle Diagnosis:** Confirm water tank fills and overflows during 1 min. fill and harvest cycles. If not, check water supply filters, shut-off valve, WV screen. If water tank empties before 5 min. timer terminates and freeze cycle is short, check that DV is not leaking by or energized (water flowing through DV). If DV is leaking by, remove and clean DV, replace as needed. If water tank is full, see “II.E.1.a) Float Switch Check.” for erratic operating FS.

7) **Pump-Out Cycle – LEDs 4, 5, 6, and 7 are on (10/20 second pump-out).** Timing of the first pump-out is determined by S1 dip switches 5 and 6. See the table below.

Control Board Settings			
S1 Dip Switch Setting		Pump-Out Frequency	Control Board
No. 5	No. 6		
OFF	OFF	Every cycle	After 2nd freeze cycle
ON	ON	Every 10 cycles	After 11th freeze cycle

Comp continues, HGV energizes. FM de-energizes. PM stops for 2 sec., then restarts for 10/20 sec. depending on pump-out timer (S1 dip switch 3 & 4) setting. When the pump-out timer terminates, pump-out is complete. The pump-out frequency control (S1 dip switch 5 and 6) is factory set, and generally no adjustment is required. However, the pump-out frequency control can be set to have a pump-out occur every 10 cycles or every cycle. For details, see “III.C.1.d) Pump-Out Frequency Control (S1 dip switch 5).”

Pump-Out Diagnosis: In the freeze cycle before pump-out (see table above), after 5 min. of freeze disconnect FS connector. Check that CB LEDs 4, 5, 6, and 7 are on, PM stops, then restarts, DV energizes, and water is flowing down the drain through DV. If not, continue to steps below.

a) **CB Diagnosis:** Confirm FM de-energizes. If FM is energized with LEDs 4, 5, 6, and 7 on, replace CB. If PM does not stop and restart and DV does not energize, check that CB LEDs 4, 5, 6, and 7 are on. If not, replace CB. If LEDs 4, 5, 6, and 7 are on and PM is not energized, check for 115VAC at CB K5 #3 (DBU) to neutral (W). If 115VAC is not present, replace CB. If 115VAC is present at CB K5 #3 (DBU) and PM is not energized, continue to “b) **PM Diagnosis:**” below. If PM is energized and DV is not energized, check for 115VAC at CB K5 #6 (GY) to neutral (W). If LED 4 is on and 115VAC is not present at CB K5 #6 (GY), replace CB.

b) **PM Diagnosis:** Check for 115VAC CB K5 #3 (DBU) to neutral (W). If 115VAC is not present, see “b) **CB Diagnosis**” above. Next, check for 115VAC at control switch #4 (DBU) to neutral (W). If 115VAC is not present, confirm 115VAC at control switch #5 (BK) to neutral (W). If 115VAC is present at control switch #5 (BK) and not at control switch #4 (DBU), replace control switch. If 115VAC is present at control switch #4 (DBU) and PM is de-energized, check PM capacitor, motor winding, wiring connections, and impeller for binding.

e) **DV Diagnosis:** Check for 115VAC at CB K5 #6 (GY) to neutral (W). If 115VAC is not present, see “b) **CB Diagnosis:**” above. If 115VAC is present at CB K5 #6 (GY) and DV is de-energized, check DV coil continuity, make sure the drain line is not clogged and that DV is clean and operating properly.

- 8) **Normal Harvest Cycle** – Same as the initial harvest cycle. Return to step 5a) above.
Note: Appliance continues to cycle until BC is satisfied or power is switched off.
The appliance always restarts at the 1-min. fill cycle.

b) Shutdown Diagnosis

- 1) See “II.D.1a. Bin Control Check - H Control Board (P01771-02).”

Legend: **BC**–bin control; **CB**–control board; **Comp**–compressor; **CR**–compressor relay; **DV**–drain valve; **FM**–fan motor; **FS**–float switch; **HGV**–hot gas valve; **HPS**–high-pressure switch; **PM**–pump motor; **TXV**–thermostatic expansion valve; **WRV**–water regulating Valve; **WV**–inlet water valve

2. H+ Control Board (2B0161-01)

Model	Auxiliary Code Break
KM-231BAJ	L22798M and later
KM-301BAJ	M03728A and later
KM-301BWJ	M00216H and later

WARNING

- The appliance should be diagnosed and repaired only by qualified service personnel to reduce the risk of death, electric shock, serious injury, or fire.
- Risk of electric shock. Control switch in "OFF" position does not de-energize all loads Use extreme caution and exercise safe electrical practices.
- Moving parts (e.g., fan blade) can crush and cut. Keep hands clear.
- Before servicing the appliance, move the control switch to the "OFF" position and unplug the appliance.
- **CHOKING HAZARD:** Ensure all components, fasteners, and thumbscrews are securely in place after the appliance is serviced. Make sure that none have fallen into the dispenser unit/ice storage bin.
- Make sure all food zones in the appliance and dispenser unit/ice storage bin are clean after service.

The diagnostic procedure is a sequence check that allows you to diagnose the electrical system and components. Before proceeding, check for correct installation, proper voltage per nameplate, and adequate water supply. Check CB using the steps in "II.C.2. H+ Control Board (2B0161-01)." Check dip switch settings to assure that S4 dip switches and S5 dip switches 1 through 5 are in the factory default position. S4 dip switch 1 through 5, are cleaning adjustments and the settings are flexible. For factory default settings, see "III.C.2.a) Default Dip Switch Settings."

Note: When checking high voltage (115VAC), always choose a white (W) neutral wire to establish a good neutral connection.

- 1) Remove the louver. Move the control switch to the "OFF" position, then unplug the appliance from the electrical outlet. Clear any ice from BC.
- 2) Check that the 5A fuse is good.

a) Sequence and Component Diagnosis

- 3) **Power On:** Plug the appliance into the electrical outlet, then move the control switch to the "ICE" position. A 5-sec. delay occurs. CB red "POWER OK" LED turns on. If CB yellow "BC OPEN/CLOSED" LED is on (indicating a full bin), move ice away from BC.

Note: • CB red "POWER OK" LED remains on unless the 10.5VAC power supply is interrupted (K2 connector).

- Check CB using the steps in "II.C.2. H+ Control Board (2B0161-01)" or BC using steps in "II.D.1b. Bin Control Check - H+ Control Board (2B0161-01)."

- a) **Power On Diagnosis:** If CB red "POWER OK" LED is off, confirm 5A fuse is good. Check for 115VAC at control switch #2 (BR) to neutral (W), then at control switch #1 (P) to neutral (W). If 115VAC is present on #2 (BR) and not on #1 (P), replace control switch. If 115VAC is present on control switch #1 (P), check for 115VAC at HPS (P) to neutral (W), then HPS (BK) to neutral (W). If 115VAC is present at HPS (P) and not at HPS (BK), HPS is open. See HPS Diagnosis below. If 115VAC is present at HPS (BK), check for 10.5VAC at CB K2 #1 red wire to CB K2 #2 red wire. If 10.5VAC is not present, check CT continuity. If open, replace CT.

- b) **HPS Diagnosis:** Check that the condenser coil is not clogged or restricted. Let refrigeration circuit pressures equalize. If HPS does not reset and pressures are equalized, replace HPS. If pressures are not equalized, reclaim refrigerant and diagnose refrigeration circuit restriction. Check that there are no restrictions in the refrigeration circuit.

Harvest Cycle: HGV, strainer, or check valve.

Freeze Cycle: FM, TXV, WRV, strainer, check valve, or drier.

Confirm that the location meets installation requirements:

- The appliance is not intended for outdoor use. Normal operating ambient temperature should be within 45°F to 100°F (7°C to 38°C).
 - Allow 2" (5 cm) clearance on the right side and 5/8" (15 mm) clearance at the top for proper air circulation and ease of maintenance and/or service should they be required.
 - The appliance should not be located in a corrosive environment.
- 4) **1-Min. Fill Cycle – LED 4 is on.** WV energizes. After 1 min., CB checks for a closed FS. If FS is closed, the harvest cycle begins. If harvest cycle begins (Comp, HGV energized), continue to step 5a. If FS is open, fill cycle continues until FS closes (low water safety protection during initial start up and at the end of each harvest). **Diagnosis:** Check that water enters the water tank. If not, check that the water supply line shut-off valve is open and screens or external filters are clear. Check for 115VAC at CB K1 #6 (O) to neutral (W). If 115VAC is not present, replace CB. If 115VAC is present, and WV does not energize, check for 115VAC at WV. If 115VAC is present, check coil continuity. If open, replace WV. If the water tank fills, but the appliance fails to start harvest (Comp energized), check for open FS. See "II.E.2.a) Float Switch Check." If FS is closed and CB fails to start the harvest cycle after 1 min., replace CB.

5a) **Initial Harvest Cycle – LEDs 1 and 4 are on.** WV continues. Comp and HGV energize. CB monitors the warming of the evaporator via the thermistor located on the suction line. When the thermistor reaches 48°F (9°C), CB reads 3.9 kΩ from the thermistor and turns harvest termination over to the harvest timer (S4 dip switch 1 & 2 and S5 dip switch 4). WV is energized during harvest for a maximum of 6 min. or the length of harvest minus HPT setting (S4 dip switch 6), whichever is shorter. See step 5b below.

a) **Comp Diagnosis:** Check that evaporator is warming. If not, confirm that Comp energizes. If not, check for 115VAC at CB K1 #9 (V) to neutral (W). If 115VAC is not present, check for 115VAC at CB K1 #10 (P) to neutral (W). If 115VAC is present at #10 (P) and not at #9 (V), replace CB. If 115VAC is present, check for 115VAC at CR solenoid. If 115VAC is present, confirm contacts are closed. If not, replace CR. If CR contacts are closed, check Comp external overload, Comp start capacitor (if applicable), Comp start relay, and Comp motor winding.

b) **HGV Diagnosis:** If Comp is energized and evaporator is not warming, check that HGV energizes and opens. Check for 115VAC at CB K1 #2 (P) to neutral (W). If 115VAC is present on #1 (V) and not at #2 (P), replace CB. If 115VAC is present at #2 (P), check for 115VAC at HGV coil and check HGV coil continuity. Replace as needed.

c) **WRV Diagnosis:** Confirm WRV is not leaking by. If WRV is leaking by, confirm HGV is open. Next, check for proper refrigerant pressures. If refrigerant pressures are correct, adjust or replace WRV. See "IV.C. Water Regulating Valve Adjustment (water-cooled models)."

5b) **Harvest Pump Time (Harvest Assist) – LEDs 1 and 3 are on.** When the thermistor reaches 48°F (9°C), CB reads 3.9 kΩ from the thermistor and turns harvest termination over to the harvest timer (S4 dip switch 1 & 2 and S5 dip switch 4). When WV de-energizes, LED 4 turns off and LED 3 turns on. PM energizes. Comp, and HGV continue.

Diagnosis: Place a thermometer on the suction line next to the thermistor. Has it warmed to 48°F (9°C) or warmer? Confirm thermistor status. See "II.F. Thermistor Check." If the thermistor reading is in proper range, dip switch 7 is on, and PM does not energize before harvest terminates, replace CB. If WV continues, check for 115VAC at CB K1 #6 (O). If 115VAC is present, and LED 4 is off, replace CB. If LED 3 is on and PM is not energized, check for 115VAC at CB K1 #4 (DBU) to neutral (W). If 115VAC is not present, replace CB. If 115VAC is present and PM is not energized, check PM capacitor and motor winding continuity.

5c) **Initial Harvest Cycle Termination Diagnosis:** When the thermistor reaches 48°F (9°C), CB reads 3.9 kΩ from the thermistor and turns harvest termination over to the harvest timer (S4 dip switch 1 & 2 and S5 dip switch 4). Check discharge line temperature. For a thermistor check, see "II.F. Thermistor Check." If 1-min. fill cycle starts after harvest timer terminates, check that FS is clean and operating properly, see "II.E.2.b) Float Switch Cleaning." If FS is closed, CB proceeds to the next cycle. If not, replace CB.

Note: The minimum total time allowed by CB for a complete harvest cycle is based on S5 dip switch 4. Maximum harvest time allowed is 20 min.

NOTICE! S4 dip switch 7 must remain on. Otherwise, PM will not energize during the last seconds of harvest.

6) **Freeze Cycle – LED 1, 2, and 3 are on.** Comp and PM continue. FM energizes. HGV de-energizes. Appliance is held in freeze by a 5-min. short cycle protection timer. After 5-min. short cycle protection timer terminates and FS opens, freeze cycle terminates. Note: PM power supply continues from CB K1 #4 (DBU) in harvest and in freeze.

Anti-Slush: When anti-slush control is enabled (S5 dip switch 5 “ON”), PM de-energizes when thermistor reaches 50°F (10°C) (3.9kΩ) for 10 sec. then, energizes for 50 sec. repeatedly. When thermistor reaches 34°F (1°C) (5.9kΩ) PM de-energizes for 10 sec., energizes for 50 sec., de-energizes for 10 sec., again, then energizes the remainder of the freeze cycle.

- a) **Freeze Cycle Diagnosis:** Confirm Comp and PM continue. Confirm that FM energizes. Confirm WRV opens (water-cooled models). Next, confirm HGV de-energizes. During the first 5 min. of freeze, confirm evaporator is cooling. If not, confirm WV de-energized (not leaking by), HGV de-energized (not bypassing), FM energizes, TXV operates correctly, WRV opens, Comp is efficient, and refrigerant charge is correct. See "VIII.A. Specification and Performance Data Sheets."
- b) **Comp Diagnosis:** If Comp de-energizes once freeze begins, check that appliance has not shut off on HPS (CB "POWER OK" LED off). If so, check "3)b) HPS Diagnosis" above. If CB "POWER OK" LED is on, check for 115VAC at CB K1 #9 (V) to neutral (W). If 115VAC is not present and LED 1 is on, replace CB. If 115VAC is present, check for 115VAC at CR coil. If 115VAC is present, check CR coil and contact continuity. Replace as needed. If CR is okay, check Comp start relay and start capacitor (if applicable). Next, check Comp motor winding continuity. If Comp is energized but evaporator is not cooling, check for an inefficient Comp. See "VIII.A. Specification and Performance Data Sheets."
- c) **WV and HGV Diagnosis:** If WV is energized, check for 115VAC at CB K1 #6 (O) to neutral (W). If 115VAC is present after PM energizes in harvest cycle, replace CB. If 115VAC is not present, replace WV (bypassing). If HGV did not de-energize at the end of harvest, check for 115VAC at CB K1 #2 (P) to neutral (W). If 115VAC is present and LED 2 is off, replace CB. If 115VAC is not present, replace HGV (bypassing).
- d) **PM Diagnosis:** Confirm water is flowing over evaporator from PM and not WV. If PM de-energizes once freeze begins, check for 115VAC at CB K1 #4 (DBU) to neutral (W). If 115VAC is not present, replace CB. If 115VAC is present and PM is de-energized, check PM capacitor and motor winding continuity.
- e) **FM Diagnosis:** If FM does not energize, check for 115VAC at CB K1 #3 (BK) to neutral (W). If 115VAC is not present and LED 2 is on, check for 115VAC at CB K1 #1 (V). If 115VAC is present at #1 (V) and not at #3 (BK), replace CB. If 115VAC is present and LED 2 is on:
For FM, check capacitor, motor winding, and blade for binding.
Note: LED 2 is on for FM and off for HGV.
- f) **Refrigerant Pressures and TXV Diagnosis:** If evaporator is still not cooling, check refrigerant pressures. See "VIII.A. Specification and Performance Data Sheets." Next, check TXV for proper operation (remove TXV bulb and hold it in your hand, refrigerant low-side pressure should rise. Place TXV bulb in ice water, refrigerant low-side pressure should drop). A 10 to 15 pound pressure swing between warm and cold conditions indicate a good TXV. If a 10 to 15 pound swing is not present, replace TXV.

g) **WRV Diagnosis:** WRV is factory set and generally no adjustment is required. If WRV fails to open in freeze, check for proper refrigerant pressures. See "VIII.A. Specification and Performance Data Sheets." If refrigerant pressures are correct and WRV does not open, adjust or replace as needed. See "IV.C. Water Regulating Valve Adjustment (water-cooled models)."

h) **Freeze Termination Diagnosis:** After 5 min. in freeze, disconnect CB K5 FS connector. 15 sec. later appliance should switch out of the freeze cycle (15 second delay after FS opens before terminating the freeze cycle). If appliance remains in freeze longer than 15 sec. after FS removed, replace CB. If appliance switches with FS removed but would previously not switch out of freeze with FS connected (long freeze - 3 beep alarm), see "II.E.2.a) Float Switch Check."

Note: Normal freeze cycle will last 20 to 40 min. depending on model and conditions. Cycle times and pressures should follow performance data provided in this manual. See "VIII.A. Specification and Performance Data Sheets."

i) **Short Freeze Cycle Diagnosis:** Confirm water tank fills and overflows during 1 min. fill and harvest cycles. If not, check water supply filters, shut-off valve, WV screen. If water tank empties before 5 min. timer terminates and freeze cycle is short, check that DV is not leaking by (water flowing down the drain). If DV is leaking by, remove and clean DV, replace if necessary. If water tank is full, see "II.E.2.a) Float Switch Check." for erratic operating FS.

7) **Pump-Out Cycle – LEDs 1, 3, and 5 are on (10/20 second pump-out).** Timing of the first pump-out is determined by S4 dip switch 5. See the table below.

Control Board Settings		
S4 Dip Switch Setting	Pump-Out Frequency	Control Board
No. 5		
OFF	Every 10 cycles	After 11th freeze cycle
ON	Every cycle	After 2nd freeze cycle

Comp continues, HGV energizes.

Note: If S4 dip switch 3 & 4 are set to 3 off and 4 on, LED 4 turns on and WV energizes.

NOTICE! S5 dip switch 1 must not be adjusted. This is the pump-out circulation selection and allows DV to energize in pump-out.

FM de-energizes. PM stops for 2 sec., then PM and DV energize for 10/20 sec.

depending on pump-out timer (S4 dip switch 3 & 4) setting. When the pump-out timer terminates, pump-out is complete. The pump-out frequency control (S4 dip switch 5) is factory set, and generally no adjustment is required. However, the pump-out frequency control can be set to have a pump-out occur every 10 cycles or every cycle. For details, see "III.C.2.d) Pump-Out Frequency Control (S4 dip switch 5)."

Pump-Out Diagnosis: In the freeze cycle before pump-out (see table above), after 5 min. of freeze, disconnect CB black K5 connector (FS connector). Check that PM stops and re-starts. Next, check that PM and DV energized (water flowing down the drain through DV). If PM does not stop and re-start, check that CB LEDs 1, 3, and 5 are on. If not, replace CB. If LEDs 1, 3, and 5 are on and PM does not energize, check for 115VAC at CB K1 #4 (DBU) to neutral (W). If 115VAC is not present, replace CB. If not, check PM motor windings and impeller for binding. If energized, make sure DV energized. If not, check for 115VAC at CB K1 #5 (GY). If 115VAC is not present and LED 5 is on, replace CB. If 115VAC is present, check DV solenoid continuity. Replace as needed. If DV is energized and open, check that the drain line is not clogged.

Confirm FM de-energizes. If FM is energized with LEDs 1, 3, and 5 on, replace CB.

8) **Normal Harvest Cycle** – Same as the initial harvest cycle. Return to step 5a) above.

Note: Appliance continues to cycle until BC is satisfied or power is switched off.

The appliance always restarts at the 1-min. fill cycle.

b) Shutdown Diagnosis

1) See "II.D.1b. Bin Control Check - H+ Control Board (2B0161-01)."

Legend: **BC**–bin control; **CB**–control board; **Comp**–compressor; **CR**–compressor relay; **CT**–control transformer; **DV**–drain valve; **FM**–fan motor; **FS**–float switch; **HGV**–hot gas valve; **HPS**–high-pressure switch; **LLV**–liquid line valve; **PM**–pump motor; **TXV**–thermostatic expansion valve; **WRV**–water regulating Valve; **WV**–inlet water valve

C. Control Board Check

1. H Control Board (P01771-02)

Before replacing CB that does not show a visible defect and that you suspect is bad, always conduct the following check procedure. This procedure will help you verify your diagnosis.

Alarm Reset: If CB is in alarm (beeping), press the "ALARM RESET" button on CB while CB is beeping. **WARNING! Risk of electric shock. Care should be taken not to touch live terminals.** Once reset, the icemaker starts at the 1-minute fill cycle. For audible alarm information, see "III.B. LED Lights and Audible Alarm Safeties."

- 1) Check the dip switch settings to assure that S1 dip switch 3, 4, 7, 8, 9, 10 and S2 dip switch 1 through 6 are in the factory default position. S1 dip switch 1, 2, 5, 6 are cleaning adjustments and the settings are flexible. For factory default settings, see "III.C.1.a) Default Dip Switch Settings."
- 2) Move the control switch to the "ICE" position. If the red CB "POWER OK" LED is on, control voltage is good, continue to step 3. If CB "POWER OK" LED is off, check CT secondary circuit. CT output is 10.5VAC at 115VAC primary input. If the secondary circuit has proper voltage and the red LED is off, replace CB.

If the secondary circuit does not have proper voltage, check CT primary circuit. Check for 115VAC at CB K3 connector pin #1 (P) to neutral (W) for 115VAC. Always choose a white (W) neutral wire to establish a good neutral connection when checking voltages. For additional checks, see "II.H.1. No Ice Production."

- 3) The "OUTPUT TEST" button provides a relay sequence test. Make sure the control switch is in the "ICE" position, then press the "OUTPUT TEST" button. For the correct lighting sequence, see the table below. Note that the order of the LEDs from the outer edge of the control board is 5, 6, 8, 9, 4 and 7. Components (e.g., compressor) cycle during the test.

Following the test, the icemaker begins operation at the 1-minute fill cycle. If the LEDs do not light as described above, replace CB.

- 4) With the icemaker in the cycle to be tested, check output voltage from the corresponding pin on CB connectors to a neutral (W) wire. If output voltage is not found and the appropriate LED is on, replace CB.

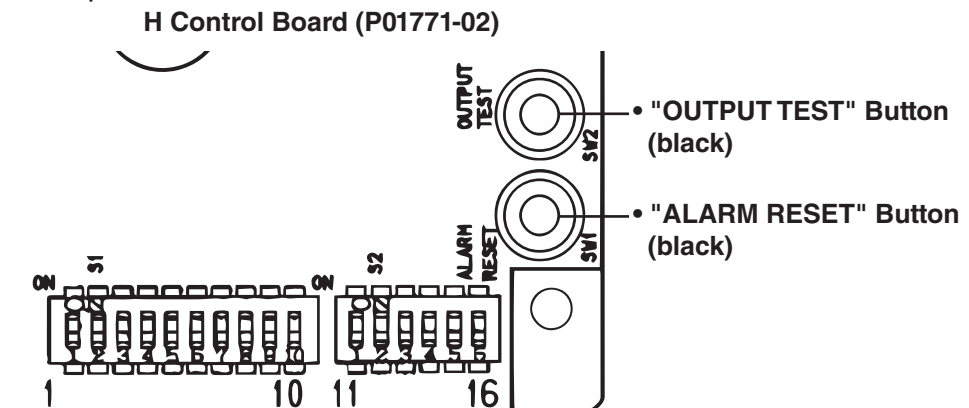

Fig. 1

2. H+ Control Board (2B0161-01)

Before replacing CB that does not show a visible defect and that you suspect is bad, always conduct the following check procedure. This procedure will help you verify your diagnosis.

Alarm Reset: If CB is in alarm (beeping), press the "ALARM RESET" button on CB while CB is beeping. **WARNING! Risk of electric shock. Care should be taken not to touch live terminals.** Once reset, the icemaker starts at the 1-minute fill cycle. For audible alarm information, see "III.B. LED Lights and Audible Alarm Safeties."

- 1) Check the dip switch settings to assure that S4 dip switch 3, 4, 7, 8, 9, 10 and S5 dip switch 1 through 5 are in the factory default position. S4 dip switch 1, 2, 5, 6 are cleaning adjustments and the settings are flexible. For factory default settings, see "III.C.2.a) Default Dip Switch Settings."
- 2) Move the control switch to the "ICE" position. If the red CB "POWER OK" LED is on, control voltage is good, continue to step 3. If CB "POWER OK" LED is off, check CT secondary circuit. CT output is 10.5VAC at 115VAC primary input. If the secondary circuit has proper voltage and the red LED is off, replace CB.

If the secondary circuit does not have proper voltage, check CT primary circuit. Check for 115VAC at CB K3 connector pin #1 (P) to neutral (W) for 115VAC. Always choose a white (W) neutral wire to establish a good neutral connection when checking voltages. For additional checks, see "II.H.1. No Ice Production."

- 3) The "OUTPUT TEST" button provides a relay sequence test. Make sure the control switch is in the "ICE" position, then press the "OUTPUT TEST" button. For the correct lighting sequence, see the table below. Note that the order of the LEDs from the outer edge of the control board is 1, 4, 5, 3, 2. Components (e.g., compressor) cycle during the test.

Following the test, the icemaker begins operation at the 1-minute fill cycle. If the LEDs do not light as described above, replace CB.

- 4) With the icemaker in the cycle to be tested, check output voltage from the corresponding pin on CB connectors to a neutral (W) wire. If output voltage is not found and the appropriate LED is on, replace CB.

Legend: **CB**—control board; **CT**—control transformer

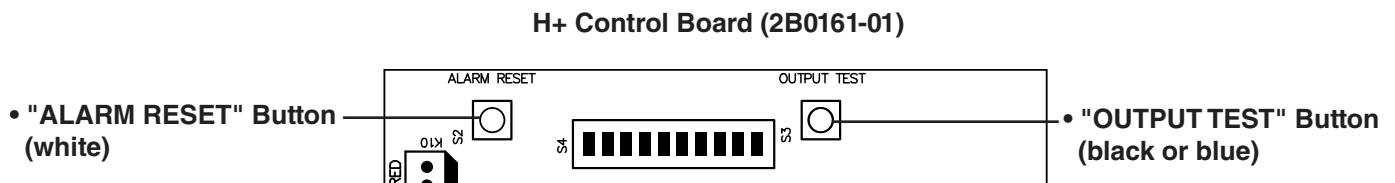

Fig. 2

D. Bin Control Check

1a. Bin Control Check - H Control Board (P01771-02)

This appliance uses a mechanical bin control to control the ice level in the storage bin. No adjustment is required.

To check BC, follow the steps below.

- 1) Remove the louver, move the control switch to the "OFF" position, then unplug the icemaker from the electrical outlet.
- 2) Clear any ice away from BC.
- 3) Remove the control box, then disconnect CB K1 connector from CB.
- 4) Check for continuity across BC leads. When the actuator paddle is not engaged, BC switch is closed. If open, check that the actuator paddle is not sticking. Clean if necessary. See "II.D.2. Bin Control Cleaning." If BC switch still reads open, replace BC.
- 5) Press and hold the actuator paddle; check for continuity across the wires of the BC connector. When the actuator paddle is engaged, BC switch is open. If closed, check that the actuator paddle is not restricted. Clean if necessary. See "II.D.2. Bin Control Cleaning." If BC switch still reads closed, replace BC.
- 6) Reconnect CB K1 connector to CB. Next, move the control switch to the "ICE" position.
- 7) Plug the icemaker into the electrical outlet.
- 8) Allow the icemaker to cycle into the freeze cycle. Once in the freeze cycle, press and hold the actuator. CB "POWER OK" LED starts flashing and the icemaker shutdown sequence begins. See "II.A.2. Shutdown Flow Chart". Once components de-energize, there is a 2 sec. delay, then the DV and PM energize for a max of 5 min. or until FS opens. See "III.C.1.a) Default Dip Switch Settings". If icemaker shutdown sequence does not begin, check that the BC/CB connector is securely connected and CB "POWER OK" LED is flashing. If so, and shutdown does not start, replace CB.
- 9) Replace the control box and louver in their correct position.

Legend: **BC**—bin control; **CB**—control board; **DV**—drain valve

1b. Bin Control Check - H+ Control Board (2B0161-01)

This appliance uses a mechanical bin control to control the ice level in the storage bin. No adjustment is required.

To check BC, follow the steps below.

- 1) Remove the louver, move the control switch to the "OFF" position, then unplug the icemaker from the electrical outlet.
- 2) Clear any ice away from BC.
- 3) Remove the control box, then disconnect CB K4 connector from CB.
- 4) Check for continuity across BC leads. When the actuator paddle is not engaged, BC switch is closed. If open, check that the actuator paddle is not sticking. Clean if necessary. See "II.D.2. Bin Control Cleaning." If BC switch still reads open, replace BC.
- 5) Reach under the evaporator and water tank and press and hold the actuator paddle; check for continuity across the wires of the BC connector. When the actuator paddle is engaged, BC switch is open. If closed, check that the actuator paddle is not restricted. Clean if necessary. See "II.D.2. Bin Control Cleaning." If BC switch still reads closed, replace BC.
- 6) Reconnect CB K4 connector to CB. Next, move the control switch to the "ICE" position.
- 7) Plug the icemaker into the electrical outlet.
- 8) Allow the icemaker to cycle into the freeze cycle. Once in the freeze cycle, press and hold the actuator. CB "BC OPEN/CLOSED" LED turns on and the icemaker shutdown sequence begins. See "II.A.2. Shutdown Flow Chart". Once components de-energize, there is a 2 sec. delay, then the DV and PM energize until FS opens. See "III.C.2.a) Default Dip Switch Settings". If icemaker shutdown sequence does not begin, check that the BC/CB connector is securely connected and CB "BC OPEN/CLOSED" LED is on. If so, and shutdown does not start, replace CB.
- 9) Replace the control box and louver in their correct position.

Note: **H+ CB** does not have a 5 min. max timer once DV and PM energize.

Legend: **BC**—bin control; **CB**—control board; **DV**—drain valve

2. Bin Control Cleaning

Scale may build up on BC. Scale can cause the actuator paddle and magnet to stick. In this case, BC should be cleaned.

WARNING

CHOKING HAZARD: Ensure all components, fasteners, and thumbscrews are securely in place after the icemaker is serviced. Make sure that none have fallen into the dispense unit/ice storage bin.

- 1) Remove the louver, then move the control switch to the “OFF” position. Move the service switch to the “DRAIN” position, then move the control switch to the “SERVICE” position. Allow the water tank to drain completely.
- 2) After all of the water has drained, move the control switch to the “OFF” position, then unplug the icemaker from the electrical outlet.
- 3) Clear any ice away from BC.
- 4) Disconnect the overflow pipe, then remove the 2 water tank thumbscrews. Remove the water tank. See Fig. 3.

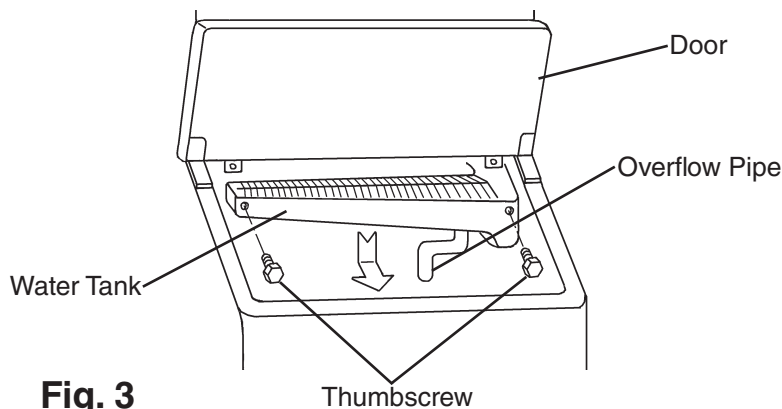

Fig. 3

- 5) Remove one of the bin control thumbscrews, then loosen the other bin control thumbscrew and then slide the bin control assembly over. Next, rotate the bin control assembly to the front to view the proximity switch. See Fig. 4.
- 6) Remove the proximity switch from the bin control assembly, then remove the bin control assembly.

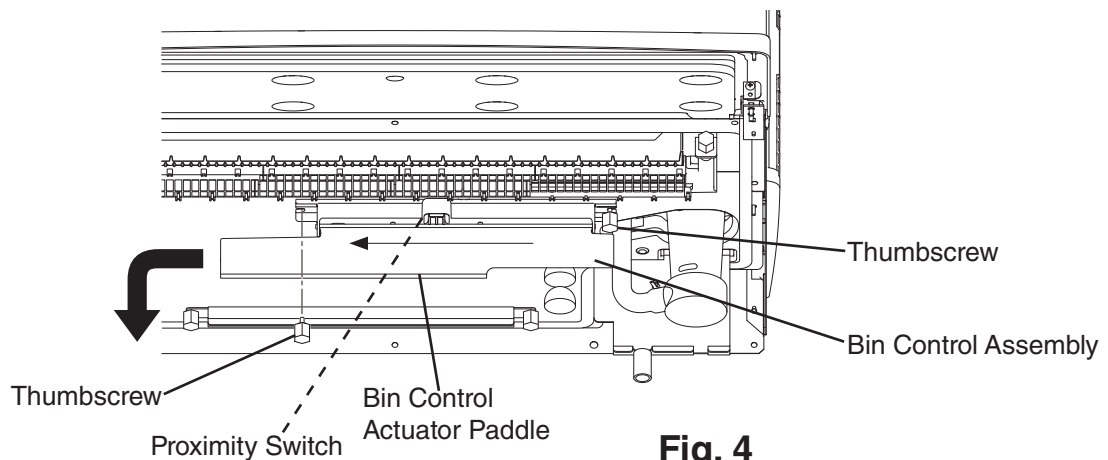

Fig. 4

- 7) Remove the actuator paddle from the switch mount.
- 8) Wipe down the switch mount and actuator paddle with 1 part of Hoshizaki "Scale Away" and 25 Parts warm water. Rinse the switch mount and actuator paddle thoroughly with clean water.
- 9) Replace the actuator paddle back on the switch mount. Replace the proximity switch.
- 10) Replace and secure the bin control assembly back in its correct position.
- 11) Replace and secure the water tank back in its correct position.
- 12) Move the control switch to the "ICE" position.
- 13) Plug the icemaker back into the electrical outlet to start the automatic icemaking process.
- 14) Replace the louver back in its correct position.

Legend: **BC**–bin control; **CB**–control board

E. Float Switch Check and Cleaning

FS is used to determine that there is sufficient water in the water tank after the 1-min. fill cycle and after each harvest cycle. FS is also used to determine that the appropriate volume of water has been converted into ice before switching out of the freeze cycle. No adjustment is required.

1. H Control Board (P01771-02)

a) Float Switch Check

To check FS, follow the steps below.

- 1) Remove the louver, then move the control switch to the “OFF” position. Move the service switch to the “DRAIN” position, then move the control switch to the “SERVICE” position. Allow the water tank to drain completely.
- 2) After all of the water has drained, move the control switch to the “OFF” position, then unplug the icemaker from the electrical outlet.
- 3) Remove the control box mounting screws and lower the control box access CB.
- 4) Disconnect CB K1 connector from CB.
- 5) Check for continuity across FS leads. With the water tank empty, FS should be open. If open, continue to step 6. If closed, follow the steps in “II.E. 1.b) Float Switch Cleaning.” After cleaning FS, check it again. Replace if necessary.
- 6) Reconnect CB K1 connector to CB, then replace the control box in its correct position.
- 7) Plug the icemaker back into the electrical outlet, then move the control switch to the “ICE” position. After 1 min., the 1-min. fill cycle should end and the initial harvest cycle should begin. If the initial harvest cycle begins, FS is good and the check is complete. If the initial harvest cycle does not begin, continue to step 8.
- 8) Move the control switch to the “OFF” position, then unplug the icemaker from the electrical outlet
- 9) Remove the control box mounting screws and lower the control box access CB.
- 10) Disconnect CB K1connector CB.
- 11) Check for continuity across FS leads (2 black (BK) wires). With the water tank full, FS should be closed. If FS is closed and the icemaker will not switch from the 1-min. fill cycle to the initial harvest cycle, replace CB. If FS is open, confirm that the water tank is full. If the water tank is not full, check the water supply, water filters, and inlet water valve. If the water tank is full, follow the steps in “II.E. 1.b) Float Switch Cleaning.” After cleaning FS, check it again. Replace if necessary.

Legend: **CB**—control board; **FS**—float switch

b) Float Switch Cleaning

Depending on local water conditions, scale may build up on FS. Scale on the switch can cause the float to stick. In this case, FS should be cleaned.

- 1) Remove the louver, then move the control switch to the “OFF” position. Move the service switch to the “DRAIN” position, then move the control switch to the “SERVICE” position. Allow the water tank to drain completely.
- 2) After all of the water has drained, move the control switch to the “OFF” position, then unplug the icemaker from the electrical outlet.
- 3) Remove the top and upper rear panels.
- 4) Locate FS on the compressor base. See Fig. 5. Remove the screw securing FS to the compressor base and lift FS from the icemaker.

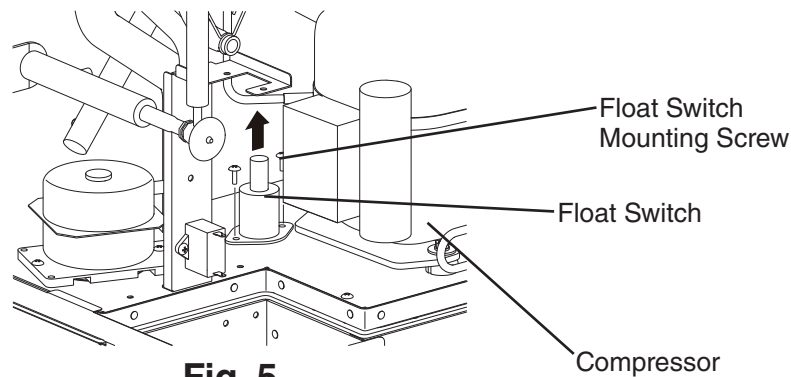

Fig. 5

- 5) Remove the retainer clip from FS shaft, then remove the float. Be careful not to damage or lose the retaining clip when removing it. See Fig. 6.
- 6) Wipe down FS housing, shaft, float, and retainer clip with a mixture of 1 part Hoshizaki “Scale Away” and 25 parts warm water. Rinse the parts thoroughly with clean water.
- 7) Reassemble FS assembly and replace and secure it in its correct position.
- 8) Replace the upper rear and top panels.
- 9) Plug the icemaker into the electrical outlet.
- 10) Move the control switch to the “ICE” position to start the automatic icemaking process.
- 11) Replace the louver in its correct position.

Legend: **CB**—control board; **FS**—float switch

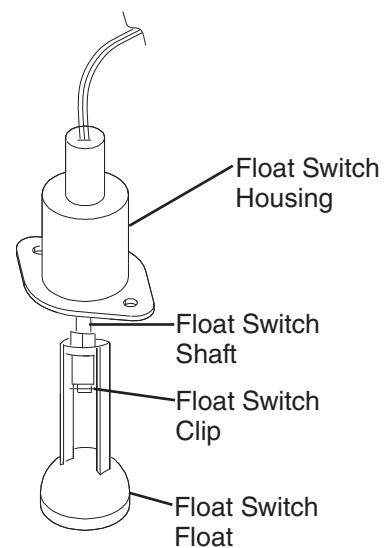

Fig. 6

2. H+ Control Board (2B0161-01)

a) Float Switch Check

To check FS, follow the steps below.

- 1) Remove the louver, then move the control switch to the “OFF” position. Move the service switch to the “DRAIN” position, then move the control switch to the “SERVICE” position. Allow the water tank to drain completely.
- 2) After all of the water has drained, move the control switch to the “OFF” position, then unplug the icemaker from the electrical outlet.
- 3) Remove the control box mounting screws and lower the control box access CB.
- 4) Disconnect CB K5 connector from CB.
- 5) Check for continuity across FS leads. With the water tank empty, FS should be open. If open, continue to step 6. If closed, follow the steps in “II.E.2.b) Float Switch Cleaning.” After cleaning FS, check it again. Replace if necessary.
- 6) Reconnect CB K5 connector to CB, then replace the control box in its correct position.
- 7) Plug the icemaker back into the electrical outlet, then move the control switch to the “ICE” position. After 1 min., the 1-min. fill cycle should end and the initial harvest cycle should begin. If the initial harvest cycle begins, FS is good and the check is complete. If the initial harvest cycle does not begin, continue to step 8.
- 8) Move the control switch to the “OFF” position, then unplug the icemaker from the electrical outlet
- 9) Remove the control box mounting screws and lower the control box access CB.
- 10) Disconnect CB K5 connector CB.
- 11) Check for continuity across FS leads (2 black (BK) wires). With the water tank full, FS should be closed. If FS is closed and the icemaker will not switch from the 1-min. fill cycle to the initial harvest cycle, replace CB. If FS is open, confirm that the water tank is full. If the water tank is not full, check the water supply, water filters, and inlet water valve. If the water tank is full, follow the steps in “II.E.2.b) Float Switch Cleaning.” After cleaning FS, check it again. Replace if necessary.

Legend: **CB**–control board; **FS**–float switch

b) Float Switch Cleaning

Depending on local water conditions, scale may build up on FS. Scale on the switch can cause the float to stick. In this case, FS should be cleaned.

- 1) Remove the louver, then move the control switch to the “OFF” position. Move the service switch to the “DRAIN” position, then move the control switch to the “SERVICE” position. Allow the water tank to drain completely.
- 2) After all of the water has drained, move the control switch to the “OFF” position, then unplug the icemaker from the electrical outlet.
- 3) Remove the top and upper rear panels.
- 4) Locate FS on the compressor base. See Fig. 7. Remove the screw securing FS to the compressor base and lift FS from the icemaker.

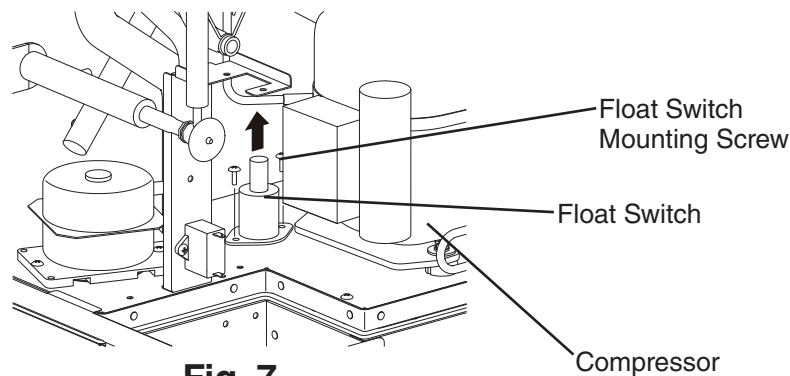

Fig. 7

- 5) Remove the retainer clip from FS shaft, then remove the float. Be careful not to damage or lose the retaining clip when removing it. See Fig. 8.
- 6) Wipe down FS housing, shaft, float, and retainer clip with a mixture of 1 part Hoshizaki “Scale Away” and 25 parts warm water. Rinse the parts thoroughly with clean water.
- 7) Reassemble FS assembly and replace and secure it in its correct position.
- 8) Replace the upper rear and top panels.
- 9) Plug the icemaker into the electrical outlet.
- 10) Move the control switch to the “ICE” position to start the automatic icemaking process.
- 11) Replace the louver in its correct position.

Legend: **CB**—control board; **FS**—float switch

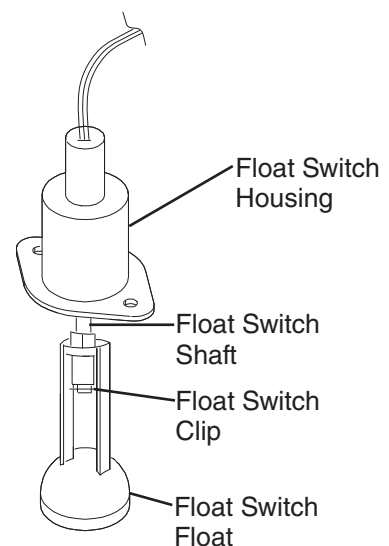

Fig. 8

F. Thermistor Check

To check thermistor resistance, follow the steps below.

- 1) Unplug the icemaker from the electrical outlet.
- 2) Remove the louver, then move the control switch to the “OFF” position.
- 3) Remove the top panel.
- 4) Remove the thermistor from the refrigerant tubing.
- 5) Immerse the thermistor sensor portion in a glass containing ice and water for 2 or 3 min.
- 6) From the compressor area, locate the thermistor/CB connector protective plastic bundle. Open the protective plastic bundle and remove the thermistor/CB connector from the protective plastic bundle.
- 7) Disconnect the thermistor connector from CB connector and check the resistance between thermistor leads. Normal range is 4.7 to 6.2 k Ω . If outside the normal range, replace the thermistor. See “IV.B. Component Service Information.” If within the normal range, continue to the next step.
- 8) Replace the thermistor in its correct position. See “IV.B. Component Service Information.”
- 9) Reconnect the thermistor connector to CB connector and re-secure in the protective plastic cover.
- 10) Replace the top panel in its correct position.
- 11) Plug the icemaker into the electrical outlet, then move the control switch to the “ICE” position to start the automatic icemaking process.
- 12) Replace the louver in its correct position.
- 13) Once the harvest cycle starts (Comp energizes), begin timing the harvest cycle.
- 14) The harvest timer and harvest cycle should terminate within 2 to 5 min. If the harvest cycle does not terminate within 2 to 5 min., replace CB.

Legend: **CB**—control board; **Comp**—compressor

G. Switches

Two control switches are used to control operation. These switches are referred to as the “control switch” and the “service switch” and are located on the control box.

1. Control Switch

The control switch has three positions: “OFF” for power off, “ICE” for icemaking, and “SERVICE” to activate the service switch.

2. Service Switch

When the control switch is in the “SERVICE” position, the control switch supplies power to the service switch and the machine is in service mode. The service switch has three positions: “DRAIN,” “CIRCULATE,” and “WASH.” See the information below for details of each function.

Note: 1. When the service switch is activated, power is supplied to the water pump in all three positions.

2. When the control switch is in the “OFF” position or in the “ICE” position, the service switch has no power and can be left in any position.

a) DRAIN

This model utilizes a pump-out drain system. When the service switch is active and placed in the “DRAIN” position, power is supplied to the pump, service relay, and drain valve.

b) CIRCULATE

When the service switch is active and placed in the “CIRCULATE” position, power is supplied to the pump only. This operation can be used to circulate cleaner for extended periods of time over the outside surface of the evaporator.

c) WASH

This model utilizes a solenoid operated wash (bypass) valve. When the service switch is active and placed in the “WASH” position, power is supplied to the pump and the wash valve. This operation is used to circulate cleaner and sanitizer over both the inside and outside of the evaporator.

H. Diagnostic Tables

1. No Ice Production

No Ice Production - Possible Cause	
1. Power Supply	a) Off, blown fuse, or tripped breaker.
	b) Unplugged or loose connection
	c) Not within specifications.
2. Fuse (Control Box)	a) Blown.
3. Control Switch	a) In "OFF" or "SERVICE" position.
	b) Bad contacts.
4. High-Pressure Switch	a) Dirty condenser.
	b) Fan motor not operating.
	c) Refrigerant overcharged.
	d) Bad contacts.
	e) Refrigerant lines or components plugged.
	f) HGV defective.
5. Control Transformer (115VAC/10.5VAC)	a) Coil winding open or shorted.
6. Control Board See "II.C. Control Board Check"	a) In alarm.
	b) CB "POWER OK" LED flashing (bin full).
	c) Defective.
7. Bin Control See "II.D. Bin Control Check"	a) Tripped with bin filled with ice.
	b) Actuator does not move freely.
	c) Defective.
8. Water Supply	a) Water supply off or improper water pressure.
	b) External water filters clogged.
9. Inlet Water Valve	a) Screen or orifice clogged.
	b) Coil winding open.
	c) Water valve open in freeze cycle.
10. Float Switch See "II.E. Float Switch Check and Cleaning"	a) Float does not move freely.
	b) Defective.
11. Compressor	a) Compressor relay contacts bad or coil winding open.
	b) Start capacitor defective.
	c) External protector open.
	d) Start relay contacts bad or coil winding open.
	e) Compressor defective.
12. Hot Gas Valve	a) Closed in harvest cycle.
	b) Open in freeze cycle.
13. Thermistor See "II.F. Thermistor Check"	a) Loose, disconnected, or defective.
14. Pump Motor	a) Motor winding open.
	b) Bearing worn out or locked rotor.
	c) Defective capacitor.
	d) Mechanical seal worn out.

No Ice Production - Possible Cause	
15. Thermostatic Expansion Valve	a) Bulb loose.
	b) Operating erratically.
16. Fan Motor	a) Motor winding open.
	b) Bearing worn out or locked rotor.
	c) Defective capacitor.
17. Water System	a) Water leaks causing short freeze time.

2. Freeze-Up

Defrost and clean the icemaker prior to diagnosing freeze-up. Fill out a freeze-up checklist. See “II.I. Freeze Up Check List,” the Hoshizaki America Technician’s Pocket Guide, or contact your local distributor for a copy of the freeze-up checklist.

Freeze-Up - Possible Cause	
Harvest Cycle	
1. Evaporator	a) Scaled up.
	b) Damaged.
2. Cube Guides	a) Out of position.
	b) Damaged.
3. Spray Tubes and/or Spray Guides	a) Dirty.
	b) Out of position.
4. Water Supply	a) Low water pressure.
	b) External water filters clogged.
	c) Insufficient water line size. Minimum 1/4" Nominal ID (6 mm Nominal OD in the EU) copper water tubing or equivalent.
5. Inlet Water Valve	a) Screen or orifice clogged.
	b) Defective.
6. Float Switch See “II.E. Float Switch Check and Cleaning”	a) Dirty, sticking.
	b) Defective.
7. Refrigerant Charge	a) Low.
8. Control Board See “III.C. Settings and Adjustments” and “II.C. Control Board Check”	a) Harvest timer (S1 dip switch 1 & 2) set too short.
	b) Harvest pump timer (S1 dip switch 7) not in factory default position.
	c) Defective.
9. Bin Control See “II.D. Bin Control Check”	a) Actuator does not move freely.
10. Thermistor See “II.F. Thermistor Check”	a) Loose, disconnected, or defective.
11. Thermostatic Expansion Valve	a) Defective.
12. Hot Gas Valve	a) Closed or restricted.

Freeze-Up - Possible Cause	
Freeze Cycle	
1. Evaporator	a) Scaled up. b) Damaged.
2. Spray Tubes and/or Spray Guides	a) Dirty. b) Out of position.
3. Refrigerant Charge	a) Low.
4. Control Board See "II.C. Control Board Check"	a) Freeze timer (S1 dip switch 9 & 10) set incorrectly. b) Defective.
5. Inlet Water Valve	a) Leaking by.
6. Float Switch See "II.E. Float Switch Check and Cleaning"	a) Float does not move freely. b) Defective.
7. Pump Motor	a) RPM too slow. b) Impeller damaged.
8. Thermostatic Expansion Valve	a) Bulb loose or defective.

3. Low Ice Production

Low Ice Production - Possible Cause	
Long Harvest Cycle	
1. Evaporator	a) Scaled up.
2. Spray Tubes and/or Spray Guides	a) Dirty. b) Out of position.
3. Refrigerant Charge	a) Low.
4. Water Supply	a) Low water pressure. b) External water filters clogged. c) Insufficient water line size. Minimum 1/4" Nominal ID (6 mm Nominal OD in the EU) water tubing or equivalent. d) Too cold.
5. Control Board See "II.C. Control Board Check"	a) Thermistor connection loose (K3). b) Defective.
6. Thermistor See "II.F. Thermistor Check"	a) Loose, disconnected, or defective.
7. Hot Gas Valve	a) Erratic or closed.
8. Inlet Water Valve	a) Screen or orifice clogged.
9. Compressor	a) Inefficient or off.
10. Thermostatic Expansion Valve	a) Defective.

Low Ice Production - Possible Cause	
Long Freeze Cycle	
1. Evaporator	a) Scaled up, dirty.
2. Float Switch See "II.E. Float Switch Check and Cleaning"	a) Scaled up, dirty.
	b) Float sticking.
	c) Defective switch.
3. Inlet Water Valve	a) Leaking by.
4. Hot Gas Valve	a) Erratic or open.
5. Condenser	a) Clogged.
6. Control Board See "II.C. Control Board Check"	a) Float switch connection loose (K5).
	b) Defective.
7. Refrigerant Charge	a) Low.
8. Thermostatic Expansion Valve	a) Bulb loose.
	b) Defective.
9. Compressor	a) Inefficient or off.
10. Pump Motor	a) RPM too slow.

I. Freeze-Up Check List

Freeze-Up Check List
Please Complete When Diagnosing a Freeze-Up, Refrigerant Leak, or Low Charge
 Technical Support Fax #: 770-487-3360
 Make Copies And Use As Needed

Model # _____ **Serial #** _____ **Install Date** _____ **Fail Date** _____

List model and manufacture of bin or dispenser _____.

Date appliance was last cleaned: _____.

Freeze-Up Defrost

YES NO

- 1) After defrosting, was the appliance leak checked?
- 2) Were any leaks found?
If so where? _____.
- 3) Was any refrigerant added to the unit?
If so, how much? _____.

Set Up

- 4) Is the appliance stand alone?
- 5) Is water line independent?
- 6) Is water line correct size? If not _____,"
3/8" Nominal ID Copper Water Tubing or Equivalent.
- 7) What is water pressure? _____.
Water Temperature _____.
- 8) Does appliance have any water filtration?
If yes please list the following:
Filter brand _____.
Model _____.
Filter pressure gauge reading during the fill cycle _____.
Date filter was last replaced? _____.
GPM or LPM flow rate of filter system? _____.
- 9) Ambient temperature at appliance? _____.
At remote condenser (if applicable)? _____.

Appliance Status

- 10) Is the appliance and/or float switch dirty?
- 11) List the S1 (1-10) and S2 (1-5) DIP switch settings.
S1: 1 ___ 2 ___ 3 ___ 4 ___ 5 ___ 6 ___ 7 ___ 8 ___ 9 ___ 10 ___
S2: 1 ___ 2 ___ 3 ___ 4 ___ 5 ___ 6 ___
- 12) Is DIP switch number 7 ON (harvest pump time (harvest assist) all models and freeze-time correction models with control board P01771-02)?
- 13) Is the cube guide positioned correctly?
- 14) Are the evaporator separators positioned properly?
- 15) Is the thermistor properly mounted, tight, and insulated?
- 16) Is the TXV bulb properly mounted, tight, and insulated?

Appliance Operation

YES NO

- 17) Are the splash guards in place?
- 18) Does the water tank fill and overflow?
60-90 sec. Note: Larger models may take up to 120 seconds to overflow when empty.
- 19) If NO in step 17, is water flow 5GPM for larger?

Fill

Harvest

- 20) Is the hot gas valve opening?
- 21) Is harvest pump time (harvest assist) utilized (S1 dip switch 7)?
- 22) Is hot gas valve opening in harvest?
- 23) Does water valve close completely when deenergized?
- 24) What was length of harvest? _____.

Freeze

- 25) Is pump motor energized in freeze cycle except during 10-sec. anti-slush. If activated (S2 dip switch 5 on)?
- 26) Water-cooled condenser outlet temperature 5-min. into freeze? _____°F.
- 27) What was length of freeze? _____.
- 28) Is the cube size consistent from inlet to outlet of evaporator?
- 29) Is ice still dropping when next freeze cycle starts?
- 30) What is the ice drop weight? _____.
- 31) What is head pressure?
Freeze _____ Harvest _____.
(Freeze pressure should be taken 5 minutes into the cycle).
- 32) What is suction pressure?
Freeze _____ Harvest _____.
(Freeze pressure should be taken 5 minutes into the cycle).
- 33) When activating bin control, did appliance shutdown within 15 seconds in the first 5 minutes of freeze cycle?

Note: Make copies of this form and use it when diagnosing a freeze up condition. Submit a completed copy of the checklist along with the freeze-up labor claim form.

III. Controls and Adjustments

- A Hoshizaki exclusive control board is employed in KM series appliances.
- All models are pretested and factory adjusted.
- For a control board check procedure, see “I.I.C. Control Board Check.”

<i>NOTICE</i>
<ul style="list-style-type: none">• Fragile, handle very carefully.• The control board contains integrated circuits, which are susceptible to failure due to static discharge. It is especially important to touch the metal part of the icemaker when handling or replacing the control board.• Do not touch the electronic devices on the control board or the back of the control board.• Do not short out power supply to test for voltage.• Always replace the whole control board assembly if it goes bad.

A. Control Board Layout

1. H Control Board - (P01771-02)

H Control Board

- **Relay LEDs (6)**

(indicate which relays are energized as listed below)

- **LED 5 (X1 Relay)**

Compressor (Comp)
Fan Motor-Remote (FMR)

- **LED 6 (X2 Relay)**

Hot Gas Valve (HGV)
Fan Motor (FM)
(FM off when LED on)

- **LED 8 (X4 Relay)**

Inlet Water Valve (WV)
(WV1) on units with 2 inlet water valves

- **LED 9 (X5 Relay)**

Inlet Water Valve 2 (WV2) on units with 2 inlet water valves

- **LED 4 (X6 Relay)**

Drain Valve (DV)

- **LED 7 (X3 Relay)**

Pump Motor (PM)

- **K6 Connector**

Open

- **K1 Connector**

Pins
#1, 3 Float Switch
#2 Open
#4, 5 Bin Control
#6, 7 Thermistor
#8, 9 Open

- **K7 Connector**
Transformer

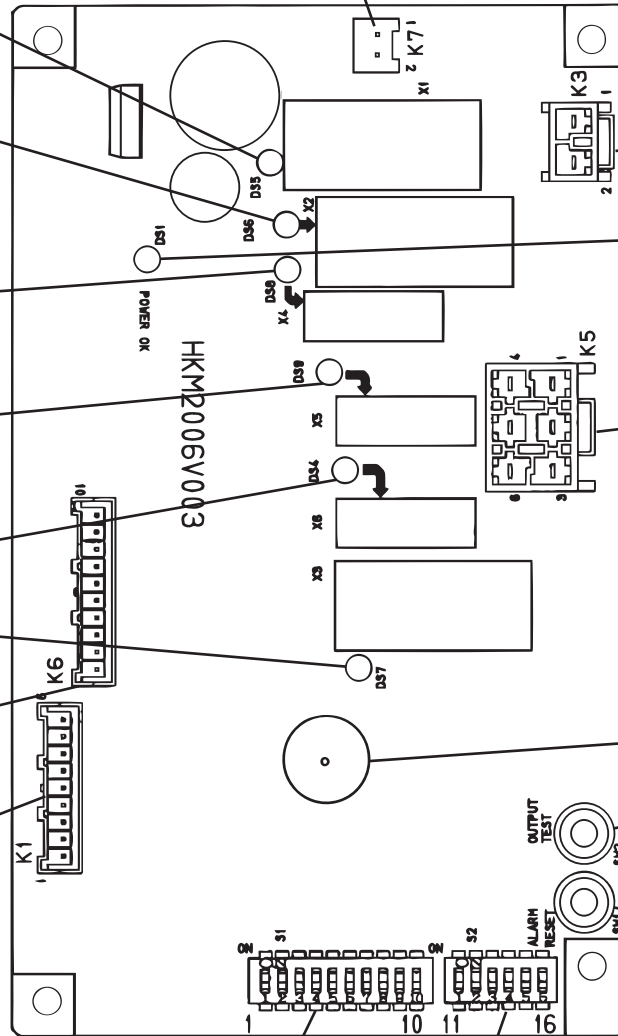

- **K3 Connector**
Power Relay

- **"POWER OK" LED**
(Lights when power is supplied to the board. Flashes when bin control is activated.)

- **K5 Connector**
Pins
#1 Fan Motor (FM)
#2 Hot Gas Valve
#3 Pump Motor
#4 Inlet Water Valve
#5 Open
#6 Drain Valve

- **Alarm Buzzer**

- **"OUTPUT TEST" Button**
(used to test relays on control board)

- **"ALARM RESET" Button**

• S1 Dip Switch • S2 Dip Switch

Control Board	
Part Number	P01771-02

2. H+ Control Board - (2B0161-01)

H+ Control Board

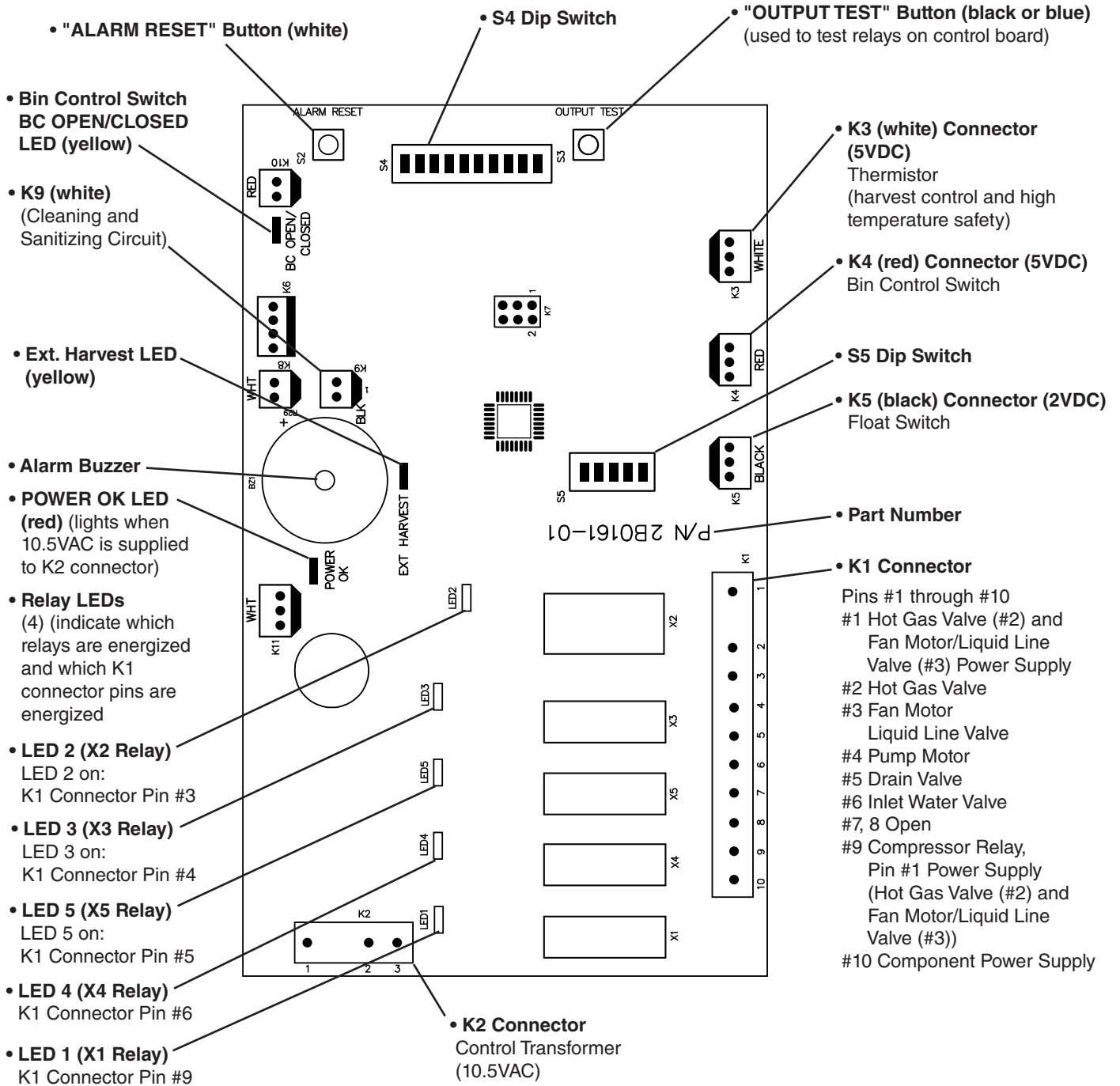

Control Board	
Part Number	2B0161-01

B. LED Lights and Audible Alarm Safeties

1. H Control Board (P01771-02)

Beep occurs and red CB "POWER OK" LED turns on when control switch is moved to "ICE" position.

Sequence

Green LEDs 4 through 8 turn on and sequence from initial startup as listed in the table below. Order of green LEDs from the outer edge of control board is 5, 6, 8, 9, 4, 7.

Sequence Step	LED	Energized Components	Time LEDs are On	
			Min.	Max.
1-Minute Fill Cycle	8	WV		
Harvest Cycle	5, 6, 8	Comp, FM, HGV, WV	2 minutes	20 minutes
Last 0, 10, 30, or 50 seconds (adjustable by dip switch) of harvest, WV de-energizes and PM energizes (LEDs 5, 6, and 7 are on)				
Freeze Cycle	5, 7	Comp, FM, PM	5 minutes	freeze timer setting
Pump-Out Cycle	5, 6, 4,7	Comp, HGV, PM, DV	10 seconds	20 seconds

Alarms

Type	Alarm	Notes
1 Beep	High Evaporator Temp. (temperature > 127°F) (53°C)	Check for harvest problem (stuck HGV or relay), hot water entering unit, or shorted thermistor.
2 Beep	Harvest Backup Timer (harvest > 20 min. for two cycles in a row)	Check thermistor (open), HGV not opening, TXV leaking by, low charge, inefficient Comp, or WRV leaking by.
3 Beep	Freeze Timer (freeze > freeze timer setting for two cycles in a row)	Check FS stuck closed (up), WV leaking by, HGV leaking by, PM not pumping, TXV defective, low charge, or inefficient Comp.
To reset above safeties, press "ALARM RESET" button with power supply on.		
6	Low Voltage (92Vac±5% or less)	Red LED turns off if voltage protection operates. Control voltage safeties automatically reset when voltage is corrected.
7	High Voltage (147Vac±5% or more)	

Legend: **Comp**—compressor; **DV**—drain valve, **FM**—fan motor; **FS**—float switch; **HGV**—hot gas valve; **PM**—pump motor; **TXV**—thermostatic expansion valve; **WRV**—water regulating valve; **WV**—inlet water valve

2. H+ Control Board (2B0161-01)

Beep occurs and red CB "POWER OK" LED turns on when control switch is moved to "ICE" position.

Sequence

Green LEDs 1 through 5 turn on and sequence from initial startup as listed in the table below. Order of green LEDs from the outer edge of control board is 1, 4, 5, 3, 2.

Sequence Step	LED	Energized Components	Time LEDs are On	
			Min.	Max.
1-Minute Fill Cycle	4	WV		
Harvest Cycle	1, 4	Comp, FMR, HGV, WV	1 minute	20 minutes
Harvest Pump Time (harvest assist)	1, 3	Comp, FMR, HGV, PM	0 seconds	50 seconds
Freeze Cycle	1, 2, 3	Comp, FM/FMR, PM, LLV	5 minutes	freeze timer setting
Anti-Slush Control	1, 2	Comp, FM/FMR, LLV	PM off 10 sec. when thermistor at 36°F (2°C)	
Pump-Out Cycle	1, 4, 5, 3	Comp, FMR, HGV, PM, WV*, DV	10 seconds	20 seconds
*pump-out timer setting				

Alarms

Type	Alarm	Notes
1 Beep	High Evaporator Temp. (temperature > 127°F) (53°C)	Check for harvest problem (stuck HGV or relay), hot water entering unit, stuck HM, or shorted thermistor.
2 Beep	Harvest Backup Timer (harvest > 20 min. for two cycles in a row)	Check thermistor (open), HGV not opening, TXV or LLV leaking by, low charge, inefficient Comp, or WRV leaking by.
3 Beep	Freeze Timer (freeze > freeze timer setting for two cycles in a row)	Check FS stuck closed (up), WV leaking by, HGV leaking by, PM not pumping, TXV defective, LLV not opening, low charge, HM not bypassing, or inefficient Comp.
To reset above safeties, press "ALARM RESET" button with power supply on.		
6	Low Voltage (92Vac±5% or less)	Red LED turns off if voltage protection operates. Control voltage safeties automatically reset when voltage is corrected.
7	High Voltage (147Vac±5% or more)	

Legend: **Comp**—compressor; **DV**—drain valve; **FM**—fan motor; **FMR**—fan motor remote; **FS**—float switch; **HGV**—hot gas valve; **HM**—headmaster (C.P.R.); **LLV**—liquid line valve; **PM**—pump motor; **TXV**—thermostatic expansion valve; **WRV**—water regulating valve; **WV**—inlet water valve

C. Settings and Adjustments

NOTICE

Dip switches are factory set. Failure to maintain factory settings may adversely affect performance and warranty coverage. For more information, contact your Hoshizaki Service Center.

1. H Control Board (P01771-02)

a) Default Dip Switch Settings

The dip switches are factory-adjusted to the following positions:

S1 Dip Switch No.	1	2	3	4	5	6	7	8	9	10
KM-231BAJ	OFF	OFF	OFF	OFF	ON	ON	OFF	ON	OFF	ON
KM-301BAJ	OFF	OFF	OFF	OFF	ON	ON	ON	OFF	OFF	ON
KM-301BWJ	OFF	OFF	OFF	OFF	ON	ON	ON	OFF	ON	OFF

S2 Dip Switch (Do Not Adjust)						
Dip Switch No.	1	2	3	4	5	6
KM-231BAJ	ON	OFF	OFF	OFF	OFF	ON
KM-301BAJ	ON	OFF	OFF	OFF	OFF	OFF
KM-301BWJ	ON	OFF	OFF	OFF	OFF	OFF

Do not adjust the S2 dip switch. These must be left in the factory default position, or the appliance will not operate properly.

S1 Dip Switch

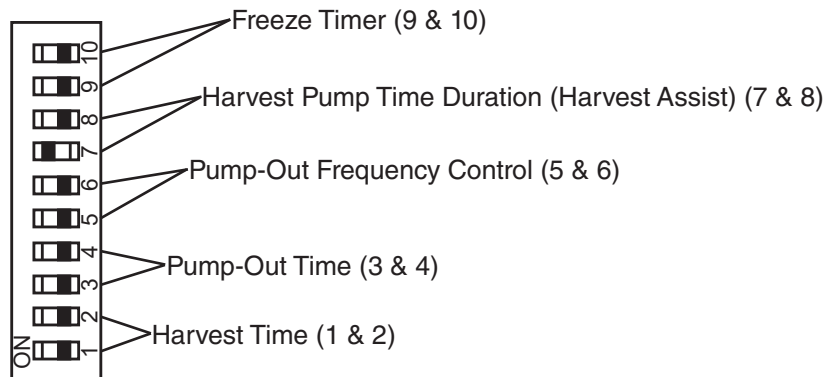

S2 Dip Switch (do not adjust)

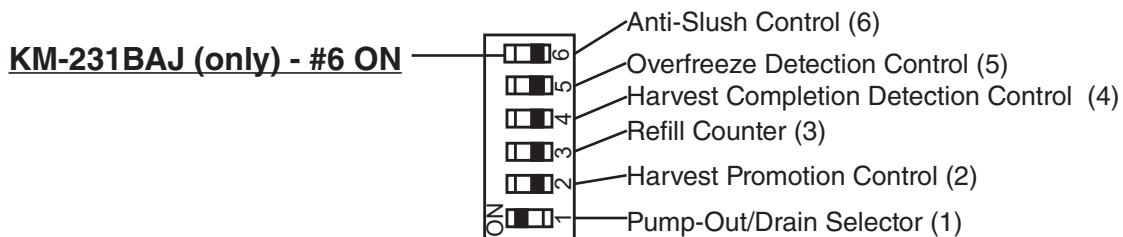

b) Harvest Time (S1 dip switch 1 & 2)

The harvest timer starts counting when the thermistor reaches 48°F (9°C) at the evaporator outlet and the control board reads 3.9 kΩ from the thermistor. The harvest timer is factory set, and generally no adjustment is required. However, a setting longer than the factory setting may be advised in cases where the drain provided at harvest needs to be prolonged for extra cleaning. Note that the pump-out timer (S1 dip switch 3 & 4) acts in place of the harvest timer during cycles with a pump out. For details, see "III.C.3. Pump-Out Timer (S1 dip switch 3 & 4)."

Note: On models with a pump-out every cycle, the harvest timer is only relevant during the initial harvest cycle since a pump out occurs every cycle thereafter.

S1 Dip Switch Setting		Time (sec.)
No. 1	No. 2	
OFF	OFF	60
ON	OFF	90
OFF	ON	120
ON	ON	180

c) Pump-Out Time/Harvest Time During Pump-Out (S1 dip switch 3 & 4)

When a pump-out is called for, the pump motor stops for 2 seconds, then the pump motor and drain valve energize. Water is removed from the bottom of the water tank and sent down the drain. The pump-out drains the water tank for the time determined by the pump-out timer. The pump-out timer also acts in place of the harvest timer during cycles with a pump-out. The pump-out timer is factory set, and generally no adjustment is required. The pump-out timer control can be set to pump-out for 10 or 20 seconds. During pump-out cycles minimum harvest time is based on times given in the table below.

S1 Dip Switch Setting		Time (sec.)	
No. 3	No. 4	T1	T2
OFF	OFF	10	120
ON	OFF	20	160
OFF	ON	20	120
ON	ON	20	180

T1: Time to drain the water tank

T2: Harvest timer at pump out

d) Pump-Out Frequency Control (S1 dip switch 5 & 6)

The pump-out frequency control is factory set to drain the water tank every 10 cycles. Generally no adjustment is required. However, where water quality is bad and the icemaker needs a pump-out more often, the pump-out frequency can be adjusted. The pump-out frequency control can be set to have a pump-out occur every cycle, or every 10 cycles.

The first pump-out is dependent on S1 dip switch 5 & 6. See the table below.

S1 Dip Switch Setting		Pump-Out Frequency
No. 5	No. 6	
OFF	OFF	Every cycle
ON	OFF	Every 2 cycles
OFF	ON	Every 5 cycles
ON	ON	Every 10 cycles

e) Harvest Pump Time Duration (Harvest Assist) (S1 dip switch 7 & 8)

NOTICE
Factory set for proper operation. Do not adjust. Adjustment outside of the factory default setting may result in damage to the appliance.

The harvest pump timer allows the water valve to close and the pump motor to circulate water in the tank during the final part of harvest. The water valve is open during harvest for a maximum of 6 minutes or the length of harvest minus 0, 10, 30, or 50 seconds (determined by the harvest pump timer setting), whichever is shorter. When the water valve closes, the pump motor energizes and runs for the time determined by the harvest pump timer setting. The harvest pump timer is factory-adjusted, and no adjustment is required.

S1 Dip Switch Setting		Harvest Pump Time Duration (Harvest Assist)
No. 7	No. 8	
OFF	OFF	0 sec.
ON	OFF	10 sec.
OFF	ON	30 sec.
ON	ON	50 sec.

f) Freeze Timer (S1 dip switch 9 & 10)

NOTICE

Adjust to proper specification, or the icemaker may not operate correctly.

The freeze timer setting determines the maximum allowed freeze time to prevent possible freeze-up issues. Upon termination of the freeze timer, the control board initiates the harvest cycle or pump-out cycle. After 2 consecutive freeze timer terminations, the control board shuts down the icemaker. In this case, see "II.H.3. Low Ice Production" for possible solutions. The freeze timer is factory set and no adjustment is required. Before changing this setting, contact Hoshizaki Technical Support at 1-800-233-1940 for recommendations.

S1 Dip Switch Setting		Time (min.)
No. 9	No. 10	
OFF	OFF	60
OFF	ON	50
ON	OFF	70
ON	ON	100

g) Pump-Out/Drain Selector (S2 dip switch 1)

The pump-out/drain selector setting determines whether the pump motor energizes (pump-out) or stays off (drain) after a 2-second delay at the beginning of the pump-out cycle or at shutdown. Regardless of the pump-out/drain selector setting, the drain valve energizes after a 2-second delay at the beginning of the pump-out cycle or at shutdown. When the pump-out/drain selector is set to pump-out, the pump motor takes water from the tank and forces it through the drain valve and down the drain. When the pump-out/drain selector is set to drain, water drains by gravity through the drain valve.

S2 Dip Switch Setting	Pump Operation Setting
No. 1	
OFF	Drain
ON	Pump-Out

h) Harvest Promotion Control (S2 dip switch 2)

NOTICE

Do not adjust. These must be left in the factory default position or the icemaker will not operate correctly.

When activated, this control promotes harvest of ice on the evaporator that is hard to remove. If the harvest cycle exceeds 6 minutes, the pump motor starts to operate for a maximum of 3 minutes.

S2 Dip Switch Setting	Harvest Promotion Control
No. 2	
OFF	Enabled
ON	Disabled

i) Minimum Harvest Time (S2 dip switch 3)

NOTICE
Factory set for proper operation. Do not adjust. Adjustment outside the factory default setting may result in damage to the appliance.

Do not adjust. This must be left in the factory default position or the appliance will not operate properly. The KM-231BAJ, KM-301BAJ, and KM-301BWJ do not refill.

j) Harvest Completion Detection Control (S2 dip switch 4)

NOTICE
Factory set for proper operation. Do not adjust. Adjustment outside the factory default setting may result in damage to the appliance.

It is disabled (OFF) on all models.

When enabled (ON), this control determines whether ice remains on the evaporator at the end of a harvest cycle and at the beginning of a freeze cycle. If ice drops and activates the bin control switch in the last 10 seconds of a harvest cycle, the control determines that ice still remains on the evaporator and extends the harvest cycle for 30 seconds. If the bin control switch is activated at the beginning of a freeze cycle, the control determines that ice still remains on the evaporator and starts a harvest cycle after the minimum freeze cycle time has passed.

S2 Dip Switch Setting	Harvest Completion Detection Control
No. 4	
OFF	Disabled
ON	Enabled

k) Overfreeze Detection Control (S2 dip switch 5)

NOTICE

Factory set for proper operation. Do not adjust. Adjustment outside the factory default setting may result in damage to the appliance.

Do not adjust. This must be left in the factory default position or the appliance will not operate properly. It is disabled (OFF) on all models.

When enabled (ON), the thermistor detects the temperature of the evaporator outlet to find overfreeze in a harvest cycle and at the beginning of a freeze cycle. If the difference between the maximum temperature after the harvest pump timer starts counting and the temperature at the end of a harvest cycle is 7.2°F (4°C) or more and if the temperature at the end of a harvest cycle is 48°F (9°C) or less, the harvest cycle is extended for 30 seconds. If the difference between the temperature at the beginning of a freeze cycle and the minimum temperature after 30 seconds in the freeze cycle is 2.5kΩ or more and less than 3.5kΩ, the next harvest cycle is extended for 30 seconds. If the above conditions occur in succession, the number of occurrence times 30 seconds will be added to the harvest cycle time. If the above temperature difference is 3.5kΩ or more, the freeze cycle ends after the minimum freeze cycle time and a harvest cycle starts.

If the evaporator outlet temperature is more than 3.5°C but not more than 5°C at the end of harvest cycle, the harvest cycle is extended for 50 seconds before moving on to the freeze cycle. If the evaporator outlet temperature is 3.5°C or less, another harvest cycle starts. The harvest cycle does not repeat more than three times. The freeze cycle starts even if the evaporator outlet temperature is 3.5°C or less at the end of the third harvest cycle.

S2 Dip Switch Setting	Overfreeze Detection Control
No. 5	
OFF	Disabled
ON	Enabled

I) Anti-Slush Control (S2 dip switch 6)

NOTICE

Factory set for proper operation. Do not adjust. Adjustment outside the factory default setting may result in damage to the appliance.

This dip switch setting allows anti-slush control during the freeze cycle.

Disabled (OFF): When the evaporator temperature reaches 41°F (5°C) the control board reads a 4.8 kΩ signal from the thermistor and de-energizes the water pump for 10 sec., then energizes the water pump for the duration of freeze time.

Enabled (ON): When the evaporator temperature reaches 50°F (10°C) the control board reads a 3.9kΩ signal from the thermistor and de-energizes the water pump for 10 sec. and energize it for 50 secs. repeatedly. When 34°F (1°C) is reached, a 5.9 kΩ signal causes the control board to de-energize the pump motor for 10 secs., energize it for 50 secs., de-energize it again for 10 secs., then energize it continuously.

S2 Dip Switch Setting	Anti-Slush Control
No. 6	
OFF	Disabled
ON	Enabled

2. H+ Control Board (2B0161-01)

a) Default Dip Switch Settings

The dip switches are factory-adjusted to the following positions:

S4 Dip Switch No.	1	2	3	4	5	6	7	8	9	10
KM-231BAJ	OFF	OFF	OFF	OFF	ON	ON	OFF	ON	OFF	ON
KM-301BAJ	OFF	OFF	OFF	OFF	ON	ON	ON	OFF	OFF	ON
KM-301BWJ	OFF	OFF	OFF	OFF	ON	ON	ON	OFF	ON	OFF

S5 Dip Switch (Do Not Adjust)					
Dip Switch No.	1	2	3	4	5
KM-231BAJ					
KM-301BAJ	ON	OFF	OFF	OFF	OFF
KM-301BWJ					

Do not adjust the S5 dip switches. These must be left in the factory default position, or the appliance will not operate properly.

S4 Dip Switch

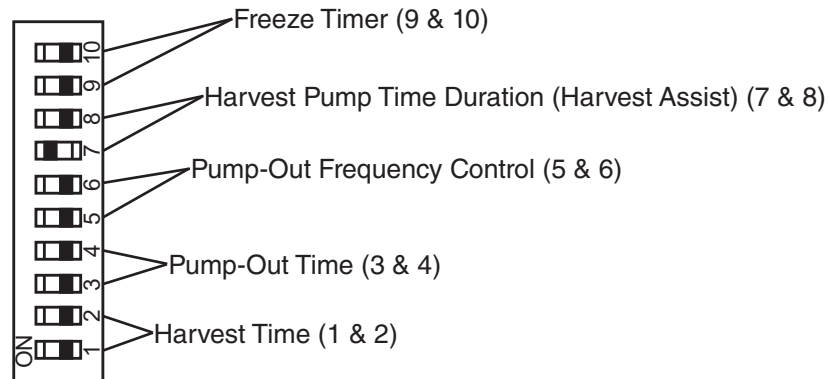

S5 Dip Switch

(Do Not Adjust)

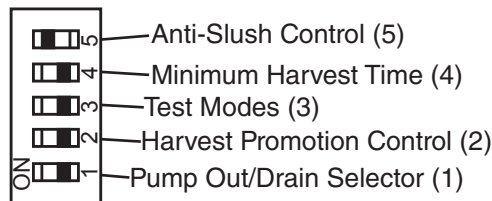

b) Harvest Time (S4 dip switch 1 & 2)

The harvest timer starts counting when the thermistor reaches 48°F (9°C) at the evaporator outlet and the control board reads 3.9 kΩ from the thermistor. The harvest timer is factory set, and generally no adjustment is required. However, a setting longer than the factory setting may be advised in cases where the drain provided at harvest needs to be prolonged for extra cleaning. Note that the pump-out timer (S1 dip switch 3 & 4) acts in place of the harvest timer during cycles with a pump out. For details, see "III.C.3. Pump-Out Timer (S1 dip switch 3 & 4)."

Note: On models with a pump-out every cycle, the harvest timer is only relevant during the initial harvest cycle since a pump out occurs every cycle thereafter.

S4 Dip Switch Setting		Time (sec.)
No. 1	No. 2	
OFF	OFF	60
ON	OFF	90
OFF	ON	120
ON	ON	180

c) Pump-Out Time/Harvest Time During Pump-Out (S4 dip switch 3 & 4)

When a pump-out is called for, the pump motor stops for 2 seconds, then the pump motor and drain valve energize. Water is removed from the bottom of the water tank and sent down the drain. The pump-out drains the water tank for the time determined by the pump-out timer. The pump-out timer also acts in place of the harvest timer during cycles with a pump-out. The pump-out timer is factory set, and generally no adjustment is required. The pump-out timer control can be set to pump-out for 10 or 20 seconds. During pump-out cycles minimum harvest time is based on times given in the table below.

S4 Dip Switch Setting		Time (sec.)	
No. 3	No. 4	T1	T2
OFF	OFF	10	120
ON	OFF	20	160
OFF	ON	20	120
ON	ON	20	180

T1: Time to drain the water tank
T2: Harvest timer at pump out

d) Pump-Out Frequency Control (S4 dip switch 5 & 6)

The pump-out frequency control is factory set to drain the water tank every 10 cycles. Generally no adjustment is required. However, where water quality is bad and the icemaker needs a pump-out more often, the pump-out frequency can be adjusted. The pump-out frequency control can be set to have a pump-out occur every cycle, or every 10 cycles.

The first pump-out is dependent on S1 dip switch 5 & 6. See the table below.

S4 Dip Switch Setting		Pump-Out Frequency
No. 5	No. 6	
OFF	OFF	Every cycle
ON	OFF	Every 2 cycles
OFF	ON	Every 5 cycles
ON	ON	Every 10 cycles

e) Harvest Pump Time Duration (Harvest Assist) (S4 dip switch 7 & 8)

NOTICE
Factory set for proper operation. Do not adjust. Adjustment outside of the factory default setting may result in damage to the appliance.

The harvest pump timer allows the water valve to close and the pump motor to circulate water in the tank during the final part of harvest. The water valve is open during harvest for a maximum of 6 minutes or the length of harvest minus 0, 10, 30, or 50 seconds (determined by the harvest pump timer setting), whichever is shorter. When the water valve closes, the pump motor energizes and runs for the time determined by the harvest pump timer setting. The harvest pump timer is factory-adjusted, and no adjustment is required.

S4 Dip Switch Setting		Harvest Pump Time Duration (Harvest Assist)
No. 7	No. 8	
OFF	OFF	0 sec.
ON	OFF	10 sec.
OFF	ON	30 sec.
ON	ON	50 sec.

f) Freeze Timer (S4 dip switch 9 & 10)

NOTICE
Adjust to proper specification, or the icemaker may not operate correctly.

The freeze timer setting determines the maximum allowed freeze time to prevent possible freeze-up issues. Upon termination of the freeze timer, the control board initiates the harvest cycle or pump-out cycle. After 2 consecutive freeze timer terminations, the control board shuts down the icemaker. In this case, see "II.H.3. Low Ice Production" for possible solutions. The freeze timer is factory set and no adjustment is required. Before changing this setting, contact Hoshizaki Technical Support at 1-800-233-1940 for recommendations.

S4 Dip Switch Setting		Time (min.)
No. 9	No. 10	
OFF	OFF	60
OFF	ON	50
ON	OFF	70
ON	ON	100

g) Pump-Out/Drain Selector (S5 dip switch 1)

The pump-out/drain selector setting determines whether the pump motor energizes (pump-out) or stays off (drain) after a 2-second delay at the beginning of the pump-out cycle or at shutdown. Regardless of the pump-out/drain selector setting, the drain valve energizes after a 2-second delay at the beginning of the pump-out cycle or at shutdown. When the pump-out/drain selector is set to pump-out, the pump motor takes water from the tank and forces it through the drain valve and down the drain. When the pump-out/drain selector is set to drain, water drains by gravity through the drain valve.

S5 Dip Switch Setting	Pump Operation Setting
No. 1	
OFF	Drain
ON	Pump-Out

h) Harvest Promotion Control (S5 dip switch 2)

NOTICE
Do not adjust. These must be left in the factory default position or the icemaker will not operate correctly.

When activated, this control promotes harvest of ice on the evaporator that is hard to remove. If the harvest cycle exceeds 6 minutes, the pump motor starts to operate for a maximum of 3 minutes.

S5 Dip Switch Setting	Harvest Promotion Control
No. 2	
OFF	Enabled
ON	Disabled

i) Test Modes (S5 dip switch 3)

NOTICE
Factory set for proper operation. Do not adjust. Adjustment outside the factory default setting may result in damage to the appliance.

Do not adjust. This must be left in the factory default position or the unit will not operate properly.

j) Minimum Harvest Time (S5 dip switch 4)

NOTICE
Factory set for proper operation. Do not adjust. Adjustment outside the factory default setting may result in damage to the appliance.

S5 Dip Switch Setting	
No. 4	Minimum Harvest Time
OFF	120 seconds
ON	70 seconds

k) Anti-Slush Control (S5 dip switch 5)

NOTICE
Factory set for proper operation. Do not adjust. Adjustment outside the factory default setting may result in damage to the appliance.

This dip switch setting allows anti-slush control during the freeze cycle.

Disabled (OFF): When the evaporator temperature reaches 41°F (5°C) the control board reads a 4.8 kΩ signal from the thermistor and de-energizes the water pump for 10 sec., then energizes the water pump for the duration of freeze time.

Enabled (ON): When the evaporator temperature reaches 50°F (10°C) the control board reads a 3.9kΩ signal from the thermistor and de-energizes the water pump for 10 sec. and energize it for 50 secs. repeatedly. When 34°F (1°C) is reached, a 5.9 kΩ signal causes the control board to de-energize the pump motor for 10 secs., energize it for 50 secs., de-energize it again for 10 secs., then energize it continuously.

S5 Dip Switch Setting	Anti-Slush Control
No. 5	
OFF	Disabled
ON	Enabled

IV. Refrigeration Circuit and Component Service Information

WARNING

- This appliance should be diagnosed and repaired only by qualified service personnel to reduce the risk of death, electric shock, serious injury, or fire.
- Move the control switch to the “OFF” position and turn off the power supply. Place the disconnect in the “OFF” position. Lockout/Tagout to prevent the power supply from being turned back on inadvertently.
- **CHOKING HAZARD:** Ensure all components, fasteners, and thumbscrews are securely in place after the icemaker is serviced. Make sure that none have fallen into the dispenser unit/ice storage bin.
- Make sure all food zones in the icemaker and dispenser unit/ice storage bin are clean after service.

A. Refrigeration Circuit Service Information

WARNING

- Repairs requiring the refrigeration circuit to be opened must be performed by properly trained and EPA-certified service personnel.
- Use an electronic leak detector or soap bubbles to check for leaks. Add a trace of refrigerant to the system (if using an electronic leak detector), and then raise the pressure using nitrogen gas (140 PSIG). Do not use R-404A as a mixture with pressurized air for leak testing.

NOTICE

- Always recover the refrigerant and store it in an approved container. Do not discharge the refrigerant into the atmosphere.
- Do not leave the system open for longer than 15 min. when replacing or servicing parts. The Polyol Ester (POE) oils used in R-404A applications can absorb moisture quickly. Therefore it is important to prevent moisture from entering the system when replacing or servicing parts.
- Always install a new drier every time the sealed refrigeration system is opened.
Do not replace the drier until after all other repair or replacement has been made. Install the new drier with the arrow on the drier in the direction of the refrigerant flow.
- When brazing, protect the drier by using a wet cloth to prevent the drier from overheating. Do not allow the drier to exceed 250°F (121°C).

1. Refrigerant Recovery

The icemaker is provided with refrigerant access valves. Using proper refrigerant practices, recover the refrigerant. Store the refrigerant in an approved container. Do not discharge the refrigerant into the atmosphere.

2. Brazing

WARNING

- R-404A itself is not flammable at atmospheric pressure and temperatures up to 176°F (80°C).
- R-404A itself is not explosive or poisonous. However, when exposed to high temperatures (open flames), R-404A can be decomposed to form hydrofluoric acid and carbonyl fluoride both of which are hazardous.
- Do not use silver alloy or copper alloy containing arsenic.

- 1) Braze all fittings while purging with nitrogen gas flowing at a pressure of 3 to 4 PSIG.
Note: Because the pipes in the evaporator case are specially coated to resist corrosion, it is important to make connections outside the evaporator case when possible. If it is necessary to braze inside the evaporator case, use sandpaper to remove the coating from the brazing connections before debrazing the components.

NOTICE

- Always install a new drier every time the sealed refrigeration system is opened.
- Do not replace the drier until after all other repair or replacement has been made. Install the new drier with the arrow on the drier in the direction of the refrigerant flow.
- When brazing, protect the drier by using a wet cloth to prevent the drier from overheating. Do not allow the drier to exceed 250°F (121°C).

- 2) Use an electronic leak detector or soap bubbles to check for leaks. Add a trace of refrigerant to the system (if using an electronic leak detector), and then raise the pressure using nitrogen gas (140 PSIG). Do not use R-404A as a mixture with pressurized air for leak testing.

3. Evacuation and Recharge (R-404A)

- 1) Attach a vacuum pump to the system. Be sure to connect the charging hoses to both the low-side refrigerant access valve and the field-installed high-side access valve.

IMPORTANT

The vacuum level and vacuum pump may be the same as those for current refrigerants. However, the rubber hose and gauge manifold to be used for evacuation and refrigerant charge should be exclusively for POE oils.

- 2) Turn on the vacuum pump. Open the gauge manifold valves. Never allow the oil in the vacuum pump to flow backwards.
- 3) Allow the vacuum pump to pull down to a 29.9" Hg vacuum. Evacuating period depends on pump capacity.
- 4) Close the low-side valve and high-side valve on the gauge manifold.

- 5) Disconnect the gauge manifold hose from the vacuum pump and attach it to a refrigerant service cylinder. Remember to loosen the connection and purge the air from the hose. For the required refrigerant charge, see the rating label inside the icemaker. Hoshizaki recommends only virgin refrigerant or reclaimed refrigerant which meets ARI Standard 700 (latest edition) be used.
- 6) A liquid charge is required when charging an R-404A system (to prevent fractionation). Place the service cylinder on the scales; if the service cylinder is not equipped with a dip tube, invert the service cylinder, then place it on the scales. Open the high-side valve on the gauge manifold.
- 7) Allow the system to charge with liquid until the proper charge weight is met.
- 8) If necessary, add any remaining charge to the system through the low-side.
NOTICE! To prevent compressor damage, use a throttling valve or liquid dispensing device to add the remaining liquid charge through the low-side refrigerant access valve with the icemaker running.
- 9) Close the high and low-side gauge manifold valves, then disconnect the gauge manifold hoses.
- 10) Cap the refrigerant access valves to prevent a possible leak.

B. Component Service Information

NOTICE

When replacing a component listed below, see the notes to help ensure proper operation.

Component	Notes
Compressor	1 phase: Install a new start capacitor, run capacitor, and start relay.
Thermostatic Expansion Valves	<ul style="list-style-type: none"> • Attach the thermostatic expansion valve bulb to the suction line in the same location as the previous bulb. • The bulb should be between the 10 and 2 o'clock positions on the tube. • Secure the bulb with the clamp and holder, then insulate it.
Hot Gas Valves	<ul style="list-style-type: none"> • Replace the strainer if applicable. • Use copper tube of the same diameter and length when replacing valve lines.
Fan Motor	Install a new capacitor.
Pump Motor	Install a new capacitor.
Thermistor	<ul style="list-style-type: none"> • Attach the new thermistor to the suction line in the same location as the previous thermistor. • The thermistor should be at the 12 o'clock position on the tube. • Smoothly fill the recessed area of the thermistor holder with high thermal conductive type sealant. Hoshizaki America part number 4A0683-01 (Silicone Heat Sink Compound 10-8108 manufactured by GC Electronics), KE-4560 RTV (manufactured by ShinEtsu Silicones), or equivalent are recommended. • Secure the thermistor with the holder, then insulate it. • Be very careful to prevent damage to the leads.

C. Water Regulating Valve Adjustment (water-cooled model)

The water regulating valve is factory set, and generally no adjustment is required. However, when necessary, adjust the water regulator using the following procedure.

- 1) Prepare a thermometer to check the condenser drain temperature. Attach a pressure gauge to the high-side line of the system.
- 2) 5 min. after a freeze cycle starts, confirm that the thermometer reads 104°F to 115°F (40°C to 46°C). If it does not, rotate the adjustment screw by using a flat blade screwdriver until the temperature is in the proper range. See Fig. 7. Next, check that the reference pressure is in the range indicated in the Head Pressure table in the Performance Data section. If it is not in the proper range, verify the refrigerant charge.
- 3) Check that the condenser drain temperature is stable.

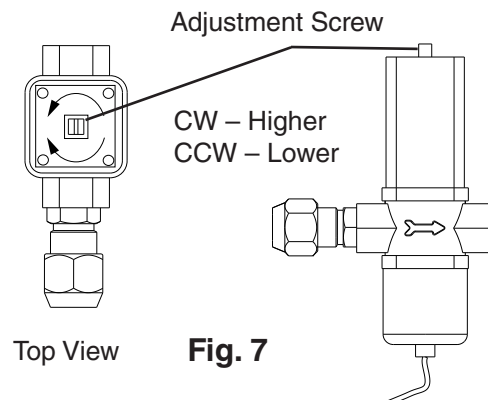

V. Maintenance

The maintenance schedule below is a guideline. More frequent maintenance may be required depending on water quality, the appliance's environment, and local sanitation regulations.

WARNING

- Only qualified service technicians should service the appliance.
- To reduce the risk of electric shock, do not touch the control switch or service switch with damp hands
- Before servicing: Move the control switch to the "OFF" position and unplug the power supply cord from the electrical outlet.
- **CHOKING HAZARD:** Ensure all components, fasteners, and thumbscrews are securely in place after any maintenance is done to the icemaker. Make sure that none have fallen into the dispenser unit/ice storage bin.

Maintenance Schedule

Frequency	Area	Task
Daily	Scoop	Clean the ice scoop using a neutral cleaner. Rinse thoroughly after cleaning.
Bi-Weekly	Air Filters	Inspect. Wash with warm water and neutral cleaner if dirty.
Monthly	External Water Filters	Check for proper pressure and change if necessary.
	Icemaker Exterior	Wipe down with a clean, soft cloth. Use a damp cloth containing a neutral cleaner to wipe off oil or dirt build up. Clean any chlorine staining (rust colored spots) using a non-abrasive cleanser.
	Icemaker Exterior	Wipe down with a clean, soft cloth. Use a damp cloth containing a neutral cleaner to wipe off oil or dirt build up. Clean any chlorine staining (rust colored spots) using a non-abrasive cleanser.
Yearly	Icemaker and Ice Storage Bin Liner	Clean and sanitize per the cleaning and sanitizing instructions provided in the instruction manual or maintenance label on the icemaker.
	Water Supply Inlet	Close the icemaker water supply line shut-off valve and drain the water system. Clean the water supply inlet screen.
	Condenser	Inspect. Clean if necessary by using a brush or vacuum cleaner. More frequent cleaning may be required depending on location.
	Water Hoses	Inspect the water hoses and clean/replace if necessary.

VI. Preparing the Appliance for Periods of Non-Use

NOTICE

- When storing the appliance for an extended time or in sub-freezing temperatures, follow the instructions below to prevent damage.
- To prevent damage to the water pump, do not operate the appliance with the control switch in the “SERVICE” position when the water tank is empty.

When the appliance is not used for two or three days under normal conditions, it is sufficient to move the control switch to the “OFF” position. When storing the appliance for an extended time or in sub-freezing temperatures, follow the instructions below.

1. Remove the water from the icemaker water line:

- 1) Remove the louver, then move the control switch to the “OFF” position. Wait 3 min.
- 2) Close the icemaker water supply line shut-off valve and open the icemaker water supply line drain valve.
- 3) Allow the line to drain by gravity.
- 4) Attach a compressed air or carbon dioxide supply to the icemaker water supply line drain valve.
- 5) Make sure at least 3 min. have elapsed. Move the control switch to the “ICE” position.
- 6) Blow the icemaker water supply line out using the compressed air or carbon dioxide supply.
- 7) Close the icemaker water supply line drain valve.

2. Remove the water from the water tank:

- 1) Move the service switch to the “DRAIN” position, then move the control switch to the “SERVICE” position. Allow the water tank to drain completely.
- 2) After all of the water has drained, move the control switch to the “OFF” position, then unplug the icemaker from the electrical outlet.
- 3) Remove all ice from the ice storage bin. Clean the storage bin liner using a neutral cleaner. Rinse thoroughly after cleaning.

3. On water-cooled model, remove the water from the water-cooled condenser:

- 1) Make sure the appliance is unplugged and the control switch is in the "OFF" position.
- 2) Close the condenser water supply line shut-off valve. If connected to a closed loop system, also close the condenser return line shut-off valve.
- 3) Open the condenser water supply line drain valve. If connected to a closed loop system, also open the condenser return line drain valve.
- 4) Attach a compressed air or carbon dioxide supply to the condenser water supply line drain valve.
- 5) Open the water regulating valve by using a screwdriver to pry up on the spring retainer underneath the spring. While holding the valve open, blow out the condenser using the compressed air or carbon dioxide supply until water stops coming out.
- 6) Close the drain valve(s).
- 7) Replace the right side panel and front panel in their correct positions.

VII. Disposal

The appliance contains refrigerant and must be disposed of in accordance with applicable national, state, and local codes and regulations. Refrigerant must be recovered by properly certified service personnel.

VIII. Technical Information

We reserve the right to make changes in specifications and design without prior notice.

A. Specification and Performance Data Sheets

Pressure data is recorded at 5 min. into freezing cycle. The data not in bold should be used for reference only.

1. KM-231BAJ

Specification Sheet

AC SUPPLY VOLTAGE	115/60/1	
AMPERAGE	7.1 A (5 Min. Freeze At 104°F / WT 80°F)	
MINIMUM CIRCUIT AMPACITY	15 A	
MAXIMUM FUSE SIZE	15 A	
ELECTRIC & WATER CONSUMPTION	90/70°F	70/50°F
ELECTRIC W (kWH/100 lbs.)	520 (8.40)	490 (5.50)
WATER gal./24HR (gal./100 lbs.)	35 (23.5)	58 (27.1)
ICE PRODUCTION PER CYCLE	3.3 lbs. (1.5 kg) 182pcs.	
APPROXIMATE STORAGE CAPACITY	80 LBS.	
BIN CONTROL SYSTEM	Mechanical Bin Control	
REFRIGERANT CHARGE	R404A, 0 lb. 11.3 oz. (320g)	

Performance Data Sheet

APPROXIMATE ICE PRODUCTION PER 24 HR.	AMBIENT TEMP. (°F/°C)	WATER TEMP. (°F/°C)					
		50/10		70/21		90/32	
	70/21	213	<u>96</u>	194	<u>88</u>	168	<u>76</u>
	80/27	198	<u>90</u>	168	<u>76</u>	143	<u>65</u>
	90/32	194	<u>88</u>	147	<u>67</u>	121	<u>55</u>
lbs./day kg./day	100/38	189	<u>86</u>	141	<u>64</u>	98	<u>44</u>
APPROXIMATE ELECTRIC CONSUMPTION	70/21	490		499		517	
	80/27	497		510		532	
	90/32	499		520		541	
watts	100/38	505		525		560	
APPROXIMATE WATER CONSUMPTION PER 24 HR.	70/21	58	<u>0.22</u>	51	<u>0.19</u>	45	<u>0.17</u>
	80/27	52	<u>0.20</u>	42	<u>0.16</u>	39	<u>0.15</u>
	90/32	51	<u>0.19</u>	35	<u>0.13</u>	30	<u>0.11</u>
gal./day m ³ /day	100/38	42	<u>0.16</u>	34	<u>0.13</u>	26	<u>0.10</u>
FREEZING CYCLE TIME	70/21	22		24		29	
	80/27	24		27		32	
	90/32	24		30		34	
min.	100/38	26		31		39	
HARVEST CYCLE TIME	70/21	2.4		2.3		2.3	
	80/27	2.3		2.1		2.2	
	90/32	2.3		2.0		2.0	
min.	100/38	2.2		2.0		2.0	
HEAD PRESSURE	70/21	223	<u>15.7</u>	243	<u>17.1</u>	260	<u>18.2</u>
	80/27	238	<u>16.7</u>	268	<u>18.9</u>	280	<u>19.7</u>
	90/32	243	<u>17.1</u>	290	<u>20.4</u>	304	<u>21.4</u>
PSIG kg/cm ² G	100/38	243	<u>17.1</u>	293	<u>20.6</u>	317	<u>22.3</u>
SUCTION PRESSURE	70/21	49	<u>3.4</u>	50	<u>3.5</u>	51	<u>3.6</u>
	80/27	50	<u>3.5</u>	52	<u>3.6</u>	52	<u>3.7</u>
	90/32	50	<u>3.5</u>	53	<u>3.7</u>	54	<u>3.8</u>
PSIG kg/cm ² G	100/38	50	<u>3.5</u>	53	<u>3.7</u>	54	<u>3.8</u>
TOTAL HEAT OF REJECTION FROM CONDENSER	3,750 BTU/h [AT 90°F (32°C) / WT 70°F (21°C)]						
TOTAL HEAT OF REJECTION FROM COMPRESSOR	620 BTU/h [AT 90°F (32°C) / WT 70°F (21°C)]						

2. KM-301BAJ

Specification Sheet

AC SUPPLY VOLTAGE	115/60/1
AMPERAGE	8.4 A (5 Min. Freeze AT 104°F / WT 80°F)
MINIMUM CIRCUIT AMPACITY	15 A
MAXIMUM FUSE SIZE	15 A
ELECTRIC & WATER CONSUMPTION	90/70°F 70/50°F
ELECTRIC W (kWH/100 lbs.)	630 (7.10) 670 (5.55)
WATER gal./24HR (gal./100 lbs.)	47 (22.0) 71 (24.6)
ICE PRODUCTION PER CYCLE	4.6 lbs. (2.1 kg) 238pcs.
APPROXIMATE STORAGE CAPACITY	100 LBS.
BIN CONTROL SYSTEM	Mechanical Bin Control
REFRIGERANT CHARGE	R404A, 0 lb. 13.4 oz. (380g)

Performance Data Sheet

APPROXIMATE ICE PRODUCTION PER 24 HR.	AMBIENT TEMP. (°F/°C)	WATER TEMP. (°F/°C)					
		50/10		70/21		90/32	
	70/21	290	<u>131</u>	267	<u>121</u>	247	<u>112</u>
	80/27	272	<u>123</u>	237	<u>107</u>	223	<u>101</u>
	90/32	267	<u>121</u>	212	<u>96</u>	195	<u>88</u>
lbs./day <u>kg./day</u>	100/38	267	<u>121</u>	208	<u>94</u>	179	<u>81</u>
APPROXIMATE ELECTRIC CONSUMPTION	70/21	670		658		686	
	80/27	661		643		694	
	90/32	658		630		672	
watts	100/38	678		640		710	
APPROXIMATE WATER CONSUMPTION PER 24 HR.	70/21	71	<u>0.27</u>	64	<u>0.24</u>	57	<u>0.22</u>
	80/27	66	<u>0.25</u>	54	<u>0.21</u>	50	<u>0.19</u>
	90/32	64	<u>0.24</u>	47	<u>0.18</u>	41	<u>0.16</u>
gal./day <u>m³/day</u>	100/38	55	<u>0.21</u>	45	<u>0.17</u>	36	<u>0.14</u>
FREEZING CYCLE TIME	70/21	21		23		27	
	80/27	23		26		30	
	90/32	23		29		32	
min.	100/38	24		30		35	
HARVEST CYCLE TIME	70/21	2.4		2.3		2.3	
	80/27	2.3		2.1		2.2	
	90/32	2.3		2.0		2.0	
min.	100/38	2.2		2.0		2.0	
HEAD PRESSURE	70/21	219	<u>15.4</u>	234	<u>16.4</u>	249	<u>17.5</u>
	80/27	230	<u>16.2</u>	254	<u>17.8</u>	266	<u>18.7</u>
	90/32	234	<u>16.4</u>	270	<u>19.0</u>	284	<u>19.9</u>
PSIG <u>kg/cm²G</u>	100/38	235	<u>16.5</u>	273	<u>19.2</u>	296	<u>20.8</u>
SUCTION PRESSURE	70/21	45	<u>3.2</u>	46	<u>3.2</u>	48	<u>3.4</u>
	80/27	46	<u>3.2</u>	47	<u>3.3</u>	49	<u>3.5</u>
	90/32	46	<u>3.2</u>	48	<u>3.4</u>	50	<u>3.5</u>
PSIG <u>kg/cm²G</u>	100/38	46	<u>3.3</u>	48	<u>3.4</u>	52	<u>3.7</u>
TOTAL HEAT OF REJECTION FROM CONDENSER	4,200 BTU/h [AT 90°F (32°C) / WT 70°F (21°C)]						
TOTAL HEAT OF REJECTION FROM COMPRESSOR	750 BTU/h [AT 90°F (32°C) / WT 70°F (21°C)]						

3. KM-301BWJ

Specification Sheet

AC SUPPLY VOLTAGE	115/60/1	
AMPERAGE	5.7 A (5 Min. Freeze AT 104°F / WT 80°F)	
MINIMUM CIRCUIT AMPACITY	15 A	
MAXIMUM FUSE SIZE	15 A	
ELECTRIC & WATER CONSUMPTION	90/70°F	70/50°F
ELECTRIC W (kWH/100 lbs.)	480 (4.90)	490 (4.16)
WATER gal./24HR (gal./100 lbs.)	47 (20.0)	54 (18.9)
WATER COOLED CONDENSER	218 (92)	105 (37)
gal./24HR (gal./100 lbs.)		
ICE PRODUCTION PER CYCLE	4.9 lbs. (2.2 kg) 238pcs.	
APPROXIMATE STORAGE CAPACITY	100 LBS.	
BIN CONTROL SYSTEM	Mechanical Bin Control	
REFRIGERANT CHARGE	R404a, 0 lb. 12.3 oz. (350g)	

Performance Data Sheet

APPROXIMATE ICE PRODUCTION PER 24 HR.	AMBIENT TEMP. (°F/°C)	WATER TEMP. (°F/°C)					
		50/10		70/21		90/32	
	70/21	285	<u>129</u>	271	<u>123</u>	210	<u>95</u>
	80/27	274	<u>124</u>	253	<u>115</u>	168	<u>76</u>
	90/32	271	<u>123</u>	237	<u>108</u>	161	<u>73</u>
lbs./day kg./day	100/38	244	<u>111</u>	220	<u>100</u>	92	<u>42</u>
APPROXIMATE ELECTRIC CONSUMPTION	70/21	490		487		494	
	80/27	488		483		496	
	90/32	487		480		490	
watts	100/38	492		482		500	
APPROXIMATE WATER CONSUMPTION PER 24 HR.	70/21	159	<u>0.60</u>	190	<u>0.72</u>	188	<u>0.71</u>
	80/27	182	<u>0.69</u>	231	<u>0.87</u>	204	<u>0.77</u>
	90/32	190	<u>0.72</u>	265	<u>1.00</u>	249	<u>0.94</u>
gal./day m ³ /day	100/38	218	<u>0.82</u>	261	<u>0.99</u>	234	<u>0.89</u>
FREEZING CYCLE TIME	70/21	23		24		27	
	80/27	23		25		29	
	90/32	24		27		30	
min.	100/38	25		28		33	
HARVEST CYCLE TIME	70/21	2.1		2.1		2.1	
	80/27	2.1		2.1		2.1	
	90/32	2.1		2.0		2.0	
min.	100/38	2.1		2.0		2.0	
HEAD PRESSURE	70/21	289	<u>20.3</u>	286	<u>20.1</u>	287	<u>20.2</u>
	80/27	287	<u>20.2</u>	283	<u>19.9</u>	287	<u>20.1</u>
	90/32	286	<u>20.1</u>	280	<u>19.7</u>	283	<u>19.9</u>
PSIG kg/cm ² G	100/38	288	<u>20.3</u>	281	<u>19.7</u>	285	<u>20.0</u>
SUCTION PRESSURE	70/21	49	<u>3.4</u>	49	<u>3.5</u>	39	<u>2.8</u>
	80/27	49	<u>3.5</u>	50	<u>3.5</u>	34	<u>2.4</u>
	90/32	49	<u>3.5</u>	50	<u>3.5</u>	36	<u>2.6</u>
PSIG kg/cm ² G	100/38	44	<u>3.1</u>	47	<u>3.3</u>	24	<u>1.7</u>
TOTAL HEAT OF REJECTION FROM CONDENSER	4,050 BTU/h [AT 90°F (32°C) / WT 70°F (21°C)]						
TOTAL HEAT OF REJECTION FROM COMPRESSOR	700 BTU/h [AT 90°F (32°C) / WT 70°F (21°C)]						

B. Wiring Diagram

1. H Control Board - (P01771-02)

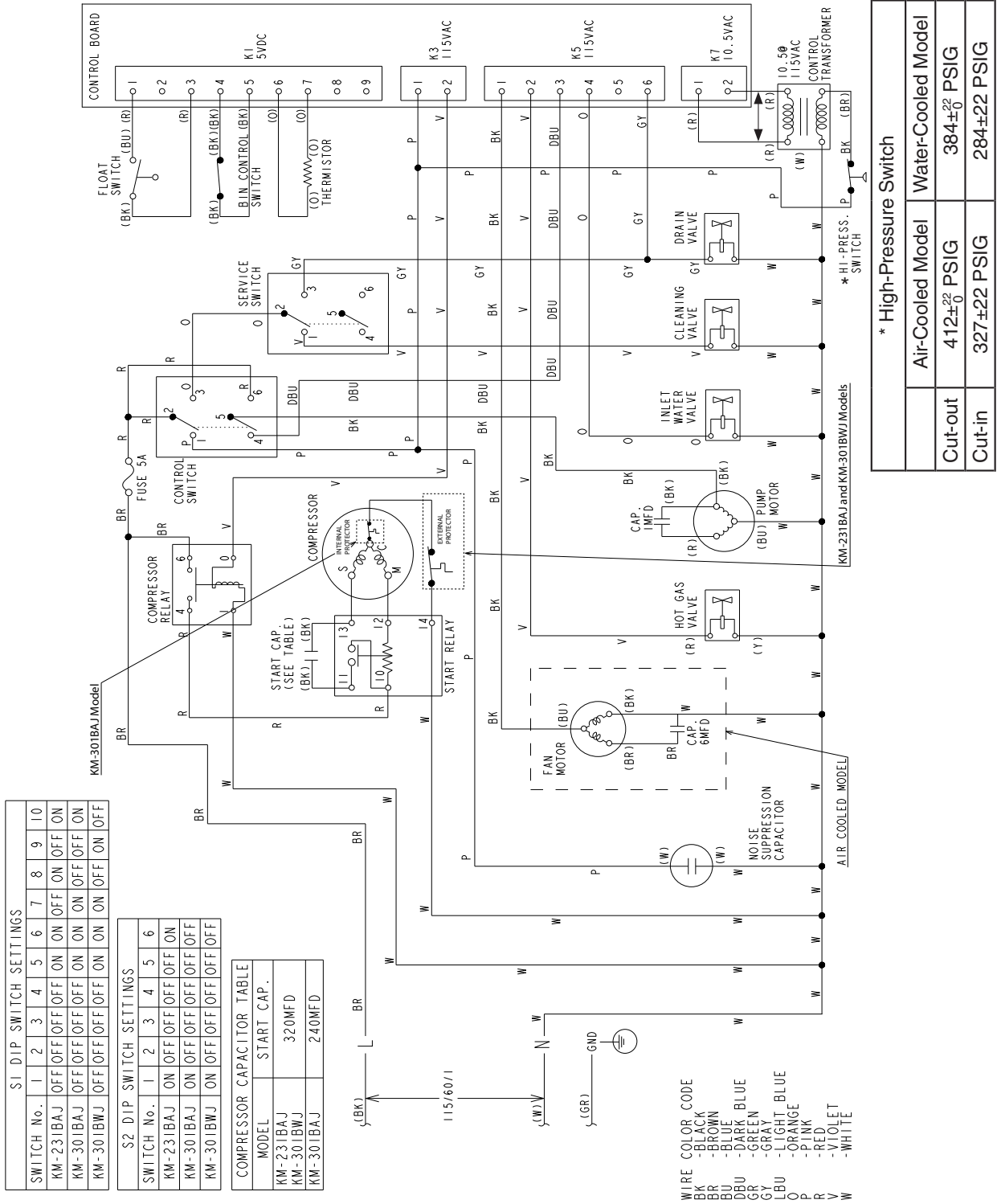

2. H+ Control Board - (2B0161-01)

S4 DIP SWITCH SETTINGS

SWITCH No.	1	2	3	4	5	6	7	8	9	10
KM-231BAJ	OFF	OFF	OFF	OFF	ON	ON	OFF	ON	OFF	ON
KM-301BAJ	OFF	OFF	OFF	OFF	ON	ON	ON	OFF	OFF	ON
KM-301BWJ	OFF	OFF	OFF	OFF	ON	ON	ON	OFF	ON	OFF

S5 DIP SWITCH SETTINGS

SWITCH No.	1	2	3	4	5
KM-231BAJ	ON	OFF	OFF	OFF	OFF
KM-301BAJ	ON	OFF	OFF	OFF	OFF
KM-301BWJ	ON	OFF	OFF	OFF	OFF

COMPRESSOR CAPACITOR TABLE

MODEL	START CAP.
KM-231BAJ	320MFD
KM-301BWJ	240MFD

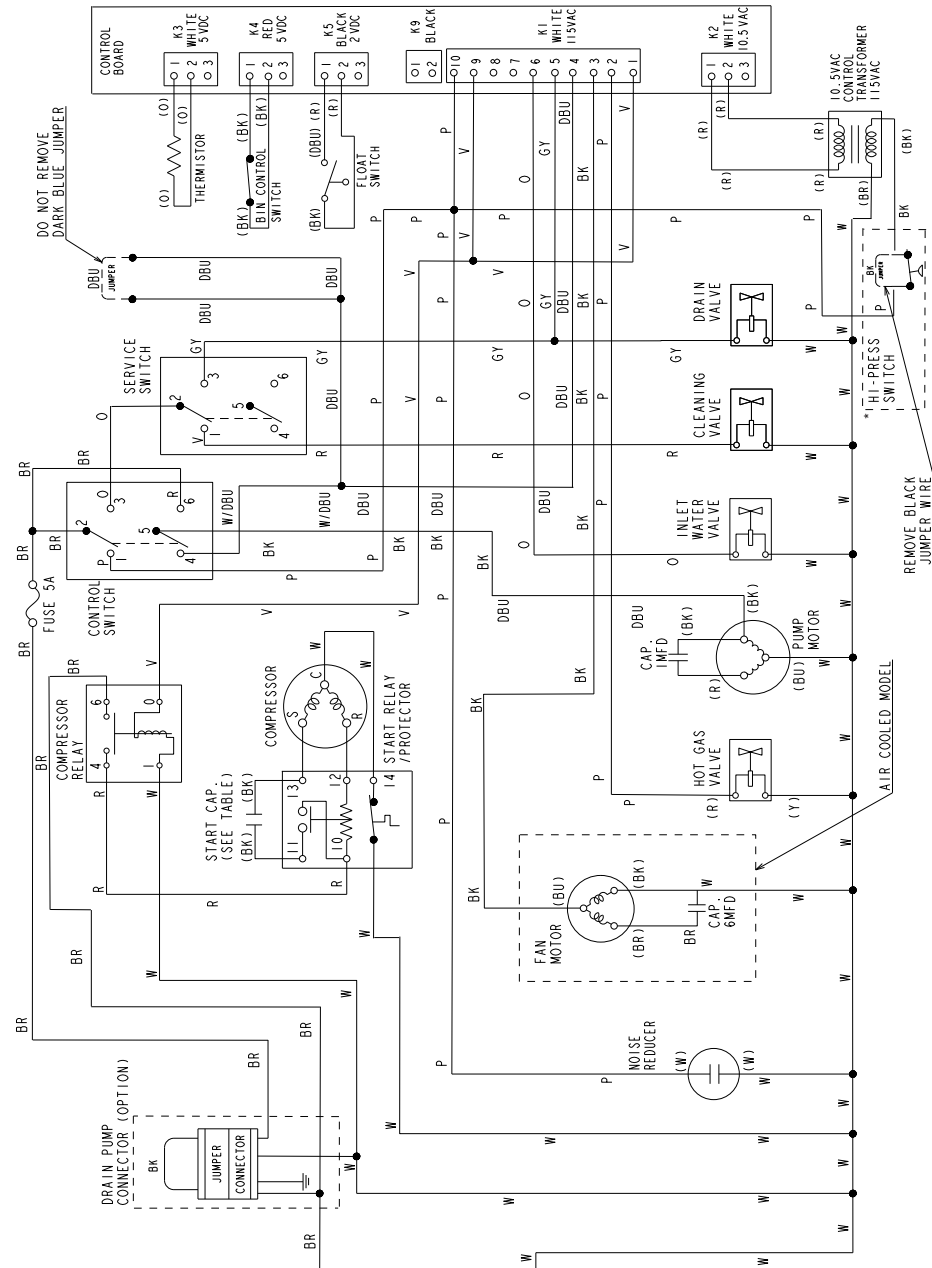

WIRE COLOR CODE
 BK -BLACK
 BR -BROWN
 BU -BLUE
 DBU -DARK BLUE
 GR -GREEN
 GY -GRAY
 LBU -LIGHT BLUE
 O -ORANGE
 P -PINK
 R -RED
 V -VIOLET
 W -WHITE
 W/DBU -WHITE/DARK BLUE

* High-Pressure Switch

Air-Cooled Model	Water-Cooled Model
Cut-out 412±22 PSIG	384±22 PSIG
Cut-in 327±22 PSIG	284±22 PSIG