

FNS 7794 E

PerfectCool freezer

with NoFrost and 8 freezer drawers on telescopic runners for max. convenience.



- Ice cubes thanks to the plumbed IceMaker
- Double the convenience with Miele's Ice&PizzaBox
- No icing up of food and no need to defrost thanks to NoFrost
- Optimum and maintenance-free LED lighting in compartment
- Soft closing of the door with SoftClose

EAN: 4002516480938 / Material number: 11911910 / Old Material Number: 37779400USA

Appliance category	
Freezer	•
Design	
Built-in	•
Built-in integrated	•
Door hinge side	Left
Convertible hinging	•
Can be installed side-by-side	•
Design	
Freezer compartment lighting	LED
IceMaker lighting	•
User convenience	
Networking with Miele@home	•
NoFrost	•
VarioRoom	•
SoftClose door closing damper	•
IceMaker with plumbed water connection	•
Control	
Electronic temperature display and control	FreshTouch
Independent temperature control of fridge and freezer compartments	No
SuperFrost	•
No. of temperature zones	1
Sabbath mode	•
Party mode	•
Freezer/freezer zone	
Number of freezer drawers	8
of which on runners	6
of which Ice&PizzaBox	2
Safety	
Lock function	•
Acoustic door alarm	•
Acoustic temperature alarm, freezer section	•
Acoustic temperature alarm	•
Optical door alarm	•
Optical temperature alarm	•
Power cut indication for freezer compartment	•
Technical data	
Niche width in inches (mm), min.	22 1/8 (560)
Niche width in inches (mm), max.	22 1/2 (570)
Niche height in inches (mm), min.	69 7/8 (1772)
Niche height in inches (mm), max.	70 1/2 (1788)
Niche depth in in.(mm)	21 3/4 (550)
Appliance width in in.(mm)	22 1/8 (559)
Appliance height in in.(mm)	69 3/4 (1770)
Appliance depth in in.(mm)	21 1/2 (544)
Weight in lbs.(kg)	157 (70.9)
Type of mounting	Fixed door
Maximum fridge compartment door front weight in lbs. (kg)	58 (26)

FNS 7794 E

PerfectCool freezer

with NoFrost and 8 freezer drawers on telescopic runners for max. convenience.



EAN: 4002516480938 / Material number: 11911910 / Old Material Number: 37779400USA

Maximum freezer compartment door front weight in lbs. (kg)	58 (26)
--	---------

Climatic classification	SN-T
-------------------------	------

Storage time in case of fault in h	9
------------------------------------	---

Current consumption in milliampere (mA)	0
---	---

Voltage in V	120
--------------	-----

Fuse rating in A	10
------------------	----

Number of phases	1
------------------	---

Frequency in Hz	50-60
-----------------	-------

Wire length in ft (m)	7 (2.2)
-----------------------	---------

Replacing bulbs	Customer Service
-----------------	------------------

FNS 7794 E PerfectCool freezer

with NoFrost and 8 freezer drawers on telescopic runners for max. convenience.

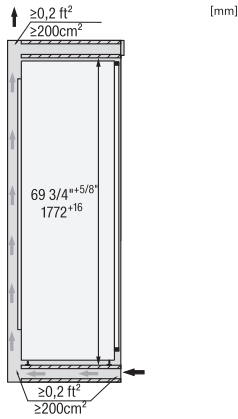

KS7793D, FNS7794E, side view (installation drawings) (US)

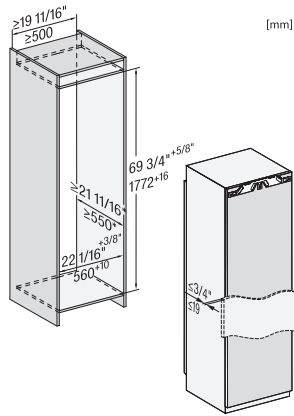

KS7793D, FNS7794E, built-in installation (*footnote) (installation drawings) (US)

*The declared energy consumption was calculated in a 560 mm deep niche. The appliance is fully functional in a 550 mm niche but the energy consumption will be slightly higher.

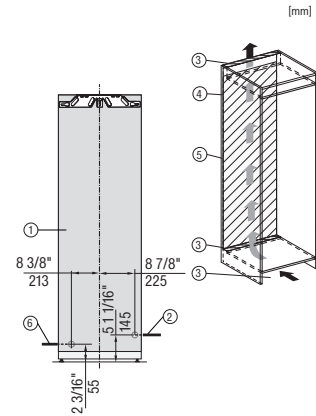

FNS7794E, installation (*footnote) (installation drawings) (US)

*1. View from the front, 2. Mains connection cable, L = 2100 mm, 3. Ventilation cut-out min. 200 cm², 4. Ventilation, 5. No connections permitted in this area, 6. Water connection L = 2000 mm