

ASSEMBLY INSTRUCTION









MODEL# BD02721EK





Thank you for purchasing this quality product. Be sure to check all packing material carefully for small parts which may have come loose inside the carton during shipment. Separate, identify and count all parts and hardware. Compare with the part list to be sure all parts are present. If any part(s) are missing or damaged, please contact your local furniture dealer. For efficient and speedy service, please indicate the model number and code letter of part(s) needed”

"DO NOT TIGHTEN SCREWS UNTIL COMPLETELY ASSEMBLED"

IMPORTANT:

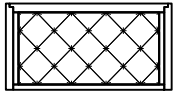
PLEASE READ INSTRUCTION BEFORE STARTING THE ASSEMBLY

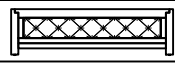
| HARDWARE LIST | | | | |
|---------------|---------------|---|-----------|-------|
| ITEM | DESCRIPTION | DRAWING | SIZE | QTY |
| A | JCBB SCREW |  | M8 x 16MM | 8 PCS |
| B | JCBB SCREW |  | M8 x 40MM | 8 PCS |
| C | JCBC SCREW |  | M6 x 35MM | 8 PCS |
| D | SPRING WASHER |  | M8 x 14MM | 8 PCS |
| E | FLAT WASHER |  | M8 x 22MM | 8 PCS |
| F | CSK SCREW |  | M4 x 32MM | 8 PCS |
| G | L-KEY |  | M4 x 60MM | 1 PC |
| H | L-KEY |  | M5 x 65MM | 1 PC |

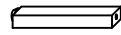
| PART LIST | | | |
|-----------|------------------|---|-------|
| ITEM | DESCRIPTION | DRAWING | QTY |
| 1 | HEADBOARD |  | 1 PC |
| 2 | HEADBOARD LEG(R) |  | 1 PC |
| 3 | HEADBOARD LEG(L) |  | 1 PC |
| 4 | FOOTBOARD |  | 1 PC |
| 5 | SIDE RAIL |  | 2 PCS |
| 6 | SLAT |  | 4 PCS |
| 7 | SUPPORT LEG |  | 8 PCS |

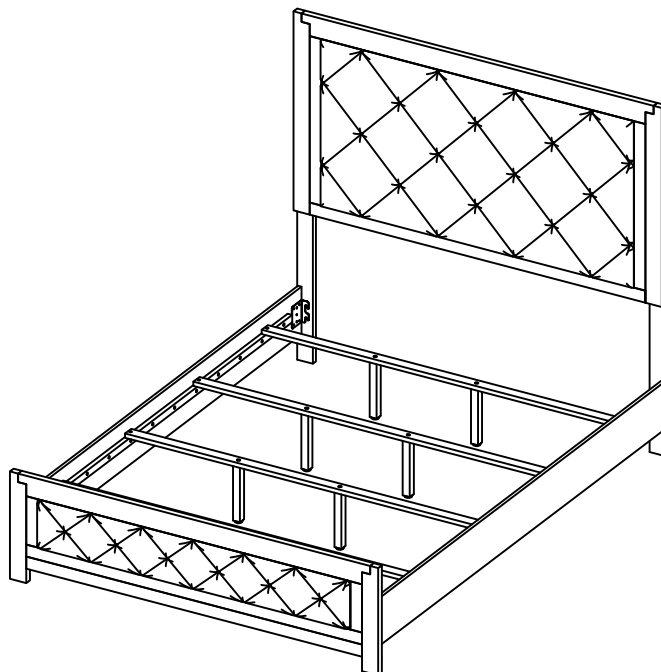

Attention

*** Some number parts listed on the instruction sheet may not be in parts bag as they may already be assembled. Carefully check parts and packing materials prior to ordering replacements.

ASSEMBLY INSTRUCTION

MODEL# BD02721EK

STEP 1

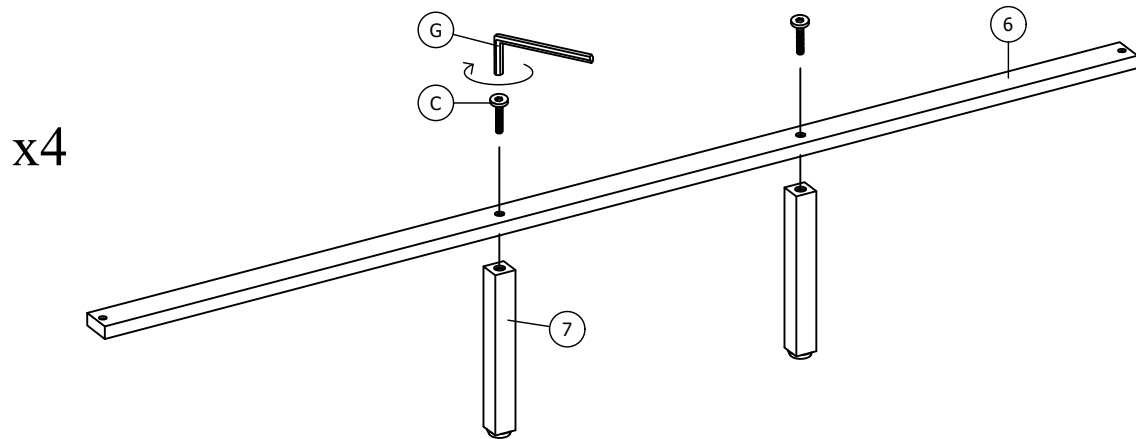

STEP 2

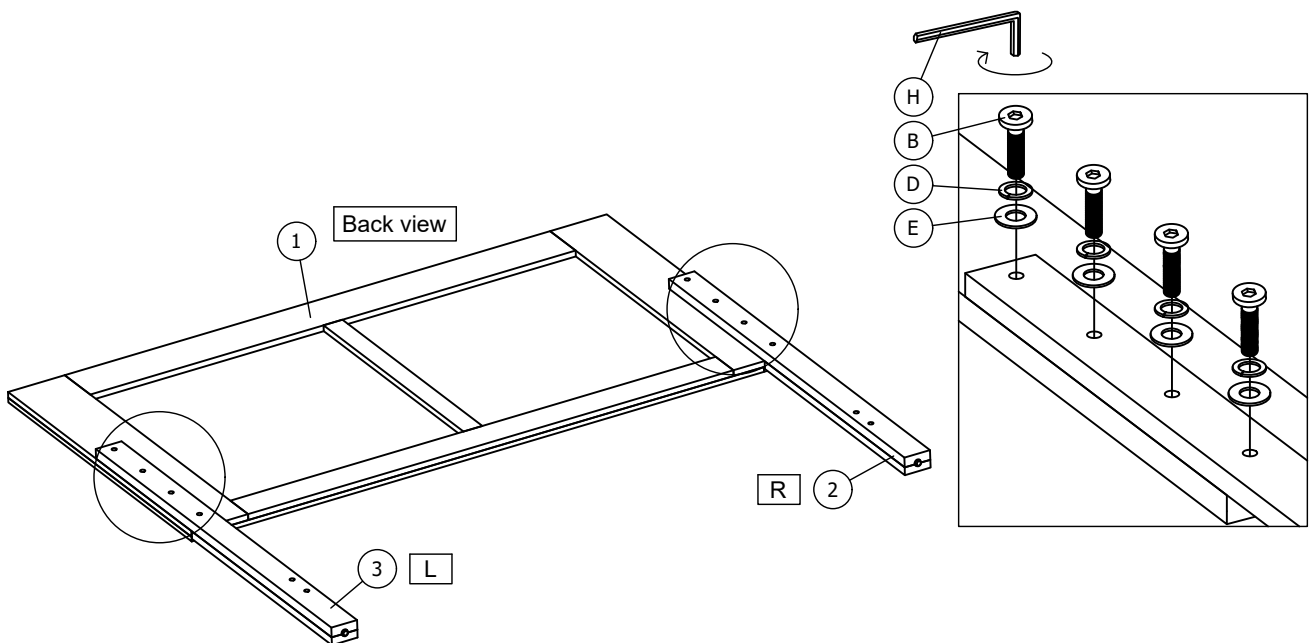

ASSEMBLY INSTRUCTION

MODEL# BD02721EK

STEP 3

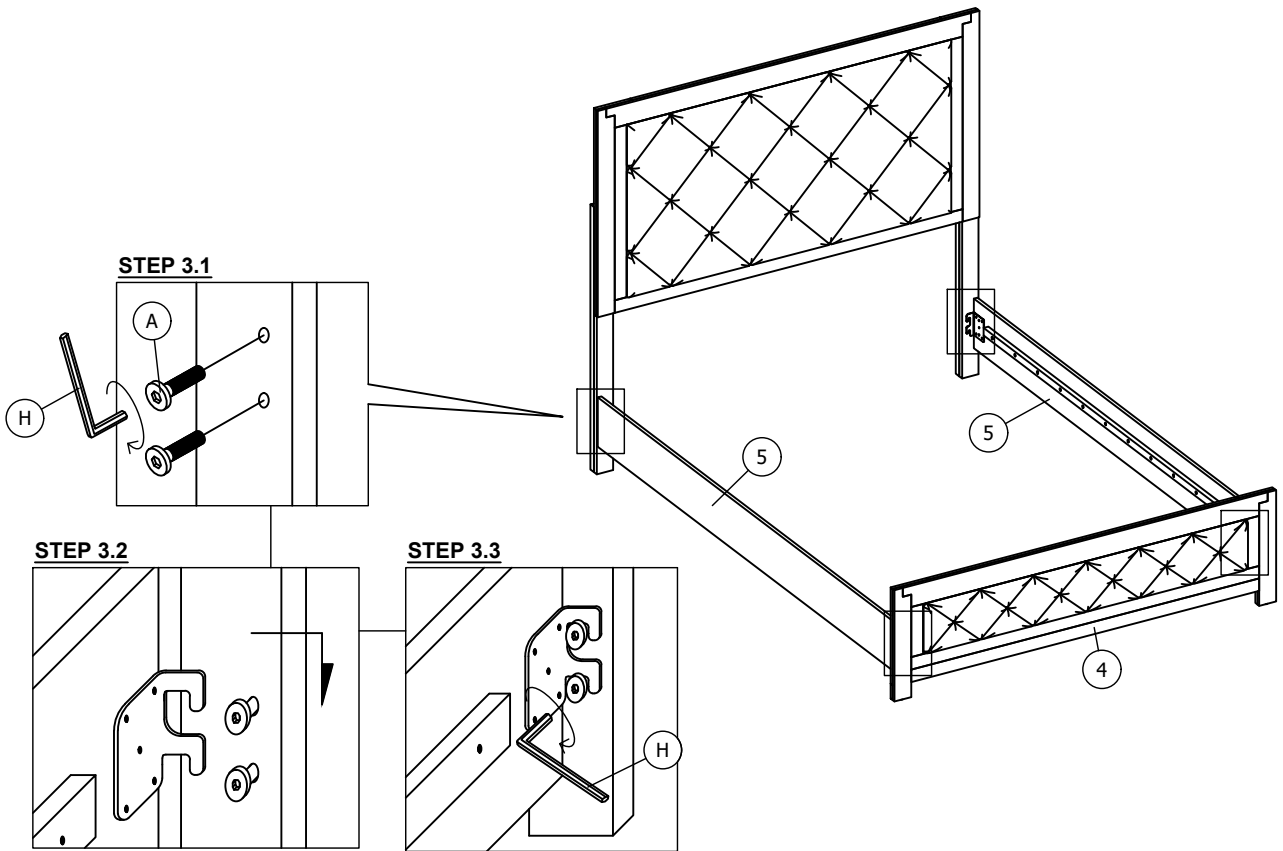

STEP 4

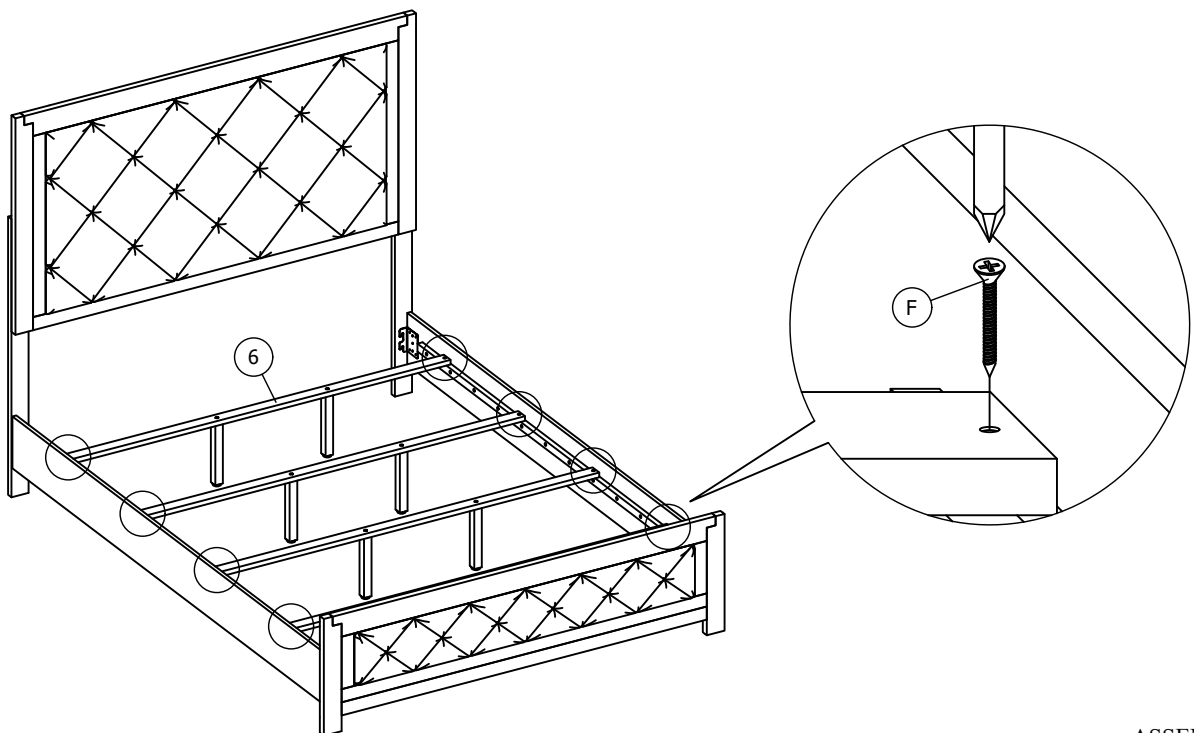

ASSEMBLY
COMPLETED