



OVERVIEW

With timeless Contemporary styling, the Convection Speed Oven fits seamlessly into any kitchen. As a companion product, this Speed Oven is designed to install easily and fit perfectly with other companion products such as the Combination Steam Oven, or Vacuum Seal Drawer. A flexible appliance that pairs the speed of microwave cooking with oven technology, which can crisp and brown as it cooks. Featuring 22 cooking functions on an intuitive touch display for easy programming of desired cooking mode and duration.

PRODUCTS

OM30NDTDB1

Convection Speed Oven, 30", 22 Function

SERIES & STYLE

Series 9
Minimal

FEATURES

- ① Contemporary style, designed to fit flush with cabinetry
- ② 1.7cu ft total capacity
- ③ Intuitive, large 5" touchscreen display with illuminated dial
- ④ With 22 functions: four microwave, 14 oven and four combination
- ⑤ A Wired Temperature Sensor precisely monitors cooking in real time
- ⑥ Guided cooking, with the option to access additional functionality via the SmartHQ™ app
- ⑦ Wi-Fi/Connected capability
- ⑧ Soft open and close door

ACCESSORIES

- ① Chromed shelf runners*
- ② Glass tray*
- ③ Wire shelf*
- ④ Wired Temperature Sensor*

*Included with product



The models shown in this Planning Guide may not be available in all markets and are subject to change at any time. Product specifications may vary from those shown. This Planning Guide should not be used as installation guidance for any product. Further information is required to safely and correctly install the products featured here. Specific installation guidance will be available on our website fisherpaykel.com

SPECIFICATIONS

Model No.	OS30NDTDB1, Combination Steam Oven OM30NDTDB1, Convection Speed Oven
Dimensions	H 18" W 29 15/16" D 22 1/4"
Total Oven Capacity	
OS30NDTDB1	1.9cu ft (55L)
OM30NDTDB1	1.7cu ft (49L)
Weight	
Packaged	121lb (55kg)
Unpackaged	101lb (46kg)
Electrical	
Supply	208 V or 240 V, 60 Hz
Service	20 A

PRODUCT DIMENSIONS

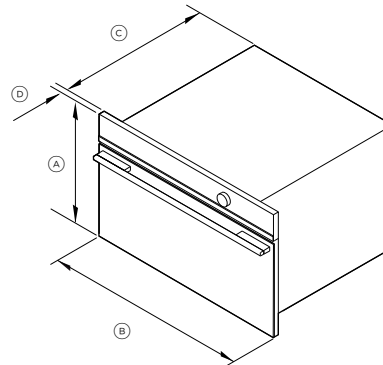

ISO VIEW

	inch	mm
(A) Overall height	18	458
(B) Overall width	29 15/16	760
(C) Depth of chassis	21 7/16	545
(D) Thickness of oven front and control panel (excl. handle and dials)	13/16	20
Depth of door when fully open (measured from front of control panel)	12 5/8	320

CAVITY DIMENSIONS: STANDARD INSTALLATION

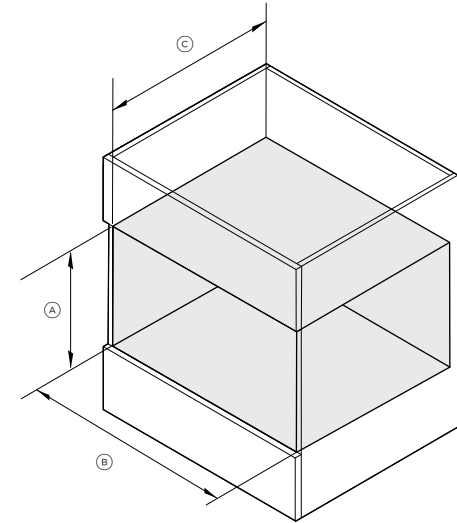

ISO VIEW

	inch	mm
(A) Minimum inside height of cavity	17 5/16	440
(B) Minimum inside width of cavity	28 1/2	724
(C) Minimum inside depth of cavity for flush installation	22 7/16	570

Note: Convection Speed Oven requires ventilation at the rear of the cavity.

The models shown in this Planning Guide may not be available in all markets and are subject to change at any time. Product specifications may vary from those shown. This Planning Guide should not be used as installation guidance for any product. Further information is required to safely and correctly install the products featured here. Specific installation guidance will be available on our website fisherpaykel.com