



HOSHIZAKI

Instruction Manual

Crescent Cube Icemaker / Dispenser

Models

DKM-500BAJ, BWJ



hoshizakiamerica.com

Issued: 12-12-2016
Revised: 11-5-2024

⚠ WARNING

Only qualified service technicians should install and service the appliance. To obtain the name and phone number of your local Hoshizaki Certified Service Representative, visit www.hoshizakiamerica.com. No installation or service should be undertaken until the technician has thoroughly read this Instruction Manual. Likewise, the owner/manager should not proceed to operate the appliance until the installer has instructed them on its proper operation. Failure to install, operate, and maintain the appliance in accordance with this manual will adversely affect safety, performance, component life, and warranty coverage and may result in costly water damage. Proper installation is the responsibility of the installer. Product failure or property damage due to improper installation is not covered under warranty.

Hoshizaki provides this manual primarily to assist qualified service technicians in the installation, operation, maintenance, and service of the appliance.

Should the reader have any questions or concerns which have not been satisfactorily addressed, please call, send an e-mail message, or write to the Hoshizaki Technical Support Department for assistance.

Phone: 1-800-233-1940; (770) 487-2331

E-mail: techsupport@hoshizaki.com

HOSHIZAKI AMERICA, INC.

618 Highway 74 South

Peachtree City, GA 30269

Attn: Hoshizaki Technical Support Department

NOTE: To expedite assistance, all correspondence/communication **MUST** include the following information:

- Model Number _____
- Serial Number _____
- Complete and detailed explanation of the problem.

IMPORTANT

This manual should be read carefully before the appliance is installed and operated. Read the warnings and guidelines contained in this manual carefully as they provide essential information for the continued safe use and maintenance of the appliance. Retain this manual for any further reference that may be necessary.

CONTENTS

Important Safety Information	4
I. Specifications.....	6
A. Electrical and Refrigerant Data	6
B. Dimensions/Connections	7
1. DKM-500BAJ	7
2. DKM-500BWJ.....	8
II. Installation and Operating Instructions	9
A. Location	9
B. Checks Before Installation.....	10
C. How to Remove Panels	11
D. Setup.....	12
E. Electrical Connection	13
F. Water Supply and Drain Connections	14
1. Icemaker	15
2. Water-Cooled Condenser.....	16
G. Final Checklist	18
1. Pre-Startup	18
2. Post-Startup.....	19
H. Startup	20
III. Maintenance	22
A. Maintenance Schedule.....	22
B. Cleaning and Sanitizing Instructions	23
IV. Preparing the Appliance for Periods of Non-Use	28
V. Disposal	30

Important Safety Information

Throughout this manual, notices appear to bring your attention to situations which could result in death, serious injury, damage to the appliance, or damage to property.

⚠ WARNING Indicates a hazardous situation which could result in death or serious injury.

NOTICE Indicates a situation which could result in damage to the appliance or property.

IMPORTANT Indicates important information about the installation, use, and care of the appliance.

⚠ WARNING

The appliance should be destined only to the use for which it has been expressly conceived. Any other use should be considered improper and therefore dangerous. The manufacturer cannot be held responsible for injury or damage resulting from improper, incorrect, and unreasonable use. Failure to install, operate, and maintain the appliance in accordance with this manual will adversely affect safety, performance, component life, and warranty coverage and may result in costly water damage.

To reduce the risk of death, electric shock, serious injury, or fire, follow basic precautions including the following:

- Only qualified service technicians should install and service the appliance.
- The appliance must be installed in accordance with applicable national, state, and local codes and regulations.
- The appliance requires an independent power supply of proper capacity. See the nameplate for electrical specifications. Failure to use an independent power supply of proper capacity can result in a tripped breaker, blown fuse, damage to existing wiring, or component failure. This could lead to heat generation or fire.
- **THE APPLIANCE MUST BE GROUNDED:** The appliance is equipped with a NEMA 5-20 three-prong grounding plug  to reduce the risk of potential shock hazards. It must be plugged into a properly grounded, independent 3-prong wall outlet. If the outlet is a 2-prong outlet, it is your personal responsibility to have a qualified electrician replace it with a properly grounded, independent 3-prong wall outlet. Do not remove the ground prong from the power cord and do not use an adapter plug. Failure to properly ground the appliance could result in death or serious injury.
- Do not use an extension cord.
- To reduce the risk of electric shock, do not touch the control switch, mode switch, or plug with damp hands. Make sure the control switch is in the "OFF" position before plugging in or unplugging the appliance.
- Do not use an appliance with a damaged power cord. The power cord should not be altered, jerked, bundled, weighed down, pinched, or tangled. Such actions could result in electric shock or fire. To unplug the appliance, be sure to pull the plug, not the cord, and do not jerk the cord.

⚠ WARNING, continued

- Do not make any alterations to the appliance. Alterations could result in electric shock, injury, fire, or damage to the appliance.
- The appliance is not intended for use by persons (including children) with reduced physical, sensory, or mental capabilities, or lack of experience and knowledge, unless they have been given supervision or instruction concerning use of the appliance by a person responsible for their safety.
- Children should be properly supervised around the appliance.
- Do not climb, stand, or hang on the appliance or allow children or animals to do so. Serious injury could occur or the appliance could be damaged.
- Do not use combustible spray or place volatile or flammable substances near the appliance. They might catch fire.
- Keep the area around the appliance clean. Dirt, dust, or insects in the appliance could cause harm to individuals or damage to the appliance.

NOTICE

- Follow the water supply, drain connection, and maintenance instructions carefully to reduce the risk of costly water damage.
- In areas where water damage is a concern, install in a contained area with a floor drain.
- Install the appliance in a location that stays above freezing. Normal operating ambient temperature must be within 45°F to 100°F (7°C to 38°C). If the normal operating ambient temperature is above 90°F (32°C), the compressor insulation cover must be removed.
- Do not leave the appliance on during extended periods of non-use, extended absences, or in sub-freezing temperatures. To properly prepare the appliance for these occasions, follow the instructions in "IV. Preparing the Appliance for Periods of Non-Use."
- Do not place objects on top of the appliance.
- The storage bin is for ice use only. Do not store anything else in the storage bin.

I. Specifications

A. Electrical and Refrigerant Data

The rating label and nameplate provide electrical and refrigerant data. The rating label can be seen by removing the front panel. The nameplate is located on the rear panel. For certification marks, see the nameplate.

We reserve the right to make changes in specifications and design without prior notice.

Model Number	DKM-500BAJ	DKM-500BWJ
AC Supply Voltage	115/60/1	115/60/1
Amperes	13.5 AMPS	12 AMPS
Design Pressure	HI-467PSI LO-170PSI	HI-427PSI LO-230PSI
Refrigerant	404A 1 LB. 12.2 OZ.	404A 1 LB. 2 OZ.

B. Dimensions/Connections

1. DKM-500BAJ

Unit: mm [in.]

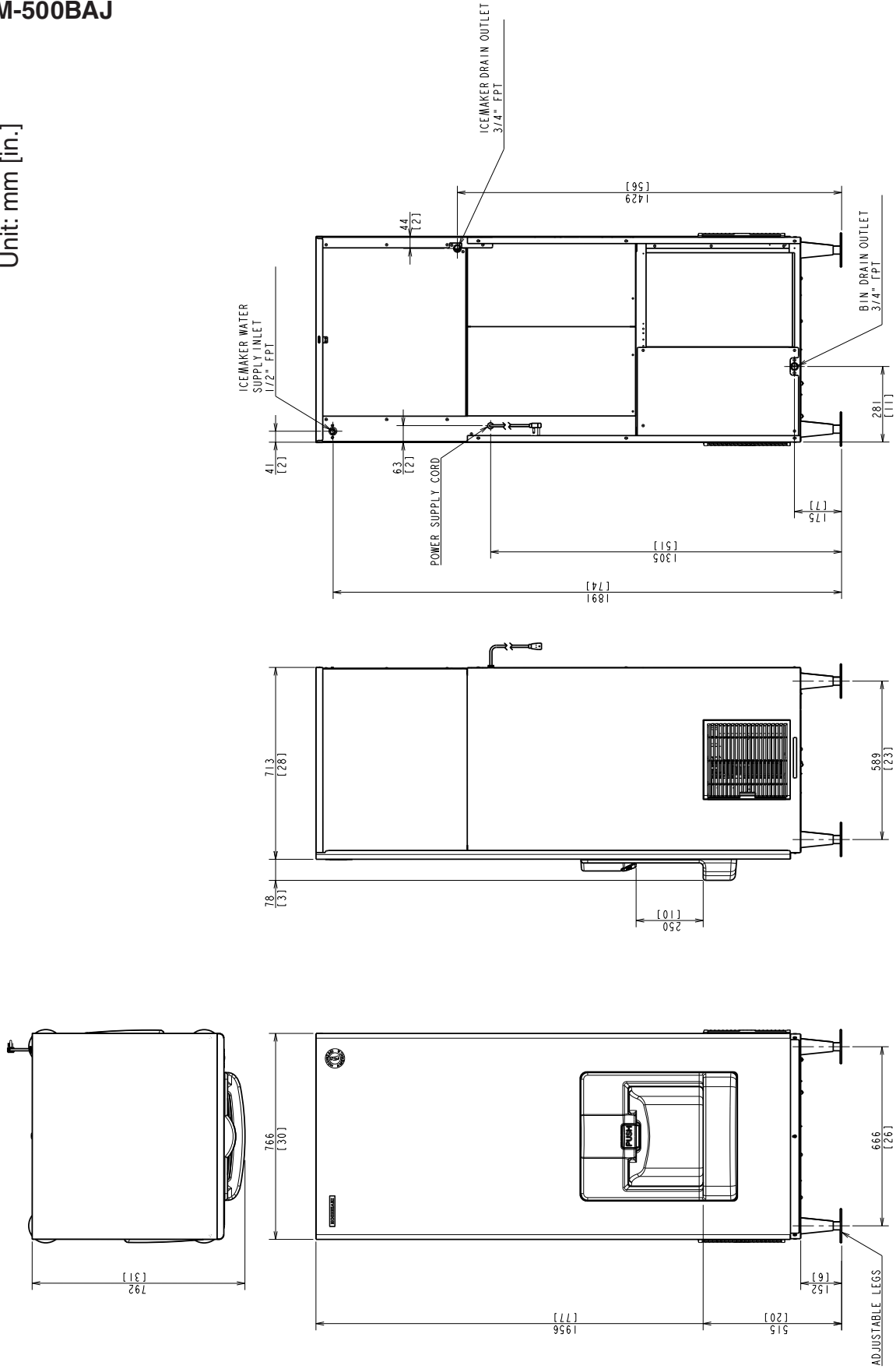

2. DKM-500BWJ

Unit: mm [in.]

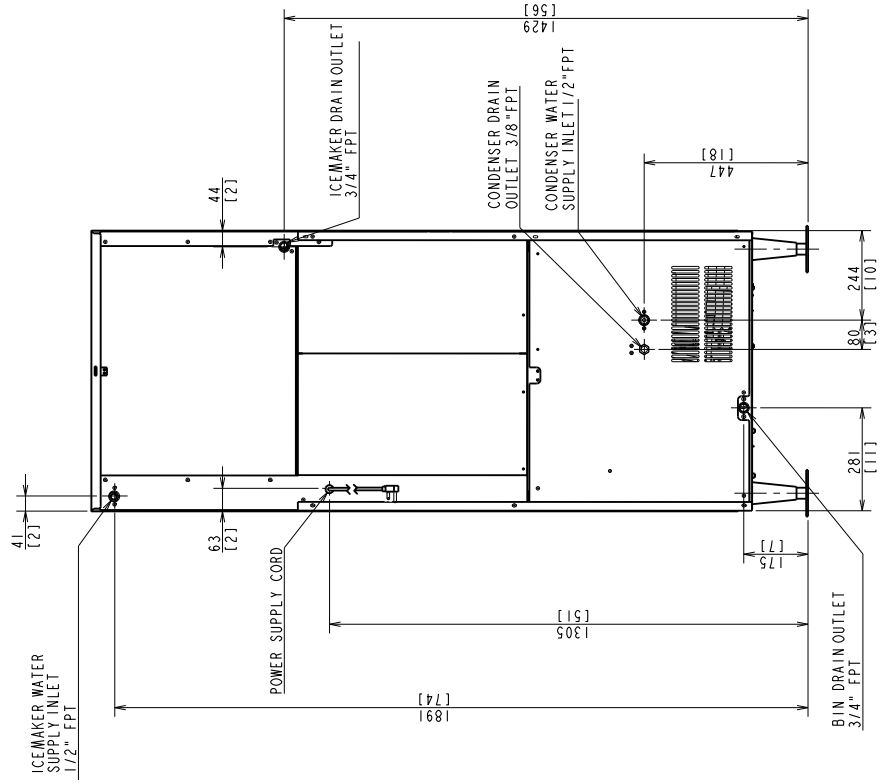
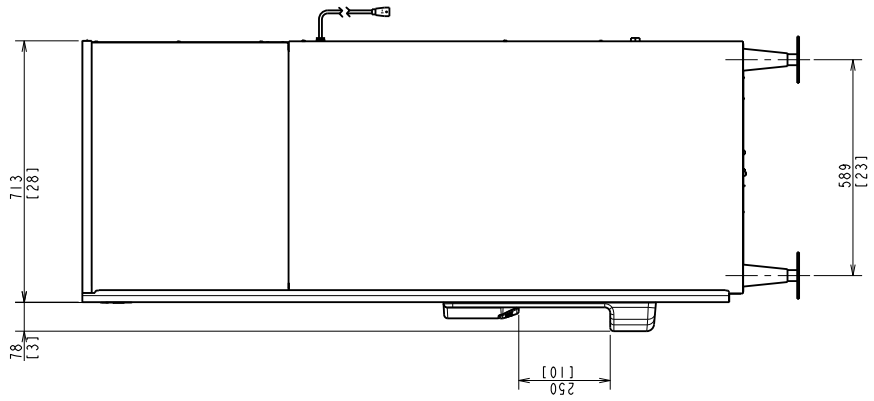
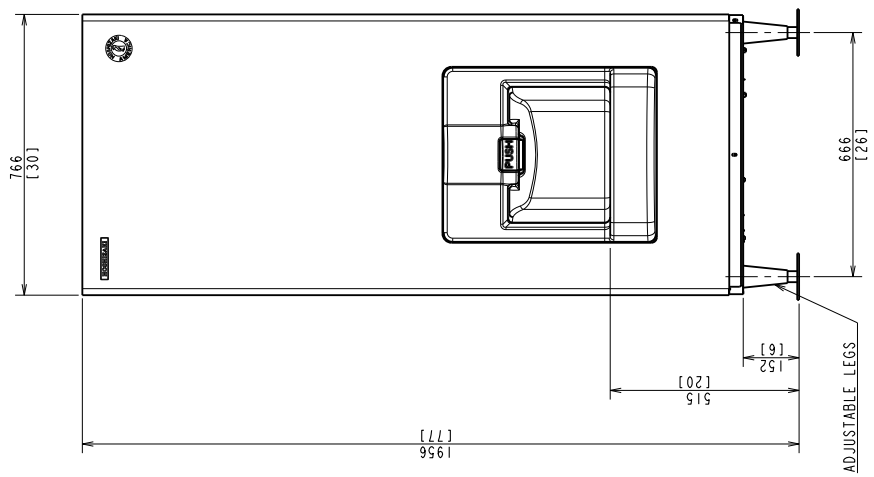
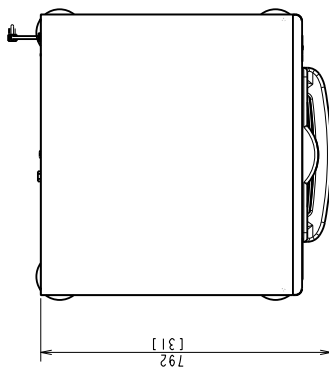

II. Installation and Operating Instructions

⚠ WARNING

- The appliance must be installed in accordance with applicable national, state, and local codes and regulations.
- Failure to install, operate, and maintain the appliance in accordance with this manual will adversely affect safety, performance, component life, and warranty coverage and may result in costly water damage.
- **CHOKING HAZARD:** Ensure all components, fasteners, and thumbscrews are securely in place after installation. Make sure that none have fallen into the storage bin.

A. Location

NOTICE

- The appliance is not intended for outdoor use. Normal operating ambient temperature must be within 45°F to 100°F (7°C to 38°C). If the normal operating ambient temperature is above 90°F (32°C), the compressor insulation cover must be removed. Normal operating water temperature must be within 45°F to 90°F (7°C to 32°C). Operation of the appliance, for extended periods, outside of these normal temperature ranges may affect appliance performance.
 - The appliance will not work at sub-freezing temperatures. To prevent damage to the water supply line, drain the appliance if the air temperature is going to go below 32°F (0°C). See "IV. Preparing the Appliance for Periods of Non-Use."
- The appliance should not be located next to ovens, grills, or other high heat producing equipment.
 - On air-cooled model, allow at least 12" (30 cm) clearance on the left side and 6" (15 cm) clearance at rear, right side, and top for proper air circulation and ease of maintenance and/or service should they be required. On water-cooled model, allow 6" (15 cm) clearance at rear, sides, and top.
 - The location should provide a firm and level foundation for the appliance.

B. Checks Before Installation

- Visually inspect the exterior of the shipping container and immediately report any damage to the carrier. Upon opening the container, any concealed damage should also be immediately reported to the carrier.
- Remove the shipping carton, tape, and packing material. If any are left in the appliance, it will not work properly.
- See the nameplate on the rear panel, and check that your voltage supplied corresponds with the voltage specified on the nameplate.
- Remove the panels to prevent damage when installing the appliance. See "II.C. How to Remove Panels."
- Remove the package containing the accessories.
- Remove the protective plastic film from the panels. If the appliance is exposed to the sun or to heat, remove the film after the appliance cools.
- Check that the refrigerant lines do not rub or touch lines or other surfaces, and that the fan blade (if applicable) turns freely.
- Check that the compressor is snug on all mounting pads.

C. How to Remove Panels

See Fig. 1

- Front Panel: Remove the screw, lift up and slightly towards you. Disconnect the connector from the control box.
- Top Panel: Lift up at front slightly, push rearward, and lift off.
- Side Panels (R1 and L1): Remove the top panel. Remove the screw. Slide forward slightly, and lift off.
- Side Panels (lower): Remove the top panel. Remove the screws and lift off.
- Top and Front Insulation Panels: Remove the top panel. Remove side panel (L1), then lift up and out.

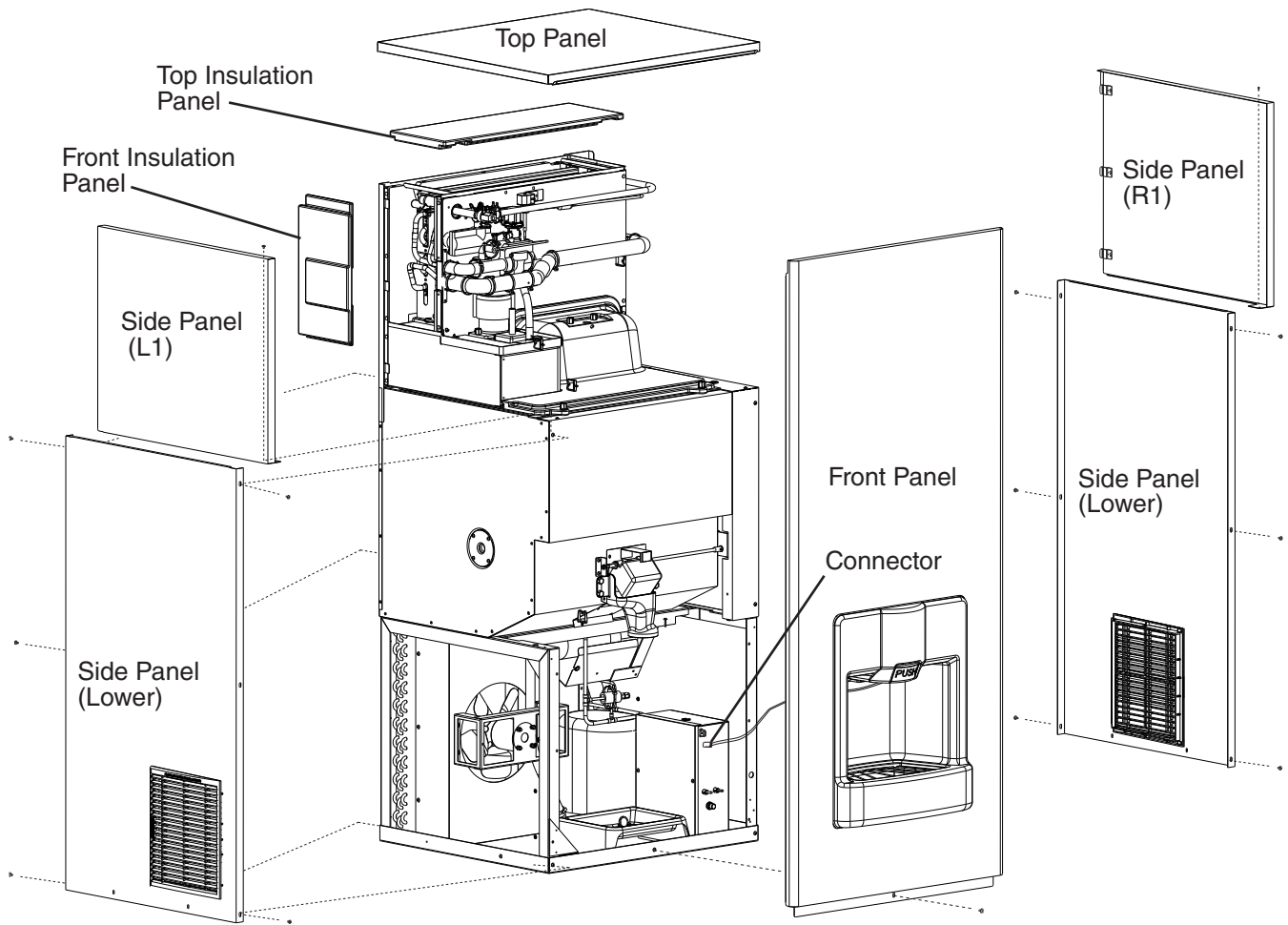

**Model Shown:
DKM-500BAJ**

Fig. 1

D. Setup

- 1) Install the leg protectors to the 4 adjustable legs, then attach the legs to the bottom of the icemaker. See Fig. 2.
- 2) Position the icemaker in the selected permanent location.
- 3) Level the icemaker in both the left-to-right and front-to-rear directions. Adjust the legs to make the icemaker level.
- 4) **NOTICE!** If the normal operating ambient temperature is above 90°F (32°C), remove the compressor insulation cover.

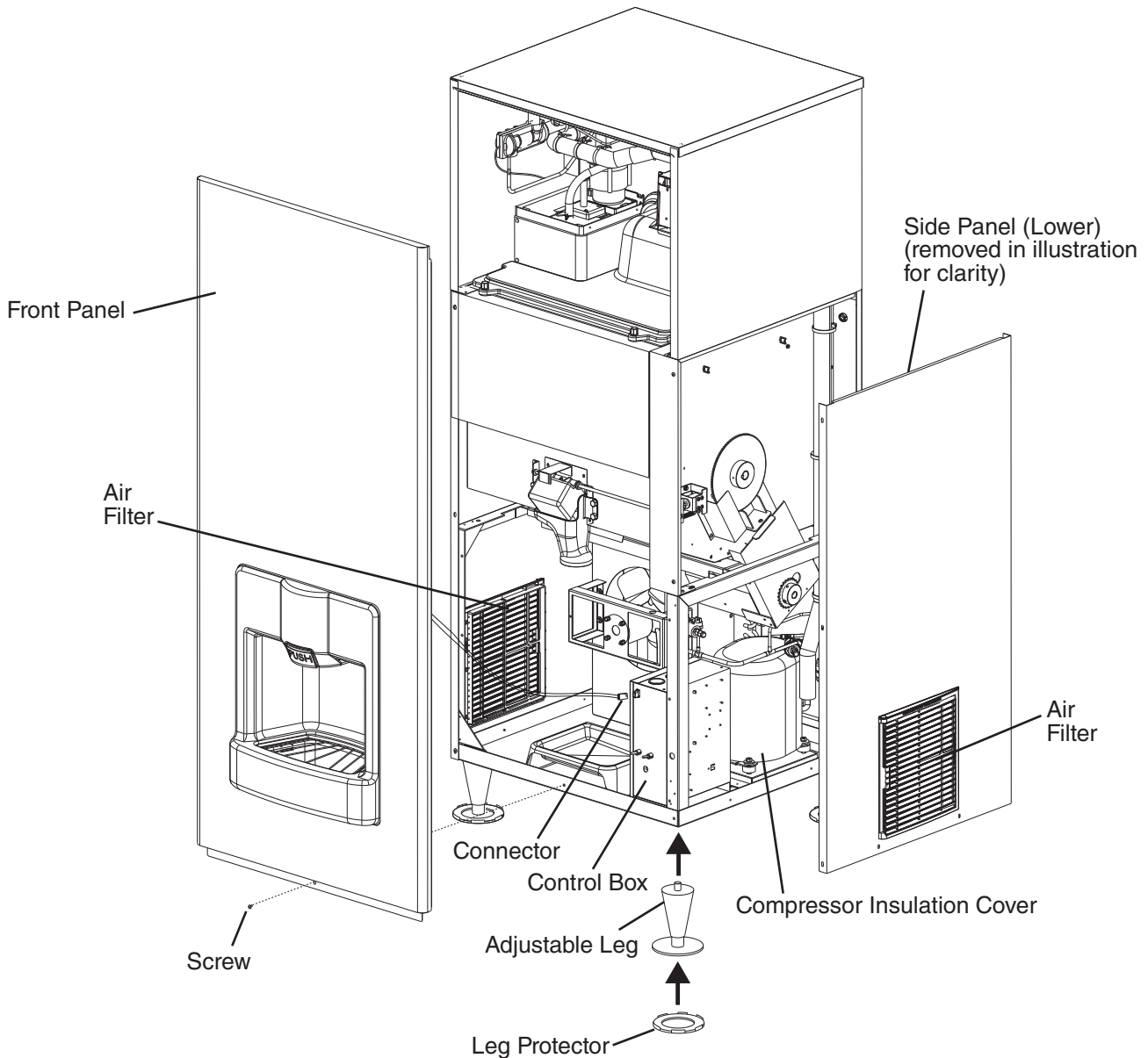

Model Shown:
DKM-500BAJ

Fig. 2

E. Electrical Connection

WARNING

- Electrical connection must meet national, state, and local electrical code requirements. Failure to meet these code requirements could result in death, electric shock, serious injury, fire, or damage.
 - The appliance requires an independent power supply of proper capacity. See the nameplate for electrical specifications. Failure to use an independent power supply of proper capacity can result in a tripped breaker, blown fuse, damage to existing wiring, or component failure. This could lead to heat generation or fire.
 - **THE APPLIANCE MUST BE GROUNDED:** The appliance is equipped with a NEMA 5-20 three-prong grounding plug  to reduce the risk of potential shock hazards. It must be plugged into a properly grounded, independent 3-prong wall outlet. If the outlet is a 2-prong outlet, it is your personal responsibility to have a qualified electrician replace it with a properly grounded, independent 3-prong wall outlet. Do not remove the ground prong from the power cord and do not use an adapter plug. Failure to properly ground the appliance could result in death or serious injury.
 - Do not use an extension cord.
 - To reduce the risk of electric shock, do not touch the control switch, service switch, or plug with damp hands. Make sure the control switch is in the "OFF" position before plugging in or unplugging the appliance.
 - Do not use an appliance with a damaged power cord. The power cord should not be altered, jerked, bundled, weighed down, pinched, or tangled. Such actions could result in electric shock or fire. To unplug the appliance, be sure to pull the plug, not the cord, and do not jerk the cord.
 - The GREEN ground wire in the factory-installed power cord is connected to the appliance. If it becomes necessary to remove or replace the power cord, be sure to connect the power cord's ground wire to this screw upon reattachment.
-
- Usually an electrical permit and services of a licensed electrician are required.
 - The maximum allowable voltage variation is ± 10 percent of the nameplate rating.
 - For optional water dispenser kit installation, refer to the instruction manual included with the kit.

F. Water Supply and Drain Connections

See Figs. 3 through 5

WARNING

Water supply and drain connections must be installed in accordance with applicable national, state, and local regulations.

NOTICE

- Normal operating water temperature must be within 45°F to 90°F (7°C to 32°C). Operation of the appliance, for extended periods, outside of this normal temperature range may affect appliance performance.
- Water supply pressure must be a minimum of 10 PSIG and a maximum of 113 PSIG. If the pressure exceeds 113 PSIG, the use of a pressure reducing valve is required.
- External filters, strainers, or softeners may be required depending on water quality. Contact your local Hoshizaki Certified Service Representative or local Hoshizaki distributor for recommendations.
- In areas where water damage is a concern, install in a contained area with a floor drain.

- A plumbing permit and services of a licensed plumber may be required in some areas.
- The icemaker drain line, storage bin drain line, and water-cooled condenser drain line (if applicable) must be run separately.
- Drain lines must have 1/4" fall per foot (2 cm per 1 m) on horizontal runs to get a good flow. A vented tee connection is also required for proper flow.
- Drain lines should not be piped directly to the sewer system. An air gap of a minimum of 2 vertical inches (5 cm) should be between the end of the drain pipes from the icemaker, storage bin, and water-cooled condenser (if applicable) and the floor drain.

1. Icemaker

Icemaker Water Supply Inlet	Minimum Icemaker Water Supply Line Size	Icemaker Drain Outlet	Minimum Icemaker Drain Line Size
1/2" Female Pipe Thread (FPT)	1/4" Nominal ID Copper Water Tubing or Equivalent	3/4" Female Pipe Thread (FPT)	3/4" Nominal ID Hard Pipe or Equivalent

- An icemaker water supply line shut-off valve and drain valve must be installed.
- Be sure there is sufficient extra water supply line and drain line for the appliance to be pulled out for service.

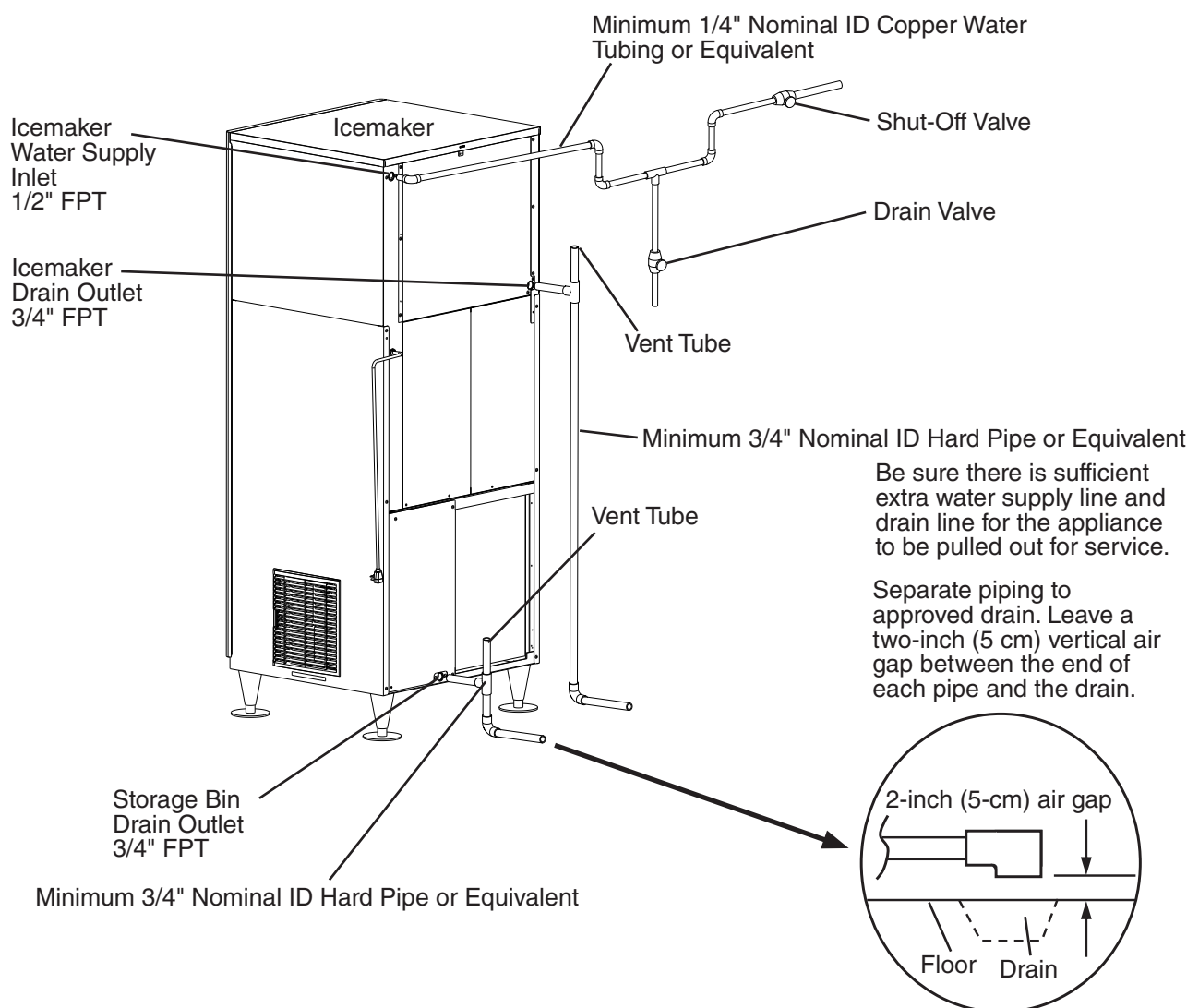

Fig. 3
Air-Cooled Model
 Model Shown:
 DKM-500BAJ

2. Water-Cooled Condenser

a) Connection to an Open Drain System

Condenser Water Supply Inlet	Minimum Condenser Water Supply Line Size	Condenser Drain Outlet	Minimum Condenser Drain Line Size
1/2" Female Pipe Thread (FPT)	1/4" Nominal ID Copper Water Tubing or Equivalent	3/8" Female Pipe Thread (FPT)	1/4" Nominal ID Hard Pipe or Equivalent

- A condenser water supply line shut-off valve and drain valve must be installed.
- In some areas, a back flow preventer may be required in the cooling water circuit.
- In order to maintain the proper high side pressure, the condenser water supply inlet temperature should not drop below 45°F (7°C) and the condenser drain outlet temperature must be in the 104°F to 115°F (40°C to 46°C) range. Once the icemaker installation is complete, confirm the condenser drain outlet temperature 5 minutes after a freeze cycle starts. If the condenser drain outlet temperature is not in the proper range, use a flat blade screwdriver to rotate the adjustment screw on the water-regulating valve until the temperature is in the proper range (rotate counterclockwise to raise temperature or clockwise to lower temperature).

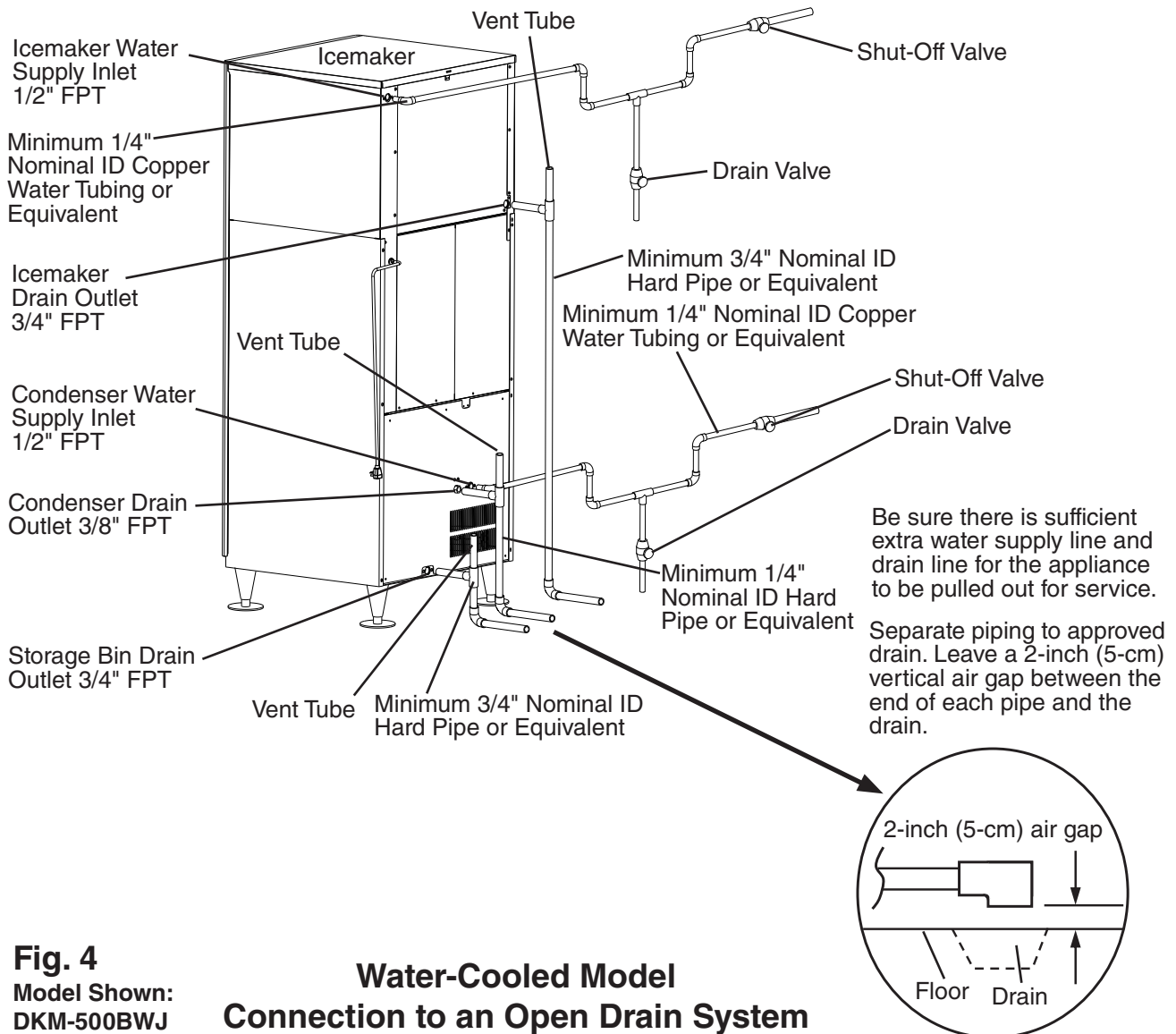

b) Connection to a Closed Loop System

Condenser Water Supply Inlet	Minimum Condenser Water Supply Line Size	Condenser Return Outlet	Minimum Condenser Return Line Size
1/2" Female Pipe Thread (FPT)	1/4" Nominal ID Copper Water Tubing or Equivalent	3/8" Female Pipe Thread (FPT)	1/4" Nominal ID Copper Water Tubing or Equivalent

- Shut-off valves and drain valves must be installed at both the condenser water supply inlet and condenser return outlet.
- Minimum water flow to the condenser is 4 GPM.
- The pressure differential between the condenser water supply inlet and condenser return outlet must be no less than 10 PSIG.
- When using a glycol blend, the solution mixture should be less than 30% glycol.
- In order to maintain the proper high side pressure, the condenser water supply inlet temperature should not drop below 45°F (7°C) and the condenser return outlet temperature must be in the 104°F to 115°F (40°C to 46°C) range. Once the icemaker installation is complete, confirm the condenser return outlet temperature 5 minutes after a freeze cycle starts. If the condenser return outlet temperature is not in the proper range, use a flat blade screwdriver to rotate the adjustment screw on the water-regulating valve until the temperature is in the proper range (rotate counterclockwise to raise temperature or clockwise to lower temperature).

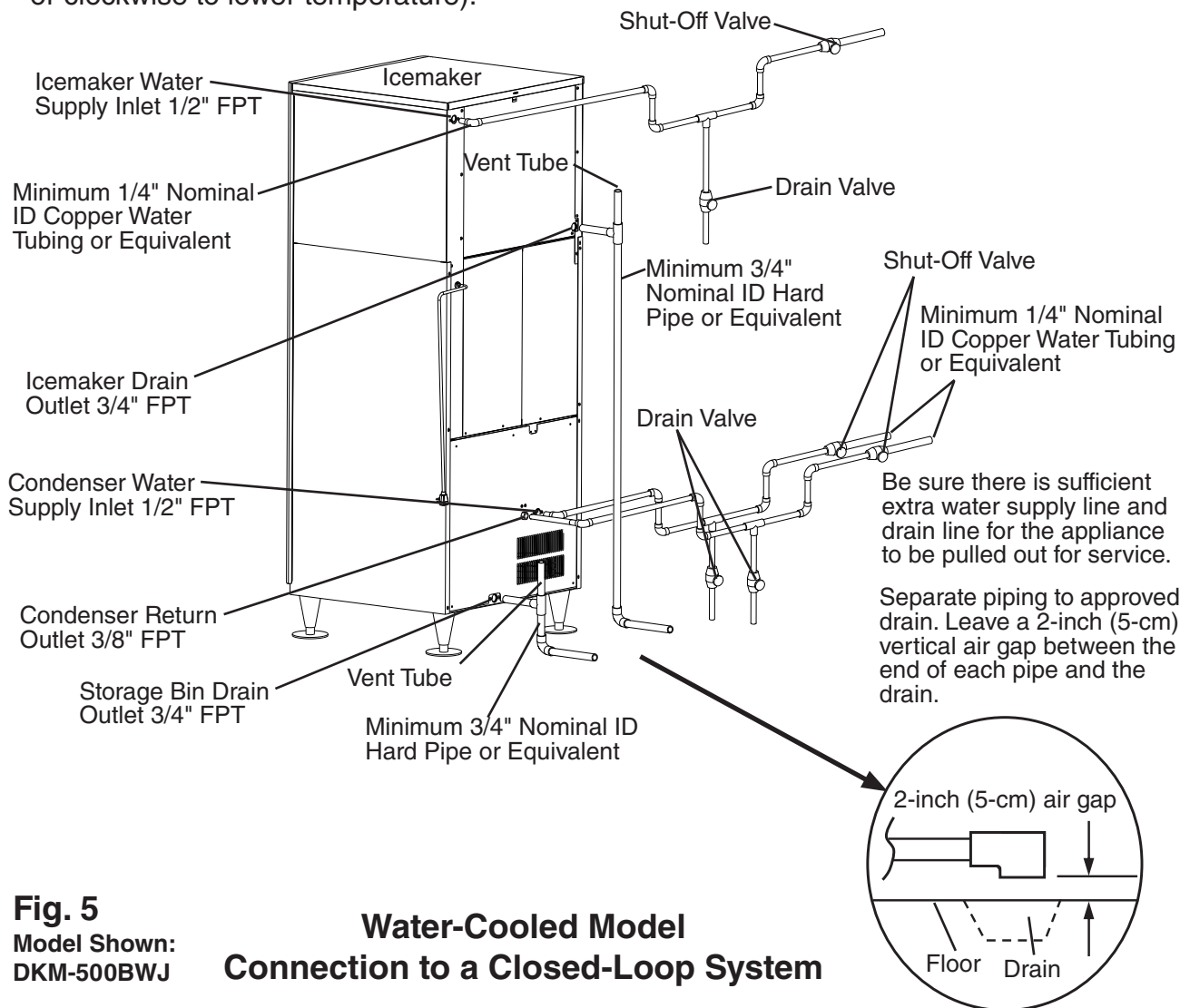

G. Final Checklist

1. Pre-Startup

- 1) Is the icemaker level?
- 2) Is the icemaker in a site where the ambient temperature is within 45°F to 100°F (7°C to 38°C) and the water temperature within 45°F to 90°F (7°C to 32°C) all year around? If the normal operating ambient temperature is above 90°F (32°C), has the compressor insulation cover been removed?
- 3) Air-Cooled Model: Is there at least 12" (30 cm) clearance on the left side and 6" (15 cm) clearance at rear, right side, and top?
Water-Cooled Model: Is there at least 6" (15 cm) clearance at rear, sides, and top?
- 4) Have the shipping carton, tape, and packing material been removed from the icemaker? Is the cube guide in the correct position?
- 5) Have all electrical and water connections been made? Do electrical and water connections meet applicable national, state, and local code and regulation requirements?
- 6) Has the power supply voltage been checked or tested against the nameplate rating? Is the power supply a properly grounded, independent 3-prong wall outlet?
- 7) Are the water supply and drain lines sized as specified? Are the water supply line shut-off valve(s) and drain valve(s) installed? Has the water supply pressure been checked to ensure a minimum of 10 PSIG and a maximum of 113 PSIG?
- 8) Is the compressor snug on all mounting pads? Have the refrigerant lines been checked to make sure they do not rub or touch other lines or surfaces? Has the fan blade (if applicable) been checked to make sure it turns freely?
- 9) Are all components, fasteners, and thumbscrews securely in place?
- 10) Continue to "H. Startup."

2. Post-Startup

⚠ WARNING

<p>CHOKING HAZARD: Ensure all components, fasteners, and thumbscrews are securely in place after installation. Make sure that none have fallen into the dispenser unit/ice storage bin.</p>
--

- 1) Has the bin control operation been confirmed?
- 2) Are all components, fasteners, and thumbscrews securely in place?
- 3) Has the end user been given the instruction manual, and instructed on how to operate the appliance and the importance of the recommended periodic maintenance?
- 4) Has the end user been given the contact information of an authorized service agent?
- 5) Has the warranty registration been completed and submitted to the factory?

H. Startup

⚠ WARNING

All parts are factory-adjusted. Improper adjustments may adversely affect safety, performance, component life, and warranty coverage.

NOTICE

- If the icemaker is turned off, wait for at least 3 minutes before restarting the icemaker to prevent damage to the compressor.
- To prevent damage to the water pump seal, do not leave the control switch in the "PUMP" position when the water tank is empty.
- At startup, confirm that all internal and external connections are free of leaks.

- 1) Open the water supply line shut-off valve(s).
- 2) Remove the front panel and disconnect the connector from the control box (if the front panel is not already removed).
- 3) Make sure the control switch on the control box is in the "OFF" position, then plug the icemaker into the electrical outlet.
- 4) Move the mode switch on the control box to the "ICE" position, then move the control switch to the "ON" position. Replace the front panel in its correct position.
- 5) Allow the icemaker to operate for 10 minutes.
- 6) After 10 minutes of operation, confirm bin control operation. Remove the front panel, then press and hold the bin control's actuator paddle. The compressor and fan motor should de-energize within 15 seconds.
- 7) Remove the front panel, then move the control switch to the "OFF" position.
- 8) Remove the front insulation panel. Next, remove the drain plug located in the bottom of the water tank. Allow the water tank to drain. See Fig. 6.
- 9) After the water tank has drained, replace the drain plug in its correct position. Be careful not to cross thread the drain plug.
- 10) Disconnect the bin control connector. See Fig. 7. Remove the 3 thumbscrews securing the bin cover, then remove the bin cover with the bin control attached.

Fig. 6

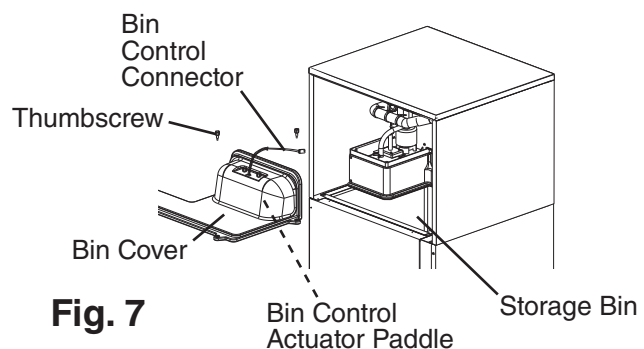
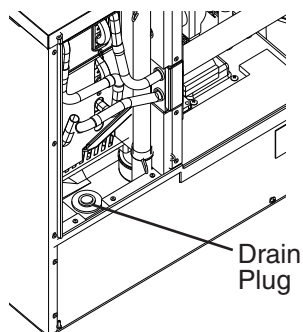

- 13) Clean the storage bin liner using a neutral cleaner. Rinse thoroughly after cleaning.
- 14) Reconnect the bin control connector.
- 15) Plug the icemaker back in to start the automatic icemaking process.
- 16) To confirm bin control operation, press and hold the bin control's actuator paddle during the first 5 minutes of the freeze cycle. The icemaker should shut down in approximately 5 seconds.
- 17) Replace the bin cover in its correct position.
- 18) Reconnect the connector from the front panel to the control box and replace the front panel in its correct position.
- 19) On water-cooled model, confirm proper condenser drain outlet/return outlet temperature as outlined in "II.F.2. Water-Cooled Condenser."

III. Maintenance

The appliance must be maintained in accordance with the instruction manual and labels provided. Consult with your local Hoshizaki Certified Service Representative about maintenance service.

⚠ WARNING

- Only qualified service technicians should service the appliance.
- To reduce the risk of electric shock, do not touch the control switch or service switch with damp hands.
- Move the control switch to the "OFF" position and unplug the unit from the electrical outlet before servicing.
- **CHOKING HAZARD:** Ensure all components, fasteners, and thumbscrews are securely in place after any maintenance is done to the appliance. Make sure that none have fallen into the storage bin.

A. Maintenance Schedule

The maintenance schedule below is a guideline. More frequent maintenance may be required depending on water quality, the appliance's environment, and local sanitation regulations.

Maintenance Schedule		
Frequency	Area	Task
Bi-Weekly	Air Filters	Inspect. Wash with warm water and neutral cleaner if dirty.
Monthly	External Water Filters	Check for proper pressure and change if necessary.
	Appliance Exterior	Wipe down with a clean, soft cloth. Use a damp cloth containing a neutral cleaner to wipe off oil or dirt build up. Clean any chlorine staining (rust colored spots) using a non-abrasive cleanser.
Yearly	Icemaker and Dispenser Unit/ Storage Bin	Clean and sanitize per the cleaning and sanitizing instructions provided in this manual. See "III.B. Cleaning and Sanitizing Instructions."
	Water Supply Inlet	Close the icemaker water supply line shut-off valve and drain the water system. Clean the water supply inlet screen.
	Condenser	Inspect. Clean if necessary by using a brush or vacuum cleaner. More frequent cleaning may be required depending on location.
	Water Hoses	Inspect the water hoses and clean/replace if necessary.

B. Cleaning and Sanitizing Instructions

The appliance must be cleaned and sanitized at least once a year. More frequent cleaning and sanitizing may be required in some water conditions.

⚠ WARNING

- To prevent injury to individuals and damage to the icemaker, do not use ammonia type cleaners.
- Carefully follow any instructions provided with the bottles of cleaning and sanitizing solution.
- Always wear liquid-proof gloves and goggles to prevent the cleaning and sanitizing solutions from coming into contact with skin or eyes.
- Do not leave the icemaker unattended when panels are off.

NOTICE

- To prevent damage to the water pump, do not leave the control switch in the "PUMP" position for extended periods when the water tank is empty.
- Terminating a cleaning/sanitizing cycle early:
 - a) Terminating a cleaning cycle at step 4 or earlier in "Cleaning" below, returns the icemaker to the normal icemaking mode. The control board "CLEAN" LED turns off.
 - b) Terminating a cleaning cycle at step 5 or later in "Cleaning" below, sends the icemaker into a 3-rinse cycle (app. 18 min.). The control board "CLEAN" LED remains on throughout the 3-rinse cycles. After the 3rd rinse cycle, icemaker goes into the normal icemaking mode and the control board "CLEAN" LED turns off.

1. Preparation

- 1) Remove all ice from the evaporator.

Note: To remove cubes on the evaporator, remove the front panel and disconnect the connector from the control box. See Fig. 8. Move the control switch on the control box to the "OFF" position and move it back to the "ON" position after 3 minutes. The harvest cycle starts and the cubes will be removed from the evaporator.

- 2) Reconnect the connector from the front panel to the control box and replace the front panel in its correct position. Dispense all of the ice from the storage bin.

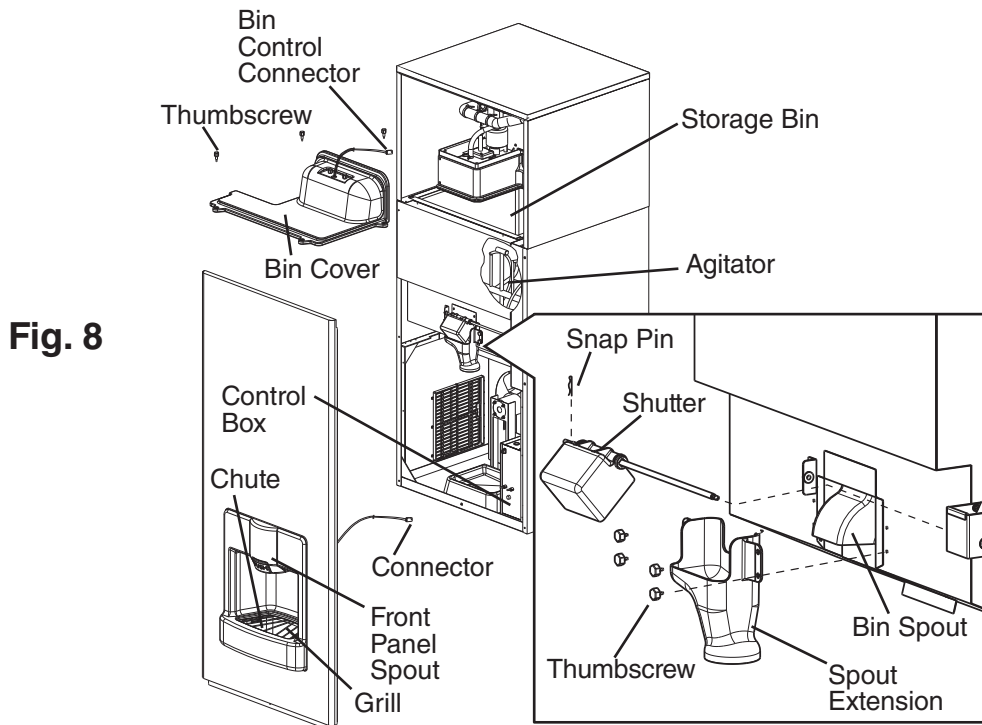

- 3) Remove the front panel and disconnect the connector from the control box.
- 4) Remove the front insulation panel. Next, remove the drain plug located in the bottom of the water tank. Allow the water tank to drain. See Fig. 9.
- 5) After the water tank has drained, replace the drain plug in its correct position. Be careful not to cross thread the drain plug.

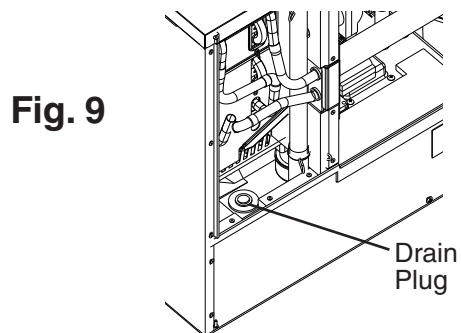

- 6) Move the control switch to the "OFF" position. Unplug the icemaker from the electrical outlet.
- 7) Disconnect the bin control connector. Remove the 3 thumbscrews securing the bin cover, and remove the bin cover with the bin control attached.
- 8) In bad or severe water conditions, clean the float switch assembly as described below.
 - a. Remove the 3 screws securing the float switch assembly, then remove the assembly.
 - b. Remove the retainer rod from the bottom of the float switch housing, then remove the float. Be careful not to bend the retainer rod excessively when removing it.
 - c. Wipe down the float switch housing, shaft, float, and retainer rod with cleaning solution. Clean the inside of the rubber boot and hose with cleaning solution. Rinse the parts thoroughly with clean water.
 - d. Reassemble the float switch assembly and replace it in its correct position. Secure the float switch assembly with the screws.

2. Cleaning

- 9) Move the mode switch to the "CLEAN" position, then move the control switch to the "ON" position (1 short beep occurs, then 3 seconds later 1 long beep occurs). Replace the front panel. The water tank drains and then fills.
- 10) When the control board starts beeping (2 beep sequence), remove the front panel. Move the control switch to the "OFF" position.
- 11) Remove the front insulation panel, then pour 10.5 fl. oz. (311 ml) of Hoshizaki "Scale Away" into the water tank.
- 12) Move the control switch to the "ON" position (1 short beep occurs, then 3 seconds later 1 long beep occurs). Replace the front panel. To avoid excessive foaming in the water tank, there is a 1 minute delay before circulation begins. After approximately 30 minutes of circulation, the icemaker performs 3 rinse cycles.
- 13) When the control board starts beeping (5 beep sequence), remove the front panel. Move the control switch to the "OFF" position.
- 14) In bad or severe water conditions, turn off the power supply, then remove, clean (cleaning solution = 5 oz. Hoshizaki "Scale Away" per gallon of warm water), rinse, and replace the cube guide, float switch, water supply tubes, spray tubes, and spray guides; turn on the power supply when complete. Otherwise, continue to step 16.

3. Sanitizing

- 16) Confirm the mode switch is in the "CLEAN" position, then move the control switch to the "ON" position (1 short beep occurs, then 3 seconds later 1 long beep occurs).
Replace the front panel. The water tank drains and then fills.
- 17) When the control board starts beeping (2 beep sequence), remove the front panel.
Move the control switch to the "OFF" position.
- 18) Remove the front insulation panel, then pour 1.0 fl. oz. (30 ml) of a 7.5% sodium hypochlorite solution (chlorine bleach) into the water tank. Replace the front insulation panel. **IMPORTANT! Use regular bleach with no additives. Using a bleach with additives causes excessive foaming during sanitizing, reducing the effectiveness of sanitizing.**
- 19) Move the control switch to the "ON" position (1 short beep occurs, then 3 seconds later 1 long beep occurs). Replace the front panel. To avoid excessive foaming in the water tank, there is a 1 minute delay before circulation begins. After approximately 30 minutes of circulation, the icemaker performs 3 rinse cycles.
- 20) When the control board starts beeping (5 beep sequence), remove the front panel.
Move the control switch to the "OFF" position.
- 21) Clean the dispenser unit/ice storage bin liner using a neutral cleaner. Rinse thoroughly after cleaning.
- 22) Move the mode switch to the "ICE" position, then move the control switch to the "ON" position.
- 23) Replace all panels in their correct positions.

4. Cleaning Procedure - Storage Bin

- 24) Dilute 5 fl. oz. (148 ml) of Hoshizaki "Scale Away" with 1 gal. (3.8 l) of warm water.
- 25) Make sure the control switch is in the "OFF" position and the icemaker is unplugged.
- 26) Remove the grill and chute from the front panel.
- 27) Remove the shutter and spout extension as follows:
 - a. Remove the snap pin fitted to the shutter shaft. Shift the shaft to the left, pull out the right side and slide out.
 - b. Remove the 4 thumbscrews securing the spout extension and remove the spout extension.
- 28) Remove the 2 thumbscrews securing the bin control assembly to the bin cover. Note the orientation of the stainless steel bracket, then remove the bin control and bracket from the bin cover.
- 29) Scrub the inside of the storage bin, the agitator, the bin spout, the spout extension, the shutter, the front panel spout, the grill, the chute, the bin cover, and the bin control assembly using a nylon scouring pad, brushes, and cleaning solution.
- 30) Rinse all parts thoroughly with clean water, then proceed to "4. Sanitizing Procedure – Storage Bin".

5. Sanitizing Procedure - Storage Bin

- 31) Dilute .5 fl. oz. (15 ml or 1 tbs) of a 7.5% sodium hypochlorite solution (chlorine bleach) with 1 gal. (3.8 l) of warm water.
- 32) Wash all parts from step 6 of "3. Cleaning Procedure – Storage Bin" with the sanitizing solution.
- 33) Rinse all parts thoroughly with clean water.
- 34) Reassemble all parts in the reverse order of the removal procedure.
- 35) Plug the icemaker back in. Move the control switch to the "ON" position to start the automatic icemaking process.
- 36) Reconnect the connector from the front panel to the control box and replace the front panel in its correct position.

IV. Preparing the Appliance for Periods of Non-Use

NOTICE

- When storing the appliance for an extended time or in sub-freezing temperatures, follow the instructions below to prevent damage.
- To prevent damage to the water pump, do not leave the control switch in the "PUMP" position for extended periods when the water tank is empty.

When the icemaker is not used for two or three days under normal conditions, it is sufficient to move the control switch to the "OFF" position. When storing the icemaker for an extended time or in sub-freezing temperatures, follow the instructions below.

1. Remove the ice from the storage bin:

- 1) Close the icemaker water supply line shut-off valve, then open the icemaker water supply line drain valve.
- 2) Remove the front panel and move the control switch on the control box to the "OFF" position.
- 3) Replace the front panel in its correct position and dispense all of the ice from the storage bin.

2. Remove the water from the water tank:

- 4) Remove the front panel and disconnect the connector from the control box.
- 5) Remove the front insulation panel. Next, remove the drain plug located in the bottom of the water tank. Allow the water tank to drain. See Fig. 10.
- 6) After the water tank has drained, replace the drain plug in its correct position. Be careful not to cross thread the drain plug.

Fig. 10

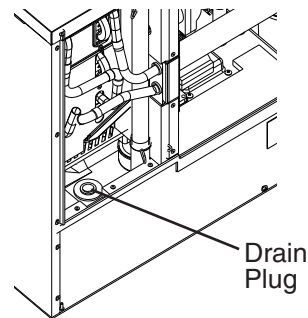

3. Remove the water from the icemaker water supply line:

- 7) Unplug the icemaker from the electrical outlet.
- 8) Allow the water supply line to drain by gravity.
- 9) Attach a compressed air or carbon dioxide supply to the icemaker water supply line drain valve.
- 10) Confirm the mode switch is in the "ICE" position, then move the control switch to the "ON" position.
- 11) Replace the front panel and reconnect the connector to the control box.
- 12) Blow the icemaker water supply line out using the compressed air or carbon dioxide supply.
- 13) Remove the front panel and move the control switch to the "OFF" position.
- 14) Close the icemaker water supply line drain valve.

- 15) Disconnect the bin control connector. Remove the 3 thumbscrews securing the bin cover, and remove the bin cover with the bin control attached.
- 16) Clean the storage bin using a neutral cleaner. Rinse thoroughly after cleaning.
- 17) Replace the bin cover in its correct position and reconnect the bin control connector.
- 18) For water-cooled model, proceed to the next section. For air-cooled model, the procedure is complete. Reconnect the connector from the front panel to the control box and replace the front panel in its correct position.

3. On water-cooled model, remove the water from the water-cooled condenser:

- 19) Make sure the control switch is in the "OFF" position and the icemaker is unplugged.
- 20) Remove the left side panel.
- 21) Close the condenser water supply line shut-off valve. If connected to a closed loop system, also close the condenser return line shut-off valve.
- 22) Open the condenser water supply line drain valve. If connected to a closed loop system, also open the condenser return line drain valve.
- 23) Attach a compressed air or carbon dioxide supply to the condenser water supply line drain valve.
- 24) Open the water regulating valve by using a screwdriver to pry up on the spring retainer underneath the spring. While holding the valve open, blow out the condenser using the compressed air or carbon dioxide supply until water stops coming out.
- 25) Close the drain valve(s) and replace the left side panel in its correct position.
- 26) Reconnect the connector from the front panel to the control box and replace the front panel in its correct position.

4. Restart Instructions

- 1) Open icemaker water supply line shut-off valve.
- 2) Follow the steps in "III.B. Cleaning and Sanitizing Instructions" prior to restarting the icemaker.

V. Disposal

The appliance contains refrigerant and must be disposed of in accordance with applicable national, state, and local codes and regulations. Refrigerant must be recovered by properly certified service personnel.

HOSHIZAKI AMERICA, INC.

618 Hwy. 74 South, Peachtree City, GA 30269 USA (P) 770.487.2331 (F) 770.487.3360 hoshizakiamerica.com 1A7880-010