

Fort Worth, Texas 76140

ASSEMBLY INSTRUCTIONS

2545

FULL PLATFORM BED

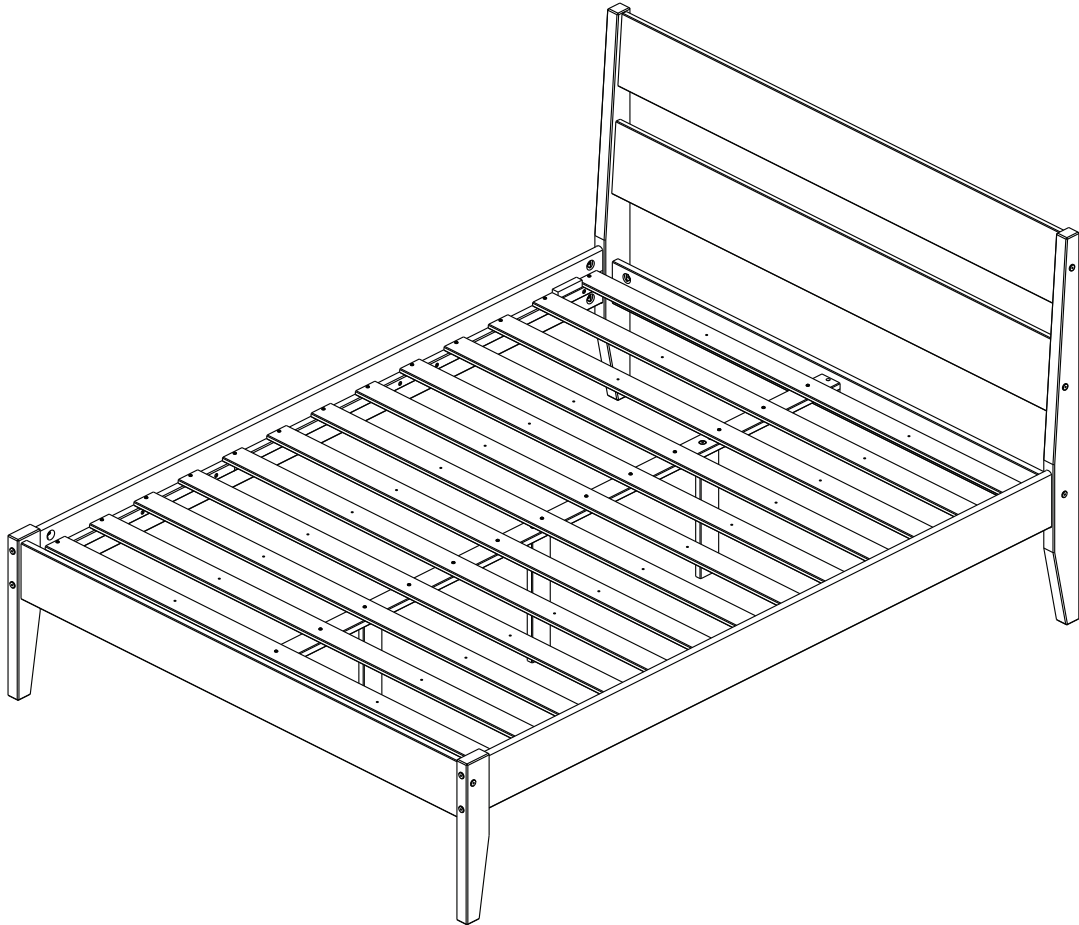

Thank you for purchasing this quality product. Be sure to check all packing material carefully for small parts which may have come loose inside the carton during shipment. Separate, identify and count all parts and hardware. Compare with the parts list to make sure that all parts are included.

**”DO NOT TIGHTEN SCREWS UNTIL COMPLETELY ASSEMBLED”**

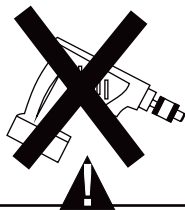

Tools Required

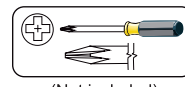

(Not included)



(Not included)

**\*Use of power tool to assemble this product will invalidate any claim and damage this product making unsafe !**  
**\*Please assemble on a clean soft surface to avoid damage.**

**IMPORTANT:**

**PLEASE READ INSTRUCTION BEFORE STARTING THE ASSEMBLY**



**Identifying the Hardware/part list-** Identify the hardware using the illustrations below.

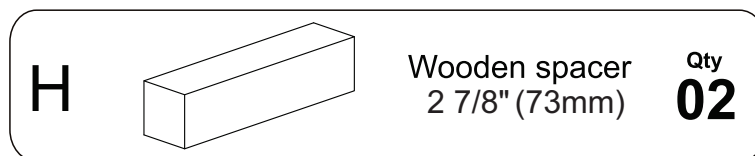
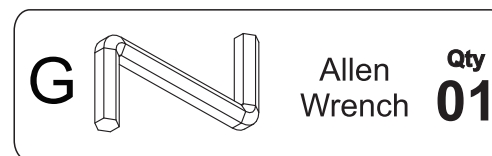
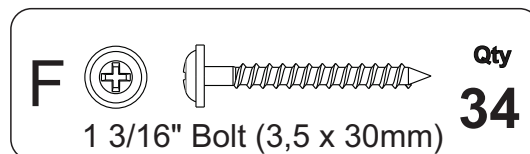
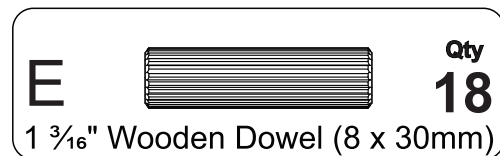
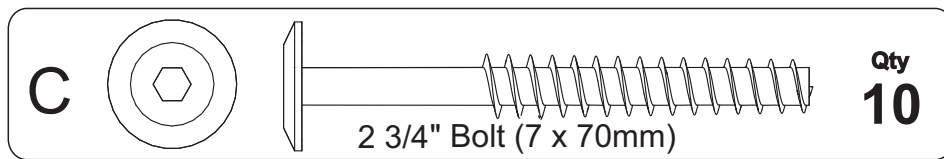
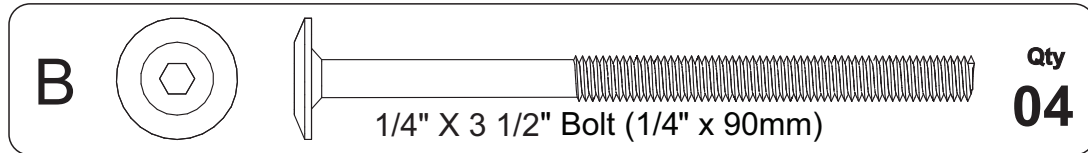
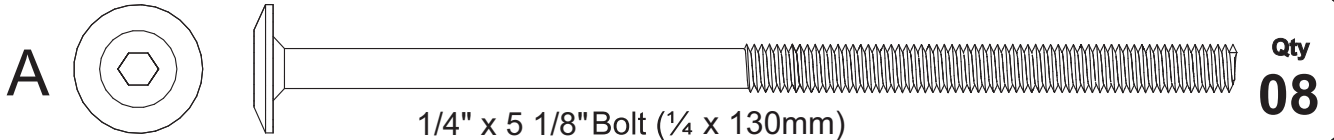

\*Actual size of screws and bolts, for measurements checking.

# 01



PLEASE ASSEMBLE  
ON THE GROUND.

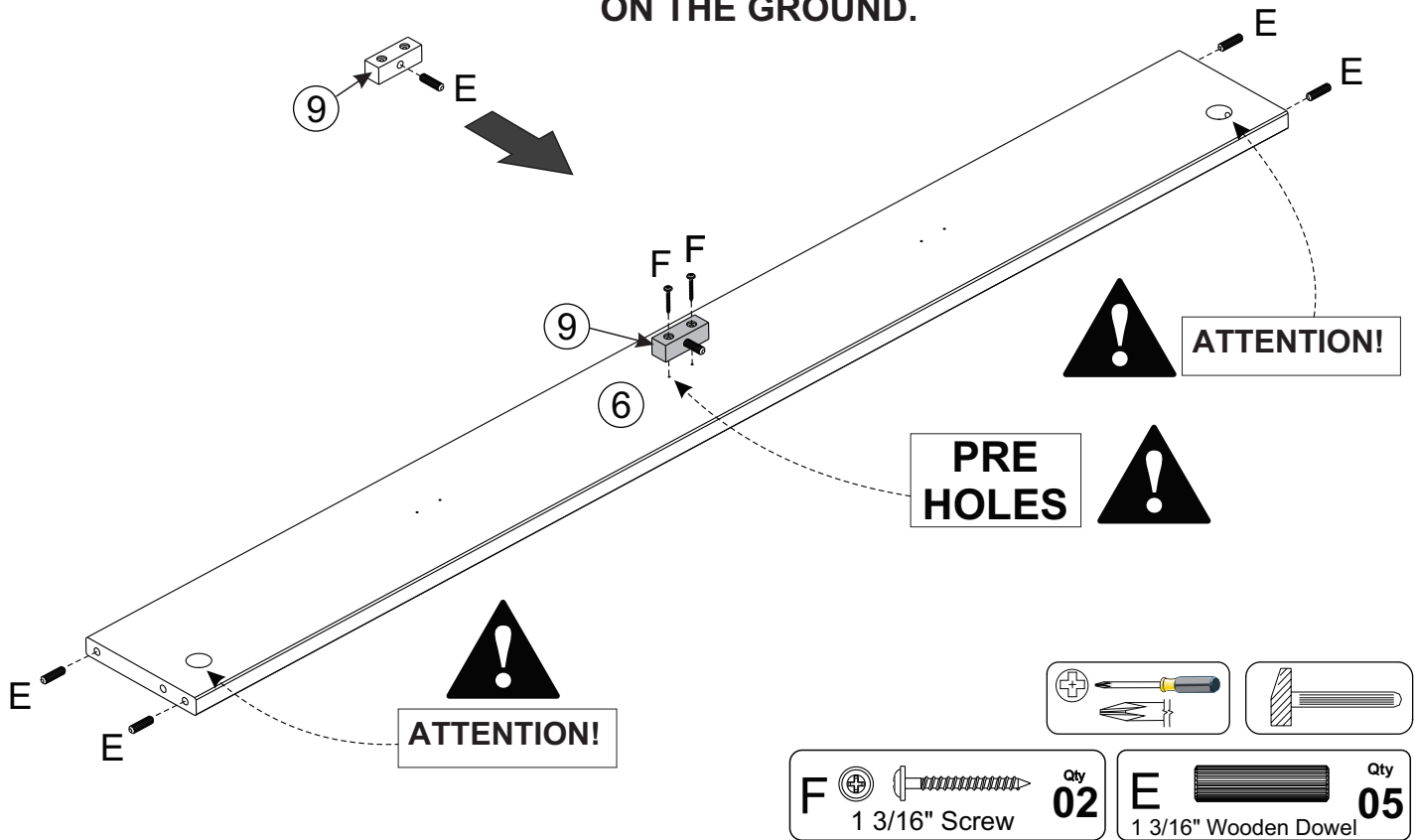

# 02



ATTENTION!  
FACING UP



INSIDE  
HOLES

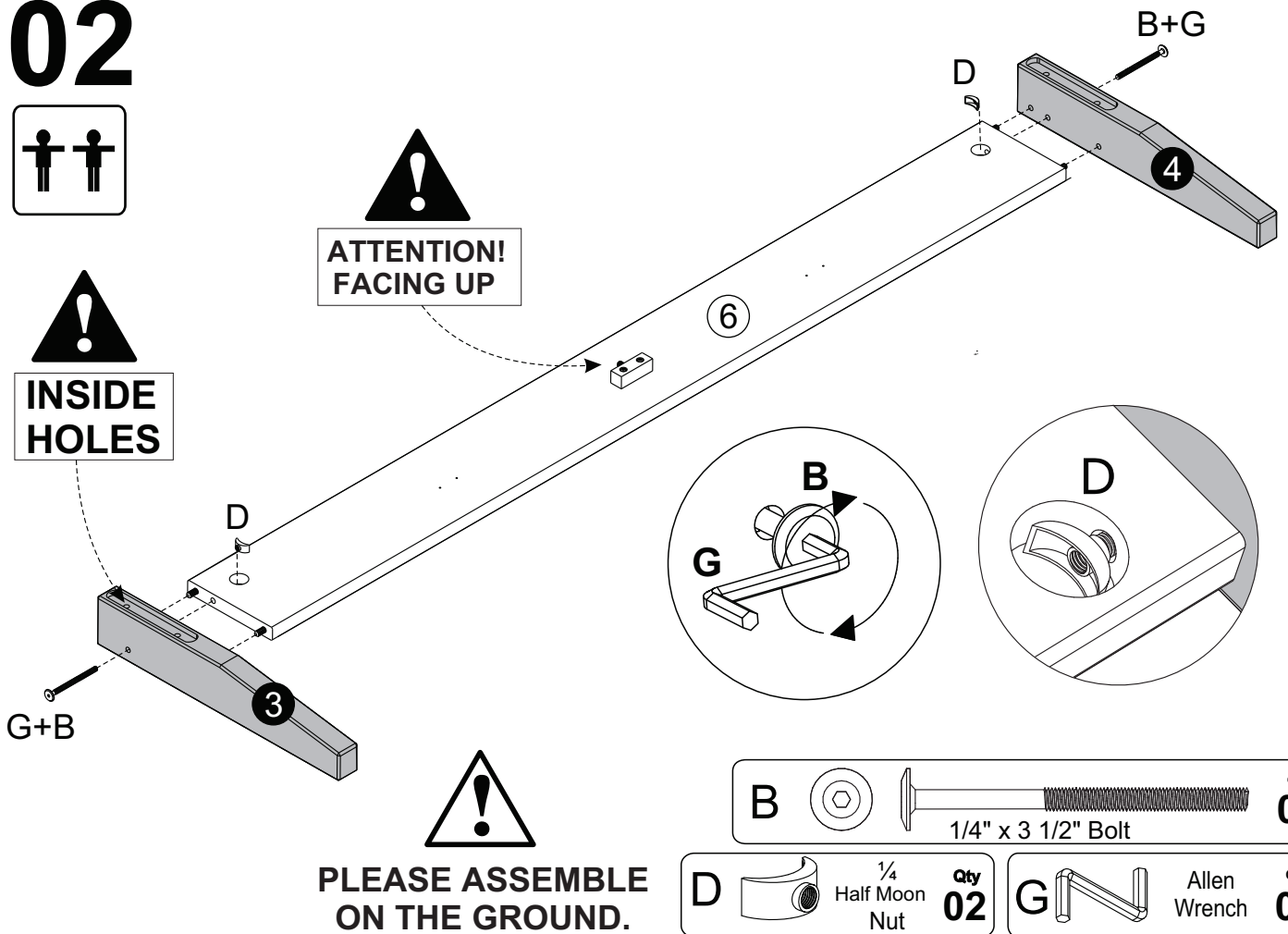

# 03



PLEASE ASSEMBLE  
ON THE GROUND.

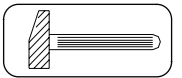
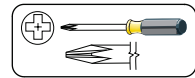
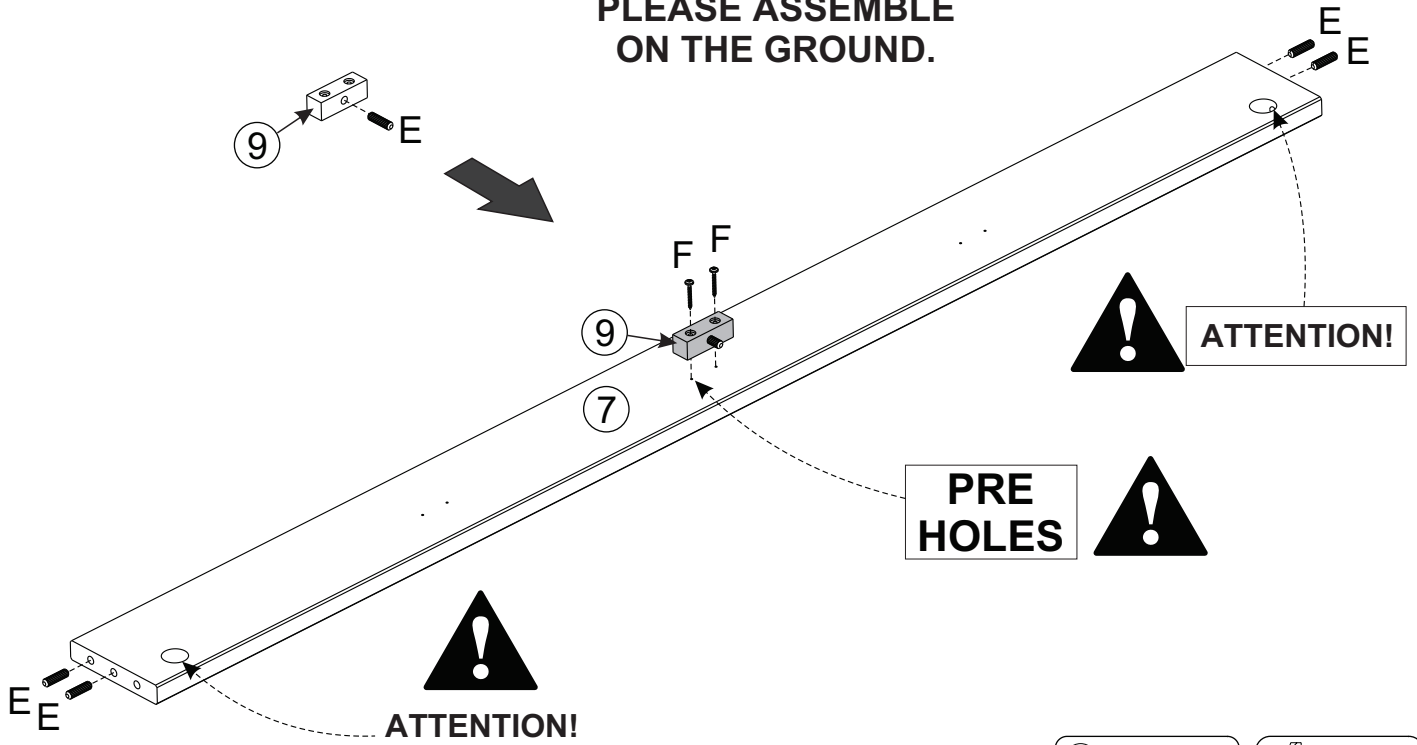

**F**  Qty **02**  
1 3/16" Screw

**E**  Qty **05**  
1 3/16" Wooden Dowel

# 04

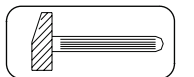
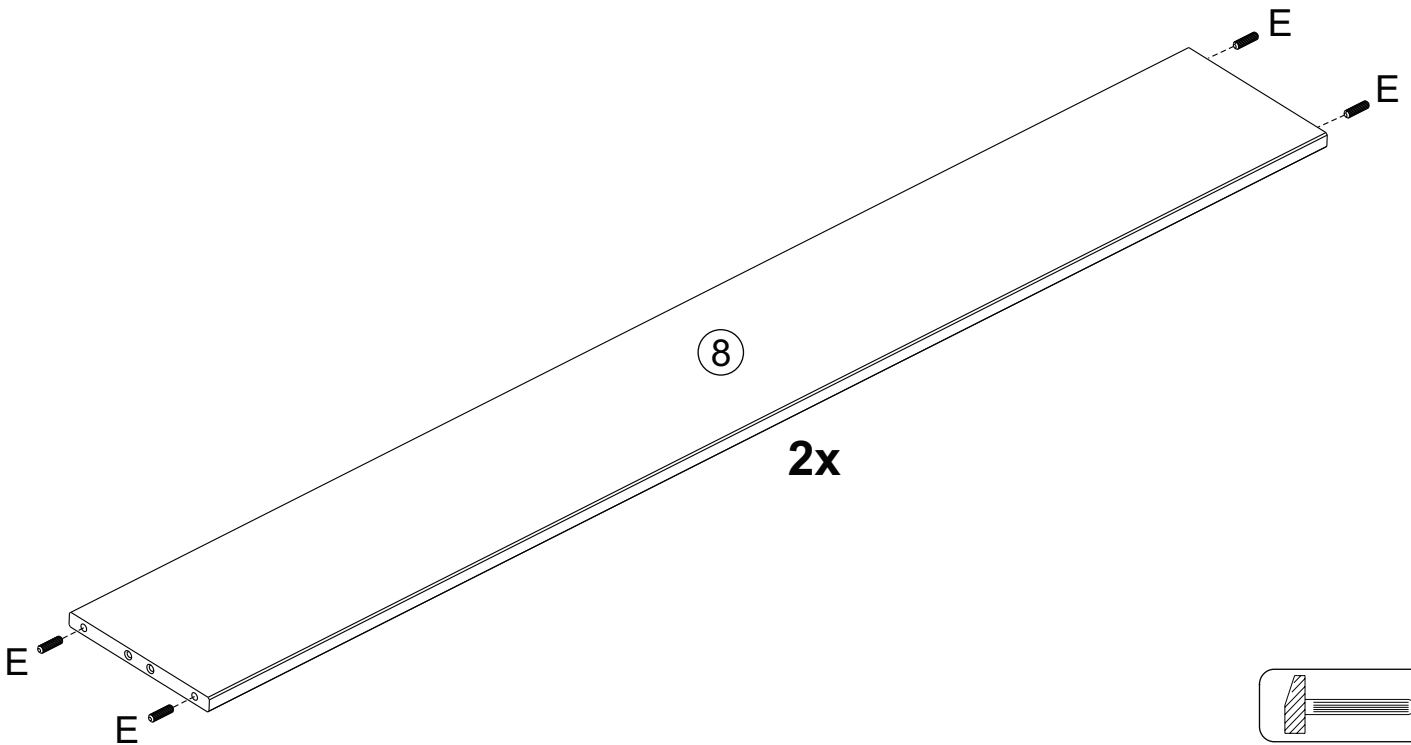

**E**  Qty **08**  
1 3/16" Wooden Dowel

# 05

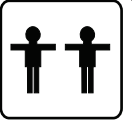

PLEASE ASSEMBLE  
ON THE GROUND.

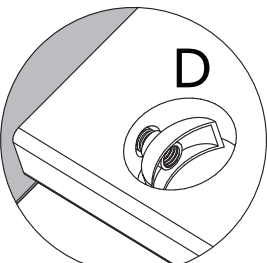
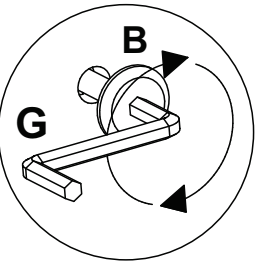
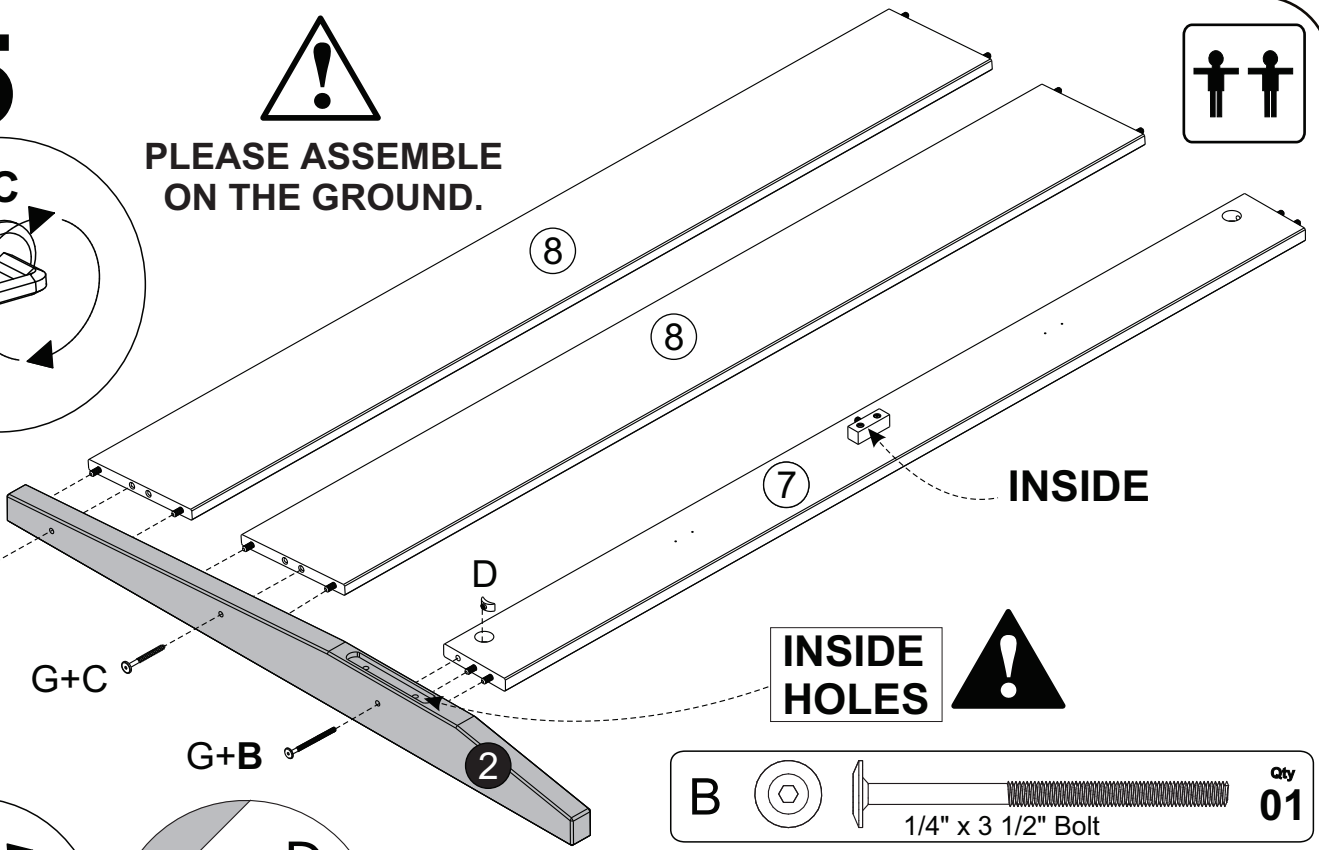
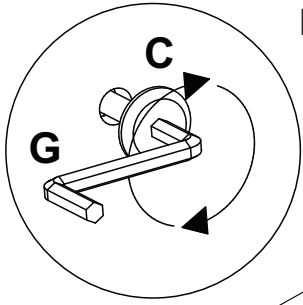

- |          |  |               |
|----------|--|---------------|
| <b>B</b> |  | Qty <b>01</b> |
| <b>C</b> |  | Qty <b>02</b> |
| <b>D</b> |  | Qty <b>01</b> |
| <b>G</b> |  | Qty <b>01</b> |

# 06

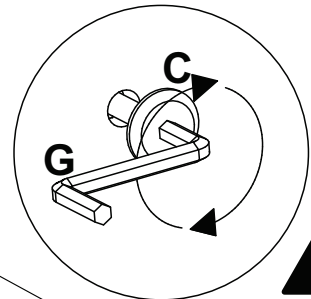

ATTENTION!

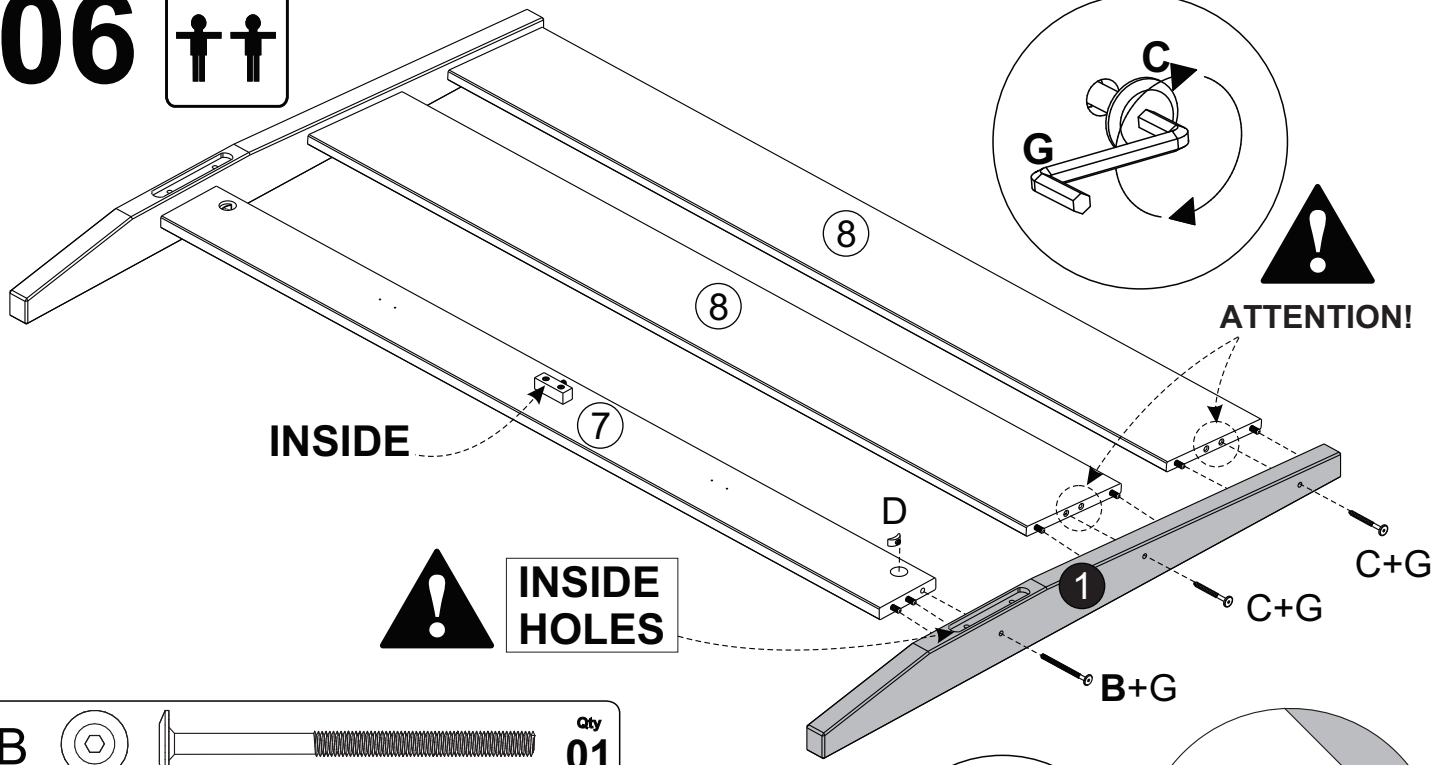

- |          |  |               |
|----------|--|---------------|
| <b>B</b> |  | Qty <b>01</b> |
| <b>C</b> |  | Qty <b>02</b> |
| <b>D</b> |  | Qty <b>01</b> |
| <b>G</b> |  | Qty <b>01</b> |

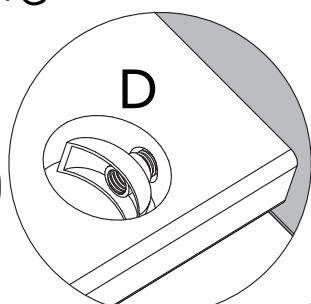
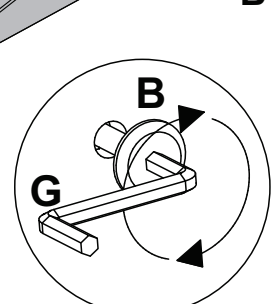

# 07

IN THIS STEP IS NECESSARY 2 PEOPLE TO AVOID DAMAGE. ONE TO ATTACH THE BOLTS ON THE HEADBOARD AND ONE TO HOLD THE OTHER END OF THE SIDE RAIL.



**MANUFACTURER LABEL**

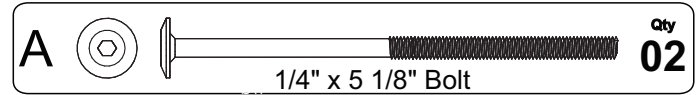
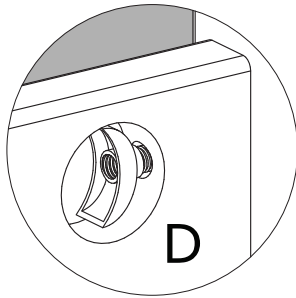
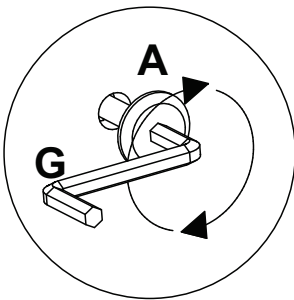
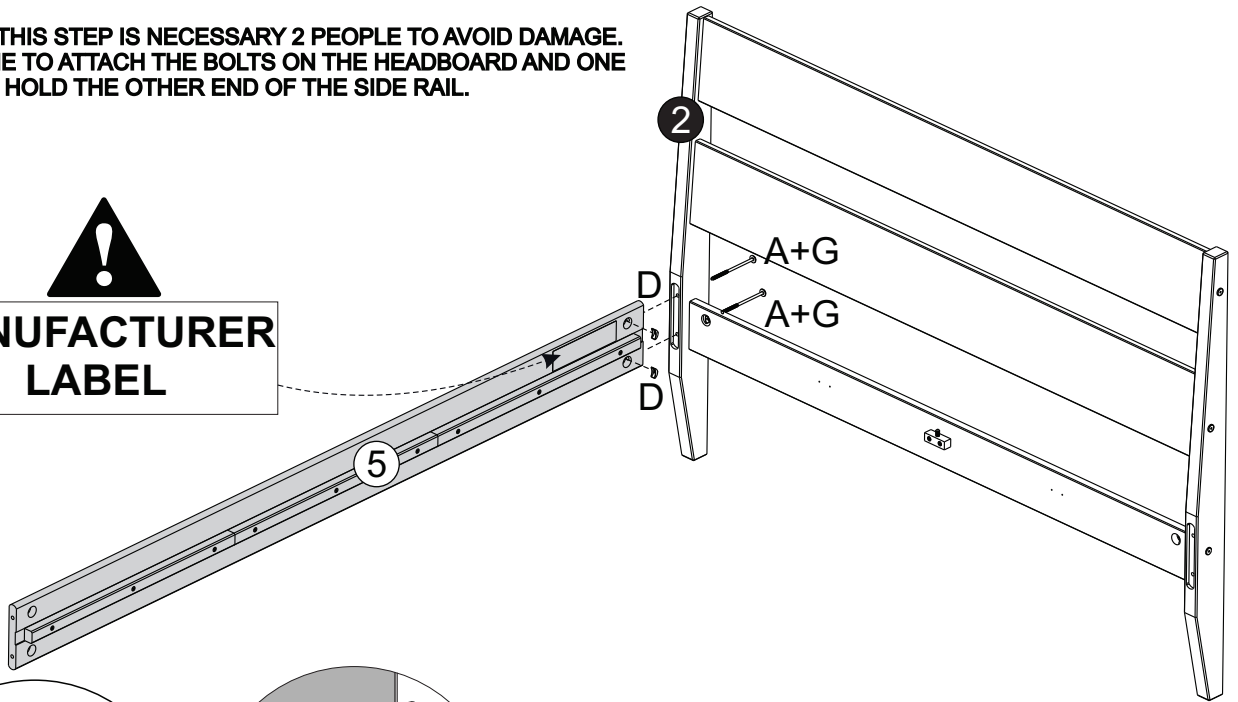

# 08

IN THIS STEP IS NECESSARY 2 PEOPLE TO AVOID DAMAGE. ONE TO ATTACH THE BOLTS ON THE HEADBOARD AND ONE TO HOLD THE OTHER END OF THE SIDE RAIL.

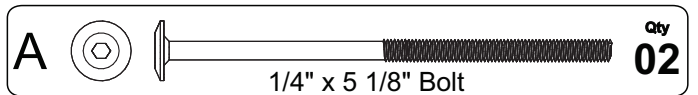
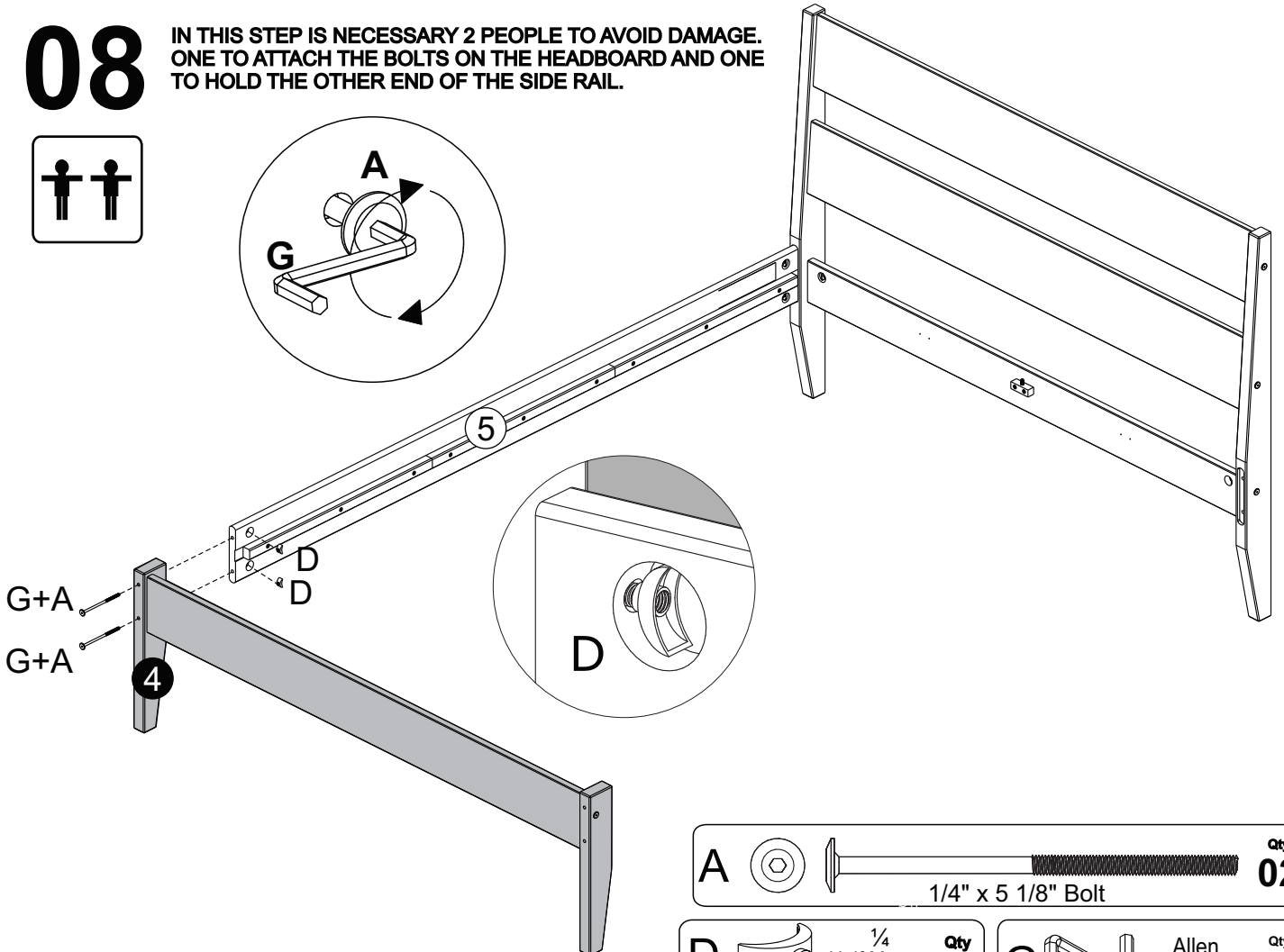
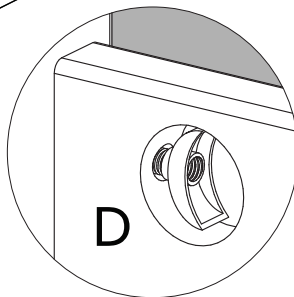
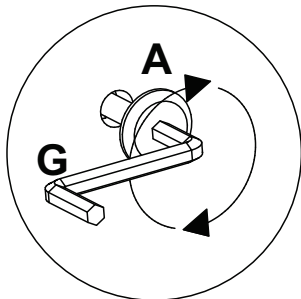

# 09



IN THIS STEP IS NECESSARY 2 PEOPLE TO AVOID DAMAGE. ONE TO ATTACH THE BOLTS ON THE HEADBOARD AND ONE TO HOLD THE OTHER END OF THE SIDE RAIL.

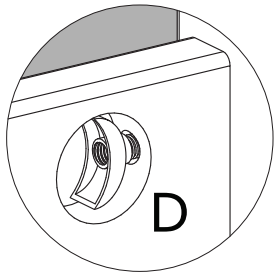
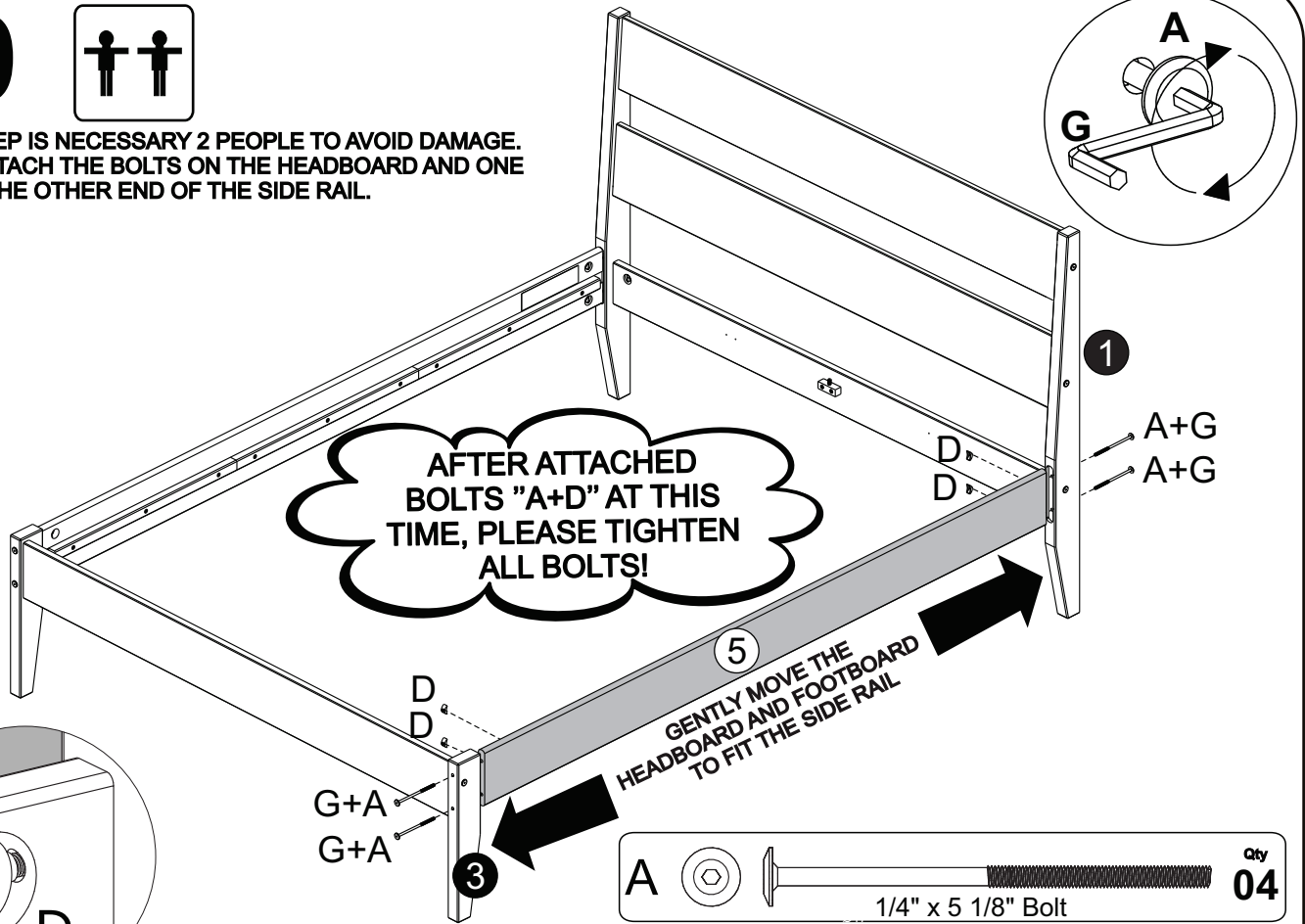

A		1/4" x 5 1/8" Bolt	Qty	04
---	--	--------------------	-----	----

D		1/4 Half Moon Nut	Qty	04
---	--	-------------------	-----	----

G		Allen Wrench	Qty	01
---	--	--------------	-----	----

# 10



PLEASE ASSEMBLE ON THE GROUND.

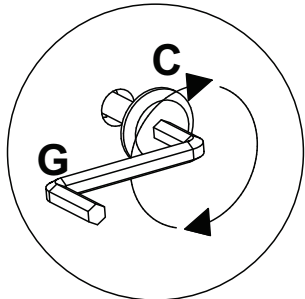
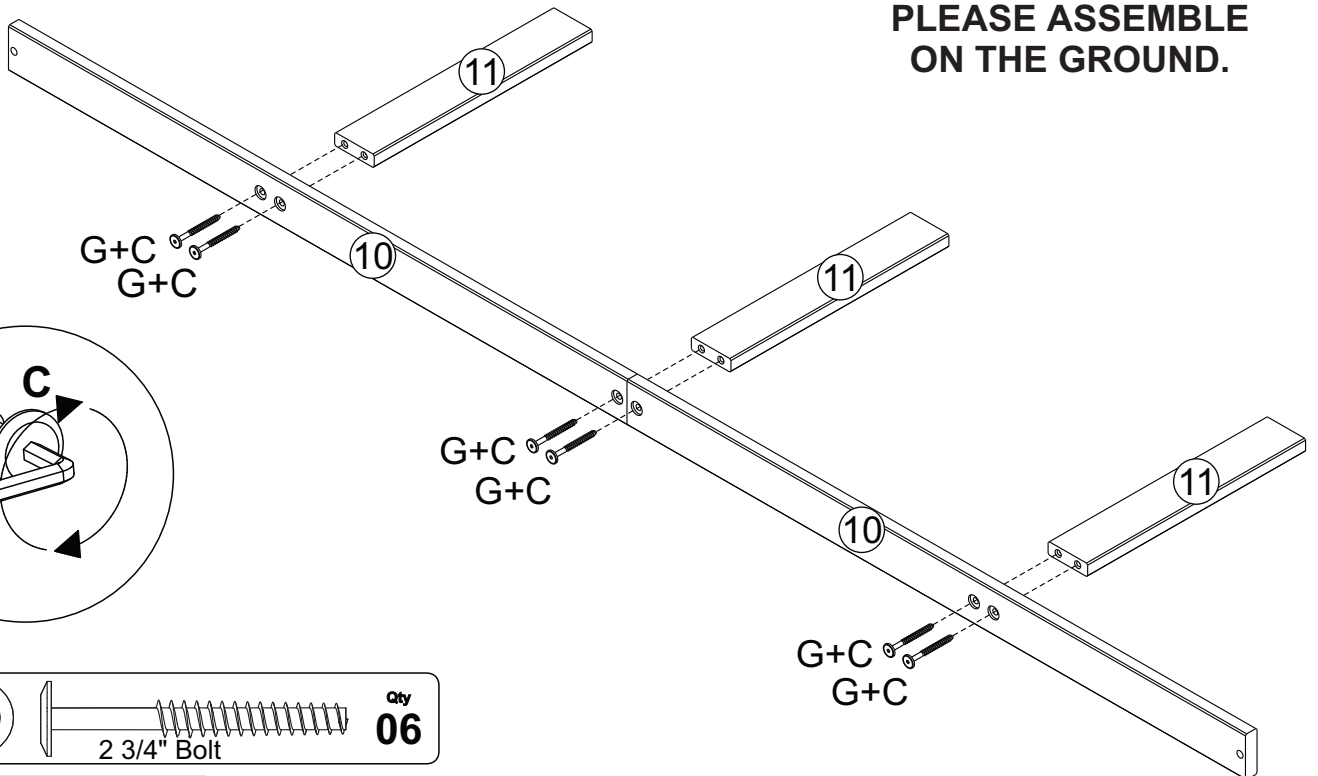

C		2 3/4" Bolt	Qty	06
---	--	-------------	-----	----

G		Allen Wrench	Qty	01
---	--	--------------	-----	----

# 11

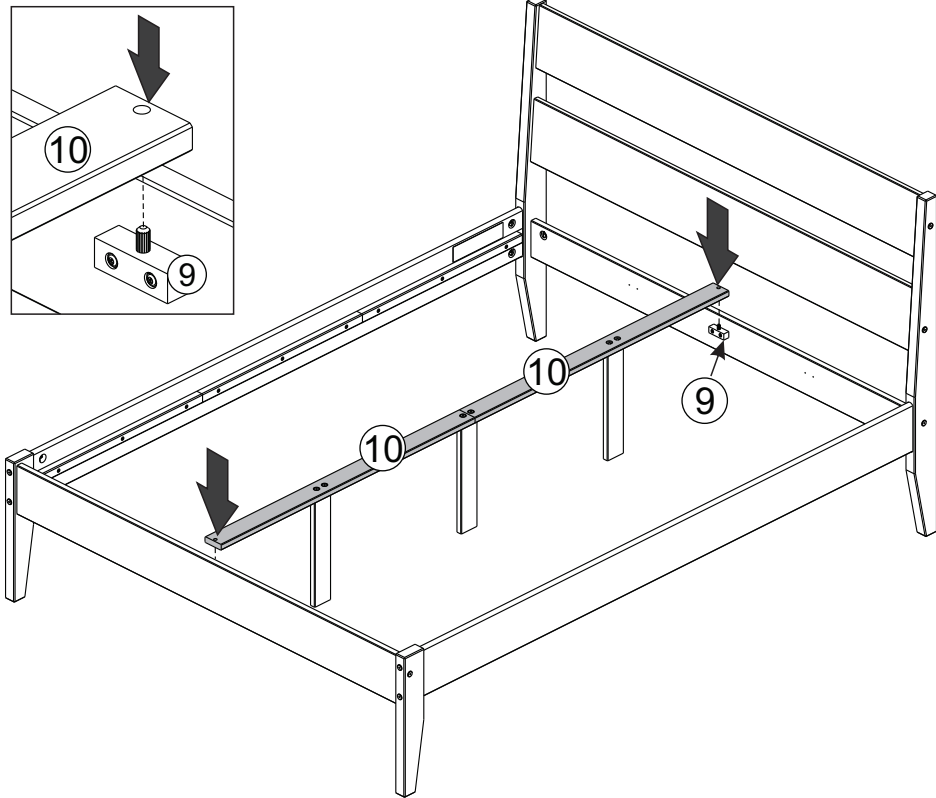

# 12

The first slats must be fixed to the end of the side rail bracket.

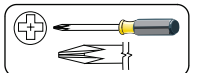
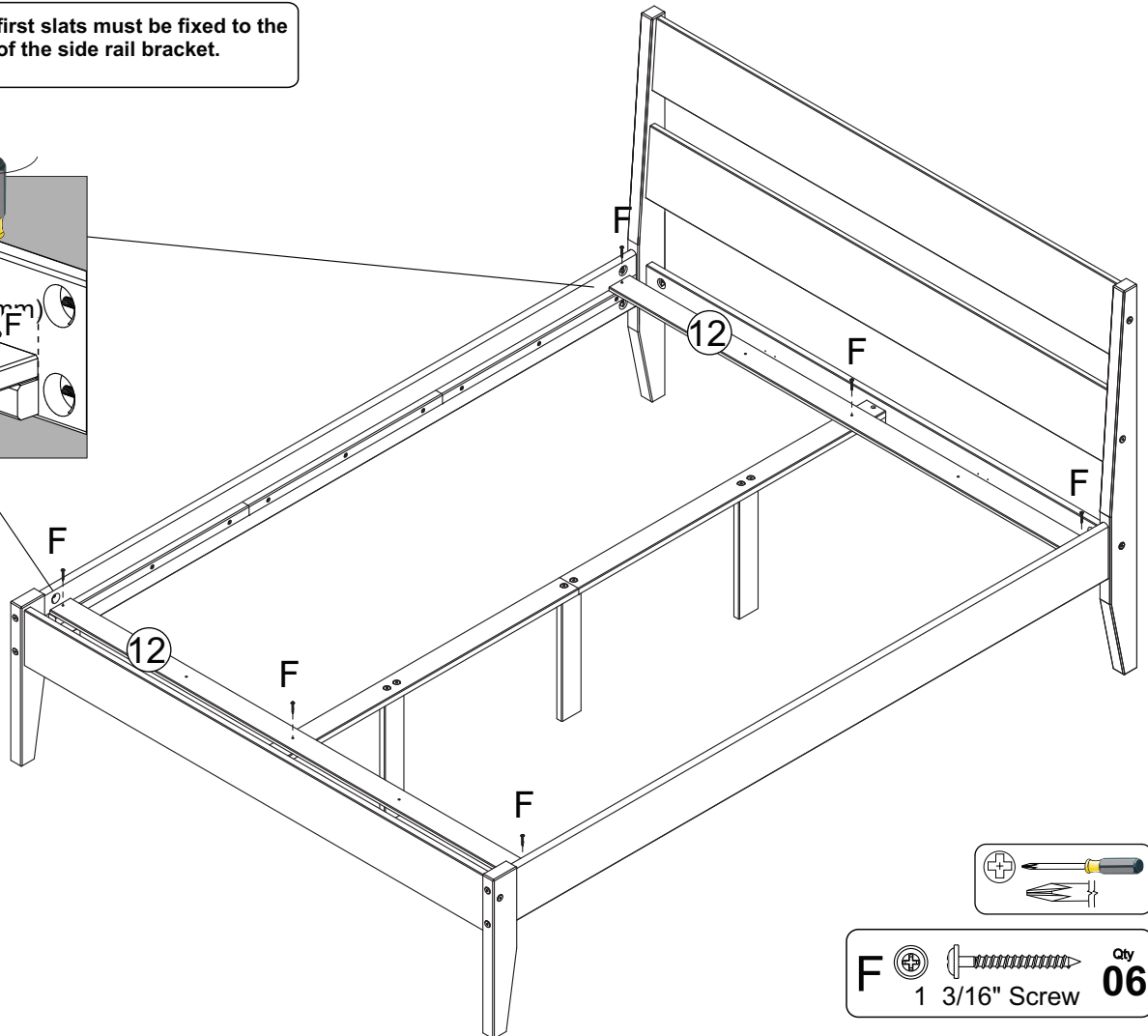
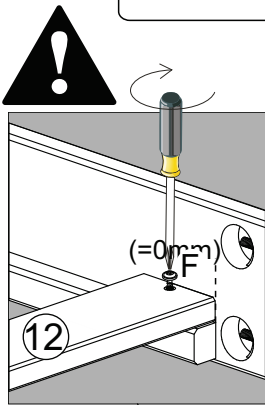

F  1 3/16" Screw Qty 06

# 13

## IMPORTANT NOTE:

Please note warpage may occur because it is natural wood. To facilitate the placement of the screws, you must press the two siderails simultaneously, as shown by the arrows.

Please refer to the diagram below for placement of the cross-slats

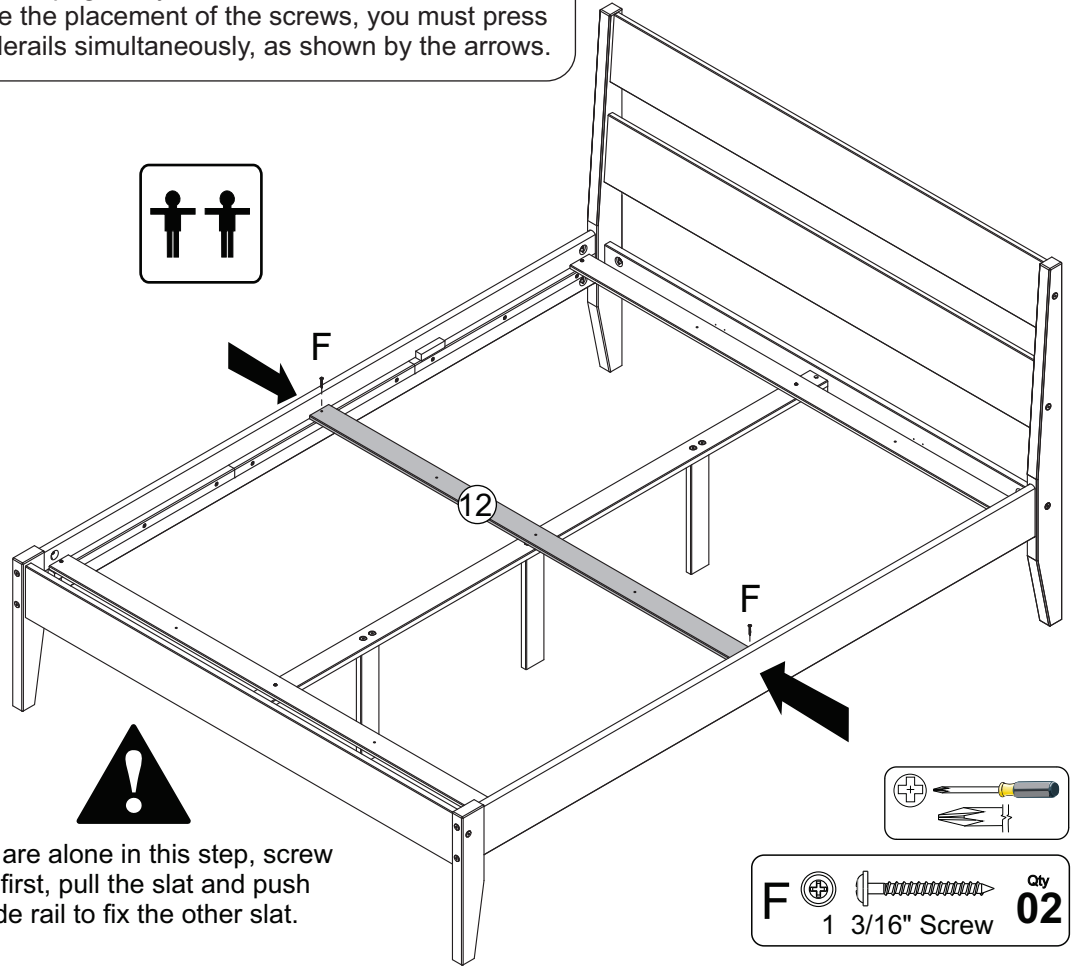
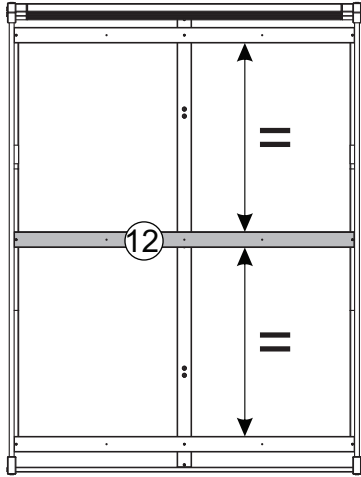

If you are alone in this step, screw 1 slat first, pull the slat and push the side rail to fix the other slat.

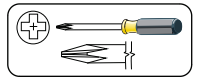

**F**  1 3/16" Screw Qty **02**

# 14

After fixed the first slat use the hardware letter "H" to help define the space between each next slats. Use 1- I on the left side rail and 1- I on the right side rail

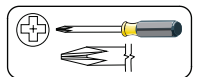
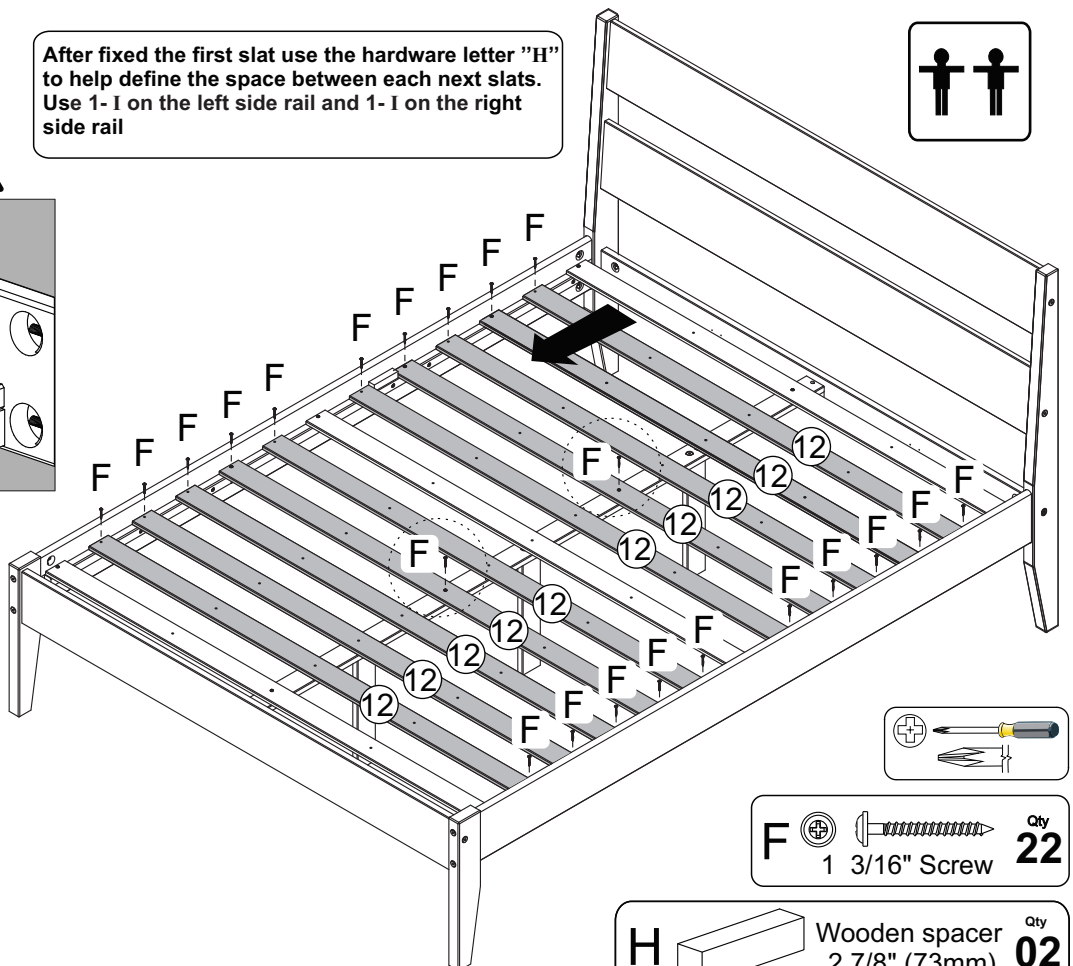
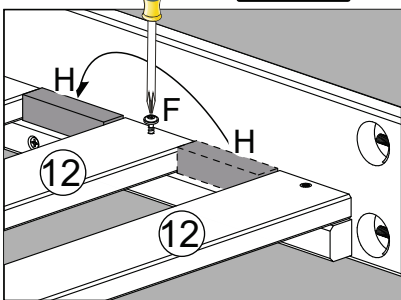
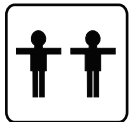

**F**  1 3/16" Screw Qty **22**

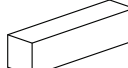
**H**  Wooden spacer 2 7/8" (73mm) Qty **02**

