

29R

21" ADA Solid Door Refrigerator • ADA Series



FEATURES & BENEFITS



BLACK SOLID



BLACK SOLID (LOCK)



WHITE SOLID



WHITE SOLID (LOCK)

PERFORMANCE	<ul style="list-style-type: none"> • Volume of 3.3 cu ft holds up to 35 bottles (12 oz) or 48 cans (12 oz) • Mechanical Dial Control is conveniently located on the grille • Temperature range: 34°F - 45°F • Passive cooling system
INTERIOR/EXTERIOR	<ul style="list-style-type: none"> • Three removable tempered glass shelves • Three fixed shelves in door • Door swing is field reversible for non-lock models, and is shipped right-hand hinged • Door lock models are available, and must be ordered hinge specific
INTEGRATION	<ul style="list-style-type: none"> • Unit is designed to be built-in or can be freestanding • Non-lock models accepts a 1/4" custom insert panel • Available in the following finishes: Black or White

MODEL DETAILS

Model	Voltage/Hz	Door Swing	Finish	Shipping Weight
U-29RB-00A	115 / 60	Field Reversible	Black Solid	89 lb
U-29RB-13A	115 / 60	Right-Hand Hinge	Black Solid (Lock)	89 lb
U-29RB-15A	115 / 60	Left-Hand Hinge	Black Solid (Lock)	89 lb
U-29RW-00A	115 / 60	Field Reversible	White Solid	89 lb
U-29RW-13A	115 / 60	Right-Hand Hinge	White Solid (Lock)	89 lb
U-29RW-15A	115 / 60	Left-Hand Hinge	White Solid (Lock)	89 lb

DIMENSIONS

Dimensions shown apply to all finishes.

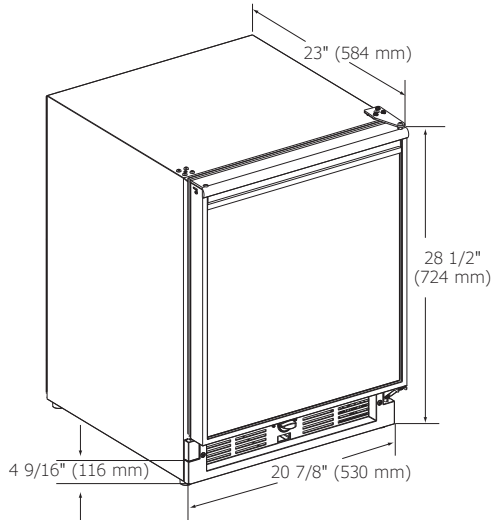

CABINET CUT-OUT

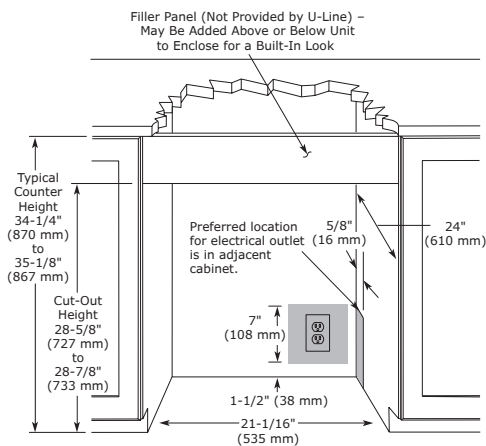

INSTALLATION NOTES

Cutout includes the additional 1/4" width overall to ensure proper installation.

No additional clearance around sides, top or rear of unit is needed for ventilation.

Do not obstruct front grille air flow.

SPECIFICATIONS

Model	29R
Amps: Running	1.2
Capacity: Bottle (12 oz)	35
Capacity: Can (12 oz)	48
Capacity: Volume (cu ft)	3.3
Control Type	Mechanical Dial
Dimensions: Product Depth	23" / 584 mm
Dimensions: Product Height	28 1/2" / 724 mm
Dimensions: Product Width	20 7/8" / 530 mm
Energy Consumption: Avg. Per Year	260 kWh
ENERGY STAR / CEE RATING	ENERGY STAR / Tier 1
Panel Thickness	1/4" (6.3 mm)
Panel Dimensions: Height	21 13/32" (544mm)
Panel Dimensions: Width	19 13/16" (503mm)
Product Weight: Max	80 lb
Refrigerant Type	R600a
Sabbath (Star K Certified)	No
Temperature Range	34°F - 45°F

COOLING SYSTEM



ELECTRICAL REQUIREMENTS

This unit requires a grounded, polarized 115 VAC, 60 Hz, 15 A power supply (normal household current).



Please visit u-line.com to view this model's User Guide & Service Manual. All Specifications are subject to change without notice.