

Use & Care Manual

Refrigerator



electrolux.com/register
electrolux.ca

2

INTRODUCTION

Thank you for choosing Electrolux. We are the progressive and premium home life brand, making desirable experiences more sustainable. This Use & Care Manual is part of our commitment to your experience for the life of your appliance.

Purchase date

Model number

Serial number

Introduction.....	2
Important Safety information	3
Features	6
Installation.....	8
Door Removal.....	10
Door Handle Installation	15
Water Supply Connection.....	16
Controls and Settings	19
Automatic Water Dispenser	21
Ice Maker.....	22
Storage Features	23
Storing Food and Saving Energy	29
Normal Operating Sounds	30
Filter Replacement.....	31
Care and Cleaning.....	34
Troubleshooting	36
Limited Warranty.....	41



NOTE

Registering your product with Electrolux enhances our ability to serve you. You can register online at Electrolux.com or by sending your Product Registration Card in the mail.



Installation Checklist

Doors

- Handles are secure and tight
- Door seals completely to cabinet on all sides

Leveling

- Appliance is level, side to side and slightly elevated in front to assist with door and drawer closing (front should be higher than back)
- Toe grille is properly attached to refrigerator
- Cabinet is placed solid on all corners

Electrical Power

- House power turned on
- Appliance plugged in

Ice Maker

- House water supply connected to appliance **WARNING: Potable water supply only.**
- No water leaks present at all connections - recheck in 24 hours
- Ice maker is turned ON
- Ice & water dispenser operates correctly

Final Checks

- Shipping material removed
- Refrigerator and freezer temperatures set
- Crisper humidity controls set



WARNING

Please read all instructions before using this appliance.

Safety Definitions

 This is the safety alert symbol. It is used to alert of potential personal injury hazards. Obey all safety messages that follow this symbol to avoid possible injury or death.



DANGER

DANGER indicates an imminently hazardous situation which, if not avoided, will result in death or serious injury.



WARNING

WARNING indicates a potentially hazardous situation which, if not avoided, could result in death or serious injury.



CAUTION

CAUTION indicates a potentially hazardous situation which, if not avoided, may result in minor or moderate injury.



IMPORTANT

IMPORTANT indicates installation, operation or maintenance information which is important but not hazard-related.



DANGER



DANGER Risk of fire or explosion. Flammable refrigerant used. Do not use mechanical devices to defrost refrigerator. Do not puncture refrigerant tubing.

DANGER Risk of fire or explosion. Flammable refrigerant used. To be repaired only by trained service personnel. Use only manufacturer-authorized service parts. Any repair equipment used must be designed for flammable refrigerants. Follow all manufacturer repair instructions. Do not puncture refrigerant tubing.



CAUTION



CAUTION Risk of fire or explosion. Dispose of refrigerator properly in accordance with the applicable federal or local regulations. Flammable refrigerant used.

CAUTION Risk of fire or explosion due to puncture of refrigerant tubing. Follow handling instructions carefully. Flammable refrigerant used.



WARNING

CALIFORNIA RESIDENTS ONLY
Cancer and Reproductive Harm
www.P65Warnings.ca.gov

4

IMPORTANT SAFETY INFORMATION

Child Safety

Destroy or recycle the carton, plastic bags, and any exterior wrapping material immediately after the refrigerator is unpacked. Children should **NEVER** use these items to play. Cartons covered with rugs, bedspreads, plastic sheets or stretch wrap may become airtight chambers, and can quickly cause suffocation.

Safety Instructions

- DO NOT store or use gasoline, or other flammable liquids in the vicinity of this or any other appliance. Read product labels for warnings regarding flammability and other hazards.
- DO NOT operate the refrigerator in the presence of explosive fumes.
- Avoid contact with any moving parts of automatic ice maker.
- Remove all staples from the carton. Staples can cause severe cuts, and also destroy finishes if they come in contact with other appliances or furniture.



WARNING

Do not use electrical appliances inside the food storage compartments of the appliance unless they are of the type recommended by the manufacturer.

Proper Disposal of your Appliance

Risk of child entrapment

Child entrapment and suffocation are not problems of the past. Junked or abandoned appliances are still dangerous – even if they will sit for “just a few days”. If you are getting rid of your old unit, please follow the instructions below to help prevent accidents.

We strongly encourage responsible appliance recycling/disposal methods. Check with your utility company or visit energystar.gov/recycle for more information on recycling your old refrigerator.

Before you throw away your old unit:

- Remove doors.
- Leave shelves in place so children may not easily climb inside.
- Have refrigerant removed by a qualified service technician.

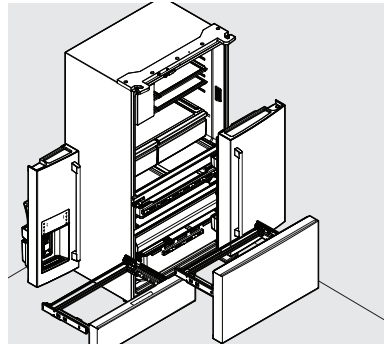



WARNING

You must follow these guidelines to ensure that your refrigerator's safety mechanisms are operating correctly.

Electrical information

- Plug the refrigerator into its own dedicated 115 Volt, 60 Hz., 15 Amp, AC only electrical outlet. The power cord of the appliance is equipped with a 3-prong grounding plug for your protection against electrical shock hazards. You must plug it directly into a properly grounded 3-prong receptacle. You must install the receptacle in accordance with local codes and ordinances. Consult a qualified electrician. Do not use an extension cord or adapter plug.
- If the power cord is damaged, an authorized service technician should replace it to prevent any risk.
- Never unplug the refrigerator by pulling on the power cord. Always grip the plug firmly, and pull it straight out from the receptacle to prevent damaging the power cord.
- Unplug the refrigerator before cleaning to avoid electrical shock.
- Performance may be affected if the voltage varies by 10% or more. Operating the refrigerator with insufficient power can damage the compressor. Such damage is not covered under your warranty.
- Do not plug the unit into an electrical outlet controlled by a wall switch or pull cord to prevent the refrigerator from being turned off accidentally.



IMPORTANT

To turn off power to your refrigerator you must unplug the power cord from the electrical outlet.

Grounding type wall receptacle

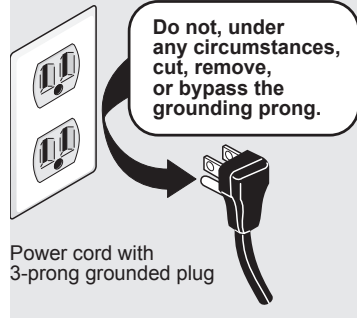

WARNING

When positioning the appliance, ensure the supply cord is not trapped or damaged.



WARNING

Do not locate multiple portable socket-outlets or portable power supplies at the rear of the appliance.

6

FEATURES

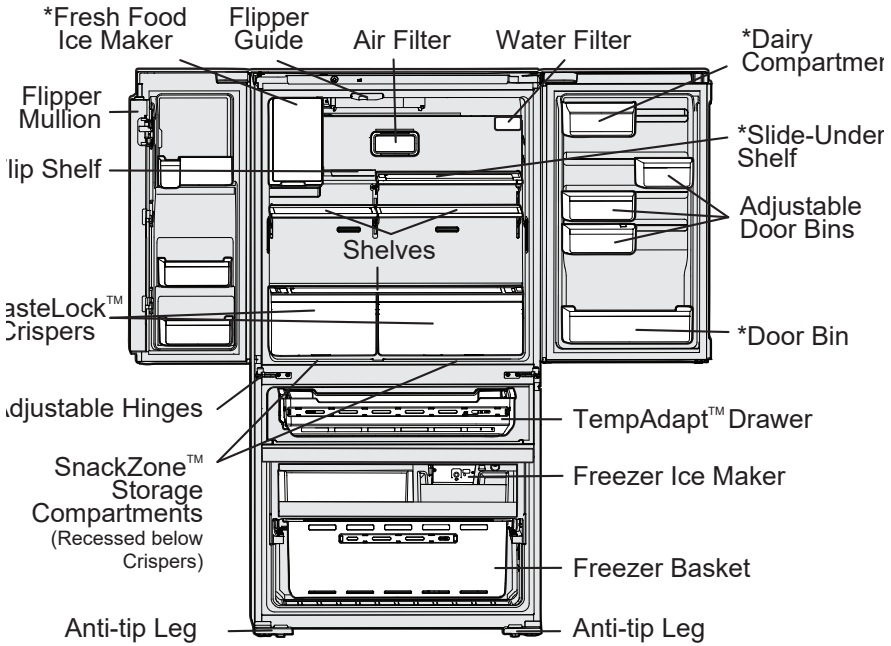

IMPORTANT

Accessories are available for your appliance and may be purchased at Electrolux.com, by calling 1-877-4ELECTROLUX (1-877-435-3287) or from an authorized seller.

Tools Necessary:

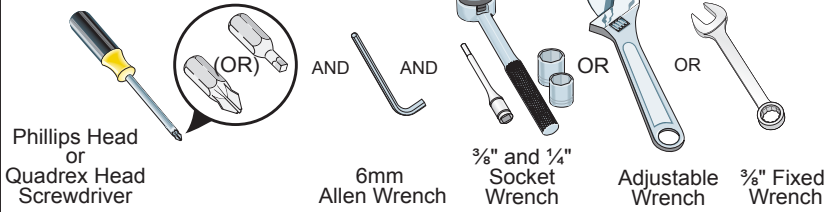

This Use & Care Manual provides general installation and operating instructions for your model. We recommend using a service or kitchen contracting professional to install your refrigerator. Use the refrigerator only as instructed in this Use & Care Manual.

Before starting the refrigerator, follow these important first steps.

Location

- **Do Not** use an extension cord or an adapter plug.
- If possible, place the refrigerator out of direct sunlight and away from the range, dishwasher, or other heat sources.
- You must install the refrigerator on a floor that is level and strong enough to support a fully loaded refrigerator.
- Consider water supply availability for models equipped with an automatic ice maker.



WARNING

This appliance is intended for use in residential household and similar interior applications such as:

- Kitchen / Kitchenette
- Pantry room
- Basement
- Enclosed garage
- Other interior residential-type environments



CAUTION

Do Not install the refrigerator where the temperature will drop below 55°F (13°C) or rise above 110°F (43°C). The compressor will not be able to maintain proper temperatures inside the refrigerator.

DO NOT block the toe grille on the lower front of your refrigerator. Sufficient air circulation is essential for the proper operation of your refrigerator.



WARNING

Installation

Allow the following clearances for ease of installation, proper air circulation, and plumbing and electrical connections:

- Sides & Top $\frac{3}{8}$ in. (9.5 mm)
- Back 1 in. (25.4 mm)



NOTE

If you place your refrigerator with the door hinge against a wall, you may have to allow additional space so you can open the door wider.

8

INSTALLATION

Cabinet Leveling & Door Alignment (if necessary)

Guidelines for final positioning of refrigerator:

- All four corners of the cabinet must rest firmly on the floor.
- Slightly elevate the front to ensure the doors close and seal properly.
- Align and level the doors with each other.

You can meet most of these conditions by raising or lowering the adjustable anti-tip legs.

To level the cabinet using the anti-tip legs:

- 1 Slightly open the freezer drawer.
- 2 Lower the anti-tip legs until they are both touching the floor. Use a pair of pliers to adjust.

To raise unit: turn leg clockwise.

To lower unit: turn leg counterclockwise.

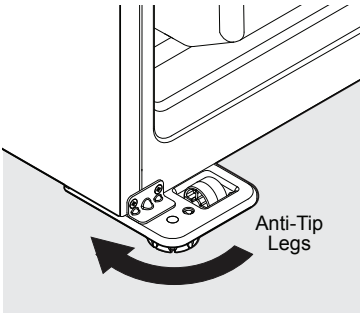

- 3 Ensure both doors are bind-free with their seals touching the cabinet on all four sides and the cabinet is stable.

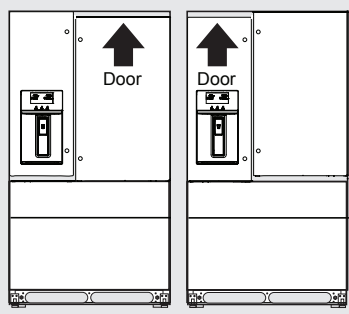

To make final door height adjustments:

1. Open TempAdapt drawer to make lower hinge visible.
2. Insert 6mm Allen wrench into the shaft of the lower hinge.

To lower door: turn adjustment screw clockwise.

To raise door: turn adjustment screw counterclockwise.

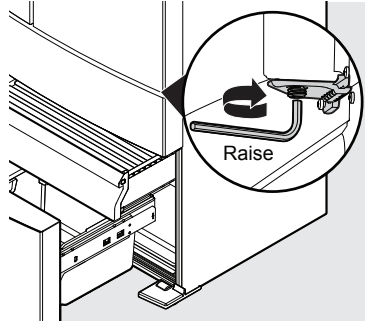

Flipper Mullion

Adjust the flipper mullion for proper connection with the mullion guide by ensuring the flipper mullion is folded and perpendicular to the fresh food door. If the mullion guide is not in the correct position, it could prevent the door from closing completely.

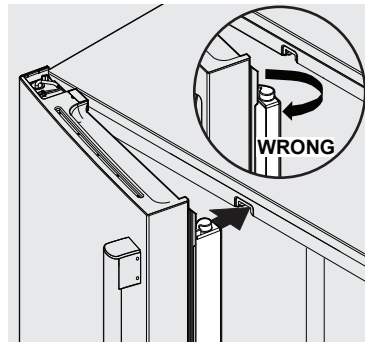

Getting through narrow spaces

If the refrigerator will not fit through an entrance area, you can remove the doors. Check first by measuring the entrance.

To prepare for removing the doors:

- 1 Make sure the electrical power cord is unplugged from the wall outlet.
- 2 Remove any food from the door shelves and close the doors.

To remove the refrigerator doors:

- 1 Open the doors to 90°.
- 2 Remove all five Phillips screws from the top hinge cover and lift it up.

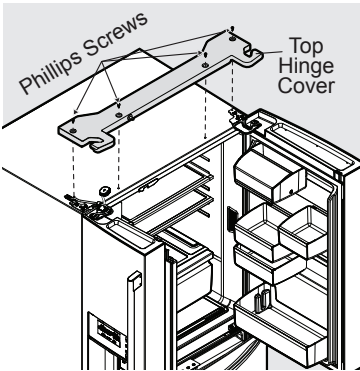

- 3 Trace lightly around the door's top hinges with a pencil. This makes reinstallation easier.
- 4 Disconnect the electrical harness running from the door to the hinge cover.

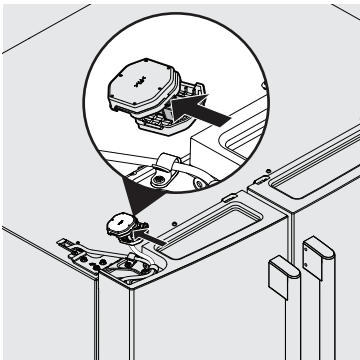

- 5 Pull up on the water line gently to remove from door.

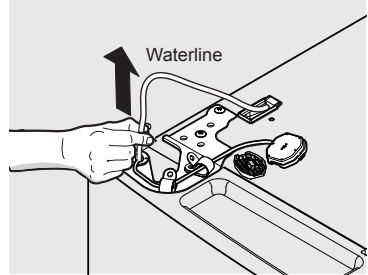

NOTE

Use care while pulling the water tube from the door to be sure that tube does not kink.

NOTE

You will pull approximately 4 ft. of water tube from the refrigerator door.

CAUTION

Be sure doors are set aside in a secure position where they cannot fall and cause personal injury, or damage to the doors or handles.

- 6 Remove three 8 mm bolts from both top hinges. Lift doors up off lower hinges and carefully set aside.

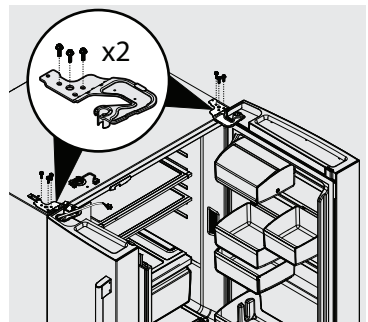

10

INSTALLATION

- 7 To gain access to lower hinge, extend the drawer. Unscrew the three lower hinge screws and slide the hinge inward.

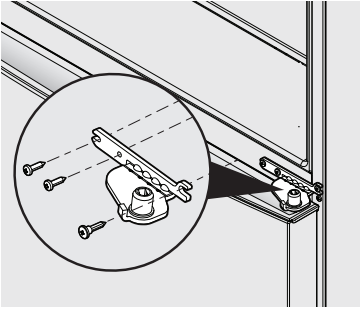

Lower Hinge Removal

- 8 To reinstall doors, reverse the procedure.



IMPORTANT

Make sure the water line tubing goes through the hole at the top of the dispenser pocket. There is also a metal wrap on the tubing to prevent damage from the hinge rubbing against it. Fix this part back around the tube in the proper location upon reinstallation (protecting the tube from the hinge).



NOTE

Be sure the tube does not kink when reinserting the water tube and replacing the top hinge cover.

Once both doors are in place, ensure they are aligned with each other and level (Reference **Cabinet Leveling & Door Alignment** for more details), and replace the top hinge cover.

NOTE

Optional Door Opening Angle Feature parts are identified:

LH - Left Hand, to apply on the Left Door

RH - Right Hand, to apply on the Right Door

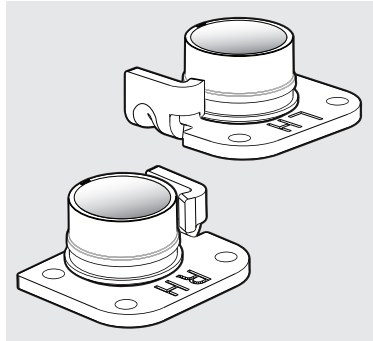

Optional Door Opening Angle Feature

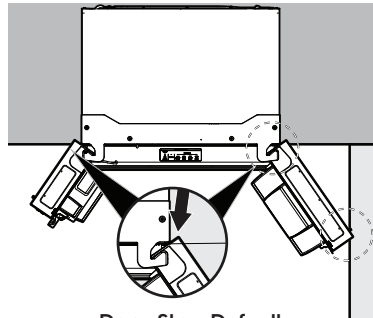

Door Stop Default
Maximum Opening Angle: 123°

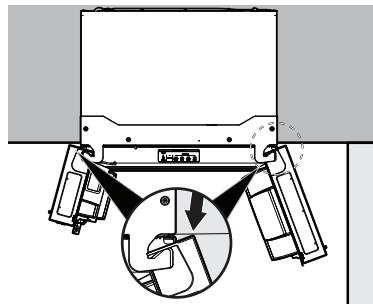

Optional Door Opening Angle Feature
Maximum Opening Angle: 105°

To prevent the doors from touching objects

If your refrigerator doors are touching objects such as a wall or countertop located close to the side of the appliance, the doorstop can be replaced with the provided **Optional Door Opening Angle Feature** located in your crisper drawer. This is to reduce the maximum door opening angle for both doors or one specific door.

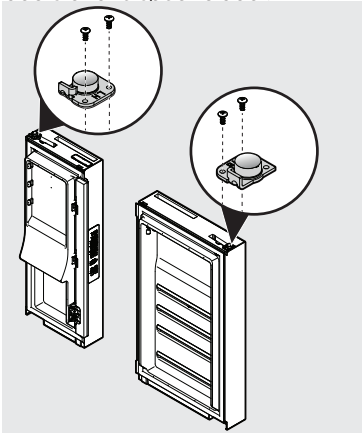

Door Stopper Removal

Once you remove the doors from the unit using the steps in **To remove the refrigerator doors in INSTALLATION**, perform the following steps to remove and replace the door stop:

1. Turn refrigerator door upside down to access the door stop located in the hinge area of the door.
2. Remove the two screws from the door stop.
3. Replace the door stop with the **Optional Door Opening Angle Feature**. Insert the two screws and retighten to secure the **Feature** to the hinge assembly.
4. Repeat the process for the opposite refrigerator door.
5. Reinstall the doors to the cabinet.

To remove the TempAdapt Drawer

- 1 Fully open the drawer.
- 2 Remove the basket from the drawer.
- 3 Unsnap the four cable ties by pressing the clip sides together and pushing through opening.

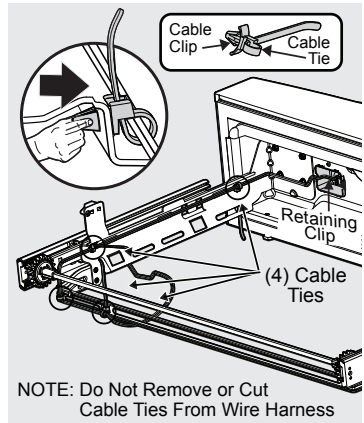
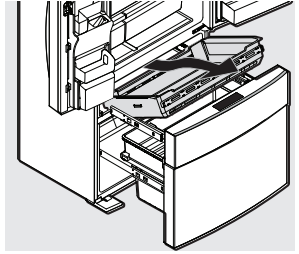

- 4 Remove the screw and the retaining clip, and disconnect the harness.

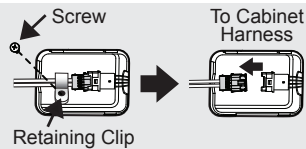

- 5 Remove the drawer by pressing on the liner clips and slide the rail past clips on both sides to fully remove the drawer from the cabinet.

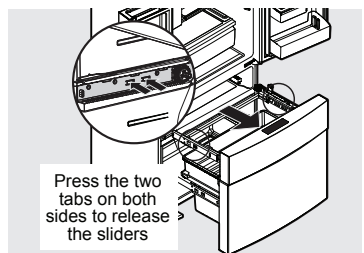

12 INSTALLATION

To reinstall the TempAdapt drawer

- 1 Place the drawer with the brackets and sliders inside the compartment and click the sliders into place on each side.

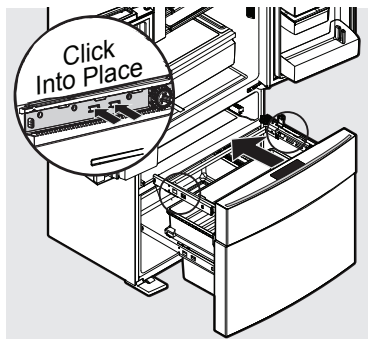

- 2 Reconnect the cabinet harness.
- 3 Replace the retaining clip and secure it with the screw.

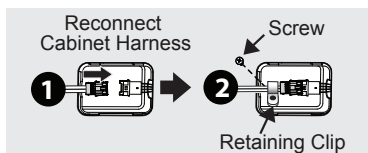

- 4 Reattach the electrical harness by positioning the cable clips over the black markings on the harness and push the 4 cable clips through openings in rail to secure harness in place.

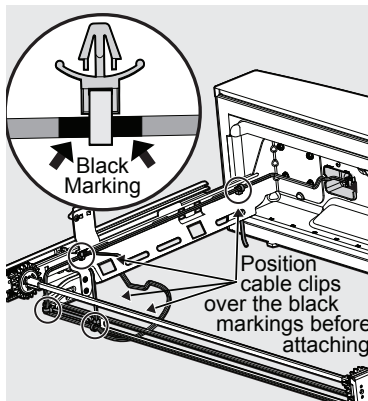

- 5 Slide the basket into place.
- 6 Close the drawer.

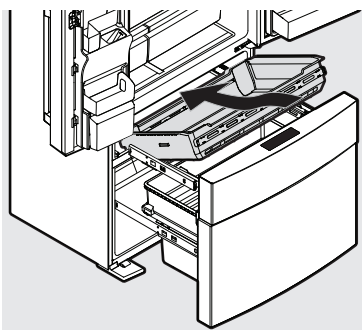

To remove the freezer drawer



CAUTION

The drawer is heavy. Use caution when lifting.

- 1 Open the drawer and fully extend it.
- 2 Remove the freezer drawer.
- 3 Remove the freezer basket.
- 4 Inside the cabinet, press the two tabs on both sides to release the sliders.
- 5 Remove the drawer with the brackets and sliders.

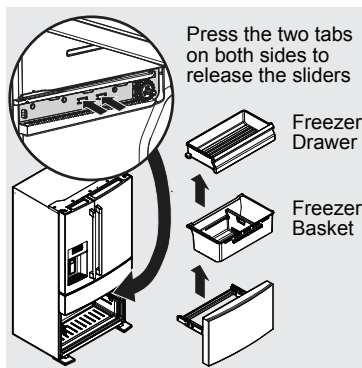

To reinstall the freezer drawer

- 1 Place the drawer with the brackets and sliders inside the cabinet and click it into place.
- 2 Replace the basket.



NOTE

For additional instructions, see **STORAGE FEATURES**.

**CAUTION**

Wear gloves and safety goggles. Use extreme CAUTION when installing these handles.

Door Handle Mounting Instructions

- 1 Remove the handles and any other protective packaging from the carton.
- 2 Position the fresh food handle end caps over the upper and lower pre-installed shoulder bolts (A) fastened into the door, ensuring the holes for the set screws are facing the opposite door.
- 3 While holding the handle firmly against the door, fasten the upper and lower Allen set screws (B) with supplied Allen wrench.
- 4 Repeat steps 2 and 3 to install the opposite handle. Ensure the holes for the set screws are facing the first door.

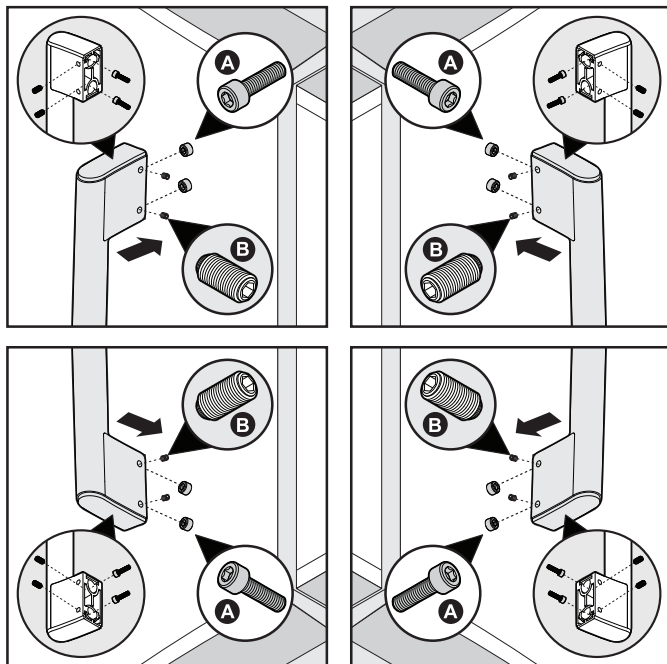
Mounting Refrigerator Handles**NOTE**

When tightening the Allen set screws, apply force to the longer arm of the Allen wrench supplied in the handle packaging.

**NOTE**

Tighten all set screws so the screw is below the surface of the handle. Draw the handles tight to the doors/drawer with no gaps. Opening the opposite door while tightening the Allen screw makes installation easier.

The door handles may loosen over time or if you improperly installed them. If this happens, tighten the set screws on the handles.

**WARNING**

To avoid electric shock, which can cause death or severe personal injury, disconnect the refrigerator from electrical power before connecting a water supply line to the refrigerator.

**CAUTION**

To Avoid Property Damage:

- We recommend using Stainless Steel braided tubing for the water supply line. We do not recommend using water supply tubing made of $\frac{1}{4}$ inch plastic. Plastic tubing greatly increases the potential for water leaks, and the manufacturer will not be responsible for any damage if you use plastic tubing for the supply line.
- **DO NOT** install water supply tubing in areas where temperatures fall below freezing.
- Chemicals from a malfunctioning softener can damage the ice maker. If the ice maker is connected to soft water, ensure the softener is maintained and working properly.

**IMPORTANT**

Ensure your water supply line connections comply with all local plumbing codes.

Before installing the water supply line, you will need:

1. Basic Tools: adjustable wrench, flat-blade screwdriver, and Phillips screwdriver
2. Access to a household cold water line with water pressure between 30 and 100 psi.
3. A water supply line made of $\frac{1}{4}$ inch (6.4 mm) OD copper or braided stainless steel tubing. To determine the length of tubing needed, measure the distance from the ice maker inlet valve at the back of the refrigerator to your cold water pipe. Then add approximately 6 feet (1.8 meters), so you can move the refrigerator out for cleaning.
4. A shutoff valve to connect the water supply line to your household water system.

**NOTE**

Check with your local building authority for recommendations on water lines and associated materials prior to installing your new refrigerator. Depending on your local/state building codes, we recommend, for homes with existing valves, Smart Choice® water line kit 5305513409 with a 6 ft. (1.8 meters) Stainless Steel Water Line, and for homes without an existing valve, we recommend Smart Choice® water line kit 5305510264 with a 20 ft. (6 meters) Copper Water Line with self-tapping saddle valve). Please refer to Electrolux.com for more information.

**NOTE**

Expect the first ice harvest within the first 24 hours of unit operation. To prevent any issues concerning ice production, please prime all water lines. See **Priming the water supply system** in the **AUTOMATIC ICE & WATER DISPENSER** section.

Connection to Household Water Supply with $\frac{1}{4}$ " compression fitting

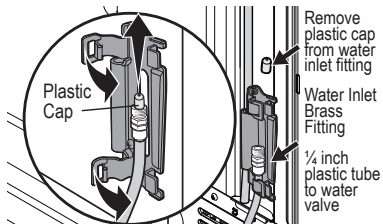
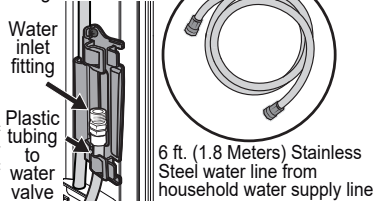

To Connect Water Tube to Household Water Supply

1. Disconnect the refrigerator from the electrical power source.
2. Place the end of the water supply line into a sink or bucket. Turn ON the water supply and flush the supply line until the water is clear. Turn OFF the water supply at the shutoff valve.

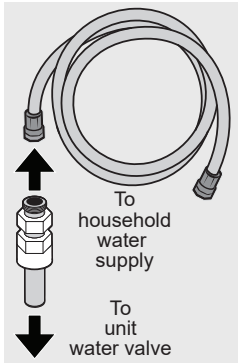

3. Open the locking clips and grab the water line coming from the refrigerator. Remove the plastic cap from the water inlet fitting and discard the cap.
4. If you are using (recommended) stainless steel braided tubing - the nut and ferrule are already assembled on the tubing. Slide the compression nut onto water inlet fitting and finger tighten.

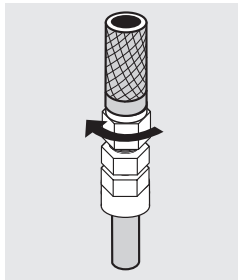

5. Using two ½ inch wrenches (one to hold the household water line nut and the other to hold the water inlet fitting nut), tighten a half turn with a wrench. DO NOT overtighten.

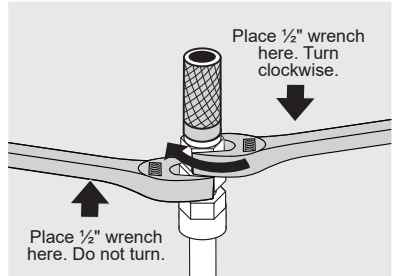

6. Replace the connected tubes into the clips and lock the clips back in place to keep the tubing in the right position.
7. Turn ON the water supply at the shutoff valve and tighten any leaking connections.
8. Reconnect the refrigerator to the electrical power source.
9. Ensure the ice maker is turned ON.
10. Purge air from the ice and water dispenser system by operating the water dispenser for 3-4 minutes. This will require dispensing several glasses of water.

External Ice and Water Dispenser Control

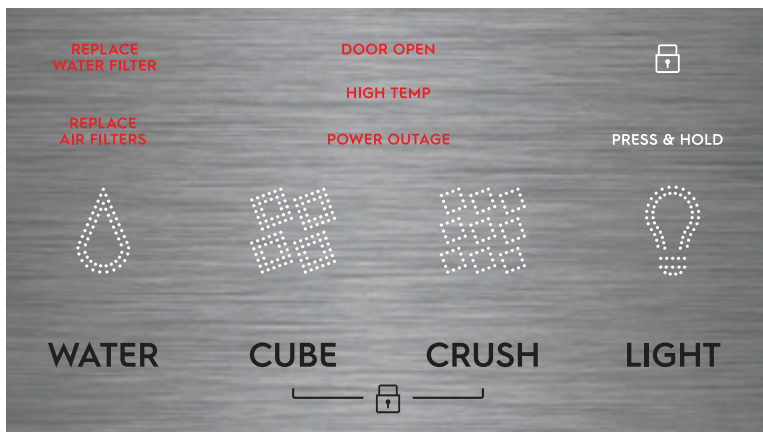
**REPLACE WATER FILTER**

When illuminated, indicates it is time to replace the water filter.

REPLACE AIR FILTER

When illuminated, indicates it is time to replace the air filter.

WATER

Press **WATER** to select water.

CRUSH

Press **CRUSH** to select crushed ice.

CUBE

Press **CUBE** to select cubed ice.

LOCK

Press and hold **CUBE** and **CRUSH** simultaneously for 3 seconds to LOCK/UNLOCK the appliance control display. When the display is locked, you cannot dispense water or ice, and the lock icon illuminates on the display.

LIGHT

Press **LIGHT** to select the light feature.

Appliance Control Display Mode Views

Your appliance control display is equipped with a sleep and lock mode to prevent accidental changes to the unit settings when opening and closing the doors. When both doors are closed, the display is in sleep mode. When you first open either door, the display is in lock mode where all the current settings are visible but dimmed.

Pressing any button on the display awakens the display and a tone plays. All settings will then fully light up. Touch the display again to change any setting.

If you press no button for 10 seconds while any door is open, the display defaults back to lock mode.

Awake Mode View

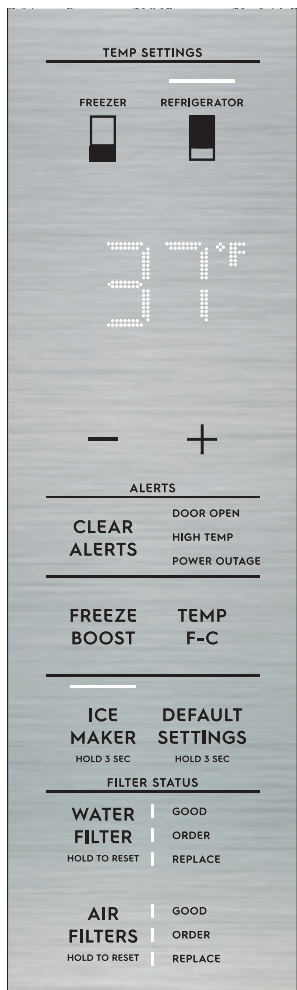

Lock Mode View

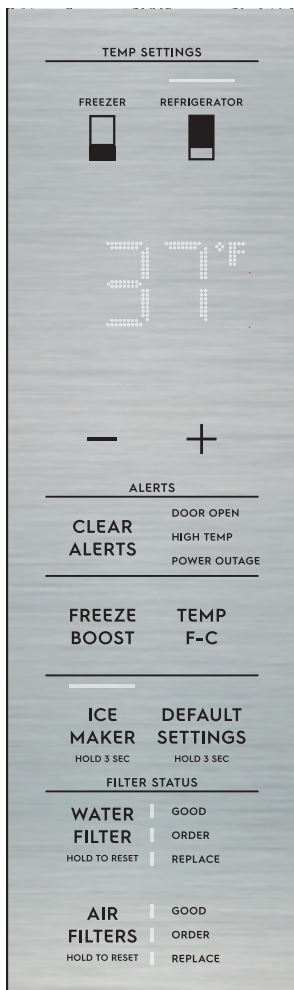

Sleep Mode View

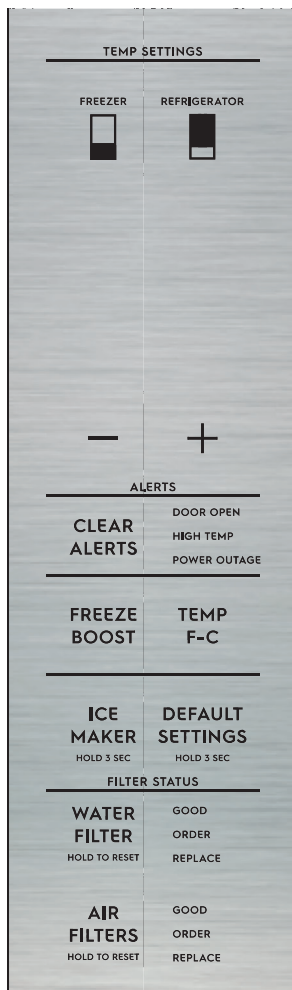

In-Door Appliance Control Display

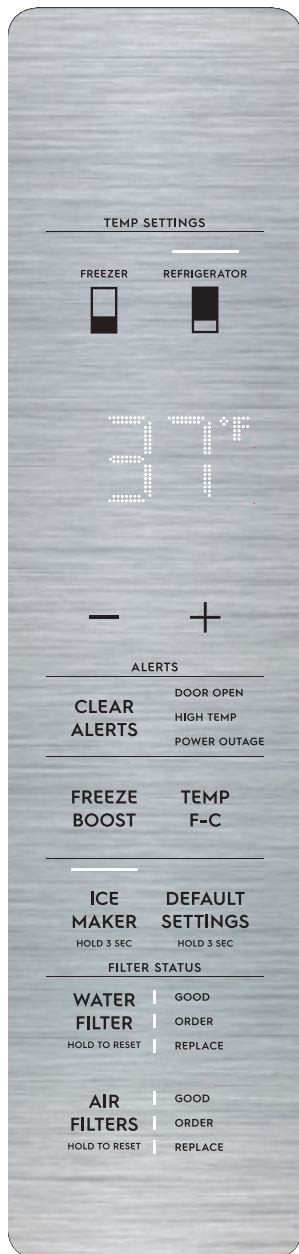
**TEMP SETTINGS**

Select the compartment for temperature change (**FREEZER** OR **REFRIGERATOR**). Press either + or – to adjust to the desired temperature setting.

Freezer temp - Control temperatures range from -6°F / -21°C to 6°F / -15°C.

Refrigerator temp - Control temperatures range from 34°F / 1°C to 44°F / 7°C. This unit is designed to operate at 37°F Refrigerator / 0°F Freezer. The unit should stabilize temperatures within 24 hours of installation.

CLEAR ALERTS

Resets any active and lit alarms on the appliance control display (**DOOR OPEN, HIGH TEMP, POWER OUTAGE**).

FREEZE BOOST

Prior to grocery shopping, we recommend you activate **FREEZE BOOST** to freeze your food faster. It remains active for up to 24 hours before automatically deactivating or you manually exit. Press **FREEZE BOOST** to turn the function off. This resets the freezer to the previous temperature setting.

TEMP F-C

Press to toggle between F & C.

ICE MAKER

For the ice maker inside the refrigerator, press and hold for 3 seconds to turn the ice maker on/off. When the indicator is lit, the ice maker is on. When the indicator is not lit, the ice maker is OFF and stops making ice. When the ice maker is off and you select **CRUSH** or **CUBE**, the **CRUSH** or **CUBE** indicator blinks twice. While off, ice dispensing can continue as long as there is ice in the bucket. When ice maker is off and ice is dispensing, the indicator blinks.

DEFAULT SETTINGS

Press and hold for 3 seconds to reset to default settings.

WATER FILTER

The status is shown at the right of the button. After replacing the filter, press and hold for 3 seconds to reset. The status resets to **GOOD**.

AIR FILTERS

The status is shown at the right of the button. After replacing the filter, press and hold for 3 seconds to reset. The status resets to **GOOD**.

 **NOTE**

Appliance control features and alarms may vary by model.

Alarms

Power Outage In the event of a power failure, the power outage alert illuminates once power has been restored and a tone sounds. The alert illuminates only if the refrigerator or freezer reached unsafe temperatures during the outage. Press any button to silence the tone.

Water Filter You need to replace the water filter when illuminated in red. Change the water filter every 6 months or when you have dispensed 125 gallons of water. To reset, press and hold **WATER FILTER** for 3 seconds.

Air Filter You need to replace the air filter when illuminated in red. Change the air filter every 6 months. To reset, press and hold **AIR FILTERS** for 3 seconds.

Door If a door has been left open for five minutes or more, an alarm sounds and **DOOR OPEN** illuminates on the display. Clear the alarm by pressing **CLEAR ALERTS**. The appliance control display returns to normal operations after you close the door.

Error Tone An alarm sounds if you try to make an unavailable selection.

High Temperature In the event of a high temperature condition, an alarm sounds. **HIGH TEMP** displays on the appliance control for the compartment with the high temperature (either the refrigerator or the freezer LED illuminates). The alarm sounds every 60 seconds, until acknowledged. Reset the alert by pressing **CLEAR ALERTS**.

Sabbath Mode

The Sabbath Mode disables portions of the refrigerator and its controls in accordance with weekly Sabbath observance and religious holidays within the Orthodox Jewish community.

Sabbath Mode is turned ON and OFF by simultaneously pressing and holding both — and **TEMP F-C** for five seconds. Other than the High Temp alarm, no audible sounds occur until the user exits the Sabbath mode. The display shows **Sb** while in Sabbath mode.

In the Sabbath Mode, the High Temp alarm is active for health reasons. For example, if the door is left ajar the High Temp alarm is activated. The refrigerator will function normally once the door is closed, without any violation of the Sabbath/Holidays. The High Temp alarm sounds when the cabinet temperature is outside the safe zone for 20 minutes. The alarm silences itself after 10 minutes while the **HIGH TEMP** stays lit until you exit the Sabbath mode.



For further assistance, guidelines for proper usage and a complete list of models with the Sabbath feature, please visit the web at star-k.org.

 **NOTE**

While in Sabbath Mode, neither the lights, dispenser, nor the appliance control display work until you deactivate Sabbath Mode.

The refrigerator stays in Sabbath Mode after power failure recovery. You must deactivate it with the buttons on the appliance control display.

 **NOTE**

Although the Sabbath Mode has been initiated, the ice maker completes the cycle it had already started. The ice cube compartment remains cold, and you can make new ice cubes with standard trays.

Fresh Food Ice Maker

To use the ice maker after installation

Before making ice for the first time, be sure to prime the water supply system. Air in new plumbing lines can result in two or three empty ice maker cycles. Furthermore, if you do not flush the system, the first ice cubes may be discolored or have an odd flavor.

Priming the water supply system



CAUTION

For proper dispenser operation, the recommended water supply pressure should fall between 30 psi and 100 psi. Excessive pressure may cause the water filter to malfunction.

- 1 Begin filling the filter by pressing and holding a drinking glass against the water dispenser paddle.
- 2 Keep the glass in this position until water comes out of the dispenser. It may take about 1½ minutes.
- 3 Continue dispensing water for about three minutes to flush the system and plumbing connections of any impurities (stopping to empty the glass as necessary).



NOTE

The water dispenser has a built-in device that shuts off the water flow after two minutes of continuous use. To reset this shutoff device, simply release the dispenser paddle.

Ice maker operation and care

After the refrigerator is properly installed and has cooled for several hours, the ice maker can start producing ice within 24 hours. The ice maker fills the ice bin from the rear. You must dispense some ice to force the ice forward in the bin. Expect a full bin after 48 to 60 hours with no ice use. The Ice rate is 2.0 to 2.5 pounds per day. The ice bin will hold about 4 pounds of ice.



IMPORTANT

Your ice maker is turned on at the factory so it can work as soon as you install your refrigerator. If you cannot connect a water supply, set the ice maker to **Off** and turn off the water supply valve; otherwise, the ice maker's fill valve may make a loud chattering noise when it attempts to operate without water.



NOTE

After the initial 26 ounces (750 ml), the water remains room temperature until the tank has refilled and been given enough time to chill the next 26 ounces (750 ml) of water. It may take up to 8 hours to chill.

To turn the fresh food ice maker on and off

Turn the ice maker on and off with the ice maker's On/Off icon on the appliance control display. Press and hold the ice maker button on the side display for three seconds to turn the ice maker on or off. The ice maker is on when the LED indicator illuminates.



IMPORTANT

Turning off the ice maker stops ice production only.



NOTE

The ice maker has a built-in signal arm that automatically stops ice production when the ice bin is full. Do not use this signal arm to manually stop the ice maker.



IMPORTANT

On occasion, you may notice unusually small ice cubes in the bucket or in dispensed ice. This could occur in normal operation of the ice maker. If you start seeing these more frequently, it may be an indication of low water pressure or you need to replace the water filter. As the water filter nears the end of its useful life and becomes clogged with particles, less water is delivered to the ice maker during each cycle. Remember, if it's been six months or longer since you last changed your water filter, replace the water filter with a new one. Poor quality household water may require the filter to be changed more frequently.

Ice maker/dispenser tips

- If your refrigerator is not connected to a water supply or the water supply is turned off, turn off the ice maker by holding the On/Off soft-touch icon for three seconds.
- The following sounds are normal when the ice maker is operating:
 - Motor running
 - Ice dropping into ice bin
 - Water valve opening or closing
 - Running water
- If you need a large quantity of ice at one time, it is best to get cubes directly from the ice bin.
- Ice cubes stored too long may develop an odd flavor. Empty the ice bin as explained below.
- When dispensing cubed ice, it is normal to have a small quantity of little pieces along with the whole cubes.



CAUTION

If the water supply to your refrigerator is softened, be sure the softener is properly maintained. Chemicals from a water softener can damage the ice maker.

Cleaning the ice maker

Clean the ice maker and ice bin at regular intervals, especially prior to vacation or moving.

- 1 Turn off the ice maker.
- 2 To remove the ice bin, (1) lift upward and (2) pull bin straight out

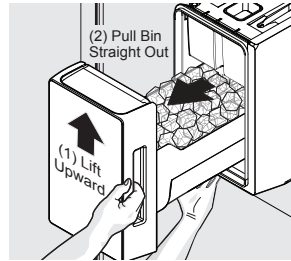

- 3 Empty and carefully clean the ice bin with mild detergent. Do not use harsh or abrasive cleaners. Rinse with clear water.
- 4 Allow the ice bin to dry completely before replacing.
- 5 Replace the ice bin. Turn the ice maker on.

Remove and empty the ice bin if:

- An extended power failure (one hour or longer) causes ice cubes in the ice bin to melt and freeze together, jamming the dispenser mechanism.
- You do not use the ice dispenser frequently. Ice cubes will freeze together in the bin, jamming the dispenser mechanism.

Remove the ice bin and shake to loosen the cubes or clean as explained above.



CAUTION

NEVER use an ice pick or similar sharp instrument to break up the ice. This could damage the ice bin.

To loosen stuck ice, use warm water. Before replacing the ice bin, make sure it is completely dry.

Freezer Ice Maker (select models)

Ice maker operation and care

After you have properly installed the refrigerator, the ice maker can produce ice within 24 hours. When using the ice maker for the first time, and in order for it to work properly, you need to clear air from the water tubing and the filter. Furthermore, if you do not flush the system, the first ice cubes may be discolored or have an odd flavor. Once the ice maker begins making ice, allow the bin to fill completely, and then discard the first FULL bin of ice.

Ice Maker and Storage Bin Capacity

This ice maker should produce between 2 and 2.5 pounds of ice per 24 hours depending on usage conditions. The ice bin will hold about 4.5 pounds of ice.

To turn the ice maker on and off

Press or slide the power button to turn the ice maker on/off. The button and LED illuminate when active.

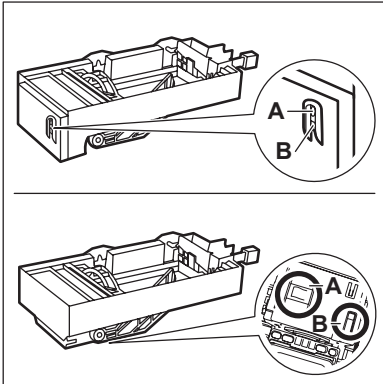

(A - power button, B - test button)

Ice maker tips

- The following sounds are normal when the ice maker is operating:
 - Motor running
 - Ice dropping into ice bin
 - Water valve opening or closing
 - Running water
- Ice cubes stored too long may develop an odd flavor. Empty the ice bin as explained below.

NOTE

The freezer ice maker fills in the center of the ice bin. Occasionally move the ice to the borders to allow the bin to fill completely.

CAUTION

If the water supply to your refrigerator is softened, be sure the softener is properly maintained. Chemicals from a water softener can damage the ice maker.

Cleaning the ice maker

Clean the ice maker and ice bin at regular intervals, especially prior to vacation or moving.

- Turn off the ice maker.
- Remove the ice bin.
- Empty and carefully clean the ice bin with mild detergent. Do not use harsh or abrasive cleaners. Rinse with clean water.
- Allow the ice bin to dry completely before replacing it in the freezer.
- Replace the ice bin. Turn the ice maker on.

Remove and empty the ice bin if an extended power failure (one hour or longer) causes ice cubes in the ice bin to melt and refreeze together after power is restored.

Remove the ice bin and shake to loosen the cubes or clean as explained above.

CAUTION

NEVER use an ice pick or similar sharp instrument to break up the ice. This could damage the ice bin.

To loosen stuck ice, use warm water. Before replacing the ice bin, make sure it is completely dry.

IMPORTANT

When removing or replacing the ice bin, ensure you fully seat the ice bin before closing the freezer door. If you do not position the ice bin correctly the refrigerator will not dispense ice. The freezer door also may not close properly causing warm air to leak into the freezer compartment.

Shelves



CAUTION

To avoid personal injury or property damage, handle tempered glass shelves carefully. Shelves may break suddenly if nicked, scratched, or exposed to sudden temperature change. Allow the glass shelves to stabilize to room temperature before cleaning. Do not wash in dishwasher.



NOTE

Features may vary according to model.

You can easily adjust shelf positions in the fresh food compartments as needed. The shelves have mounting brackets that attach to slotted supports at the rear of each compartment.

To Change the Position of a Shelf

- 1 Remove all food from the shelf.
- 2 Lift the front edge up and pull the shelf out.
- 3 Replace by inserting the mounting bracket hooks into the desired support slots.
- 4 Lower the shelf and lock it into position.

To adjust flip shelf:

- 1 Remove food from the shelf.
- 2 Lift the right side edge of shelf up and push to the left toward the ice maker.

To adjust the slide-under shelf, push the front half shelf back toward the rear of the cabinet until the rear half shelf drops down, and then gently continue pushing the front half shelf back and under the rear half shelf.

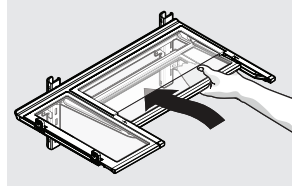

Slide-Under

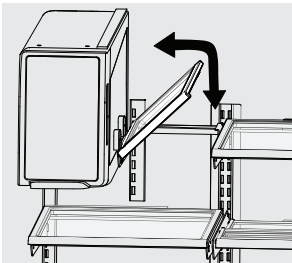

Flip Shelf

24 STORAGE FEATURES

Drawers

The refrigerator includes a variety of storage drawers.

TasteLock™ Crispers

Crispers are designed for storing fruits, vegetables, and other fresh produce. Crispers have an auto humidity control on the side of each crisper under the humidity control cover.

To remove the auto humidity control membrane for cleaning:

- 1 Reach to back of humidity control cover.
- 2 Place fingers between the humidity control and the back wall, pull up on cover.
- 3 Pull cover toward the front of cabinet and remove.
- 4 Remove the humidity membrane from the housing by lifting it up and sliding it over.
- 5 Clean the humidity membrane with hot soapy water.
- 6 Replace the membrane in the housing and replace it in the unit by reversing the steps above.

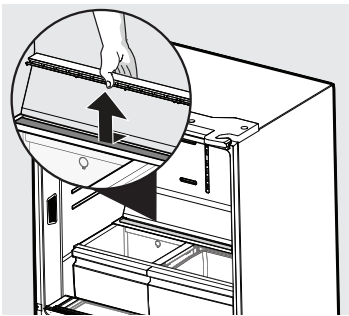

Removing Auto Humidity Control Membrane

To remove the TasteLock™ Crisper for cleaning:

- 1 Pull the drawer out until it stops.
- 2 Lift the front slightly and remove the drawer.

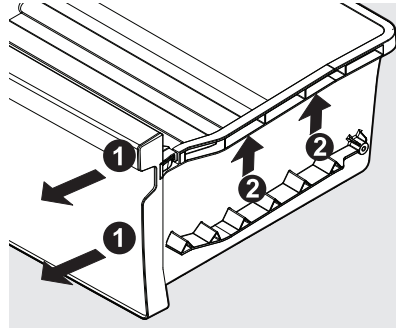

Removing TasteLock Crisper

SnackZone - Recessed Snack Drawers

These drawers are ideal for storing deli meats and cheeses.

To open: slide back the cover to allow access to the drawers.

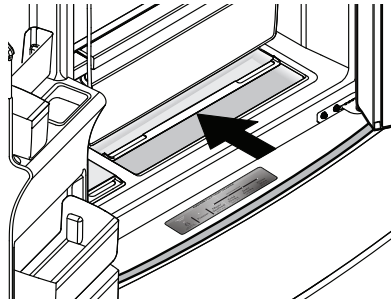

Opening SnackZone Recessed Snack Drawers

NOTE

We do not recommend replacing the auto-humidity membrane unless it becomes damaged or ruined. If the membrane becomes soiled, you wash it with soap and water. Ensure the membrane is dry before replacing it in the unit.

TEMPADAPT DRAWER



IMPORTANT

Do not use the TempAdapt Drawer to store fresh produce as these items may freeze and cause damage to the fruits and leafy vegetables stored in the drawer.

Using Your TempAdapt Drawer Controls

- 1 The drawer automatically defaults to a locked state to prevent any unwanted use. To change the drawer's settings, you first need to unlock it. To unlock, press and hold **UNLOCK** for 3 seconds. It automatically locks after 10 seconds without any interaction.



CAUTION

Do not store glass bottles in the TempAdapt Drawer when the Temperature setting is in **FREEZER**, **MEAT/SEAFOOD**, or **COLD DRINKS** modes. The glass may break and shatter, causing physical harm and injury.

Freezer:

- 2 To change the drawer temperature when in the **FREEZER** temp setting, use the control panel display on the front door. Changing the temp on the display changes both the drawer temp setting **AND** the freezer compartment.

Refrigerator:

- 3 Choosing **MEAT/SEAFOOD** sets the drawer temperature to 28°F (-2°C). A tone sounds to confirm the choice. Use this setting for short term storage. Freeze any meat to be kept longer than two days.
- 4 Choosing **COLD DRINKS** sets the drawer temperature to 32°F (0°C). A tone sounds to confirm the choice.

- 5 Choosing **DELI/SNACKS** sets the drawer temperature to 37°F (3°C). A tone sounds to confirm the choice.
- 6 Choosing **WHITE WINE** sets the drawer temperature to 45°F (7°C). A tone sounds to confirm the choice.

TempAdapt Drawer Dividers

To position drawer dividers, slide left or right. For easier repositioning, dividers do not lock but instead use the weight of stored items to keep the dividers in place. Dividers may shift when opening/closing the drawer when you store fewer items.

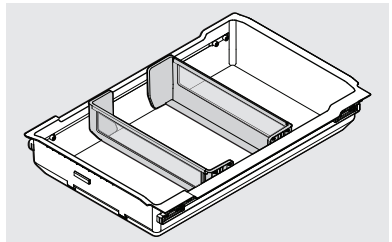

26 STORAGE FEATURES

Doors

Storage bins

The doors to the fresh food compartment use a system of modular storage bins. All of these bins are removable for easy cleaning. You can adjust the bins as needed.

Door bins are ideal for storing jars, bottles, cans, and large drink containers. They also enable quick selection of frequently used items.

Adjustable door bins

Some models have adjustable door bins you can move to suit individual needs.

To adjust the collapsible door bin:

1. Make sure the bin is securely seated on the rail in the door.
2. Grab one side of the bin and place the other hand on the adjustable side.
3. Pull on the side of the bin until you have adjusted the bin to the desired width.

NOTE

It can be difficult to pull out the collapsible bin. Some force may be required.

To move the door bin side to side:

1. Tilt the bin up so the back of the bin is off the door but the hook is still engaged.
2. Slide the bin along the rail to the desired position.
3. Lower the bin back into place.

To move door bin up or down:

1. Lift the bin up disengaging the hook.
2. Move the bin to the desired rail location.
3. Push the bin hook into the rail engaging the hook.

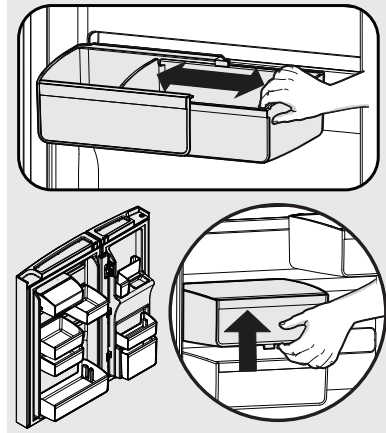

Adjustable Door Bins

Freezer Features (vary by model)

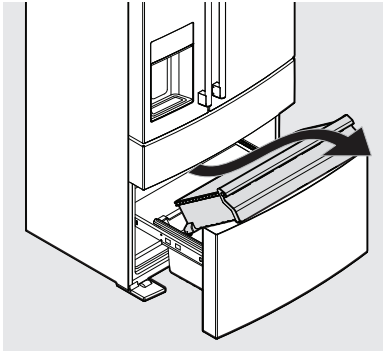

Freezer Drawer

To remove the upper freezer drawer:

- 1 Open the freezer compartment completely.
- 2 Lift up and out to remove the upper freezer drawer.

Reverse the steps to reinstall the drawer.



IMPORTANT

There are wheels on the bottom of the drawer. Make sure all wheels are aligned on their respective tracks for proper function. If the drawer is not aligned properly, it will cause problems with the door operation.



NOTE

If basket is not resting on stabilizer bar retainer clips, the drawer will not close properly.

To remove the freezer basket:

- 1 Completely open the freezer compartment
- 2 Lift the basket up and remove it.

Reverse the steps to reinstall the freezer basket.

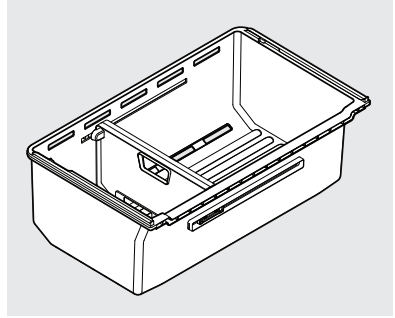

Dividers

Grab the lower divider and pull it up slightly to slide it to next the position. (You cannot remove the divider.)

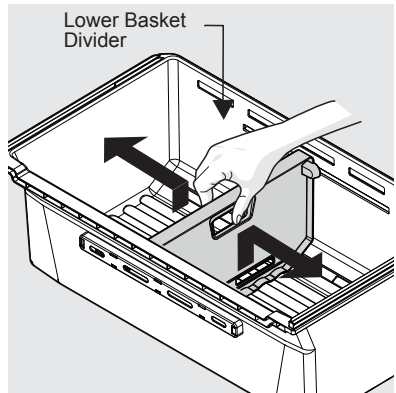

Plastic Lower Basket Divider

Ideas for storing foods

Fresh food storage

- Keep the fresh food compartment between 37° F and 40° F with an optimum temperature of 37° F.
- Avoid overcrowding the refrigerator shelves, which reduces air circulation and causes uneven cooling.
- Avoid placing food in front of air ports. (See **CONTROLS AND SETTINGS** for illustration.)

Fruits and vegetables

- Store fruits and vegetables in crispers, where trapped moisture helps preserve food quality for longer time periods.
- Wash items and remove excess water.
- Wrap any items with strong odors or high moisture content.

Meat

- Wrap raw meat and poultry separately and securely to prevent leaks and contamination of other foods or surfaces.
- Use the TempAdapt drawer and set to meat/poultry setting for short-term storage. Freeze any meat to be kept longer than two days.

Frozen food storage

- Keep the freezer compartment at 0° F or lower.
- A freezer operates most efficiently when it is at least $\frac{2}{3}$ full.

Packaging foods for freezing

- To minimize food dehydration and quality deterioration, use aluminum foil, freezer wrap, freezer bags, or airtight containers. Force as much air out of the packages as possible and seal them tightly. Trapped air can cause food to dry out, change color, and develop an off-flavor (freezer burn).
- Wrap fresh meats and poultry with suitable freezer wrap prior to freezing.
- Do not refreeze completely thawed meat.

Loading the freezer

- Prior to grocery shopping, activate **FREEZE BOOST** so that on your return you can ensure your newly purchased food designated for the freezer will be preserved as quickly as possible.

- Activating **FREEZE BOOST** also helps your freezer more efficiently maintain the selected temperature after placing new purchases with pre-existing frozen foods.
- Avoid adding too much warm food to the freezer at one time. This overloads the freezer, slows the rate of freezing, and can raise the temperature of frozen foods.
- Leave a space between packages, so cold air can circulate freely, allowing food to freeze as quickly as possible.

Ideas for saving energy

Installation

- Locate the refrigerator in the coolest part of the room, out of direct sunlight, and away from heating ducts or registers.
- Do not place the refrigerator next to heat-producing appliances such as a range, oven, or dishwasher. If this is not possible, a section of cabinetry or an added layer of insulation between the two appliances helps the refrigerator operate more efficiently.
- Level the refrigerator so the doors close tightly.

Temperature settings

- Refer to **CONTROLS AND SETTINGS** for procedures on temperature settings.

Food storage

- Avoid overcrowding the refrigerator or blocking cold air vents. Doing so causes the refrigerator to run longer using more energy and freezing food.
- Cover foods and wipe containers dry before placing them in the refrigerator. This cuts down on moisture build-up inside the unit.
- Organize the refrigerator to reduce door openings. Remove as many items as needed at one time and close the door as soon as possible.
- Do not place a hot container directly on a cold shelf. Remember, such an extreme temperature change may damage the glass.

Understanding the sounds you may hear

Your new, high-efficiency refrigerator may introduce unfamiliar sounds. These sounds normally indicate your refrigerator is operating correctly. Some surfaces on floors, walls, and kitchen cabinets may make these sounds more noticeable.

The following is a list of major components in your refrigerator and the sounds they can cause:

- A Evaporator** Refrigerant through the evaporator may create a boiling or gurgling sound.
- B Evaporator fan** You may hear air being forced through the refrigerator by the evaporator fan.
- C Defrost heater** During defrost cycles, water dripping onto the defrost heater may cause a hissing or sizzling sound. After defrosting, a popping sound may occur.
- D Automatic ice maker** When ice has been produced, you will hear ice cubes falling into the ice bin. Ice maker fan, water valve activation, and refrigerant gas fluid may create sounds from its operation.
- E Electronic control & automatic defrost control** These parts can produce a snapping or clicking sound when turning the cooling system on and off.
- F Condenser fan** You may hear air being forced through the condenser.
- G Compressor** Modern, high-efficiency compressors run much faster than older models. The compressor may have a high-pitched hum or pulsating sound.
- H Water valve** Makes a buzzing sound each time it opens to fill the ice maker.
- I Drain pan** (not removable) You may hear water dripping into the drain pan during the defrost cycle.
- J Condenser** May create minimal sounds from forced air.
- K Motorized TempAdapt drawer damper** May produce a light humming during operation.
- L Ice dispensing paddle** When dispensing ice, you will hear a snapping, clicking, or popping sound.
- M Freezer ice maker** When ice has been produced, you will hear ice cubes falling into the ice bin. Ice maker fan, water valve activation, and refrigerant gas fluid may create sounds from its operation.

NOTE

Energy efficient foam in your refrigerator is not a sound insulator.

NOTE

During automatic defrost cycle, a red glow in the back wall vents of your freezer compartment is normal.

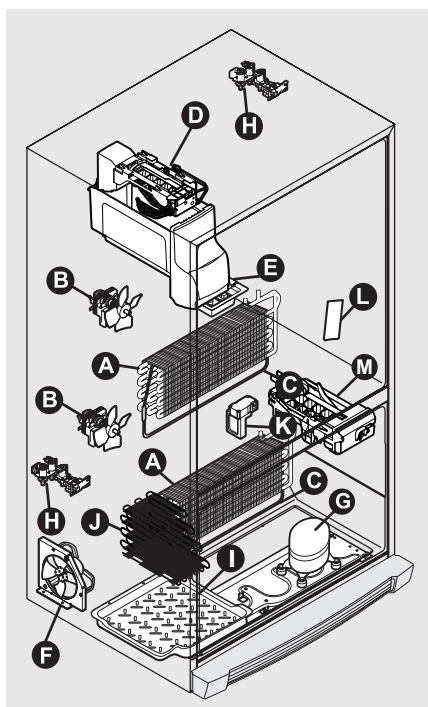

Features vary by model

30

FILTER REPLACEMENT

PureAdvantage™ Water Filter

If you have not used the refrigerator for a period of time (during moving for example), change the filter before reinstalling the refrigerator. Order replacement filters online at Electrolux.com, by calling 1-877-4ELECTROLUX (1-877-435-3287) or through the dealer from which the refrigerator was purchased. We recommend replacing filters at least once every six months.

Here is the product number to request when ordering:

PureAdvantage Water Filter, EWF02

NOTE

When ordering replacement filters, please reorder the same filter type currently in the refrigerator.

*Find the [Performance Data Sheet](#) located in the **For Owners** section for your specific water filter on Electrolux.com.

More about the Advanced Water Filter



Certified by IAPMO R&T against NSF/ANSI Standard 42, Standard 53, Standard 401, and CSA B483.1 for the reduction of substances listed below and NSF/ANSI/CAN 372 in PureAdvantage systems for reduction of the claims on the Performance Data Sheet*.

Do not use with water that is microbiologically unsafe or of unknown quality without adequate disinfection before or after the system. Systems certified for cyst reduction may be used on disinfected waters that may contain filterable cysts.

Test & certification results:

- Rated Capacity - 125 gallons/473 liters for PureAdvantage Ultra ice and water filter
- Rated service flow - .65 gallons per minute
- Operating Temp: Min. 33°F, Max. 100°F
- Maximum Rated Pressure - 100 pounds per square inch
- Recommended Minimum Operating Pressure: 30 pounds per square inch

Replacing your water filter:

The refrigerator is equipped with a water filtering system. The water filtering system filters all dispensed drinking water as well as the water used to produce ice. The water filter is located at the top right side of the fresh food compartment.

To Remove: Pull the cover forward and the cover drops down and allows access to the filter.

To Reinstall: Push the cover up toward the liner, and then push it toward the rear of the cabinet. The filter cover snaps back into place.

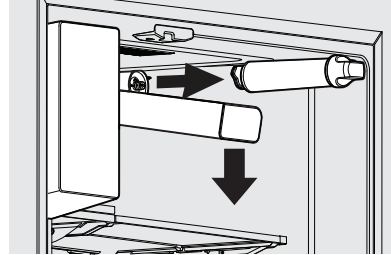

In general, you should change the water filter every six months to ensure the highest possible water quality. **Replace Water Filter** on the display indicates when to replace the filter after a standard amount of water (125 gallons/473 liters for **PureAdvantage Ultra**) has flowed through the system.

It is not necessary to turn the water supply off to change the filter. Be ready to wipe up any small amounts of water released during the filter replacement.

- 1 Turn Off the ice maker power switch.
- 2 Remove the old filter by rotating it counterclockwise (to the left) 90 degrees to release it.
- 3 Slide the old filter cartridge straight out of the housing and discard it.
- 4 Unpackage the new filter cartridge. Slide it into the filter housing as far as it will go with the grip end vertical.
- 5 Push lightly inward on the filter while rotating it clockwise (to the right). The filter will then pull itself inward as it is rotated. Rotate the filter 90 degrees until it stops and the grip end is horizontal. You may be able to feel a very light click as the filter locks into place.
- 6 Press a drinking glass against the water dispenser while checking for any leaks at the filter housing. Any spurts and sputters that occur as the system purges air out of the dispenser system are normal.
- 7 Continue dispensing water for 3-4 minutes or until 1.5 gallons of water has flowed through the system. You will likely need to empty and refill your glass several times.
- 8 Turn On the ice maker.
- 9 Press and hold the Water Filter reset button on the control panel for three seconds. When the display changes from Red to Green, the status has been reset.

PureAdvantage Ultra II™ Air Filter (select models)

Ordering your replacement air filter

To order replacement filters, please visit our online store at Electrolux.com, by calling 1-877-4ELECTROLUX (1-877-435-3287) or through the dealer where you purchased your unit. We recommend replacing filters at least once every six months.

Here is the product number to request when ordering:

PureAdvantage Air Filter, ELPALTRA2 Replacing your air filter

The air filter is located in the top center of the fresh food compartment. To ensure optimal filtering of refrigerator odors, change the air filter every six months (**Replace Air Filter** on the Display indicates replacing the filter after six months.)

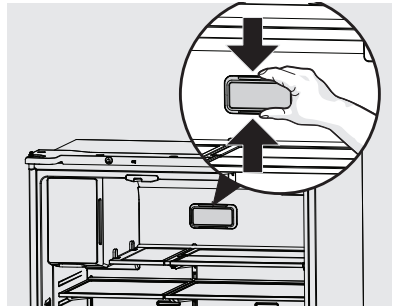

- 1 Remove the air filter cover by squeezing the top and bottom of the cover together and removing from liner.
- 2 Remove the old filter and discard it.
- 3 Unpack the new filter and snap it into the filter cover. Install the open face (carbon media) of the filter facing outward in the cover.
- 4 Replace the air filter cover by squeezing the sides and snapping it back into place.
- 5 Press and hold **AIR FILTERS** on the display for 3 seconds. The status then resets to **GOOD**.

32 CARE AND CLEANING

Protecting your investment

Keeping your refrigerator clean maintains its appearance and prevents odor buildup.

NOTE

Do not use abrasive cleaners such as window sprays, scouring cleansers, flammable fluids, cleaning waxes, concentrated detergents, bleaches, or cleansers containing petroleum products on plastic parts, interior doors, gaskets, or cabinet liners. Do not use paper towels, scouring pads, or other abrasive cleaning materials.

Immediately wipe up any spills, and clean the freezer and fresh food compartments at least twice a year.

- Never use metallic scouring pads, brushes, abrasive cleaners, or strong alkaline solutions on any surface.
- Never use CHLORIDE or cleaners with bleach to clean stainless steel.

NOTE

If you set your temperature controls to turn off cooling, power to lights and other electrical components will continue until you unplug the power cord from the wall outlet.

- Do not wash any removable parts in a dishwasher.
- Always unplug the electrical power cord from the wall outlet before cleaning.
- Remove adhesive labels by hand. Do not use razor blades or other sharp instruments which can scratch the appliance surface.
- Do not remove the serial plate. Removing your serial plate voids your warranty.
- Before moving your refrigerator, raise the anti-tip brackets so the rollers work correctly. This prevents damaging the floor.

Refer to the guide on the next page for details on caring and cleaning specific areas of your refrigerator.

CAUTION

- Pull the refrigerator straight out to move it. Shifting it from side to side may damage flooring. Be careful not to move the refrigerator beyond the plumbing connections.
- Damp objects stick to cold metal surfaces. Do not touch refrigerated surfaces with wet or damp hands.

IMPORTANT

If you store or move your refrigerator in freezing temperatures, be sure to completely drain the water supply system. Failure to do so could result in water leaks when the refrigerator is put back into service. Contact a service representative to perform this operation.

Vacation and moving tips

Occasion	Tips
Short Vacations	<ul style="list-style-type: none"> • Leave the refrigerator operating during vacations of three weeks or less. • Use all perishable items from the refrigerator compartment • Turn the automatic ice maker off and empty the ice bucket even if you will only be gone a few days.
Long Vacations	<ul style="list-style-type: none"> • Remove all food and ice if you will be gone one month or more. • Turn the cooling system off (see CONTROLS AND SETTINGS for location of On/Off button) and disconnect power cord. • Turn the water supply valve to the closed position. • Clean the interior thoroughly. • Leave both doors open to prevent odors and mold build-up. Block the doors open if necessary.
Moving	<ul style="list-style-type: none"> • Remove all food and ice. • If using a handcart, load from the side. • Adjust rollers all the way up to protect them during sliding or moving. • Pad the cabinet to avoid scratching surface.

Care and cleaning tips

Part	Cleaning Agents	Tips and Precautions
Interior & Door Liners	<ul style="list-style-type: none"> • Soap and water • Baking soda and water 	<ul style="list-style-type: none"> • Use two tablespoons of baking soda in one quart of warm water. • Be sure to wring excess water out of sponge or cloth before cleaning around controls, light bulb or any electrical part.
Door Gaskets	<ul style="list-style-type: none"> • Soap and water 	<ul style="list-style-type: none"> • Wipe gaskets with a clean soft cloth.
Drawers & Bins	<ul style="list-style-type: none"> • Soap and water 	<ul style="list-style-type: none"> • Use a soft cloth to clean drawer runners and tracks. • Do not wash any removable items (bins, drawers, etc.) in dishwasher.
Glass Shelves	<ul style="list-style-type: none"> • Soap and water • Glass cleaner • Mild liquid sprays 	<ul style="list-style-type: none"> • Allow glass to warm to room temperature before immersing in warm water.
Exterior & Handles (Stainless Steel Models Only)	<ul style="list-style-type: none"> • Soap and water • Stainless steel cleaners 	<ul style="list-style-type: none"> • Never use CHLORIDE or cleaners with bleach to clean stainless steel. • Clean stainless steel front and handles with non-abrasive soapy water and a dishcloth. Rinse with clean water and a soft cloth. • Use a non-abrasive stainless steel cleaner. These cleaners can be purchased at most home improvement or major department stores. Always follow manufacturer's instruction. Do not use household cleaners containing ammonia or bleach. • NOTE: Always clean, wipe and dry with grain to prevent scratching. • Wash the rest of the cabinet with warm water and mild liquid detergent. Rinse well and wipe dry with a clean soft cloth.

34 TROUBLESHOOTING

Let us help you troubleshoot your concern! This section will help you with common issues. If you need us, visit our website, chat with an agent, or call us. We may be able to help you avoid a service visit. If you do need service, we can get that started for you!

1-877-4ELECTROLUX (1-877-435-3287)

Electrolux.com

CONCERN	POTENTIAL CAUSE	COMMON SOLUTION
Automatic Ice Maker		
Ice maker is not making any ice.	<ul style="list-style-type: none"> • Ice maker is turned off. • Refrigerator is not connected to water line or water valve is not open. • The water supply line is kinked. • The water filter is not seated properly. • The water filter may be clogged with foreign material. • Freezer ice maker signal arm is being prevented from lowering down to check the ice level in the bin at the appropriate time. 	<ul style="list-style-type: none"> • Turn on the ice maker. Fresh Food Ice Maker - press and hold ICE MAKER on the side user interface for 3 seconds. The LED indicator illuminates to indicate the ice maker is ON. Freezer Ice Maker - press and release the power button on the front of the ice maker. The LED indicator illuminates to indicate the ice maker is ON. • Connect the unit to the household water supply and ensure the water valve is open. • Ensure the supply line does not kink when the refrigerator is pushed into place against the wall. • Remove and reinstall the water filter. Be sure to rotate it fully into the locked position. • If water dispenses slowly or not at all, or if the filter is six months old or older, replace it. • Remove any item or frozen clump of cubes preventing the signal arm from lowering down to check the ice level in the bin. Additionally, be sure the bin is properly installed.

CONCERN	POTENTIAL CAUSE	COMMON SOLUTION
Automatic Ice Maker (Cont'd)		
Ice maker is not making enough ice.	<ul style="list-style-type: none"> • Ice maker is producing less ice than you expect. • The water filter may be clogged with foreign material. • The water supply line is kinked. • Saddle valve on cold water pipe is clogged or restricted by foreign material. • Heavy traffic, opening or closing of the doors excessively. • Freezer control is set too warm (freezer ice maker). • Water pressure is extremely low. Cut-off and cut-on pressures are too low (well systems only). • Reverse osmosis system is in regenerative phase. 	<ul style="list-style-type: none"> • The ice maker produces approximately 2.0 to 2.5 pounds of ice every 24 hours depending on usage conditions. • If water dispenses slower than normal, or if the filter is six months old or older, replace it. • Ensure the supply line does not kink when you push the refrigerator into place against the wall. • Turn off the household water line valve. Remove the valve. Ensure the valve is not a self-piercing saddle valve. Clean the valve. Replace the valve if necessary. • Press FREEZE BOOST to temporarily increase ice production rate. (Freezer ice maker only.) • Set freezer control to a colder setting to improve the performance of the ice maker (freezer ice maker). Allow 24 hours for temperature to stabilize. • Have someone turn up the cut-off and cut-on pressure on the water pump system (well systems only). • It is normal for a reverse osmosis system to be below 20 psi during the regenerative phase.
Ice cubes are freezing together.	<ul style="list-style-type: none"> • Ice cubes are not being used frequently enough or interruption of power for prolonged time. • Ice cubes are hollow (shells of ice with water inside). The hollow cubes break open in the bin and leak their water onto existing ice, which causes it to freeze together. 	<ul style="list-style-type: none"> • Remove the ice bin and discard ice. The ice maker will then produce a fresh supply. Use ice at least twice weekly to keep the cubes separated. • This generally occurs when the ice maker does not get enough water. This is usually the result of a clogged water filter or restricted water supply. Replace the water filter and if the condition still occurs check for a saddle valve, water valve not turned on all the way or kinked water supply line.

36 TROUBLESHOOTING

CONCERN	POTENTIAL CAUSE	COMMON SOLUTION
Dispenser (Ice & Water)		
Dispenser will not dispense ice.	<ul style="list-style-type: none"> • There is no ice in the bin to be dispensed. • The refrigerator doors are not completely closed. • Dispenser paddle has been pressed too long and the dispenser motor has overheated. 	<ul style="list-style-type: none"> • See Ice maker is not making any ice above. • Be sure the refrigerator doors are completely closed. • The motor overload protector resets in about three minutes, and then you can dispense ice.
Ice dispenser is jammed.	<ul style="list-style-type: none"> • Ice has melted and frozen around auger due to infrequent use, temperature fluctuations, and/or power outages. • Ice cubes are jammed between the ice maker and the back of the ice bin. 	<ul style="list-style-type: none"> • Remove ice container, thaw, and empty the contents. Clean container, wipe dry, and replace in proper position. When new ice is made, dispenser should operate. • Remove ice cubes jamming the dispenser.
Dispenser will not dispense water.	<ul style="list-style-type: none"> • Water filter not seated properly. • Water filter is clogged. • Household water line valve is not open. 	<ul style="list-style-type: none"> • Remove and reinstall the water filter. For PureAdvantage Ultra, be sure to rotate it to the right until it stops and the grip end is vertical. • Replace the filter cartridge. Be sure to rotate it to the right until it stops and the grip end is vertical. • Open household water line valve. See CONCERN column Automatic Ice Maker.
Water not cold enough.	<ul style="list-style-type: none"> • All the chilled water was dispensed earlier and not enough time has passed for additional water to be properly chilled. 	<ul style="list-style-type: none"> • Add ice to a cup or container before dispensing water or allow additional time for the refrigerator to chill more water.
Water has an odd taste and/or odor.	<ul style="list-style-type: none"> • Water has not been dispensed for an extended period of time. • Unit not properly connected to cold water line. 	<ul style="list-style-type: none"> • Draw and discard 10-12 glasses of water to freshen the supply. • Connect unit to cold water line that supplies water to the kitchen faucet.

CONCERN	POTENTIAL CAUSE	COMMON SOLUTION
Opening/Closing Of Doors/Drawers		
Door(s) will not close.	<ul style="list-style-type: none"> • Door was closed too hard, causing other door to open slightly. • Refrigerator is not level. It rocks on the floor when moved slightly. • Refrigerator is touching a wall or cabinet. 	<ul style="list-style-type: none"> • Close both doors gently. • Ensure the floor is level and solid, and can adequately support the refrigerator. Contact a carpenter to correct a sagging or sloping floor. • Ensure the floor is level and solid, and can adequately support the refrigerator. Contact a carpenter to correct a sagging or sloping floor.
Drawers are difficult to move.	<ul style="list-style-type: none"> • Food is touching shelf on top of the drawer. • Track that drawers slide on is dirty. 	<ul style="list-style-type: none"> • Remove top layer of items in the drawer. • Ensure the drawer is properly installed on track. • Clean drawer, rollers, and track. See CARE AND CLEANING.
Running of Refrigerator		
Compressor does not run.	<ul style="list-style-type: none"> • Freezer control is set to "OF". • Refrigerator is in defrost cycle. • Plug at the electrical outlet is disconnected. • House fuse is blown or the circuit breaker is tripped. • Power outage. 	<ul style="list-style-type: none"> • Set freezer control. • This is normal for a fully automatic defrost refrigerator. The defrost cycle occurs periodically, lasting about 30 minutes. • Ensure the plug is tightly pushed into the outlet. • Check/replace the fuse with a 15-amp time-delay fuse. Reset circuit breaker. • Check house lights. Call local electric company.
Refrigerator seems to run too much or too long.	<ul style="list-style-type: none"> • Your variable speed compressor is designed to run 100% of the time except during the defrost cycle. At times it runs faster, such as after a defrost cycle. 	<ul style="list-style-type: none"> • It is normal for the compressor to run continuously except during defrost mode.
Digital Temperature Setting Display		
Digital temperature displays an error.	<ul style="list-style-type: none"> • Electronic control system has detected a performance problem. 	<ul style="list-style-type: none"> • Call your Electrolux service representative at 1-877-435-3287, who can interpret any messages or number codes flashing on the digital displays.

38 TROUBLESHOOTING

CONCERN	POTENTIAL CAUSE	COMMON SOLUTION
Water/Moisture/Frost Inside Refrigerator		
Moisture collects on inside of refrigerator walls.	<ul style="list-style-type: none"> • Weather is hot and humid. • Flipper mullion 	<ul style="list-style-type: none"> • The rate of frost buildup and internal sweating increases. • Adjust flipper mullion. (See To adjust the flipper mullion in INSTALLATION.)
Water collects on bottom side of drawer cover.	<ul style="list-style-type: none"> • Vegetables contain and give off moisture. 	<ul style="list-style-type: none"> • It is not unusual to have moisture on the bottom side of the cover. • Move humidity control (some models) to lower setting.
Water collects in bottom of drawer.	<ul style="list-style-type: none"> • Washed vegetables and fruit drain while in the drawer. 	<ul style="list-style-type: none"> • Dry items before putting them in the drawer. Water collecting in bottom of drawer is normal.
Water/Moisture/Frost Outside Refrigerator		
Moisture collects on outside of refrigerator or between doors.	<ul style="list-style-type: none"> • Weather is humid. 	<ul style="list-style-type: none"> • This is normal in humid weather. When humidity is lower, the moisture should disappear.
Food in Fresh Food Compartment		
Food is freezing.	<ul style="list-style-type: none"> • Temperature setting is too low. • Temperature sensor is covered by food (right side of fresh food area). • Food is covering the air ports. 	<ul style="list-style-type: none"> • Move the setting to a higher degree. • Allow space for air flow to the sensor. • Allow space between the air ports and the food.

Major Appliance Warranty Information

Your appliance is covered by a one year limited warranty. For one year from your date of delivery, Electrolux will repair or replace any parts of this appliance that prove to be defective in materials or workmanship when such appliance is installed, used, and maintained in accordance with the provided instructions. In addition, the cabinet liner and sealed refrigeration system (compressor, condenser, evaporator, dryer or tubing) of your appliance is covered by a two through five year limited warranty. During the 2nd through 5th years from your original date of purchase, Electrolux will repair or replace any parts in the cabinet liner and sealed refrigeration system which prove to be defective in materials or workmanship when such appliance is installed, used, and maintained in accordance with the provided instructions.

Exclusions

This warranty does not cover the following:

1. Products with original serial numbers that have been removed, altered or cannot be readily determined.
2. Product that has been transferred from its original owner to another party or removed outside the USA or Canada.
3. Rust on the interior or exterior of the unit
4. Products purchased "as-is" are not covered by this warranty.
5. Food loss due to any refrigerator or freezer failures.
6. Products used in a commercial setting.
7. Service calls which do not involve malfunction or defects in materials or workmanship, or for appliances not in ordinary household use or used other than in accordance with the provided instructions.
8. Service calls to correct the installation of your appliance or to instruct you how to use your appliance.
9. Expenses for making the appliance accessible for servicing, such as removal of trim, cupboards, shelves, etc., which are not a part of the appliance when it is shipped from the factory.
10. Service calls to repair or replace appliance light bulbs, air filters, water filters, other consumables, or knobs, handles, or other cosmetic parts.
11. Pickup and delivery costs; your appliance is designed to be repaired in the home.
12. Surcharges including, but not limited to, any after hour, weekend, or holiday service calls, tolls, ferry trip charges, or mileage expense for service calls to remote areas, including the state of Alaska.
13. Damages to the finish of appliance or home incurred during transportation or installation, including but not limited to floors, cabinets, walls, etc.
14. Damages caused by: services performed by unauthorized service companies; use of parts other than genuine Electrolux parts or parts obtained from persons other than authorized service companies; or external causes such as abuse, misuse, inadequate power supply, accidents, fires, or acts of God.

DISCLAIMER OF IMPLIED WARRANTIES; LIMITATION OF REMEDIES

CUSTOMER'S SOLE AND EXCLUSIVE REMEDY UNDER THIS LIMITED WARRANTY SHALL BE REPAIR OR REPLACEMENT AS PROVIDED HEREIN. CLAIMS BASED ON IMPLIED WARRANTIES, INCLUDING WARRANTIES OF MERCHANTABILITY OR FITNESS FOR A PARTICULAR PURPOSE, ARE LIMITED TO ONE YEAR OR THE SHORTEST PERIOD ALLOWED BY LAW, BUT NOT LESS THAN ONE YEAR. ELECTROLUX SHALL NOT BE LIABLE FOR CONSEQUENTIAL OR INCIDENTAL DAMAGES SUCH AS PROPERTY DAMAGE AND INCIDENTAL EXPENSES RESULTING FROM ANY BREACH OF THIS WRITTEN LIMITED WARRANTY OR ANY IMPLIED WARRANTY. SOME STATES AND PROVINCES DO NOT ALLOW THE EXCLUSION OR LIMITATION OF INCIDENTAL OR CONSEQUENTIAL DAMAGES, OR LIMITATIONS ON THE DURATION OF IMPLIED WARRANTIES, SO THESE LIMITATIONS OR EXCLUSIONS MAY NOT APPLY TO YOU. THIS WRITTEN WARRANTY GIVES YOU SPECIFIC LEGAL RIGHTS. YOU MAY ALSO HAVE OTHER RIGHTS THAT VARY FROM STATE TO STATE.

If You Need Service

Keep your receipt, delivery slip, or some other appropriate payment record to establish the warranty period should service be required. If service is performed, it is in your best interest to obtain and keep all receipts. Service under this warranty must be obtained by contacting Electrolux at the addresses or phone numbers below.

This warranty only applies in the USA, Puerto Rico and Canada. In the USA and Puerto Rico, your appliance is warranted by Electrolux Major Appliances North America, a division of Electrolux Home Products, Inc. In Canada, your appliance is warranted by Electrolux Canada Corp. Electrolux authorizes no person to change or add to any obligations under this warranty. Obligations for service and parts under this warranty must be performed by Electrolux or an authorized service company. Product features or specifications as described or illustrated are subject to change without notice.

USA
1-877-435-3287
Electrolux Major Appliances North America
10200 David Taylor Drive
Charlotte, NC 28262

Canada
1-800-265-8352
Electrolux Canada Corp.
5855 Terry Fox Way
Mississauga, Ontario,
Canada L5V 3E4

CE

A16504705 (July 2025)