



### Description

The GL-EXP-DIM-CN, GL-EXP-DIMFDB-CN, GL-EXP-DIMFLV-CN, GL-EXP-DIMU-CN, and GL-EXP-SW-CN are single-channel Crestron Green Light expansion modules that are controlled with Cresnet communication. They provide control for a variety of lighting loads. A single module supports 100 to 277 volt loads up to 16 amps.

The Crestron® GL-EXP-DIM-CN, GL-EXP-DIMFDB-CN, GL-EXP-DIMFLV-CN, GL-EXP-DIMU-CN, and GL-EXP-SW-CN share common features and functions and will be referred to as "GL-EXP-\* -CN" except where noted.

The specifications for the GL-EXP-\* -CN are listed below.

#### Specifications

SPECIFICATION	DETAILS
Load Ratings	1
Channels	16 A
Load Rating	GL-EXP-DIM-CN: LED, incandescent, neon/cold cathode, magnetic low-voltage, 2-wire dimmable fluorescent
Dimmed Load Types	GL-EXP-DIMU-CN: Incandescent, LED, electronic low-voltage, magnetic low-voltage, neon/cold cathode, 2-wire fluorescent
	GL-EXP-DIMFDB-CN: 3-wire electronic fluorescent dimming ballasts
	GL-EXP-DIMFLV-CN: LED, incandescent, fluorescent, magnetic low-voltage, electronic low-voltage, neon/cold cathode, high-intensity discharge (HID), motor
Switched Load Types	GL-EXP-SW-CN: LED, incandescent, fluorescent, magnetic low-voltage, electronic low-voltage, neon/cold cathode, high-intensity discharge (HID), motor
Input Voltage	100 to 277 Vac, 50/60 Hz
Environmental	
Temperature	32° to 104 °F (0° to 40 °C)
Humidity	10% to 90% RH (noncondensing)
Weight	3.4 lb (1.6 kg)

The dimensions for the GL-EXP-\* -CN are shown in the following illustrations.

GL-EXP-\* -CN Dimensions

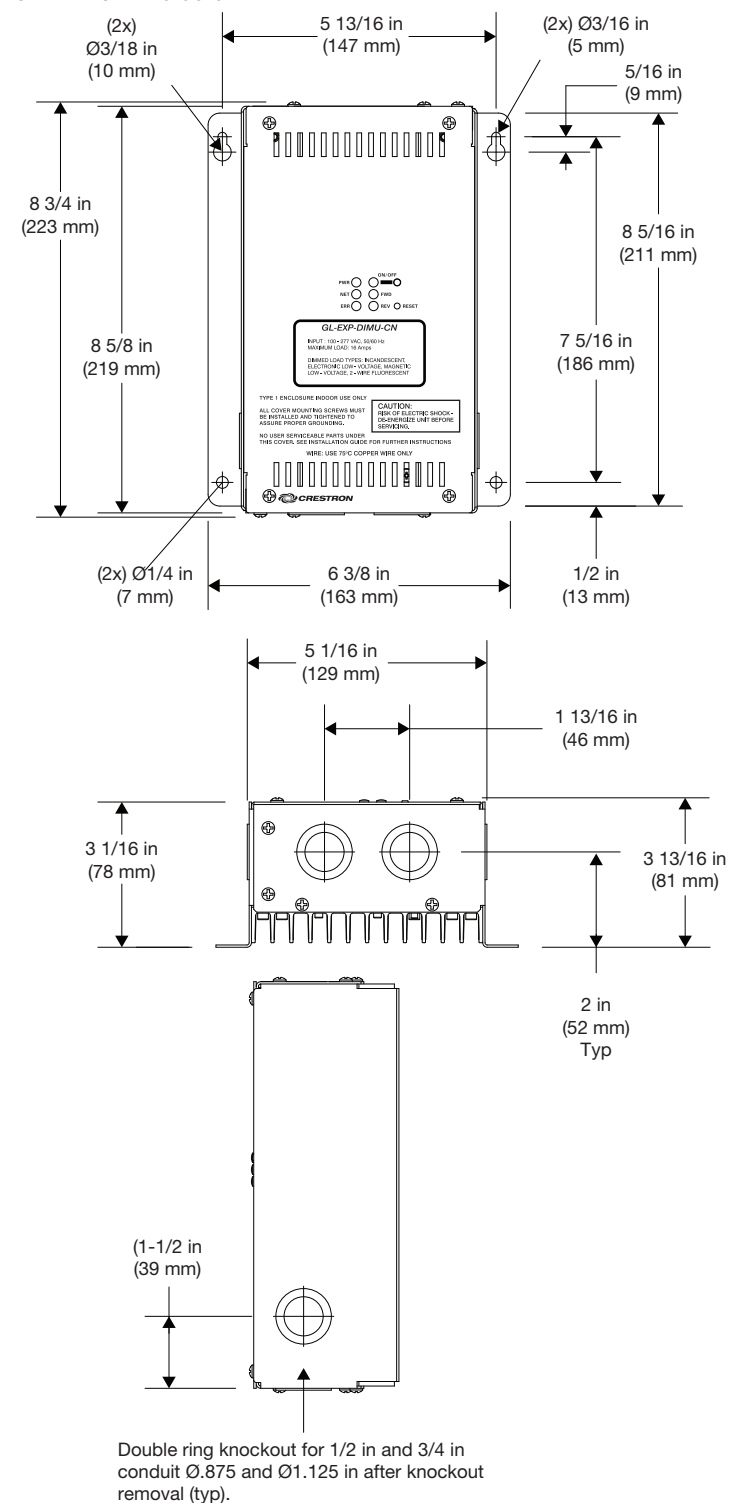

### Additional Resources

Visit the product page on the Crestron website ([www.crestron.com](http://www.crestron.com)) for additional information and the latest firmware updates. Use a QR reader application on your mobile device to scan the QR image.



### IMPORTANT SAFEGUARDS

When using electrical equipment, basic safety precautions should always be followed including the following:

READ AND FOLLOW ALL SAFETY INSTRUCTIONS.

- Do not use outdoors.
- Do not mount near gas or electric heaters.
- Equipment should be mounted in locations and at heights where it will not be subjected to tampering by unauthorized personnel.
- The use of accessory equipment not recommended by the manufacturer may cause an unsafe condition.
- Do not use this equipment for other than its intended use.
- All servicing should be performed by qualified service personnel.
- If any Emergency Circuits are fed or controlled from this panel, it must be located electrically where fed from a UPS, generator, or other guaranteed source of power during emergency and power outage situations.

SAVE THESE INSTRUCTIONS.

### Installation

**WARNING:** To avoid fire, shock, or death, turn off the power at the circuit breaker(s) or fuse and test that power is off before wiring!

**NOTE:** Observe the following points:

- This product must be installed and used in accordance with the appropriate electrical codes and regulations.
- This product must be installed by a licensed electrician.
- Use 75°C copper wire or better.

**NOTE:** Before using the GL-EXP-\* -CN, ensure the device is using the latest firmware. Check for the latest firmware for the GL-EXP-\* -CN at [www.crestron.com/firmware](http://www.crestron.com/firmware). Load the firmware onto the device using Crestron Toolbox™ software.

### Preparing and Connecting Cresnet, 0-10V, and Override Ports

Strip the ends of the wires approximately 7/16 in (11 mm). Use care to avoid nicking the conductors. Tighten the connector to 5 in-lb (0.5 to 0.6 N-m). The wire gauge should be 14 to 26 AWG.

### Installation

Mount the GL-EXP-\* -CN to any vertical surface using four screws. The screws must be appropriate for the mounting surface.

Installing the GL-EXP-\* -CN Module

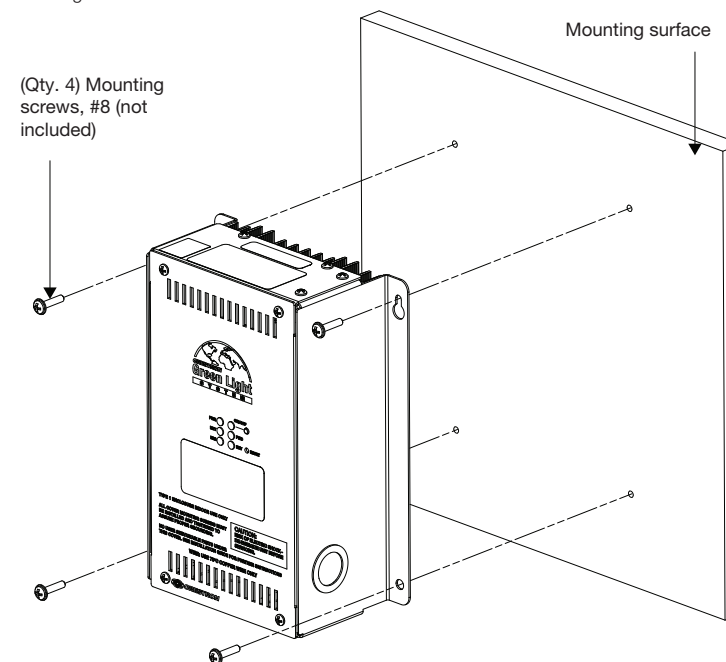

**NOTE:** To prevent potential heat damage to the drywall, do not mount the GL-EXP-\* -CN directly onto drywall. Mount the GL-EXP-\* -CN to a piece of plywood that is at least 1/2 in (13 mm) thick, and then mount the GL-EXP-\* -CN and plywood to the drywall.

**NOTE:** To ensure proper ventilation, the device must be installed vertically on a vertical surface. Install the device with 6 in (153 mm) of clearance from the top and bottom of the device.

### Wiring Diagrams

**WARNING: RISK OF SERIOUS PERSONAL INJURY.** Turn off power at the circuit breaker(s) prior to installation. Installing with power on can result in serious personal injury and damage to the device.

Wire the GL-EXP-\* -CN.

1. Use a #2 Phillips screwdriver to remove the cover screws and then remove the cover.  
Remove Cover Screws

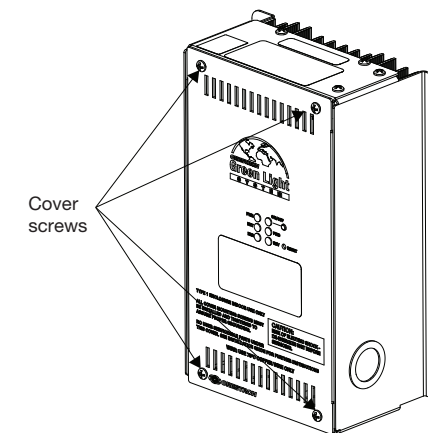

2. Wire the device as shown below. An additional LINE, NEUT, and GND connection is supplied for power to pass through. Keep the following in mind while wiring:

- Wires should be 10 to 24 AWG.
- Wires should be stripped to 5/16 in (8 mm).
- Tighten the terminal screws to 4.5 in-lbs (0.5 Nm).

Wire the GL-EXP-DIM-CN

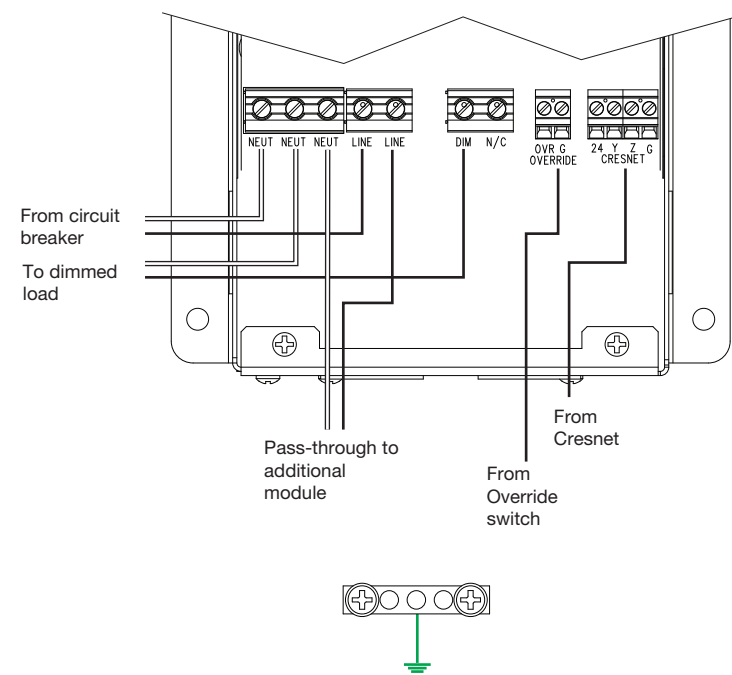

Wire the GL-EXP-DIMU-CN

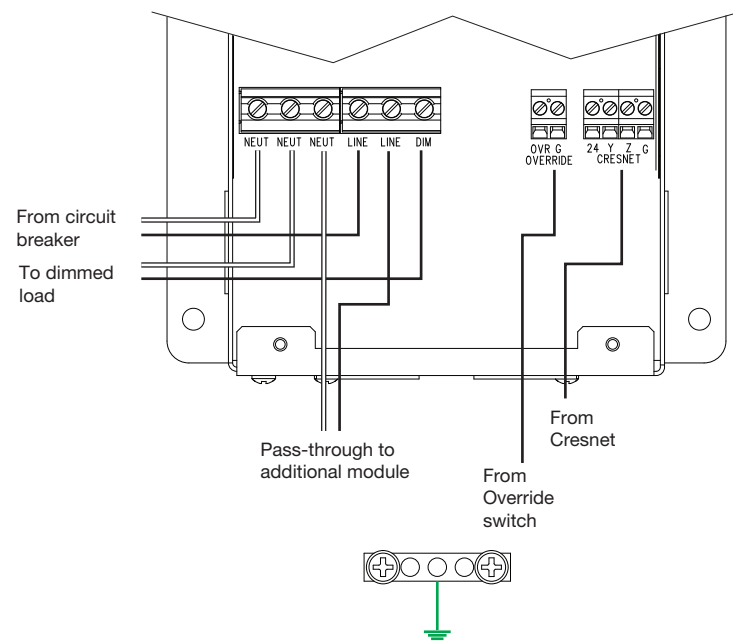

Wire the GL-EXP-DIMFLV-CN

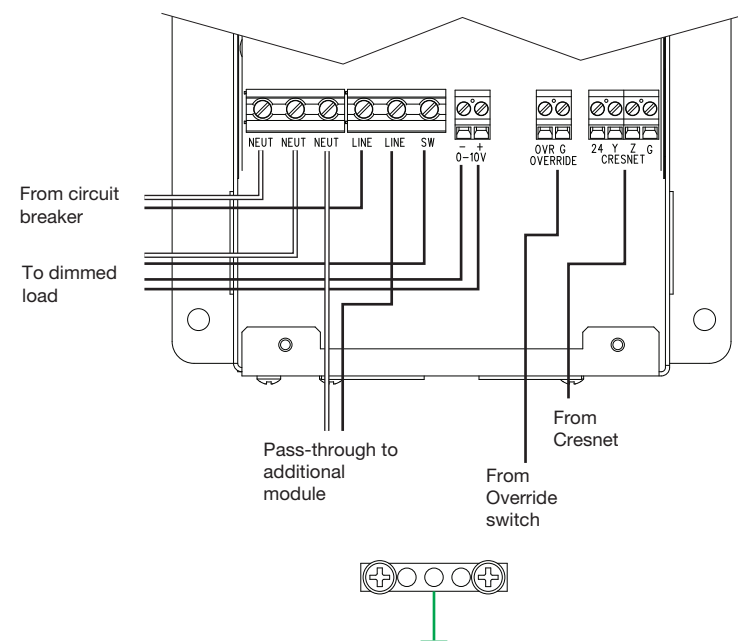

**NOTE:** When wiring the GL-EXP-DIMFLV-CN, the 0-10V control wires from the + and - terminals can be wired as Class 1 or Class 2. The unit ships with a barrier to the right of the 0-10V terminal block for Class 1 wiring. If using Class 2 wiring, move this barrier to the left of the 0-10V terminal block.

Wire the GL-EXP-SW-CN

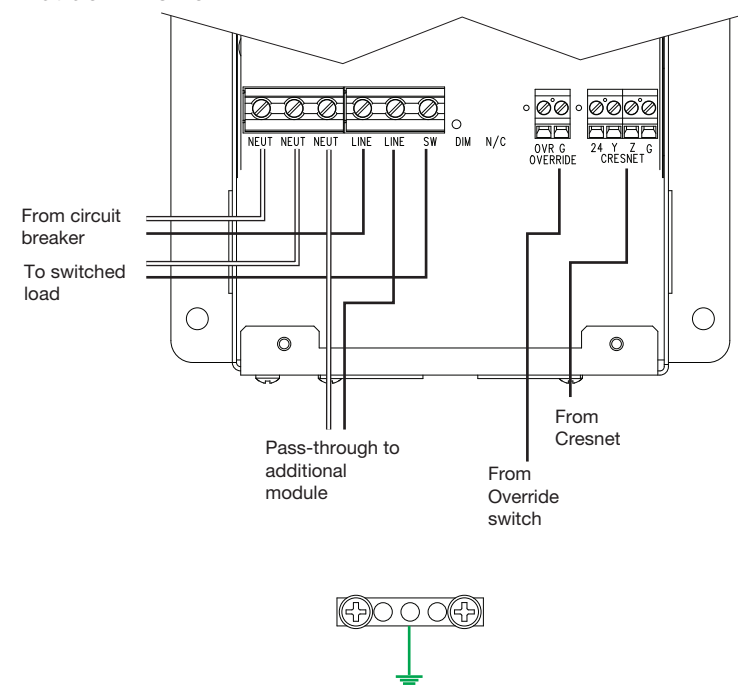

3. Replace the cover and cover screws.
4. Apply power to the module. The power indicator LED lights indicating that power is supplied to the module.

### Dimming Mode (GL-EXP-DIMU-CN Only)

The GL-EXP-DIMU-CN uses Autodetect mode to determine the attached load type and applies Forward Phase (leading edge) or Reverse Phase (trailing edge) dimming mode. Autodetect mode can be overridden to force a dimming mode. Disabling Autodetect mode should not be necessary and is not recommended unless suggested by a Crestron technical support representative.

**WARNING: RISK OF SERIOUS PERSONAL INJURY.** Turn off power at the circuit breaker(s) prior to changing any switch settings. Changing settings with the power on can result in serious personal injury and damage to the device.

**WARNING:** Incorrectly setting these switches to force the wrong mode can cause damage to the dimmer and lighting fixture.

The dimming mode can be changed by adjusting the SW3 and SW4 DIP switches as detailed below.

SW3	SW4	DIMMING MODE	LOAD TYPES
OFF	OFF	Autodetect (default, recommended)	All
ON	OFF	Forward-phase	Magnetic low-voltage, neon/cold cathode, 2-wire dimmable fluorescent
OFF	ON	Reverse phase	Incandescent, electronic low-voltage

### Zero-Cross Mode

Zero-cross mode is available for the GL-EXP-DIM-CN, GL-EXP-DIMFDB-CN, and GL-EXP-DIMU-CN only.

The GL-EXP-DIM-CN, GL-EXP-DIMFDB-CN, and GL-EXP-DIMU-CN ship with SW1 set to OFF. The dimmers should generally be left in this state. If unusual line conditions are occurring (for example, a 3-1 flash pattern described in "Error States") contact Crestron Technical Support. Crestron Technical Support may recommend setting this switch to ON for Filtered Zero-cross mode.

**WARNING: RISK OF SERIOUS PERSONAL INJURY.** Turn off power at the circuit breaker(s) prior to changing any switch settings. Changing settings with the power on can result in serious personal injury and damage to the device.

The Zero-cross mode is set using the SW1 DIP switch. Refer to the following table when setting the Zero-cross mode.

Switch Settings for the SW1 DIP Switch

SW1	DESCRIPTION
OFF	Simple Zero-cross mode.
ON	Filtered Zero-cross mode.

### Error States

The ERR LED flashes a specific pattern to indicate an error. The flash patterns are described in the table below as, for example, 1-1 or 2-1. A 1-2 flash pattern means that the LED flashes one time, pauses for one second, flashes two times, pauses for five seconds, and then repeats until the error is corrected.

LED FLASH PATTERN	ERROR STATE
1-1	The slave processor is in bootloader.
1-2	The slave processor is unresponsive.
1-3	The slave processor firmware update failed.
2-1	There is an over-current error.
2-2	A FET is shorted.
2-3	An over-temperature error exists.
2-4	An over-voltage error exists.
3-1	A zero-cross sync error exists.

Wire the GL-EXP-DIMFDB-CN

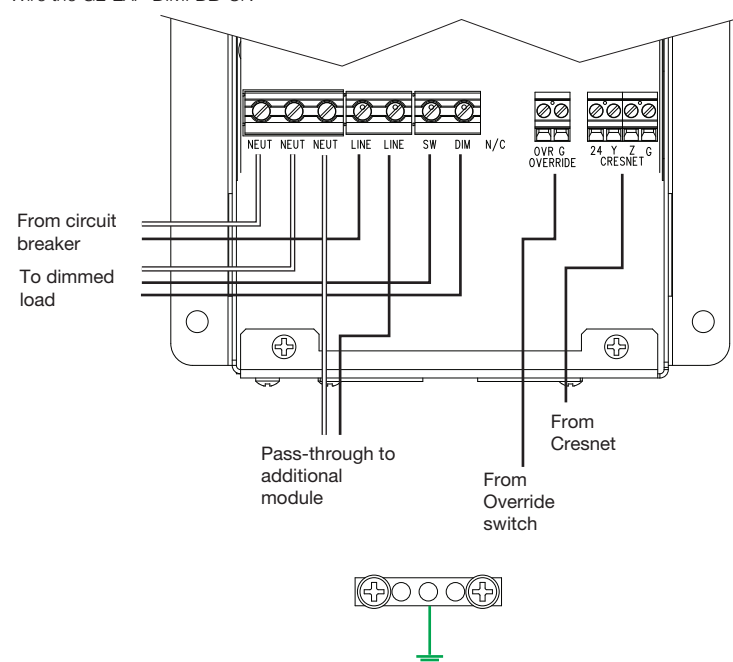

This product is Listed to applicable UL® Standards and requirements tested by Underwriters Laboratories Inc.

Ce produit est homologué selon les normes et les exigences UL applicables par Underwriters Laboratories Inc.



#### Federal Communications Commission (FCC) Compliance Statement

This device complies with part 15 of the FCC Rules. Operation is subject to the following conditions: (1) This device may not cause harmful interference and (2) this device must accept any interference received, including interference that may cause undesired operation.

**CAUTION:** Changes or modifications not expressly approved by the manufacturer responsible for compliance could void the user's authority to operate the equipment.

**NOTE:** This equipment has been tested and found to comply with the limits for a Class A digital device, pursuant to part 15 of the FCC Rules. These limits are designed to provide reasonable protection against harmful interference in a residential installation. This equipment generates, uses and can radiate radio frequency energy and, if not installed and used in accordance with the instructions, may cause harmful interference to radio communications. However, there is no guarantee that interference will not occur in a particular installation. If this equipment does cause harmful interference to radio or television reception, which can be determined by turning the equipment off and on, the user is encouraged to try to correct the interference by one or more of the following measures:

- Reorient or relocate the receiving antenna.
- Increase the separation between the equipment and receiver.
- Connect the equipment into an outlet on a circuit different from that to which the receiver is connected.
- Consult the dealer or an experienced radio/TV technician for help.

#### Industry Canada (IC) Compliance Statement

CAN ICES-3(A)/NMB-3(A)

These products have been tested by Intertek Testing Services NA Inc. and comply with ANSI/UL 2043, the Standard for Fire Test for Heat and Visible Smoke Release for Discrete Products and Their Accessories Installed in Air-Handling Spaces-Third Edition.

The product warranty can be found at [www.crestron.com/warranty](http://www.crestron.com/warranty).

The specific patents that cover Crestron products are listed at [www.crestron.com/legal/patents](http://www.crestron.com/legal/patents).

Certain Crestron products contain open source software. For specific information, please visit [www.crestron.com/opensource](http://www.crestron.com/opensource).

Crestron, the Crestron logo, Crestron Green Light, Cresnet, and Crestron Toolbox are either trademarks or registered trademarks of Crestron Electronics, Inc. in the United States and/or other countries. UL and the UL logo are either trademarks or registered trademarks of Underwriters Laboratories, Inc. in the United States and/or other countries. Other trademarks, registered trademarks, and trade names may be used in this document to refer to either the entities claiming the marks and names or their products. Crestron disclaims any proprietary interest in the marks and names of others. Crestron is not responsible for errors in typography or photography.

This document was written by the Technical Publications department at Crestron.

©2017 Crestron Electronics, Inc.

**Crestron Electronics, Inc.**  
15 Volvo Drive, Rockleigh, NJ 07647  
Tel: 888.CRESTRON  
Fax: 201.767.7576  
[www.crestron.com](http://www.crestron.com)

**Installation Guide - DOC. 7583B**

(2043187)

11.17

Specifications subject to change without notice.