

PC30IFF-IW



30" 16 Cu. Ft. Fully Integrated Bottom Freezer Refrigerator, Ice & Water, RH (I)



AVAILABLE FINISHES & COLOR OPTIONS

PC30IFF-IW
Panel Ready



FEATURES & BENEFITS

European Design Quality

Configured to suit every lifestyle and offers enough space, advanced features, and brilliant design that brings the touch of elegance to any kitchen.

30" Bottom Mount Refrigerator, 16 Cu.Ft. Total Capacity

Energy Star rated, 16 cu.ft - Spacious refrigerator and freezer capacity that can handle all of your food storage needs.

TwinCooling Plus Technology

Equipped with two separate cooling systems to cool the fresh food compartment and freezer compartment. Preventing mixture of air and odors in the refrigerator and freezer compartment.

Door-On-Door System

With the door-on-door installation, the kitchen unit and appliance doors are firmly connected with direct attachment of the unit door to the appliance door. The refrigerator door, therefore, bears the weight of the unit door.

Crisper Drawer

The proprietary crisper drawer features an adjustable temperature zone that allows fruits and vegetables to retain freshness longer.

Total No Frost

No frost ensures optimal distribution of cooling and freezing through out the refrigerator and freezer, therefore extending the freshness and longevity of stored food items.

Digital LED Control Interface

The user-friendly, LED display interface features a smooth design and easy-to-use controls, that allow for intuitive operation of the refrigerator.

LED Interior Light

Bright and efficient LED lighting highlights the contents of your refrigerator and is evenly distributed to make finding items easy.

Internal Ice & Water Dispenser

Delivers fresh, filtered water discreetly within the refrigerator and up to 4 lb. of ice per day with an automatic ice maker located in the freezer compartment.

APPEARANCE

Type	Fully Integrated (Panel Ready)
Style	Bottom Freezer
Counter Depth	Yes
Door Hinges	Right Hinge / Reversible Door
Accepts Custom Panels	Yes
Interior Color	White / Stainless Steel Rear Wall
Freezer Drawers	1 Large Drawer

CAPACITY

Refrigerator (Cu.Ft. / L)	11.5 Cu. Ft. (325L)
Freezer (Cu.Ft. / L)	4.5 Cu. Ft (127L)
Total Capacity (Cu.Ft. / L)	16 Cu. Ft. (452L)

CONTROLS

Cooling Type	Dual Evaporator / Frost-Free
Temperature Control	Electronic

FEATURES

Display Functions	Refrigerator / Freezer Temperature Compartment, Fresh Food Compartment, Holiday Mode, Sabbath Mode, Eco Mode, Child Lock
Door Open Alarm	Yes
Display Type	Digital Touch Control Display
Interior Lighting	LED (Side walls, ceiling)
No. of Compressors	1 Variable speed with inverter (VCC)
Sabbath Mode	Yes

REFRIGERATOR FEATURES

No. of Adjustable Shelves	3 Glass Shelves (1 Fixed, 2 Adjustable)
Spill Safe Shelves	Yes
No. of Humidity Controlled Crisper's	1
No. of Fresh Zone Preservation Drawers	1
No. of Door Bins	3 (2 + 1 Gallon Rack)
Fan Assisted Cooling	Yes
Water Dispenser	Yes (Internal Water Dispenser)

FREEZER FEATURES

No. of Freezer Drawers	1 Freezer Drawer (2 Compartments)
Defrost	Automatic
Quick Freeze	Yes
Ice Maker	Yes

PERFORMANCE

Annual Energy Consumption	507 kWh/year
Refrigerant	R600a
Climatic Class	ST
Noise Level dB(A)	43 dB(A)

TECHNICAL DETAILS

Electrical Supply	120 V / 15 Amp / 60 Hz
Rated Current, (A)	2.6 A
Energy Star® qualified	Yes
Power Cord Length	2540mm

DIMENSIONS

Product Dimensions (In / mm) (W / H / D)	29 ^{3/4} " / 83 ^{1/4} " / 23 ^{5/8} " (756mm / 2115mm / 600mm)
Cut-Out Dimensions (In / mm) (W / H / D)	30" / 84" / 25" - 25 ^{5/8} " (762mm / 2134mm / 635mm - 647mm)

WARRANTY

Parts & Labor	2 Years
---------------	---------

PC30IFF-IW



Installation Details

PRODUCT DIMENSIONS INCH/MM (W/H/D)

Width: 29^{3/4}" (756mm)
Height: 83^{1/4}" (2115mm)
Depth: 23^{5/8}" (600mm)

CUT-OUT DIMENSIONS INCH/MM (W/H/D)

Width: 30" (762mm)
Height: 84" (2134mm)
Depth: min. 25" (635mm)

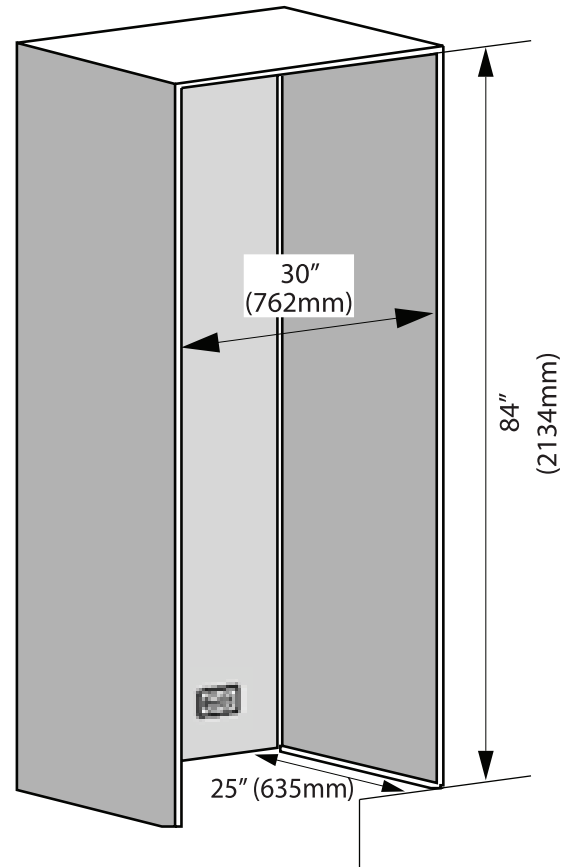
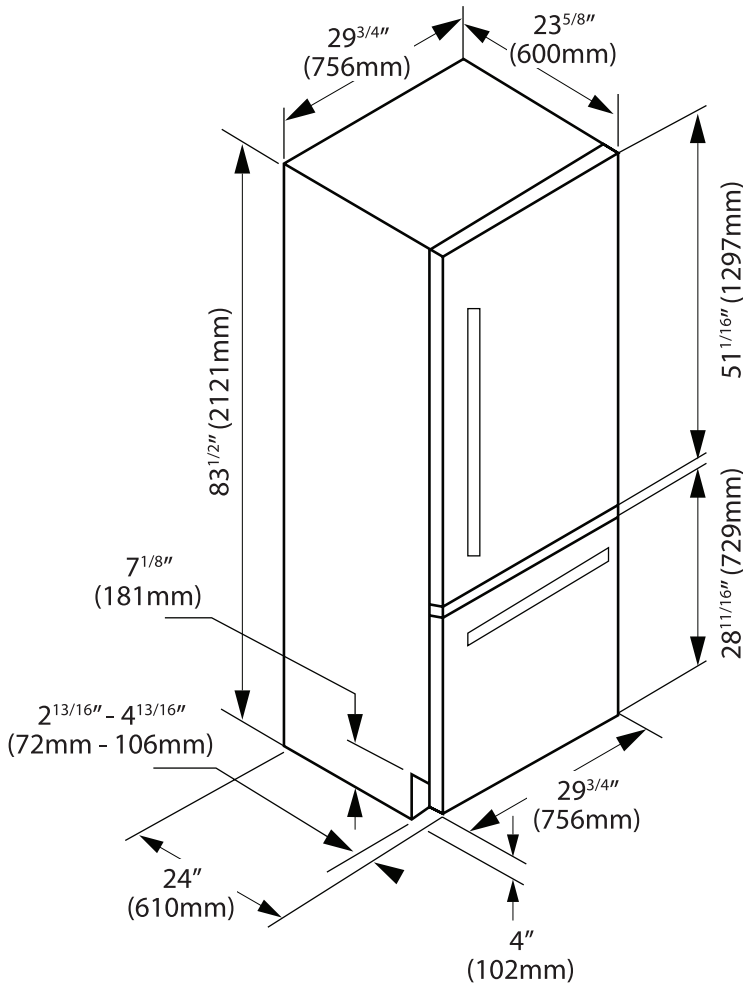

DOOR OPENING DIMENSIONS

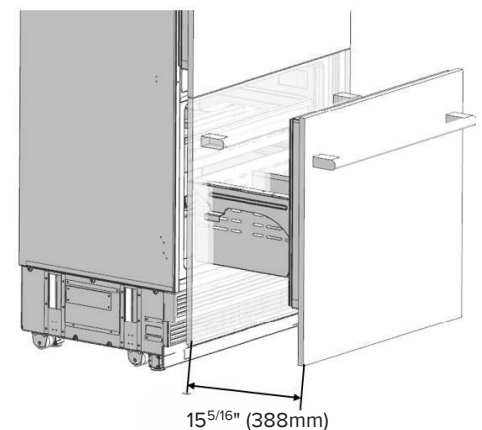
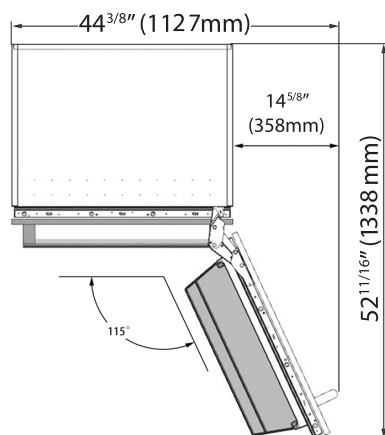
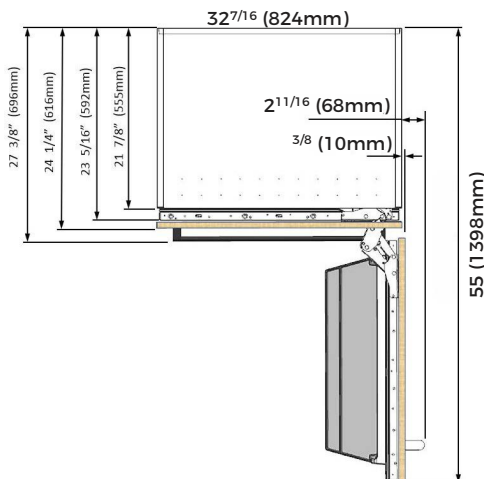

PC30IFF-IW

Installation Details

RECOMMENDED FRIDGE PANEL DIMENSIONS

Width: 29^{3/4}" (756mm)

Height: 51^{1/16}" (1297mm)

Thickness: Min. 3/4" (19mm) - Max. 1^{1/4}" (32mm)

Max. Weight: 35 lbs. (16kg)

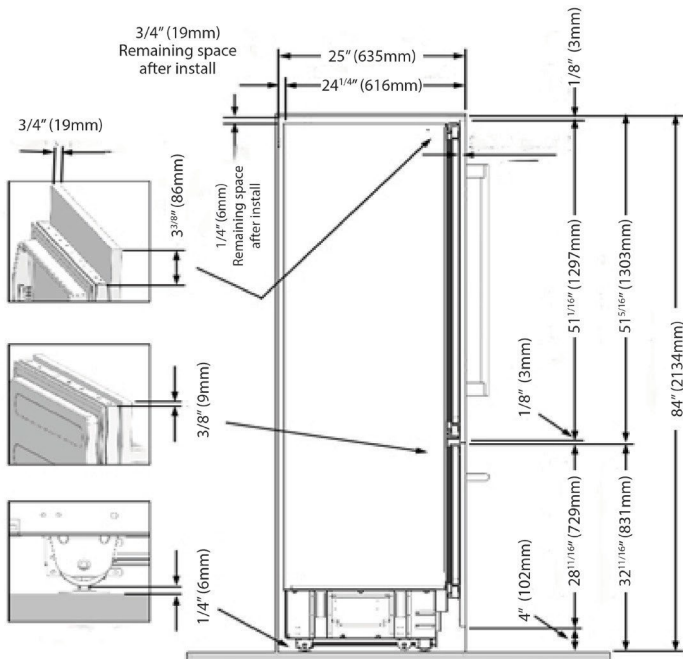
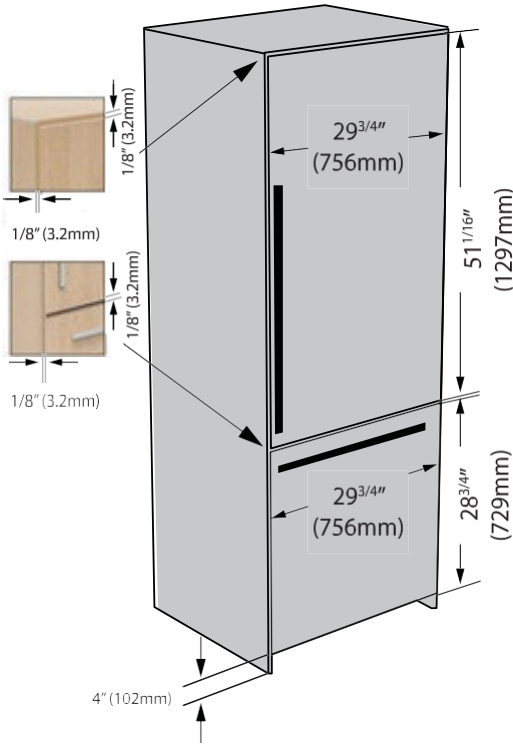

RECOMMENDED FREEZER PANEL DIMENSIONS

Width: 29^{3/4}" (756mm)

Height: 28^{11/16}" (729mm)

Thickness: Min. 3/4" (19mm) - Max. 1^{1/4}" (32mm)

Max. Weight: 19 lbs. (9kg)

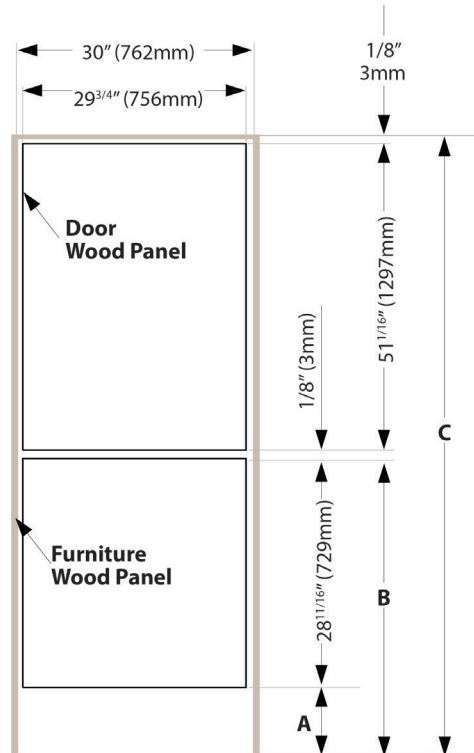

	A	B	C
Standard	4" (102mm)	32 ^{11/16} " (831mm)	84" (2134mm)
Minimum	3 ^{13/16} " (97mm)	32 ^{1/2} " (826mm)	83 ^{13/16} " (2129mm)
Maximum	5 ^{3/8} " (137mm)	34 ^{1/8} " (866mm)	85 ^{3/8} " (2169mm)

*NOTE

- Distances between the cabinet doors and the kitchen cabinet must be 1/8" (3 mm) minimum.
- Height of the Kitchen Toe kick Based on the Min./Max. Height of the Cabin.



Installation Details

*NOTE

- The power socket must be easily accessible in case of an emergency; it must not be installed behind the product.
- It is recommended to put the power socket either into an adjacent base unit, right at the back or above the refrigerator in the cabinet so that it is accessible should you need to turn the power off to the appliance.
- Both the receptacle and water tap line must be located out side of the cabinet (see installation instructions for more information.)

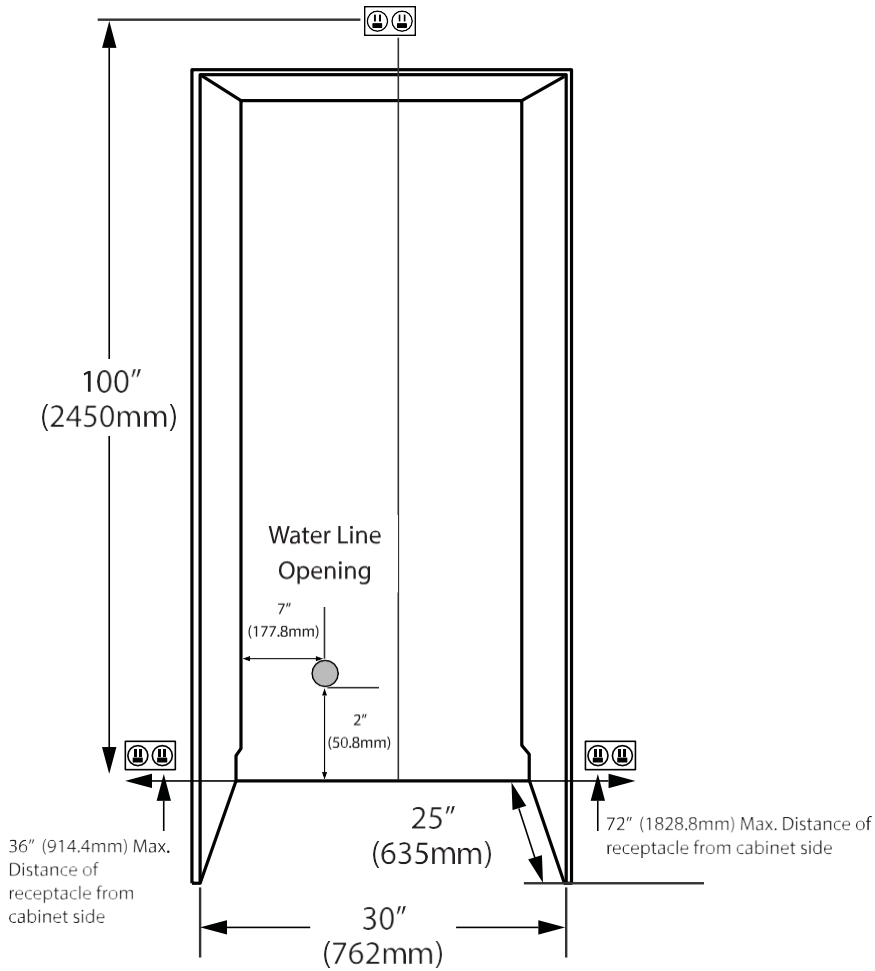

Other Product Downloads Available at
porterandcharles.ca



WARRANTY INFORMATION

Porter & Charles Appliances are designed and manufactured to the highest standards. Each appliance is covered by a comprehensive 2-year parts and labour warranty. Refer to product warranty policy for complete terms and conditions.

FOR PARTS & SERVICE

Euro-Parts & Service
39822 Belgrave Road, Belgrave, ON. N0G 1E0 1-866-722-2262
www.euro-parts.ca • parts@euro-parts.ca • service@euro-parts.ca

Porter & Charles appliances are imported and distributed in North America by Euro-Line Appliances Inc. For more information, please visit one of our showrooms or www.ela.ca

EURO-LINE APPLIANCES INC.

871 Cranberry Court, Oakville,
ON L6L 6J7 Canada
905.829.3980
1-800.421.6332
info@ela.ca

EURO-LINE APPLIANCES INC.

101-1014 Homer Street, Vancouver,
BC V6B 2W9, Canada
604.235.3980
1-855.ELA.WEST (352.9378)
infowest@ela.ca