











Assembly Instruction For

QUEEN BED

B.1090.QB

Caution: Please read instructions thoroughly before unpacking assembly parts. Sharp, exposed staple tips can cause injury, therefore, for your protection, please remove any exposed staples used in packing.

1. We recommend that you should assemble this product with the assistance of another person; this will make assembly easier, and will help to eliminate damage to the product or injury to persons during assembly.
2. Be sure to check all packing materials carefully for small parts that may have come loose inside the carton during shipment.
3. Please do not over tighten screws or bolts.
4. Please put all parts on a non-abrasive floor before assembly, and follow the assembly steps to assemble your newly purchased product correctly and efficiently.

PART LIST				HARDWARE LIST			
NO.	PART DESC	CODE	Q'TY	NO.	HARDWARE DESC	CODE	Q'TY
1	HEADBOARD	-	1	A	 JCBC SCREW (M8 x 20MM)	PB.1090. QBHW	8
2	HEADBOARD LEG (L)	PB.1090. HBLEG	1	B	 JCBC SCREW (M8 x 25MM)		8
3	HEADBOARD LEG (R)		1	C	 JCBC SCREW (M8 x 35MM)		8
4	FOOTBOARD	-	1	D	 JCBC SCREW (M6 x 35MM)		4
5	SIDE RAIL (i)	PB.1090.BE DSR1	2	E	 SPRING WASHER (M8 x 14MM)		16
6	SIDE RAIL (ii)	PB.1090.BE DSR2	2	F	 FLAT WASHER (M8 x 22MM)		16
7	SLAT	PB.1090. QBSLT	4	G	 CSK C/B SCREW (M4 x 32MM)		8
8	CENTRE SUPPORT LEG	PB.1090. BDSPL	4	H	 M4 ALLEN KEY (65MM)		1
9	SIDE RAIL SUPPORT LEG	PB.1090.BE DSRS	2	I	 M5 ALLEN KEY (65MM)		1
10	HEADBOARD LEG SUPPORT WOOD	PB.1090. QHSTR	1	J	 PLUG WITH CONNECTOR WIRE		-

STEP 1

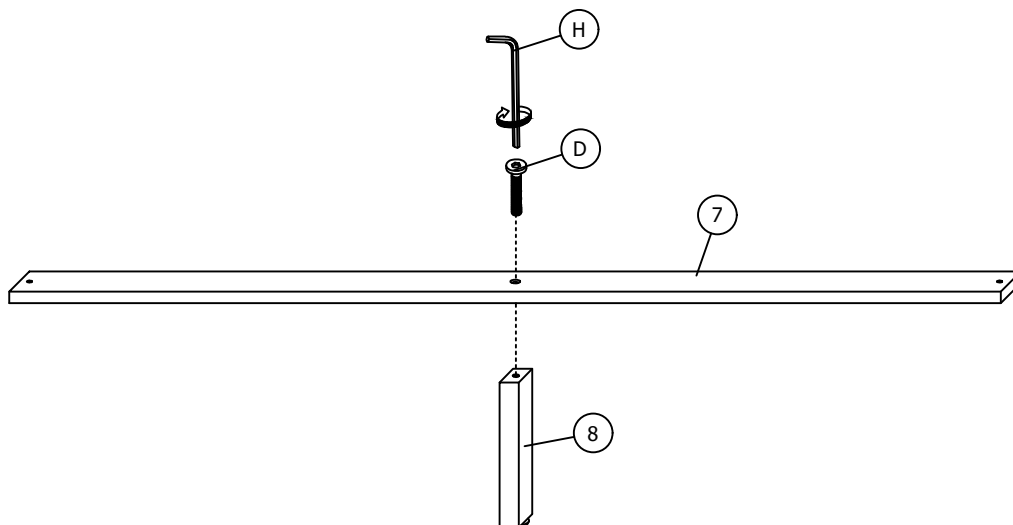

Assembly Instruction For

QUEEN BED

B.1090.QB

STEP 2

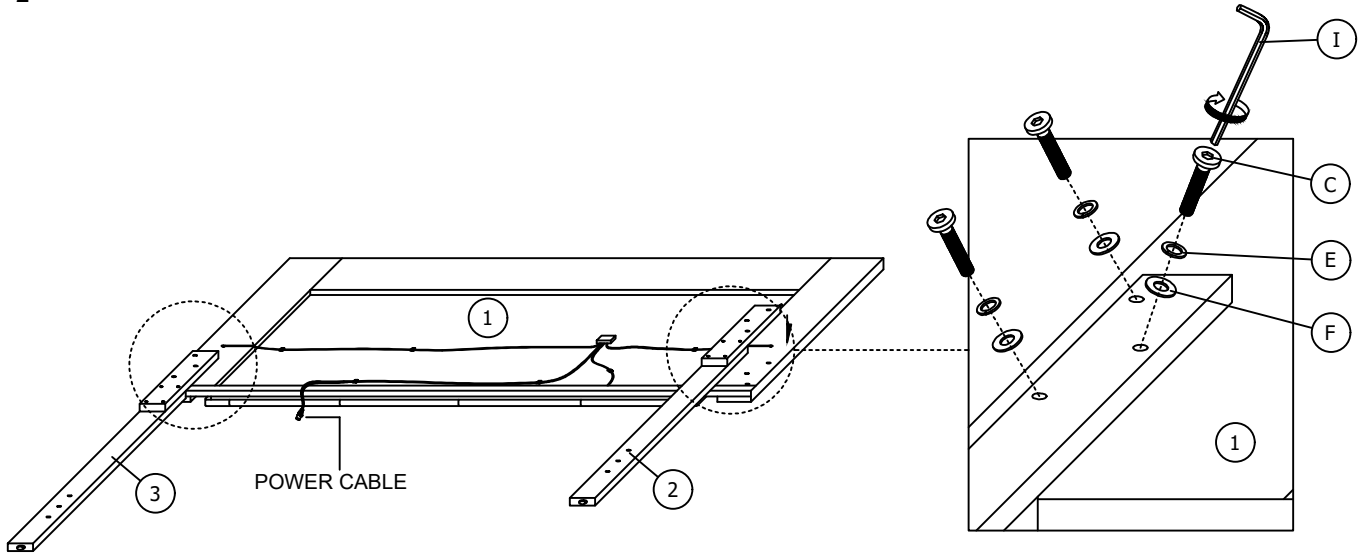

STEP 3

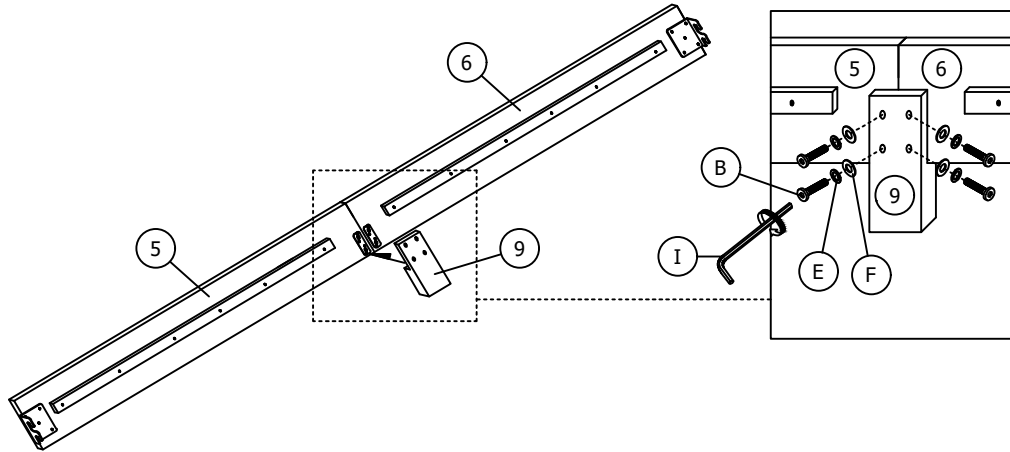

STEP 4

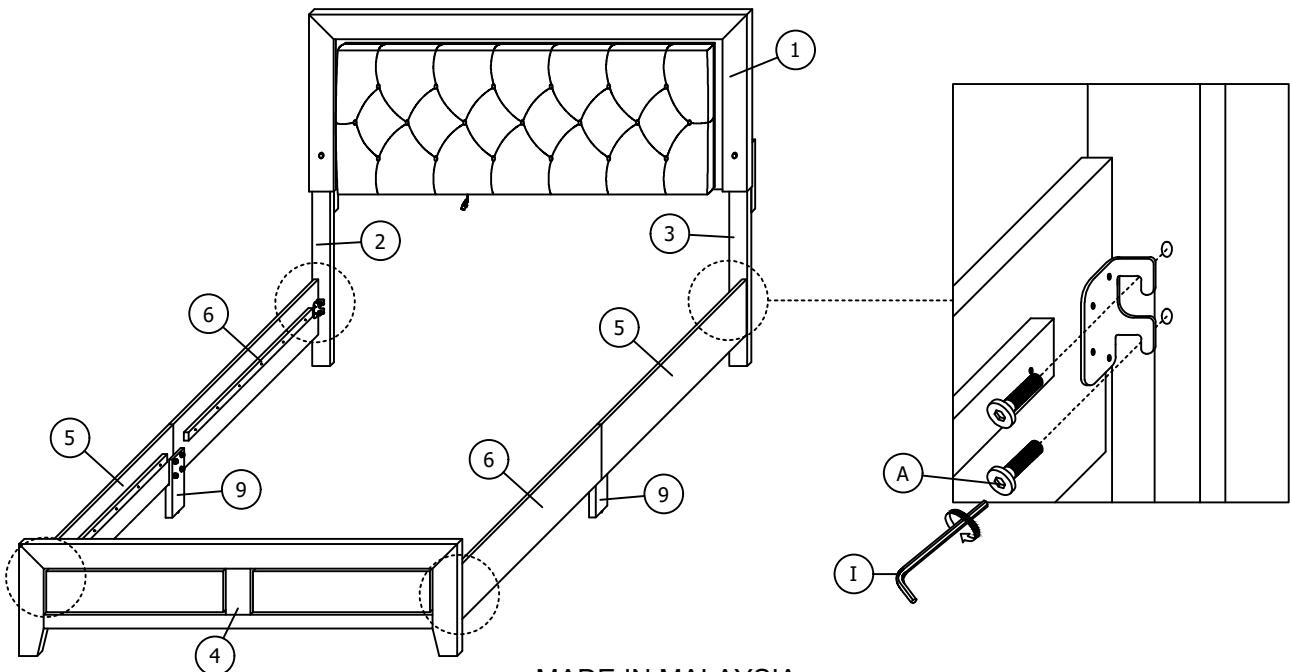

Assembly Instruction For

QUEEN BED

B.1090.QB

STEP 5
COMPLETED

HEADBOARD BACKSIDE

