

**80" Sonoma Gathering
Table**
(075)



SEASIDE CASUAL

MADE IN RHODE ISLAND



ASSEMBLY INSTRUCTIONS

1

PLEASE READ INSTRUCTIONS COMPLETELY BEFORE BEGINNING.
Carefully remove contents from box. Make sure that all parts and hardware are included using the Parts List below.

Tools Required: 4mm Allen Wrench (included); #2 Phillips Head Screwdriver;

<p>Angle Braces</p> <p>x 2</p>	<p>End Caps</p> <p>x 2</p>	<p>Table Top Assembly</p> <p>x 1</p>
<p>Leg Assemblies</p> <p>x 2</p>		<p>Stretchers</p> <p>x 1</p>
<p>1-1/4" Phillips Head Screw</p> <p>Actual Size</p> <p>Part Code: 316-8X1-1/4PFDS x 4</p>	<p>3/4" Phillips Pan Head Screw</p> <p>Actual Size</p> <p>Part Code: 316-8X3/4PPS x 6</p>	<p>4mm Allen Wrench</p> <p>Actual Size</p> <p>Part Code: 4MMALLEN x 1</p>
<p>80mm Hex Lag</p> <p>Actual Size</p> <p>Part Code: 316-1/4-10-80HL x 4</p>	<p>1-3/4" Phillips Head Screw</p> <p>Actual Size</p> <p>Part Code: 316-8X1-3/4PFDS x 8</p>	

WARRANTY QUESTIONS OR COMMENTS PLEASE CALL TOLL FREE AT 1-800-809-3114

2**ATTACH STRETCHER TO LEG ASSEMBLIES**

Attach stretcher leg assemblies using (4) 80 mm Hex Lags thru counter-bored holes in Leg Assembly into pilot holes in both sides of Stretcher.

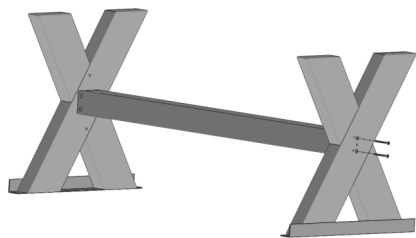
**3****ATTACH BASE TO TABLE TOP**

Align holes in leg aluminum with large holes in the long table top aluminum. Secure with (4) 1-1/4" Phillips Head Screws.

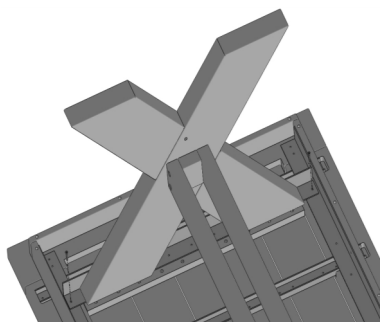
**4****ATTACH ALUMINUM TO TABLE TOP**

Secure center of leg aluminum to table top using (6) 3/4" Phillips Pan Head Screws. Hold at a slight angle to access holes in aluminum.

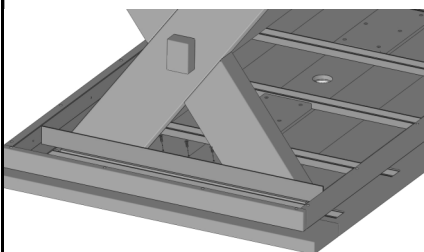
**5****ATTACH ANGLE BRACES**

Align angle braces to stretcher assembly and table top as shown. Secure using (4) 1-3/4" Phillips Head Screws.

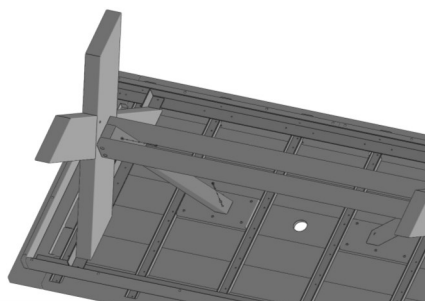
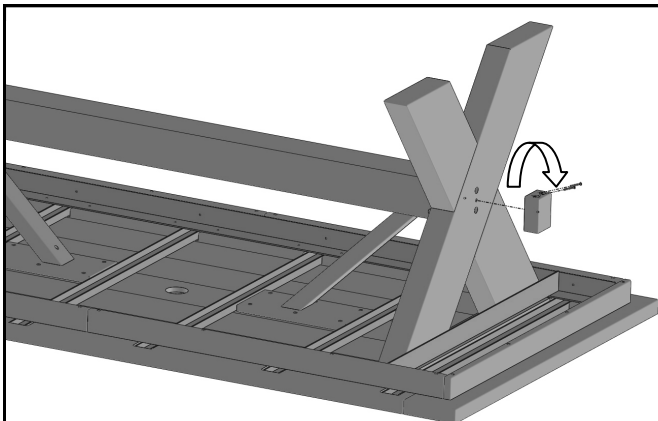
**7****SECURE END CAPS**

Insert End Caps into threaded insert in Leg Assembly. Turn clockwise until snug. Continue turning until in line with the Stretcher as shown. Secure end caps into legs with (4) 1-3/4" Phillips Head Screws.