



XOOTR24BS

MAKE-UP AIR COMPLIANT
OVER-THE-RANGE MICROWAVE

HOW BEAUTIFUL KITCHENS BREATHE...



24" OVER-THE-RANGE MICROWAVE OVEN Perfect for smaller kitchens

This elegant space saving appliance is both an efficient, fully featured microwave oven and kitchen ventilation system capable of either recirculation for installations where venting outside is not possible, or ducted operating from either the top or rear of the unit.

Small in size - big on functionality, just what you would expect from XO.

WORLD CLASS SERVICE | COMPREHENSIVE WARRANTIES

OUR LASTING COMMITMENT TO YOU

xoappliance.com | 800.966.8300



3-1/4" x 10"
TOP or REAR
VENTING

**CUT OUT
DIMENSIONS**

Height	16-1/2"
Width	24"
Depth	13"

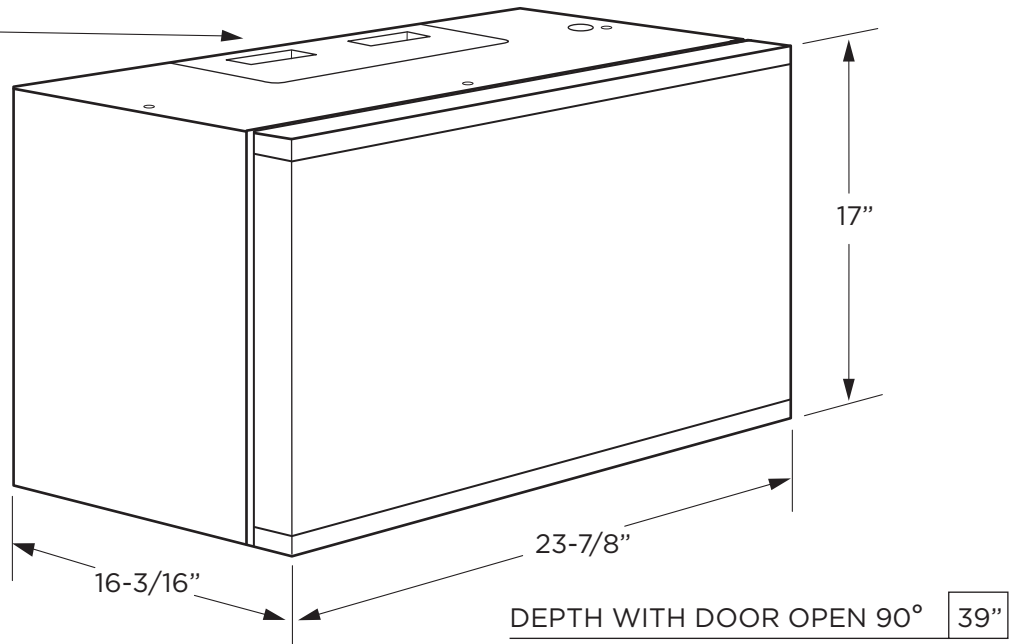

FEATURES

FINISH

- Black Glass Door w Stainless Steel Trim
- Integrated Handle
- LED Clock
- 2 Level LED Lighting Illuminates Cooking Area

MICROWAVE

- 1000W | 1.34 cu ft Microwave
- Touch Controls w 10 Power Levels
- Pre-Programmed Control Options
- Sensor Cooking and Auto-Defrost
- 13-5/8" Diameter Turntable w On/Off Feature

VENTILATION

- 2 Speed Blower 105 / 300 CFM (MUA Compliant)
- Recirculation Standard
- Top or Rear Venting Option, Included (3-1/4" x 10")
- Auto Start Heat Sensor
- Dishwasher Safe Grease Filters
- Carbon Filter for Recirculation, Included

SPECIFICATIONS

ELECTRICAL 120VAC 60HZ 13 AMP*

PWR CONNECTION RIGHT TOP REAR

OVEN INTERIOR WHITE

INTERIOR DIM. 10-11/16" x 15-3/8" x 15-5/16"

SHIPPING WGT. 59 lbs

*dedicated 15 amp service required
unit must be properly grounded
see installation instructions



REPLACEMENT
RECIRCULATION
FILTERS
P/N: XORFK014



THE NEXT LEVEL IN OUTDOOR KITCHENS

xoappliance.com | 800.966.8300

XO is exclusively distributed by
EASTERN MARKETING CORP.
24 Eisenhower Parkway
Roseland, NJ 07068