



HOSHIZAKI

Instruction Manual

Modular Flaker

Models

F-150 IMAJ(-C)(-SC)

F-150 IMWJ(-C)(-SC)

F-150 IMRJZ(-C)(-SC)

F-200 IMWJ(-C)

F-200 IMRJZ/3(-C)(-SC)

F-200 IMLJ



⚠ WARNING

Only qualified service technicians should install and service the appliance. To obtain the name and phone number of your local Hoshizaki Certified Service Representative, visit www.hoshizakiamerica.com. No installation or service should be undertaken until the technician has thoroughly read this Instruction Manual. Likewise, the owner/manager should not proceed to operate the appliance until the installer has instructed them on its proper operation. Failure to install, operate, and maintain the appliance in accordance with this manual will adversely affect safety, performance, component life, and warranty coverage and may result in costly water damage. Proper installation is the responsibility of the installer. Product failure or property damage due to improper installation is not covered under warranty.

Hoshizaki provides this manual primarily to assist qualified service technicians in the installation, maintenance, and service of the appliance.

Should the reader have any questions or concerns which have not been satisfactorily addressed, please call, send an e-mail message, or write to the Hoshizaki Technical Support Department for assistance.

Phone: 1-800-233-1940; (770) 487-2331

Fax: 1-800-843-1056; (770) 487-3360

E-mail: techsupport@hoshizaki.com

HOSHIZAKI AMERICA, INC.

618 Highway 74 South

Peachtree City, GA 30269

Attn: Hoshizaki Technical Support Department

NOTE: To expedite assistance, all correspondence/communication **MUST** include the following information:

- Model Number _____
- Serial Number _____
- Complete and detailed explanation of the problem.

IMPORTANT

This manual should be read carefully before the appliance is serviced. Read the warnings and guidelines contained in this booklet carefully as they provide essential information for the continued safe use, service, and maintenance of the appliance. Retain this booklet for any further reference that may be necessary.

CONTENTS

Important Safety Information	5
I. Specifications.....	7
A. Electrical and Refrigerant Data	7
1. F-1501M_J(Z)(-C)(-SC).....	7
2. F-2001M_J(Z)(-C)(-SC)	8
3. F-2001MRJZ3.....	8
B. Dimensions/Connections	9
1. Air-Cooled Models (F-1501MAJ(-C)(-SC))	9
2. Water-Cooled Models (MWJ(-C)(-SC))	10
3. Remote Models (MRJZ/3(-C)(-SC))	11
4. Low Side, Parallel Rack System Models (F-2001MLJ)	12
5. Remote Condenser Unit URC-14FZ (use with F-1501MRJZ(-C)(-SC))	13
6. Remote Condenser Unit URC-22FZ (use with F-2001MRJZ/3(-C)(-SC)).....	13
II. Installation and Operating Instructions	14
A. Location	14
B. Checks Before Installation	14
C. How to Remove Panels	15
D. Dispenser Unit/Ice Storage Bin and Icemaker Setup	16
E. Electrical Connection	17
F. Water Supply and Drain Connections	19
G. Remote Condenser Unit Installation	23
1. Location	23
2. Checks Before Installation	24
3. Setup.....	24
4. Line Set Size and Refrigerant Charge	25
5. Line Set Installation	26
6. Electrical Connection	28
7. Stacking Remote Condenser Unit	29
H. Parallel Rack System Connection	30
1. Line Set Size and Rack System Requirements	30
2. Line Set Installation.....	31
I. Final Checklist	33
1. Pre-Startup	33
2. Post-Startup	34
J. Startup.....	35
1. Bin Control Setting.....	35
2. Bin Control Check	38
K. Alarm Safeties	41

III. Maintenance	42
A. Maintenance Schedule	43
B. Cleaning and Sanitizing Instructions	44
IV. Preparing the Appliance for Periods of Non-Use	48
V. Disposal	50

Important Safety Information

Throughout this manual, notices appear to bring your attention to situations which could result in death, serious injury, damage to the appliance, or damage to property.

⚠️ WARNING Indicates a hazardous situation which could result in death or serious injury.

NOTICE Indicates a situation which could result in damage to the appliance or property.

IMPORTANT Indicates important information about the installation, use, and care of the appliance.

⚠️ WARNING

The appliance should be destined only to the use for which it has been expressly conceived. Any other use should be considered improper and therefore dangerous. The manufacturer cannot be held responsible for injury or damage resulting from improper, incorrect, and unreasonable use. Failure to install, operate, and maintain the appliance in accordance with this manual will adversely affect safety, performance, component life, and warranty coverage and may result in costly water damage.

To reduce the risk of death, electric shock, serious injury, or fire, follow basic precautions including the following:

- Only qualified service technicians should install and service the appliance.
- The appliance must be installed in accordance with applicable national, state, and local codes and regulations.
- Electrical connection must be hard-wired and must meet national, state, and local electrical code requirements. Failure to meet these code requirements could result in death, electric shock, serious injury, fire, or damage.
- The icemaker requires an independent power supply of proper capacity. See the nameplate for electrical specifications. Failure to use an independent power supply of proper capacity can result in a tripped breaker, blown fuse, damage to existing wiring, or component failure. This could lead to heat generation or fire.
- **THE ICEMAKER MUST BE GROUNDED.** Failure to properly ground the icemaker could result in death or serious injury.
- To reduce the risk of electric shock, do not touch the power switch or control switch with damp hands.
- Move the power switch to the "OFF" position and turn off the power supply before servicing. Lockout/Tagout to prevent the power supply from being turned back on inadvertently.
- Do not place fingers or any other objects into the ice discharge opening.
- Do not make any alterations to the appliance. Alterations could result in electric shock, injury, fire, or damage.

⚠ WARNING, continued

- The appliance is not intended for use by persons (including children) with reduced physical, sensory, or mental capabilities, or lack of experience and knowledge, unless they have been given supervision or instruction concerning use of the appliance by a person responsible for their safety.
- Children should be properly supervised around the appliance.
- Do not climb, stand, or hang on the appliance or allow children or animals to do so. Serious injury could occur or the appliance could be damaged.
- Do not use combustible spray or place volatile or flammable substances near the appliance. They might catch fire.
- Keep the area around the appliance clean. Dirt, dust, or insects in the appliance could cause harm to individuals or damage to the appliance.

Additional Warning for Remote Models

- **THE REMOTE CONDENSER UNIT MUST BE GROUNDED.** The power supply and ground connection to the remote condenser unit are supplied from the icemaker. Failure to properly ground the remote condenser unit could result in death or serious injury.
- Wire routing (conduit) and disconnect (if required) must meet national, state, and local electrical code requirements. Failure to meet these code requirements could result in death, electric shock, serious injury, fire, or damage.

NOTICE

- Follow the water supply, drain connection, and maintenance instructions carefully to reduce the risk of costly water damage.
- In areas where water damage is a concern, install in a contained area with a floor drain.
- Install the icemaker in a location that stays above freezing. Normal operating ambient temperature must be within 45°F to 100°F (7°C to 38°C).
- Do not leave the icemaker on during extended periods of non-use, extended absences, or in sub-freezing temperatures. To properly prepare the icemaker for these occasions, follow the instructions in "IV. Preparing the Appliance for Periods of Non-Use."
- Do not place objects on top of the appliance.
- The dispenser unit/ice storage bin is for ice use only. Do not store anything else in the dispenser unit/ice storage bin.

I. Specifications

A. Electrical and Refrigerant Data

The rating label and nameplate provide electrical and refrigerant data. The rating label can be seen by removing the front panel. The nameplate is located on the rear panel. For certification marks, see the nameplate.

We reserve the right to make changes in specifications and design without prior notice.

1. F-1501M_J(Z)(-C)(-SC)

Single Phase			
Model Number	F-1501MAJ(-C)(-SC)	F-1501MWJ(-C)(-SC)	F-1501MRJZ(-C)(-SC)
AC Supply Voltage	208-230/60/1 (3 wire with neutral)	208-230/60/1 (3 wire with neutral)	208-230/60/1 (3 wire with neutral)
Compressor	208-230V 9.3RLA 56LRA	208-230V 9.3RLA 56LRA	208-230V 9.3RLA 56LRA
Gear Motor	115V 5.6 FLA 400W	115V 5.6 FLA 400W	115V 5.6 FLA 400W
Fan Motor	115V 1.0 FLA 1/15HP	Cabinet: 115V 0.51 FLA 8W	Cabinet: 115V 0.51 FLA 8W
			Remote: 115V 3A MAX
Other	115V 0.03A	115V 0.03A	115V 0.03A
Maximum Fuse Size	20 AMPS	20 AMPS	20 AMPS
Max. HACR Breaker (USA Only)	20 AMPS	20 AMPS	20 AMPS
Max. Circuit Breaker (Canada Only)	20 AMPS	20 AMPS	20 AMPS
Minimum Circuit Ampacity	20 AMPS	20 AMPS	20 AMPS
Design Pressure	HI-467PSI LO-250PSI	HI-427PSI LO-250PSI	HI-467PSI LO-250PSI
Refrigerant	404A 2 LB. 5 OZ.	404A 1 LB 4.5 OZ	404A Total Refrigerant Charge with Hoshizaki Remote Condenser Unit URC-14FZ: 9 LB. 9 OZ.

2. F-2001M_J(Z)(-C)(-SC)

Single Phase			
Model Number	F-2001MWJ(-C)	F-2001MRJZ(-C)(-SC)	F-2001MLJ
AC Supply Voltage	208-230/60/1	208-230/60/1	115/60/1
Compressor	240V 10.8RLA 96LRA	240V 10.8RLA 96LRA	---
Gear Motor	120V 5.6 FLA 400W	120V 5.6 FLA 400W	120V 5.6 FLA 400W
Cabinet Fan Motor	115V 0.51 FLA 8W	115V 0.51 FLA 8W	115 0.51 FLA 8W
Remote Fan Motor	---	120V 3A MAX	
Other	120V 0.03A	120V 0.03A	120V 0.3A
Maximum Fuse Size	30 AMPS	30 AMPS	15 AMPS
Max. HACR Breaker (USA Only)	30 AMPS	30 AMPS	15 AMPS
Max. Circuit Breaker (Canada Only)	30 AMPS	30 AMPS	15 AMPS
Minimum Circuit Ampacity	30 AMPS	30 AMPS	15 AMPS
Design Pressure	HI-467PSI LO-290PSI	HI-467PSI LO-290PSI	HI-467PSI LO-290PSI
Refrigerant	404A 2 LB.	404A Total Refrigerant Charge with Hoshizaki Remote Condenser Unit URC-22FZ: 15 LB. 14 OZ	Use only with 404A, 407A, or 407F. Factory Holding Charge 15PSI Nitrogen

3. F-2001MRJZ3

Three Phase	
Model Number	F-2001MRJZ3
AC Supply Voltage	208-230-/60/3
Compressor	240V 9.0RLA 75LRA
Gear Motor	120V 5.6 FLA 400W
Cabinet Fan Motor	115V 0.51 FLA 8W
Remote Fan Motor	120V 3A MAX
Other	120V 0.03A
Maximum Fuse Size	20 AMPS
Max. HACR Breaker (USA Only)	20 AMPS
Max. Circuit Breaker (Canada Only)	20 AMPS
Minimum Circuit Ampacity	20 AMPS
Design Pressure	HI-467PSI LO-290PSI
Refrigerant	404A Total Refrigerant Charge with Hoshizaki Remote Condenser Unit URC-22FZ: 15 LB. 14 OZ.

B. Dimensions/Connections

1. Air-Cooled Models (F-1501MAJ(-C)(-SC))

Units: mm [in.]

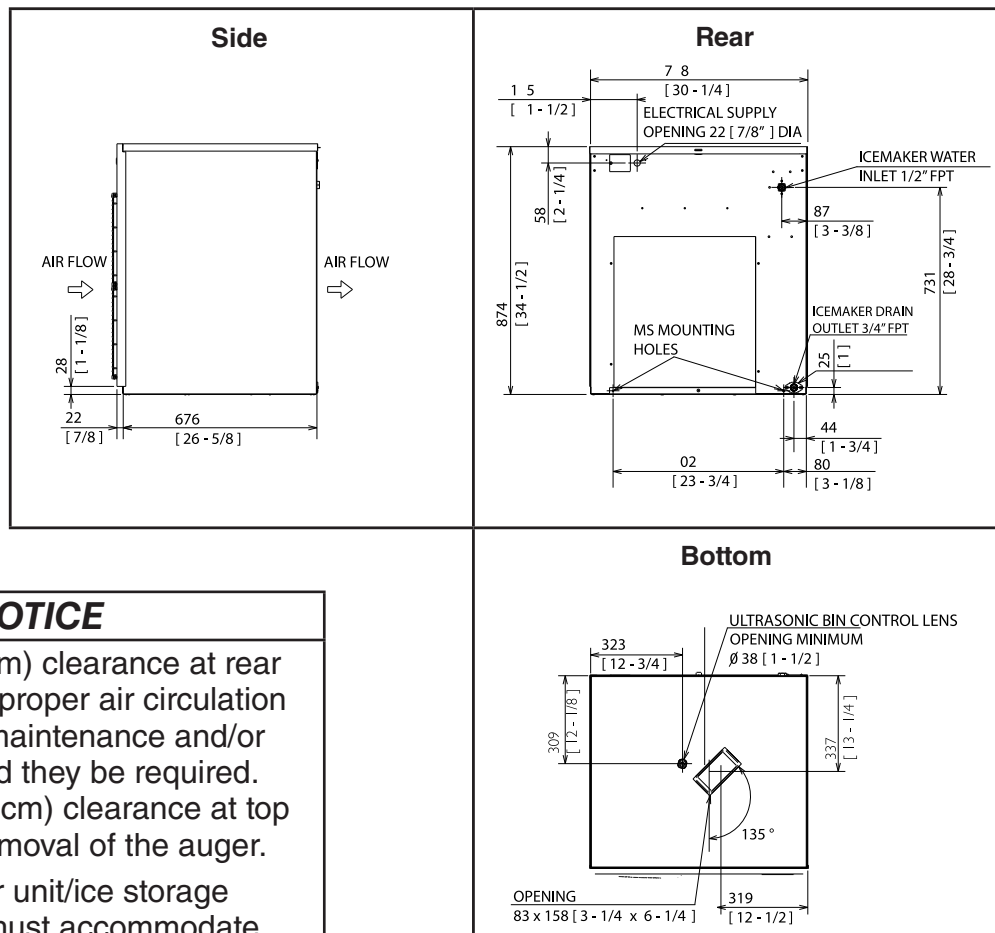

NOTICE

- Allow 6" (15-cm) clearance at rear and sides for proper air circulation and ease of maintenance and/or service should they be required. Allow 24" (61-cm) clearance at top to allow for removal of the auger.
- The dispenser unit/ice storage bin opening must accommodate the bottom opening as in the illustration.

2. Water-Cooled Models (MWJ(-C)-(-SC))

Units: mm [in.]

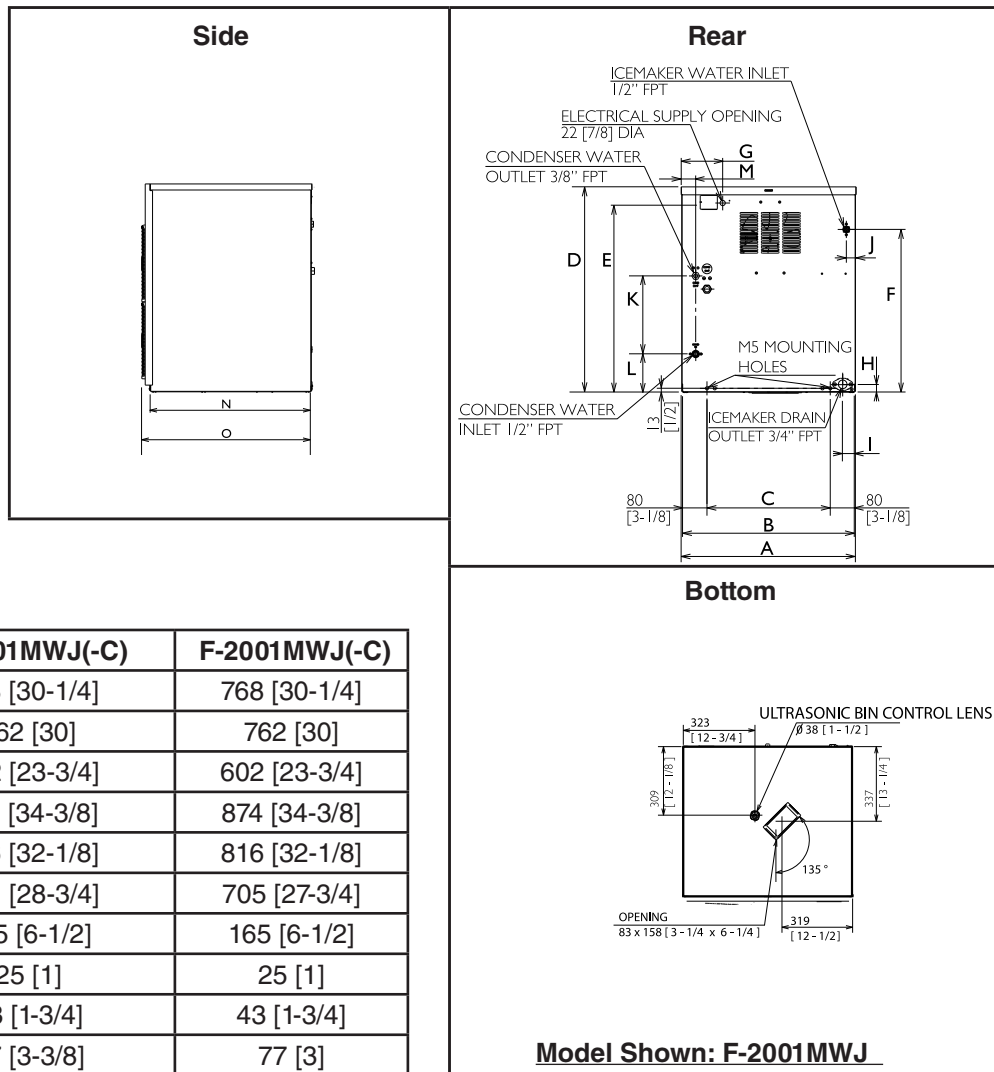

	F-1501MWJ(-C)	F-2001MWJ(-C)
A	768 [30-1/4]	768 [30-1/4]
B	762 [30]	762 [30]
C	602 [23-3/4]	602 [23-3/4]
D	874 [34-3/8]	874 [34-3/8]
E	816 [32-1/8]	816 [32-1/8]
F	731 [28-3/4]	705 [27-3/4]
G	165 [6-1/2]	165 [6-1/2]
H	25 [1]	25 [1]
I	43 [1-3/4]	43 [1-3/4]
J	87 [3-3/8]	77 [3]
K	510 [20-1/8]	508 [20]
L	139 [5-1/2]	178 [7]
M	127 [5]	51 [2]
N	676 [26-5/8]	676 [26-5/8]
O	698 [27-1/4]	698 [27-1/4]

NOTICE

- Allow 6" (15-cm) clearance at rear and sides for proper air circulation and ease of maintenance and/or service should they be required. Allow 24" (61-cm) clearance at top to allow for removal of the auger.
- The dispenser unit/ice storage bin opening must accommodate the bottom opening as in the illustration.

3. Remote Models (MRJZ/3(-C)(-SC))

Units: mm [in.]

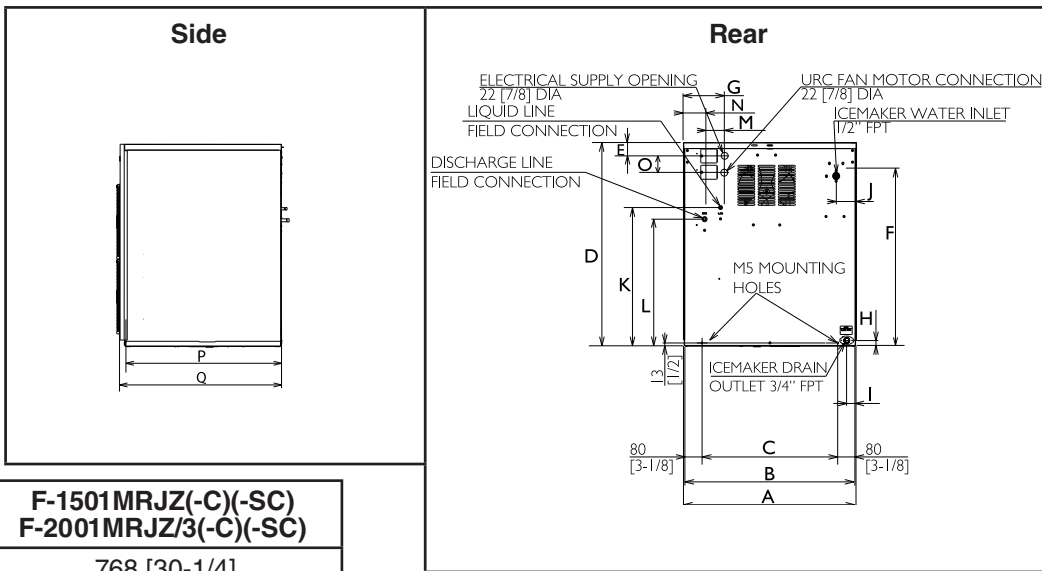

F-1501MRJZ(-C)(-SC) F-2001MRJZ/3(-C)(-SC)	
A	768 [30-1/4]
B	756 [29-3/4]
C	602 [23-3/4]
D	874 [34-3/8]
E	58 [2-1/4]
F	731 [28-13/16]
G	165 [6-1/2]
H	25 [1]
I	44 [1-3/4]
J	87 [3-7/16]
K	594.9
L	542.2 [21-3/8]
M	70.6 [2-3/4]
N	93.6 [3-5/8]
O	70.6 [2-3/4]
P	676 [26-5/8]
Q	699 [27-1/2]

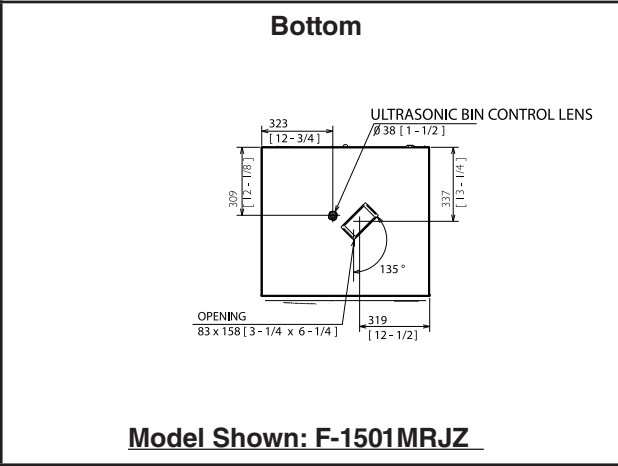

Model Shown: F-1501MRJZ

NOTICE

- Allow 6" (15-cm) clearance at rear and sides for proper air circulation and ease of maintenance and/or service should they be required. Allow 24" (61-cm) clearance at top to allow for removal of the auger.
- The dispenser unit/ice storage bin opening must accommodate the bottom opening as in the illustration.

4. Low Side, Parallel Rack System Models (F-2001MLJ)

Units: mm [in.]

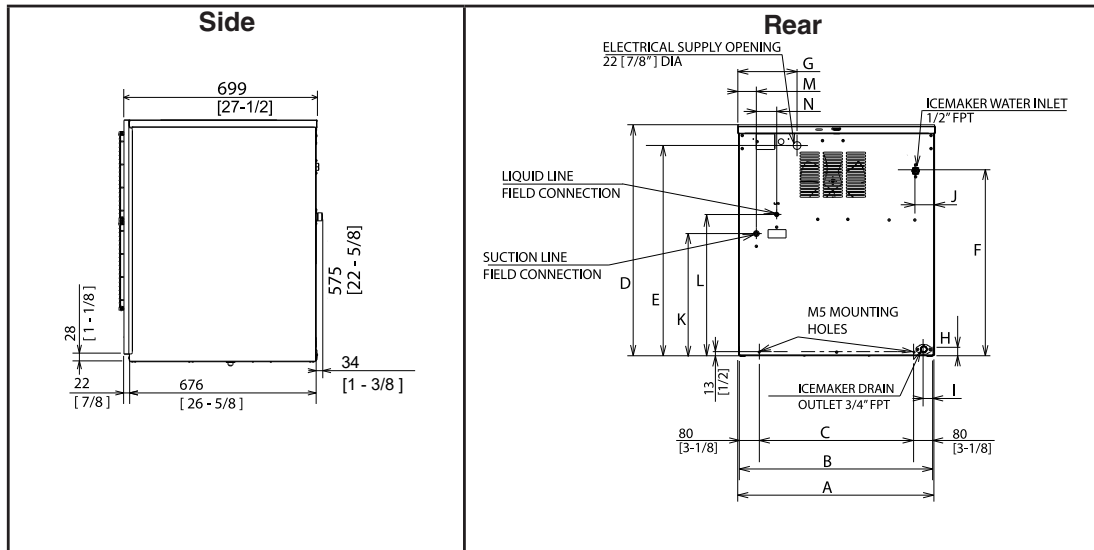

F-2001MLJ	
A	768 [30-1/4]
B	762 [30]
C	602 [23-11/16]
D	874 [34-7/16]
E	817 [32-3/16]
F	705 [27-3/4]
G	165 [6-1/2]
H	24 [15/16]
I	43 [1-11/16]
J	80 [3-1/8]
K	466 [18-3/8]
L	519 [22-1/4]
M	71 [2-1/4]
N	79 [3-1/8]

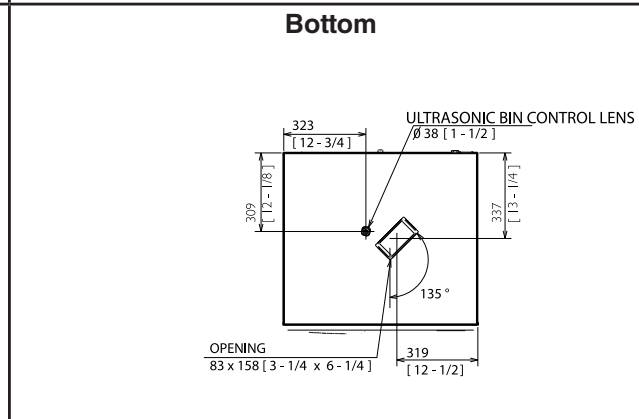

NOTICE

- Allow 6" (15-cm) clearance at rear and sides for proper air circulation and ease of maintenance and/or service should they be required. Allow 24" (61-cm) clearance at top to allow for removal of the auger.
- The dispenser unit/ice storage bin opening must accommodate the bottom opening as in the illustration.

5. Remote Condenser Unit URC-14FZ

(use with F-1501MRJZ(-C)(-SC))

NOTICE	
Allow 24" (61-cm) clearance at front and rear for proper air circulation and ease of maintenance and/or service should they be required.	

Icemaker Model	URC-14FZ Heat of Rejection AT 90°F (32°C) WT 70°F (21°C)
F-1501MRJZ(-C)(-SC)	13,194 BTU/hr

Top

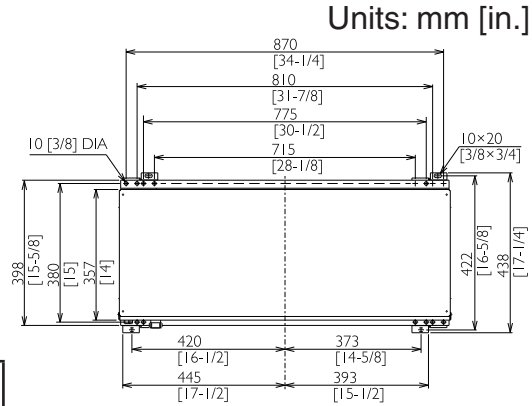

Rear

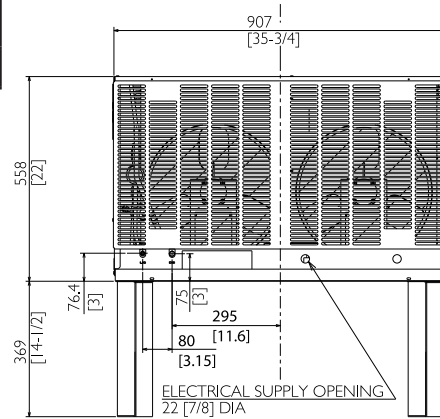

6. Remote Condenser Unit URC-22FZ

(use with F-2001MRJZ/3(-C)(-SC))

NOTICE	
Allow 24" (61-cm) clearance at front and rear for proper air circulation and ease of maintenance and/or service should they be required.	

Icemaker Model	URC-22FZ Heat of Rejection AT 90°F (32°C) WT 70°F (21°C)
F-2001MRJZ	16,475 BTU/hr
F-2001MRJZ-C(-SC)	17,690 BTU/hr
F-2001MRJZ3	16,890 BTU/hr

Top

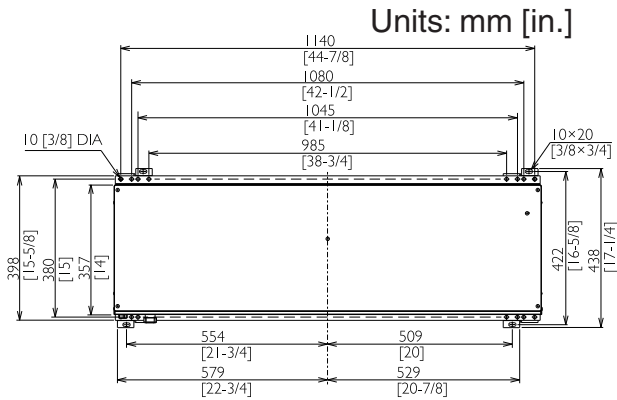

Rear

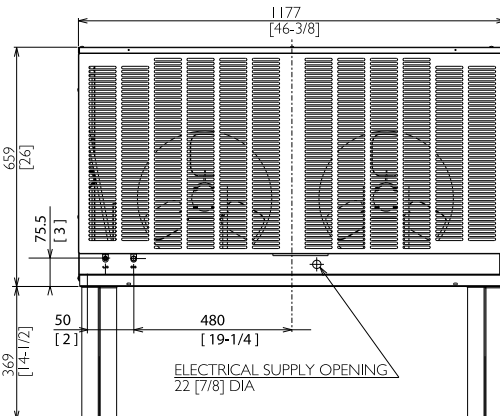

II. Installation and Operating Instructions

⚠ WARNING

- The appliance must be installed in accordance with applicable national, state, and local codes and regulations.
- Failure to install, operate, and maintain the appliance in accordance with this manual will adversely affect safety, performance, component life, and warranty coverage and may result in costly water damage.
- **CHOKING HAZARD:** Ensure all components, fasteners, and thumbscrews are securely in place after installation. Make sure that none have fallen into the dispenser unit/ice storage bin.

A. Location

NOTICE

- The icemaker is not intended for outdoor use. Normal operating ambient temperature must be within 45°F to 100°F (7°C to 38°C); Normal operating water temperature must be within 45°F to 90°F (7°C to 32°C). Operation of the icemaker, for extended periods, outside of these normal temperature ranges may affect icemaker performance.
- The icemaker will not work at sub-freezing temperatures. To prevent damage to the water supply line, drain the icemaker if the air temperature is going to go below 32°F (0°C). See "IV. Preparing the Appliance for Periods of Non-Use."

- The icemaker should not be located next to ovens, grills, or other high heat producing equipment.
- Allow 6" (15-cm) clearance at rear and sides for proper air circulation and ease of maintenance and/or service should they be required. Allow 24" (61-cm) clearance at top to allow for removal of the auger.
- The location should provide a firm and level foundation for the appliance.

B. Checks Before Installation

- Visually inspect the exterior of the shipping container and immediately report any damage to the carrier. Upon opening the container, any concealed damage should also be immediately reported to the carrier.
- Remove the shipping carton, tape, and packing material. If any are left in the appliance, it will not work properly.
- See the nameplate on the rear panel, and check that your voltage supplied corresponds with the voltage specified on the nameplate.
- Remove the panels to prevent damage when installing the appliance. See "II.C. How to Remove Panels."
- Remove the package containing the accessories.
- Remove the protective plastic film from the panels. If the appliance is exposed to the sun or to heat, remove the film after the appliance cools.

- Check that the refrigerant lines do not rub or touch lines or other surfaces, and that the fan blade (if applicable) turns freely.
- Check that the compressor is snug on all mounting pads.
- Flaker and soft cubelet (-SC) models can be installed on an ice storage bin only. Cubelet models can be installed on either a cubelet-compatible dispenser unit or an ice storage bin. The ice storage bins listed below are recommended.

Model Number	Bin Width	Recommended Hoshizaki Ice Storage Bin
F-1501M_J(Z)(-C)(-SC) F-2001M_J(Z)/3(-C)(-SC)	30" or Wider	B-500 Series

For further options, contact your local Hoshizaki distributor.

- **NOTICE! Remote models must be connected to an appropriate remote condenser unit. The remote condenser units listed below are recommended. Connection to a different remote condenser unit will void the warranty unless Hoshizaki approves a different remote condenser unit for your specific application. For further details, contact your local Hoshizaki distributor.**

Model Number	Recommended Hoshizaki Remote Condenser Unit
F-1501MRJZ(-C)(-SC)	URC-14FZ
F-2001MRJZ/3(-C)(-SC)	URC-22FZ

- On low-side models, an R-404A, R-407A, or R-407F parallel rack system is needed. See "II.H. Parallel Rack System Connection" for refrigeration circuit details.

C. How to Remove Panels

See Fig. 1

- Front Panel: Remove the screw. Lift up and towards you.
- Top Panel: Lift up at front slightly, push rearward and lift off.
- Side Panels: Remove the screw. Slide forward slightly and lift off.

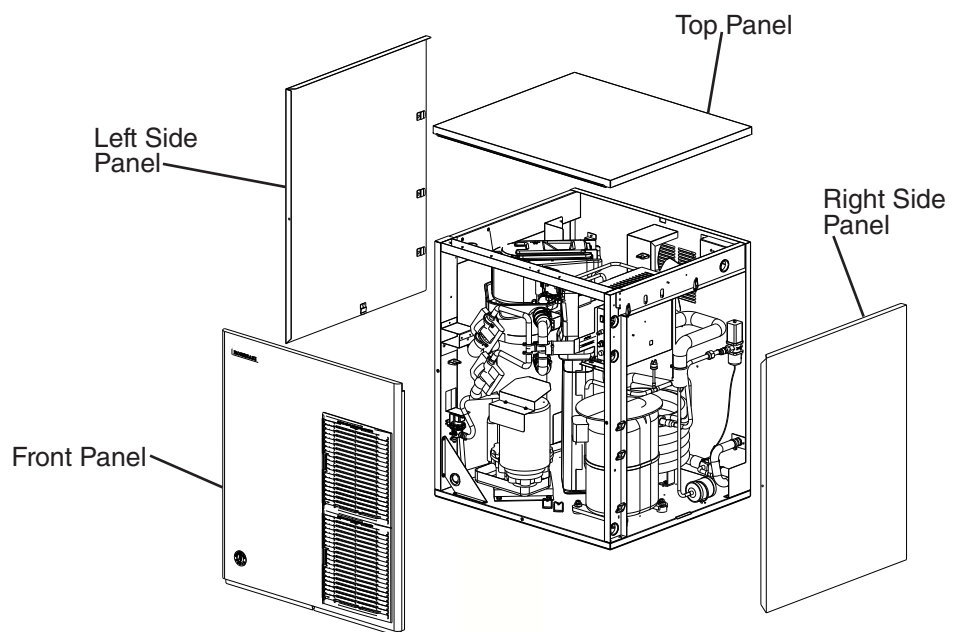

Fig. 1

Model Shown: F-1501MWJ

D. Dispenser Unit/Ice Storage Bin and Icemaker Setup

⚠ WARNING

The installer must ensure the dispenser unit/ice storage bin is compatible with the icemaker, and the dispenser unit/ice storage bin and icemaker are properly attached and secured.

- 1a) **Dispenser Unit:** Follow the dispenser unit's setup procedure. Note that only cubelet models can be installed on a cubelet-compatible dispenser unit; flaker and soft cubelet (-SC) models cannot be installed on a dispenser unit.
- 1b) **Ice Storage Bin:** Unpack the ice storage bin and attach the 4 adjustable legs provided (bin accessory) to the bottom of the ice storage bin.
 - 2) Position the dispenser unit/ice storage bin in its permanent location.
 - 3) If required, install an adapter kit or top kit. Contact your local Hoshizaki distributor for recommendations.
 - 4) Level the dispenser unit/ice storage bin in both the left-to-right and front-to-rear directions. If using an ice storage bin, adjust the ice storage bin legs to level.
 - 5) Place the icemaker on top of the dispenser unit/ice storage bin.
- 6a) **Dispenser Unit:** Follow the dispenser unit, adapter kit, or top kit instructions for securing the icemaker. If no instructions are available, secure the icemaker using the mounting brackets provided. Rotate the mounting brackets so that they fit flush to the dispenser unit. See Fig. 2a. Secure the mounting brackets to the icemaker with the bolts provided. Secure the mounting brackets to the dispenser unit with self-tapping screws (not provided). **NOTICE! Use care to avoid damage to dispenser unit components when attaching the mounting brackets.**
- 6b) **Ice Storage Bin:** Follow the ice storage bin, adapter kit, or top kit instructions for securing the icemaker. If no instructions are available, secure the icemaker using the 2 mounting brackets and the bolts provided. See Fig. 2b.

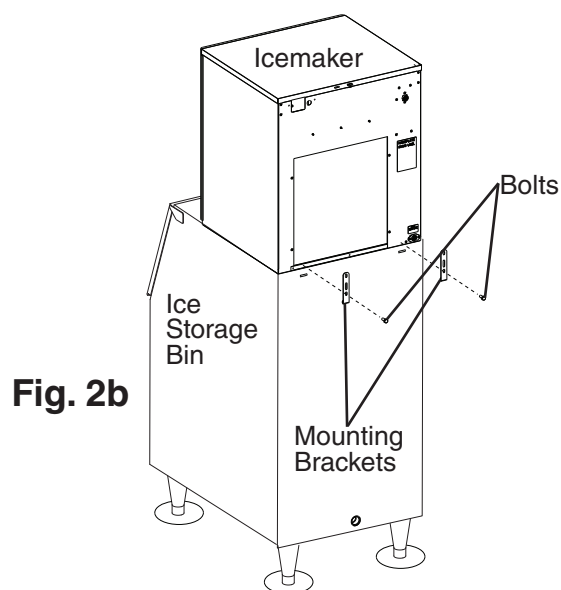
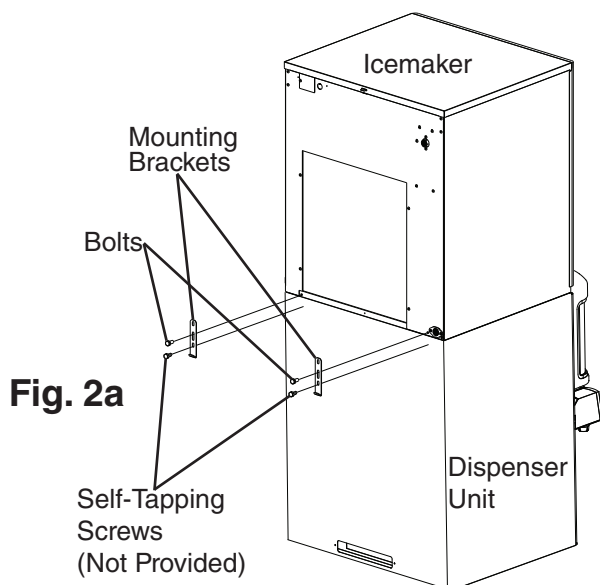

Model Shown: F-1501MAJ

E. Electrical Connection

⚠ WARNING

For All Models

- Electrical connection must be hard-wired and must meet national, state, and local electrical code requirements. Failure to meet these code requirements could result in death, electric shock, serious injury, fire, or damage.
- The icemaker requires an independent power supply of proper capacity. See the nameplate for electrical specifications. Failure to use an independent power supply of proper capacity can result in a tripped breaker, blown fuse, damage to existing wiring, or component failure. This could lead to heat generation or fire.
- **THE ICEMAKER MUST BE GROUNDED.** Failure to properly ground the icemaker could result in death or serious injury.
- Electrical connection must be made in accordance with the instructions on the "WARNING" tag, provided with the pig tail leads in the junction box. See Fig. 3.

Additional Warnings for Remote Models

- **THE REMOTE CONDENSER UNIT MUST BE GROUNDED.** Power supply and ground wire to the remote condenser unit are supplied from the icemaker. See "II.G.6. Electrical Connection." Failure to properly ground the remote condenser unit could result in death or serious injury.
- To reduce the risk of electric shock, make all remote condenser unit connections before connecting the icemaker power supply.

NOTICE

On remote models, the appliance must have power for a minimum of 4 hours prior to startup to prevent compressor damage.

- Usually an electrical permit and services of a licensed electrician are required.
- The maximum allowable voltage variation is ± 10 percent of the nameplate rating.
- On single phase models, the white lead must be connected to the neutral conductor of the power source. **NOTICE! Miswiring may result in damage to the icemaker.**
- **NOTICE! On three phase models, the transformer's voltage tap switch must be positioned to match incoming voltage at startup.**
- **NOTICE! On three phase models, connect the highest incoming voltage supply ("stinger leg") to the power wire dedicated to the compressor. See the wiring label on the icemaker.**
- The opening for the power supply connection is 7/8" DIA to fit a 1/2" trade size conduit.

F-1501M_J(Z)(-C)(-SC) F-2001M_J(Z)(-C)(-SC)	F-2001MRJZ3	F-2001MLJ
<p>⚠ WARNING ELECTRICAL CONNECTION</p> <p>THIS UNIT MUST BE GROUNDED Failure to properly ground or wire this unit could result in death, serious injury, or severe damage to the icemaker. The white lead must be connected to the neutral conductor of the power source. See diagram below.</p> <p>208-230/60/1 (3 wire with neutral for 115V)</p> 	<p>⚠ WARNING ELECTRICAL CONNECTION</p> <p>THIS UNIT MUST BE GROUNDED Failure to properly ground or wire this unit could result in death, serious injury, or severe damage to the icemaker. This unit must be connected to a three-phase power source. The transformer's voltage tap switch must be positioned to match incoming voltage at startup. See diagram below.</p> <p>208-230/60/3</p> 	<p>⚠ WARNING ELECTRICAL CONNECTION</p> <p>THIS UNIT MUST BE GROUNDED Failure to properly ground or wire this unit could result in death, serious injury, or severe damage to the icemaker. The white lead must be connected to the neutral conductor of the power source. See diagram below.</p> <p>115/60/1</p> 

Fig. 3

F. Water Supply and Drain Connections

See Fig. 4, 5, and 6

⚠ WARNING

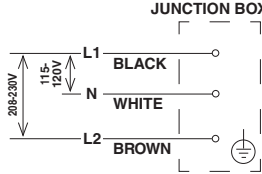
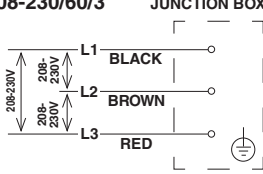
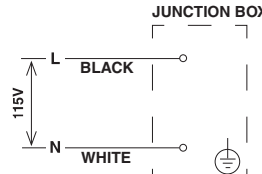
Water supply and drain connections must be installed in accordance with applicable national, state, and local regulations.

NOTICE

- Normal operating water temperature must be within 45°F to 90°F (7°C to 32°C). Operation of the appliance, for extended periods, outside of this normal temperature range may affect appliance performance.
 - Water supply pressure must be a minimum of 10 PSIG and a maximum of 113 PSIG. If the pressure exceeds 113 PSIG, the use of a pressure reducing valve is required.
 - External filters, strainers, or softeners may be required depending on water quality. Contact your local Hoshizaki Certified Service Representative or local Hoshizaki distributor for recommendations.
-
- A plumbing permit and services of a licensed plumber may be required in some areas.
 - The icemaker drain line, dispenser unit/ice storage bin drain line, and water-cooled condenser drain line (if applicable) must be run separately.
 - Drain lines must have 1/4" fall per foot (2 cm per 1 m) on horizontal runs to get a good flow. A vented tee connection is also required for proper flow.
 - Drain lines should not be piped directly to the sewer system. An air gap of a minimum of 2 vertical inches (5-cm) must be between the end of the drain pipes from the icemaker, dispenser unit/ice storage bin, and water-cooled condenser (if applicable) and the floor drain.

1. Icemaker

Icemaker Water Supply Inlet	Minimum Icemaker Water Supply Line Size	Icemaker Drain Outlet	Minimum Icemaker Drain Line Size
1/2" Female Pipe Thread (FPT)	1/4" Nominal ID Copper Water Tubing or Equivalent	3/4" Female Pipe Thread (FPT)	3/4" Nominal ID Hard Pipe or Equivalent

- An icemaker water supply line shut-off valve and drain valve must be installed.
- Be sure there is sufficient extra water supply line and drain line for the appliance to be pulled out for service.

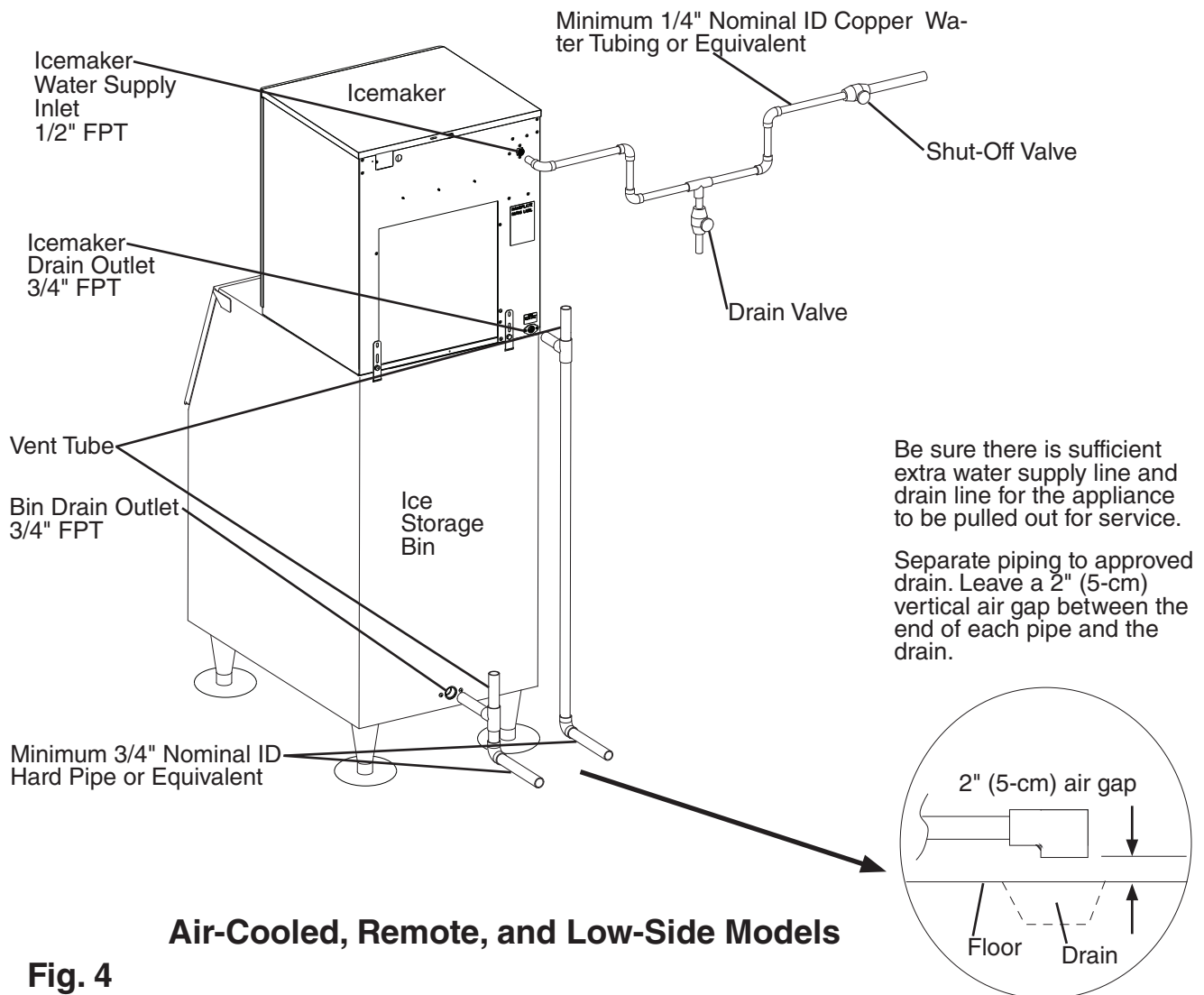

Fig. 4

2. Water-Cooled Condenser

a) Connection to an Open Drain System

Condenser Water Supply Inlet	Minimum Condenser Water Supply Line Size	Condenser Drain Outlet	Minimum Condenser Drain Line Size
1/2" Female Pipe Thread (FPT)	1/4" Nominal ID Copper Water Tubing or Equivalent	3/8" Female Pipe Thread (FPT)	1/4" Nominal ID Hard Pipe or Equivalent

- A condenser water supply line shut-off valve and drain valve must be installed.
- In some areas, a back flow preventer may be required in the cooling water circuit.
- In order to maintain the proper high side pressure, the condenser water supply inlet temperature should not drop below 45°F (7°C) and the condenser drain outlet temperature must be in the 104°F to 115°F (40°C to 46°C) range. Once the icemaker installation is complete, confirm the condenser drain outlet temperature 5 minutes after a freeze cycle starts. If the condenser drain outlet temperature is not in the proper range, use a flat blade screwdriver to rotate the adjustment screw on the water-regulating valve until the temperature is in the proper range (rotate counterclockwise to raise temperature or clockwise to lower temperature).

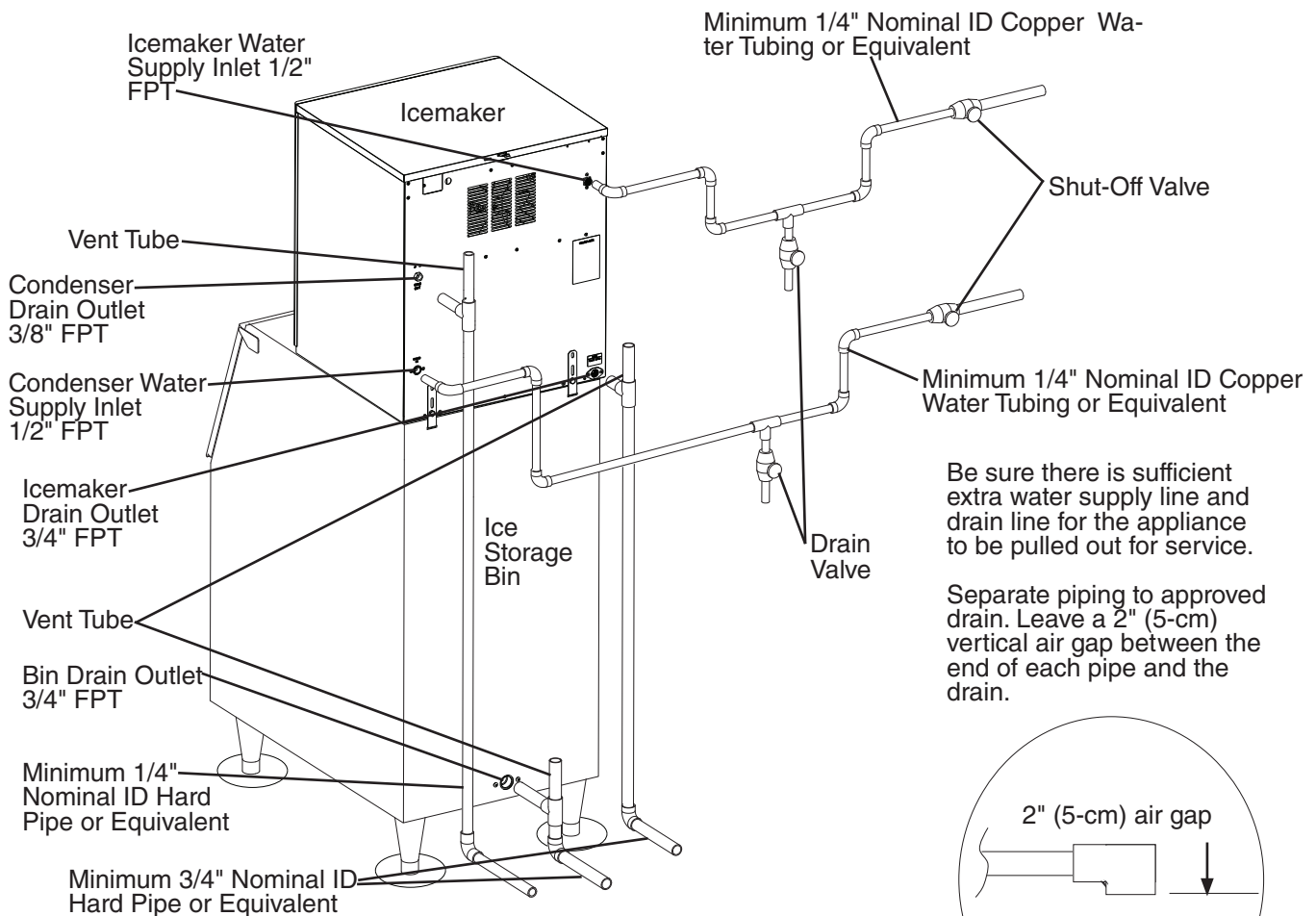

Fig. 5

**Water-Cooled Models
Connection to an Open Drain System**

b) Connection to a Closed Loop System

Condenser Water Supply Inlet	Minimum Condenser Water Supply Line Size	Condenser Return Outlet	Minimum Condenser Return Line Size
1/2" Female Pipe Thread (FPT)	1/4" Nominal ID Copper Water Tubing or Equivalent	3/8" Female Pipe Thread (FPT)	1/4" Nominal ID Copper Water Tubing or Equivalent

- Shut-off valves and drain valves must be installed at both the condenser water supply inlet and condenser return outlet.
- Minimum water flow to the condenser is 4 GPM.
- The pressure differential between the condenser water supply inlet and condenser return outlet must be no less than 10 PSIG.
- When using a glycol blend, the solution mixture must be less than 30% glycol.
- In order to maintain the proper high side pressure, the condenser water supply inlet temperature should not drop below 45°F (7°C) and the condenser return outlet temperature must be in the 104°F to 115°F (40°C to 46°C) range. Once the icemaker installation is complete, confirm the condenser return outlet temperature 5 minutes after a freeze cycle starts. If the condenser return outlet temperature is not in the proper range, use a flat blade screwdriver to rotate the adjustment screw on the water-regulating valve until the temperature is in the proper range (rotate counterclockwise to raise temperature or clockwise to lower temperature).

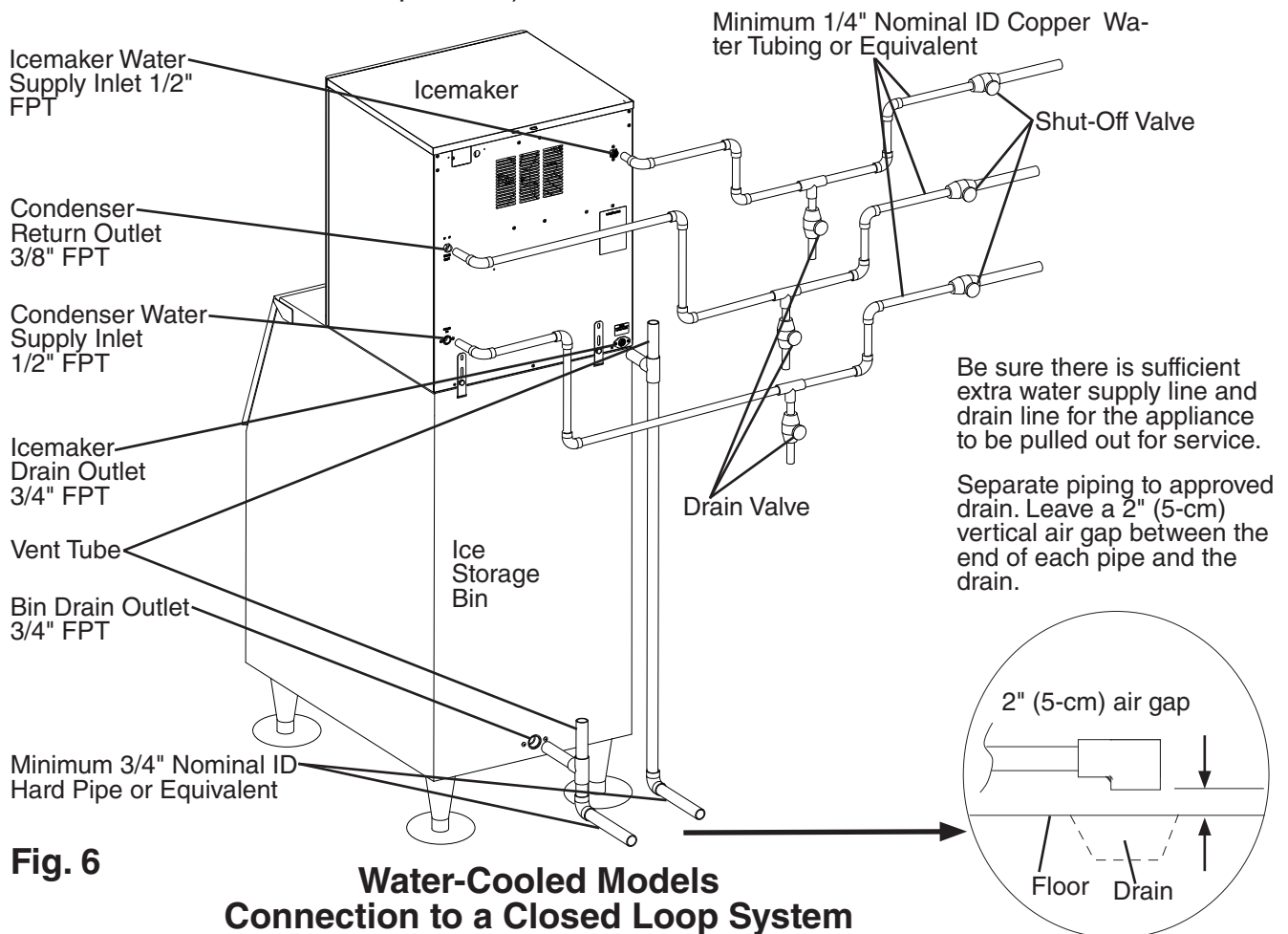

Fig. 6

**Water-Cooled Models
Connection to a Closed Loop System**

G. Remote Condenser Unit Installation

⚠ WARNING

- Installation of remote condenser unit must be performed by properly trained and EPA-certified service personnel.
- The remote condenser unit must be installed in accordance with applicable national, state, and local codes and regulations.
- Failure to install the remote condenser unit within these guidelines may adversely affect safety, performance, component life, and warranty coverage.
- Power supply and ground wire to the remote condenser unit are supplied from the icemaker. For details, see section "II.G.6. Electrical Connection."

1. Location

NOTICE

- The remote condenser unit is intended for outdoor use. Normal operating ambient temperature must be within -20°F to $+122^{\circ}\text{F}$ (-29°C to $+50^{\circ}\text{C}$). Operation of the remote condenser unit, for extended periods, outside of this normal temperature range may affect appliance performance.
- The maximum line length for the standard line sizes and refrigerant charge is 66' (20 m). With larger line sizes and/or additional refrigerant, the maximum line length is 100' (30.5 m). For details, see "II.G.4 Line Set Size and Refrigerant Charge."
- The maximum vertical distance between the remote condenser unit and the icemaker is 33' (10 m) above or 10' (3 m) below the icemaker. These distances are measured fitting to fitting. See Fig. 7.

The remote condenser unit must be positioned in a permanent site under the following guidelines:

- A firm and flat site.
- A dry and well ventilated area with 24" (61 cm) clearance at front and rear for proper air circulation and ease of maintenance and/or service should they be required. See Fig. 8.

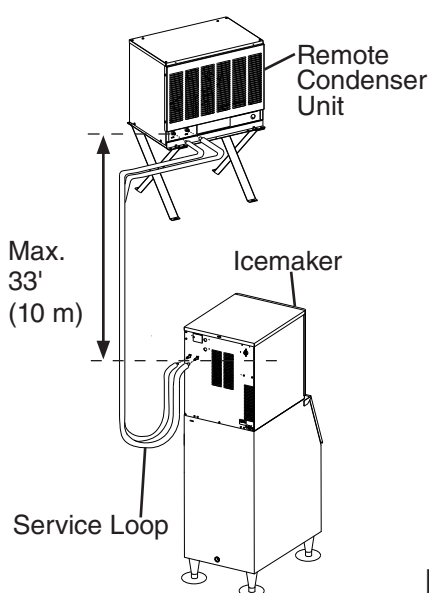

Fig. 7

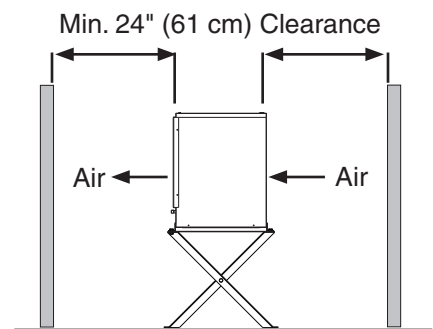
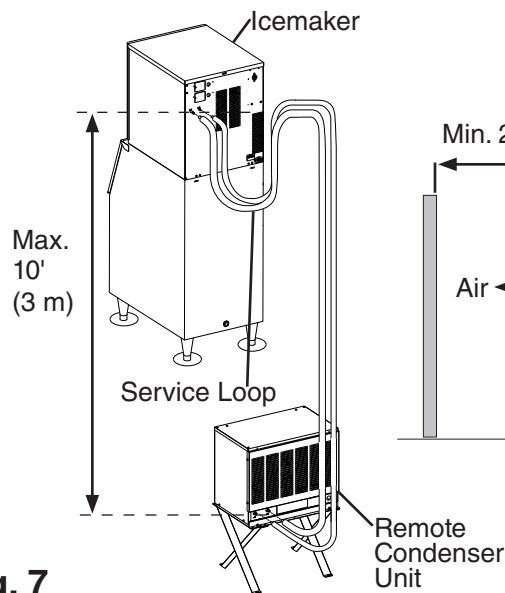

Fig. 8

2. Checks Before Installation

- 1) Remove the shipping carton, tape, and packing material.
- 2) Check that the refrigerant lines do not rub or touch lines or other surfaces, and that the fan blades move freely.

3. Setup

- 1) Assemble 2 sets of legs using the legs, bolts, and nuts provided. See Fig. 9
- 2) Position 1 of the plates provided between a set of legs and the remote condenser unit, then secure the legs to the remote condenser unit with the bolts and nuts provided. Repeat on the other side with the remaining set of legs.
- 3) The bottom of each leg has a mounting hole. Secure the legs to the permanent site with 4 bolts (not included).

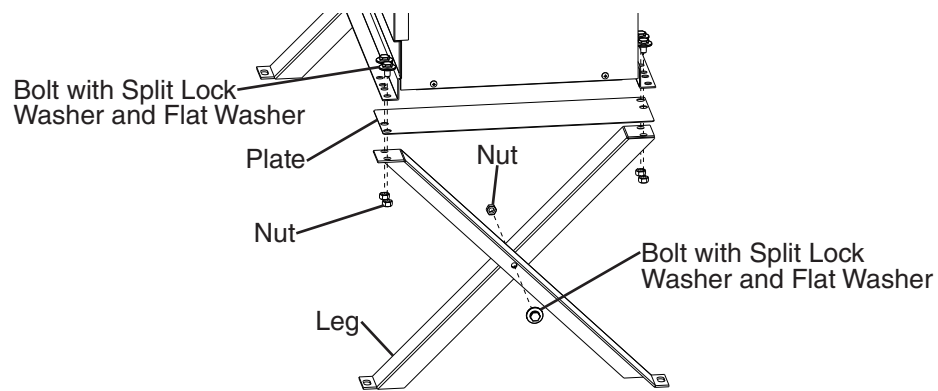

Fig. 9

4. Line Set Size and Refrigerant Charge

NOTICE

The icemaker, line set, and remote condenser unit must contain the same type of refrigerant. Mixing of refrigerants will result in improper operation and possible damage to the refrigeration system.

Line Set Size and Refrigerant Charge							
Hoshizaki Icemaker	Hoshizaki Remote Condenser Unit	Line Set Up to 66' (20 m)			Line Set Greater than 66' (20 m) Maximum 100' (30.5 m)		
		Liquid Line	Discharge Line	Charge Adjustment	Liquid Line	Discharge Line	Charge Adjustment (R-404A)
F-1501MRJZ(-C)(-SC)	URC-14FZ	3/8" OD	1/2" OD	Not Applicable	3/8" OD	1/2" OD	Add 0.4 oz. for each foot over 66' (40 g for each meter over 20 m). Write new total charge on icemaker's rating label.
F-2001MRJZ/3(-C)(-SC)	URC-22FZ	3/8" OD	5/8" OD	Not Applicable	3/8" OD	5/8" OD	

5. Line Set Installation

⚠ WARNING

- R-404A itself is not flammable at atmospheric pressure and temperatures up to 176°F (80°C).
- R-404A itself is not explosive or poisonous. However, when exposed to high temperatures (open flames), R-404A can be decomposed to form hydrofluoric acid and carbonyl fluoride both of which are hazardous.
- Do not use silver alloy or copper alloy containing arsenic.
- Use an electronic leak detector or soap bubbles to check for leaks. Add a trace of refrigerant to the line set tubing through the service valve access ports (if using an electronic leak detector), and then raise the pressure using nitrogen gas (140 PSIG). Do not use R-404A as a mixture with pressurized air for leak testing.

NOTICE

- Do not open any service valve until the line set installation is complete and leak tested.
- Ensure that there are no traps and no kinks in the line set.
- Do not coil extra line set.

- 1) Route the factory line set or appropriate size copper tubing. When field fabricating, insulate the copper tubes separately. Leave a service loop behind the icemaker to allow the icemaker to be pulled out for service. See Fig. 7.
Note:
 - The service loop is not considered an oil trap.
 - The maximum line length for the standard line sizes and refrigerant charge is 66' (20 m). With additional refrigerant, the maximum line length is 100' (30.5 m). For details, see "I.G.4 Line Set Size and Refrigerant Charge."
- 2) Remove any extra line set length, then insulate the two copper tubes separately.
- 3) Remove the Schrader valves from the icemaker service valves.
- 4) Braze the line set copper tubes to the icemaker liquid and discharge line service valves.

NOTICE

- Before brazing, remove the Schrader valve cores from the service valve access ports.
- When brazing, protect the service valve by using a wet cloth to prevent the service valve from overheating.
- Braze all fittings while purging with nitrogen gas flowing at a pressure of 3 to 4 PSIG.

- 5) Remove the Schrader valves from the condenser unit service valves.
- 6) Braze the line set copper tubes to the condenser unit liquid and discharge line service valves.
- 7) Allow the service valves to cool, then replace the Schrader valve cores. Attach the gauge manifold hoses.

- 8) Use an electronic leak detector or soap bubbles to check for leaks. Add a trace of refrigerant to the line set tubing through the service valve access ports (if using an electronic leak detector), and then raise the pressure using nitrogen gas (140 PSIG).
WARNING! Do not use R-404A as a mixture with pressurized air for leak testing.
- 9) After checking the line set for leaks, vent the nitrogen charge from the line set.
- 10) Evacuate the line set. Allow the vacuum pump to pull down to a 29.9" Hg vacuum
Evacuating period depends on pump capacity.
- 11) After evacuation, charge each line set tube with R-404A vapor to a pressure of 15 to 30 PSIG.
- 12) Close both gauge manifold valves.
- 13) If the line set exceeds 66' (20 m), see "II.G.4. Line Set Size and Refrigerant Charge" for proper charging of the appliance. If not, continue to step 14.
- 14) Open the icemaker service valves first, then open the remote condenser unit service valves.
- 15) Disconnect the gauge manifold hoses.
- 16) Replace all service valve caps and tighten.
- 17) Insulate all exposed tubing and fittings.

6. Electrical Connection

⚠ WARNING

- Electrical connection must meet national, state, and local electrical code requirements. Failure to meet these code requirements could result in death, electric shock, serious injury, fire, or damage.
- To reduce the risk of electric shock, make all remote condenser unit connections before connecting the icemaker power supply.
- **THE REMOTE CONDENSER UNIT MUST BE GROUNDED.** Install a ground wire from the icemaker fan motor junction box to the remote condenser unit junction box. Use wire of an appropriate gage and outdoor rating. Failure to properly ground the remote condenser unit could result in death or serious injury.
- Install line and neutral wires from the fan motor leads in the icemaker fan motor junction box to the leads in the remote condenser unit junction box. Use wire of an appropriate gage and outdoor rating.
- Do not connect the fan motor leads in the icemaker to incoming power source. Do not connect the fan motor leads in the icemaker together. Do not allow the leads to contact the junction box walls.
- Do not connect the remote condenser unit to an external power source.

NOTICE

On remote models, the appliance must have power for a minimum of 4 hours prior to startup to prevent compressor damage.

- Usually an electrical permit and services of a licensed electrician are required.
 - The opening for the power supply connection is 7/8" DIA to fit a 1/2" trade size conduit.
- 1) Remove the remote condenser unit louver panel. See Fig. 10.
 - 2) Remove the icemaker fan motor junction box cover. Remove the remote condenser unit junction box cover.

Fig. 10

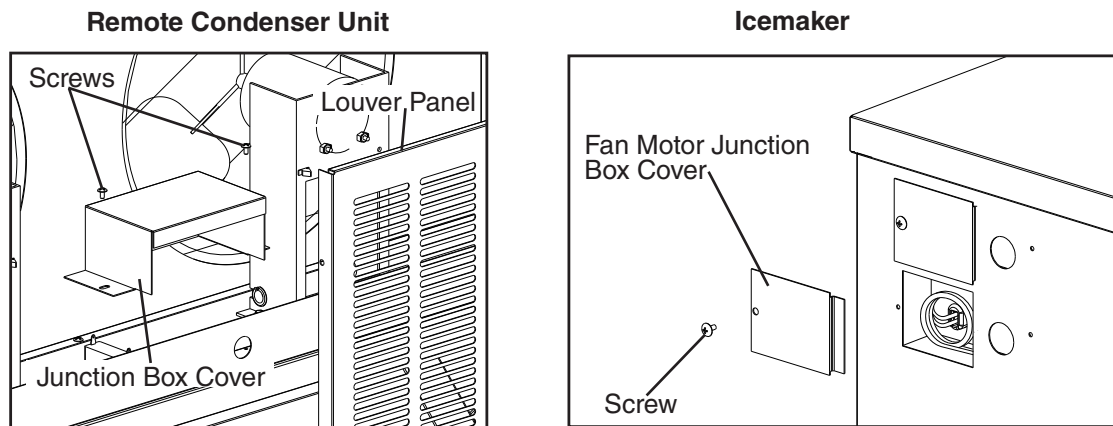

- 3) Install a ground wire from the icemaker fan motor junction box to the remote condenser unit junction box. Use wire of an appropriate gage and outdoor rating.
- 4) Install line and neutral wires from the fan motor leads in the icemaker fan motor junction box to the leads in the remote condenser unit junction box. Use wire of an appropriate gage and outdoor rating.
- 5) Replace the junction box covers and the louver panel in their correct positions.

7. Stacking Remote Condenser Unit

- 1) Install the lower remote condenser unit as described earlier in this section.
- 2) Place the upper remote condenser unit on top of the lower remote condenser unit. See Fig. 11.
- 3) Secure the upper remote condenser unit to the lower remote condenser unit with the 4 screws provided.
- 4) Install refrigerant lines and make electrical connection as described earlier in this section.

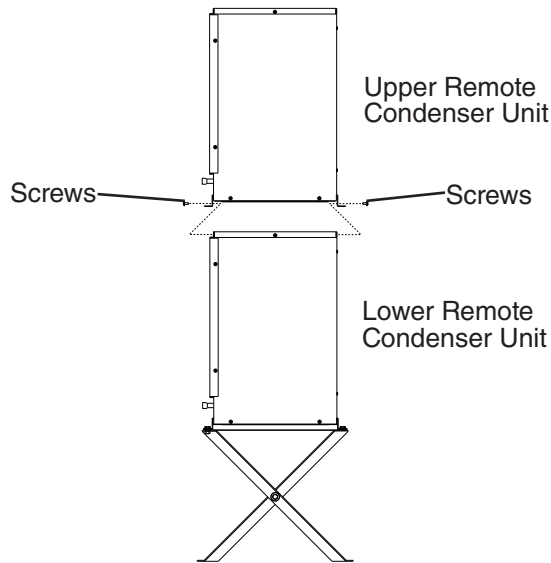

Fig. 11

H. Parallel Rack System Connection

⚠ WARNING

- Installation must be performed by properly trained and EPA-certified service personnel.
- Failure to install the appliance within these guidelines may adversely affect safety, performance, component life, and warranty coverage.
- Connect the line set to the rack system per the rack system manufacturer's instructions.

NOTICE

- The icemaker is shipped with a nitrogen holding charge. Nitrogen must be vented from multiple points prior to evacuating the refrigeration circuit.
- The icemaker, line set, and rack system must contain the same type of refrigerant. Mixing of refrigerants will result in improper operation and possible damage to the refrigeration system.
- Ensure that there are no traps and no kinks in the line set. The service loop is not considered an oil trap.
- Icemaker may be used with refrigerants 404A, 407A, or 407F. See table below for EPR valve settings.

1. Line Set Size and Rack System Requirements

Line Set Size and Rack System Requirements				
Hoshizaki Icemaker	Liquid Line	Suction Line	Maximum Load at 90°F (32°C) Ambient 70°F (21°C) Water	Suction Pressure (Evaporator Pressure Regulator (EPR) Valve is factory adjusted for R-404A. Adjust only if necessary.)
F-2001MLJ	3/8" OD	5/8" OD	11,600 BTU/hr	R-404A - 22 PSIG R-407A - 14 PSIG R-407F - 15 PSIG

- Install a p-trap in the suction line if required by the rack system manufacturer's instructions.

2. Line Set Installation

⚠ WARNING

- Do not use silver alloy or copper alloy containing arsenic.
- Use an electronic leak detector or soap bubbles to check for leaks. Add a trace of refrigerant to the line set tubing through the service valve access ports (if using an electronic leak detector), and then raise the pressure using nitrogen gas (140 PSIG). Do not use refrigerant as a mixture with pressurized air for leak testing.

NOTICE

- Do not open any service valve until the line set installation is complete and leak tested.
- Ensure that there are no traps and no kinks in the line set.
- Do not coil extra line set.

- 1) Route the proper size copper tube liquid line and copper tube suction line (see "II.H.1 Line Set Size and Rack System Requirements" for details) from the rack system to the icemaker. Leave a service loop behind the icemaker to allow the icemaker to be pulled out for service. See Fig. 12. Note: The service loop is not considered an oil trap.
- 2) Remove any extra line set length, then insulate the two copper tubes separately.
- 3) Remove the Schrader valves from the icemaker service valves.
- 4) Braze the line set copper tubes to the icemaker liquid and suction line service valves.

NOTICE

- Before brazing, remove the Schrader valve cores from the service valve access ports.
- When brazing, protect the service valve by using a wet cloth to prevent the service valve from overheating.
- Braze all fittings while purging with nitrogen gas flowing at a pressure of 3 to 4 PSIG.

- 5) If applicable, remove the rack system service valve Schrader valve core. Connect the rack system end of the line set per the rack system instructions. **NOTICE! Do not open the rack system service valves at this time.**
- 6) Allow the service valves to cool, then replace the Schrader valve cores in the icemaker service valves and rack system service valves (if applicable). Attach the gauge manifold hoses.
- 7) Use an electronic leak detector or soap bubbles to check for leaks. Add a trace of refrigerant to the line set tubing through the service valve access ports (if using an electronic leak detector), and then raise the pressure using nitrogen gas (140 PSIG). **WARNING! Do not use refrigerant as a mixture with pressurized air for leak testing.**

- 8) After checking the line set for leaks, vent the line set nitrogen charge. Next, open both icemaker service valves and vent the icemaker nitrogen holding charge.
- 9) After venting the icemaker nitrogen holding charge, evacuate the icemaker and line set. Allow the vacuum pump to pull down to a 29.9" Hg vacuum. Evacuating period depends on pump capacity.
- 10) After evacuation, charge the icemaker and line set with refrigerant vapor (R-404A, R-407A, or R-407F) to a pressure of 15 to 30 PSIG.
- 11) Close both gauge manifold valves.
- 12) Open the rack system service valves.
- 13) Disconnect the gauge manifold hoses.
- 14) Replace all service valve caps and tighten.
- 15) Insulate all exposed tubing and fittings.

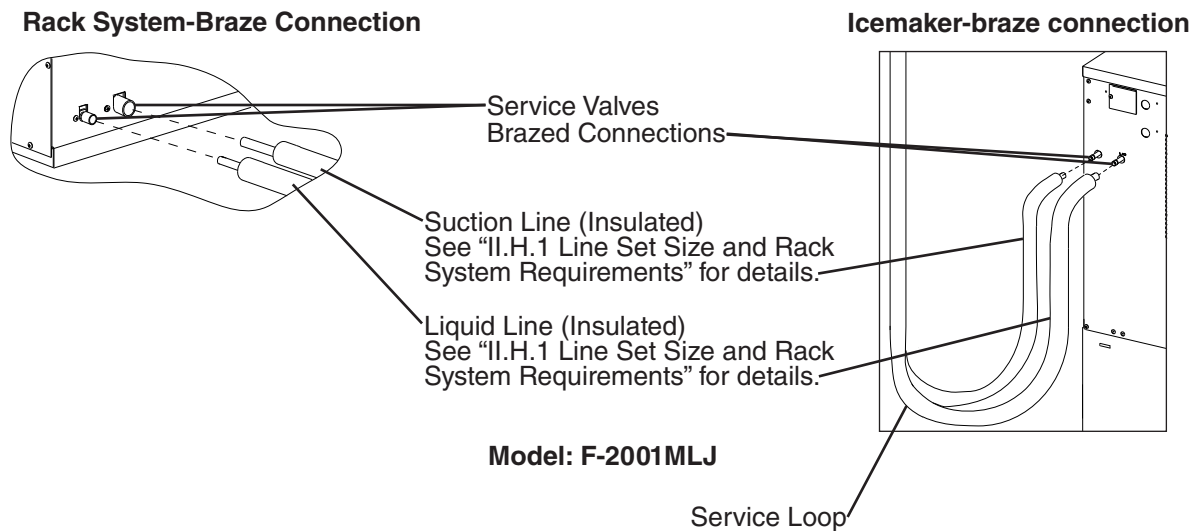

Fig. 12

I. Final Checklist

1. Pre-Startup

- 1) Is the icemaker level?
- 2) Is the icemaker in a site where the ambient temperature is within 45°F to 100°F (7°C to 38°C) and the water temperature within 45°F to 90°F (7°C to 32°C) all year around?
- 3) Is there at least 6" (15-cm) clearance at rear and sides and 24" (61-cm) at the top of the icemaker?
- 4) Have the shipping carton, tape, and packing material been removed from the appliance?
- 5) Have all electrical and water connections been made? Do electrical and water connections meet applicable national, state, and local code and regulation requirements?
- 6) Has the power supply voltage been checked or tested against the nameplate rating? Has a proper ground been installed to the icemaker? On remote models, has a proper ground also been installed to the remote condenser unit?
- 7) Are the water supply and drain lines sized as specified? Are the water supply line shut-off valve(s) and drain valve(s) installed? Has the water supply pressure been checked to ensure a minimum of 10 PSIG and a maximum of 113 PSIG?
- 8) Is the compressor snug on all mounting pads? Have the refrigerant lines been checked to make sure they do not rub or touch other lines or surfaces? Has the fan blade (if applicable) been checked to make sure it turns freely?
- 9) On remote and low side, parallel rack system models, is the line set sized as specified, insulated, tightened, and free of leaks and kinks?
- 10) On remote models:
 - If the line set exceeds 66' (20 m), has the charge been adjusted as specified?
 - Has the appliance power supply been on for a minimum of 4 hours?
 - Is the remote condenser unit in a site where the ambient temperature is within -20°F to +122°F (-29°C to +50°C) all year around?
 - Is there at least 24" (61-cm) clearance around the remote condenser unit?
- 11) On low-side rack systems, has the rack system's service valves been opened.
- 12) Continue to "II.J. Startup".

2. Post-Startup

- 1) Has bin control 1 (Ultrasonic) been set to the proper setting for the application?
- 2) Has bin control 1 (Ultrasonic) operation been confirmed?
- 3) Has bin control 2 (Mechanical Backup) operation been confirmed?
- 4) Are all components, fasteners, and thumbscrews securely in place?
- 5) Has the end user been given the instruction manual, and instructed on how to operate the appliance and the importance of the recommended periodic maintenance?
- 6) Has the end user been given the contact information of an authorized service agent?
- 7) Has the warranty registration been completed and submitted to the factory?

J. Startup

1. Bin Control Setting

An ultrasonic sensor is used as the bin control to control the level of ice in the dispenser unit/ice storage bin. The bin control setting must be set to match the application to avoid possible icemaker movement, water leakage, or ice overflow.

⚠ WARNING

- Improper adjustment may adversely affect safety, performance, component life, and warranty coverage.
- On dispenser unit applications, do not increase ice level above the recommended setting listed below. Higher ice levels could result in icemaker movement, water leakage, or ice overflow.

NOTICE

Do not allow top kits or top kit risers (if applicable) to interfere with the bin control lens sensing area or the icemaker will not operate properly.

- 1) Move the power switch to the "OFF" position. Make sure the power supply is off to the icemaker and condensing unit. Remove the front panel to access the control box assembly. See Fig. 13. Remove the control box cover to access the control board. See Fig. 14.

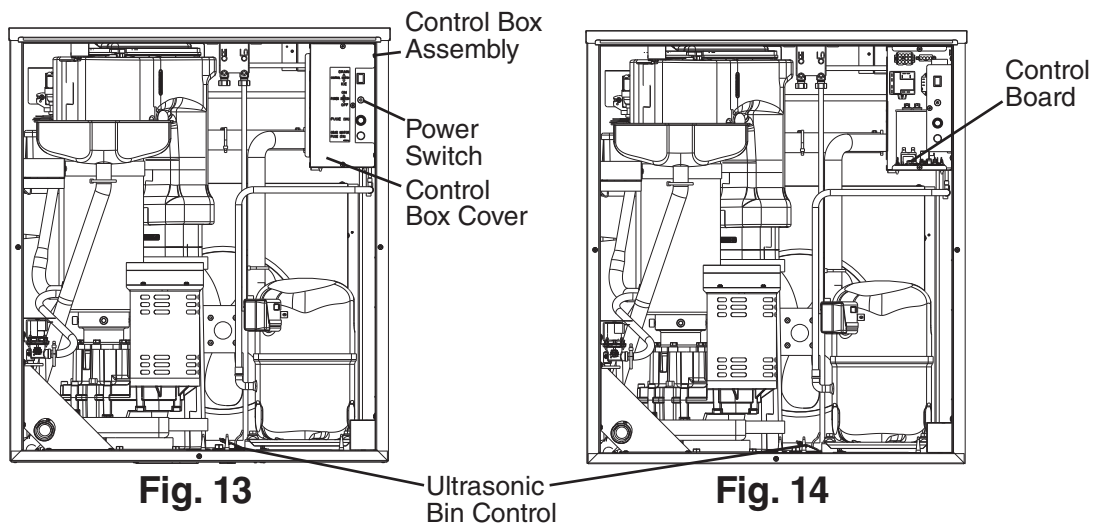

- 2) Confirm the correct control board bin control setting required for your application and adjust according to the following tables. See Fig. 15 and Fig. 16.

For Standard Ice Storage Bins

Application	Bin Control Ice Level Settings	
	Bin Control Setting	Shutdown Distance From Bin Control Lens (Restart is 4" (102 mm) below shutdown distance)
Standard Ice Storage Bins	1 (Factory Default)	127 mm (5") Do not adjust dispensers to this setting.
Optional Setting	4	356 mm (14")
	5	457 mm (18")

⚠ WARNING

Confirm that the final ice level location does not allow for icemaker movement, water leakage, or ice overflow.

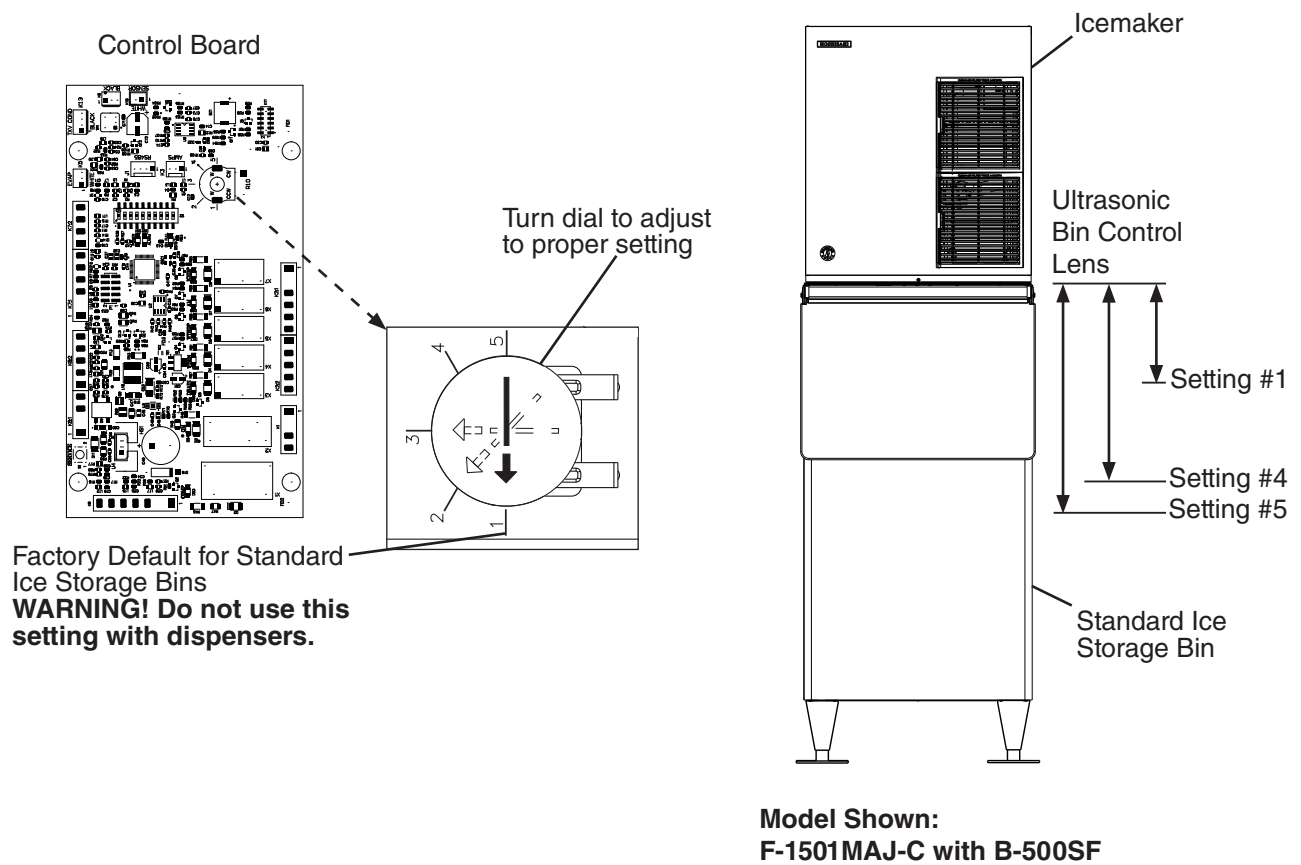

Fig. 15

For Non-Hoshizaki Dispenser Units

Bin Control Ice Level Settings	
Bin Control Setting	Shutdown Distance From Bin Control Lens (Restart is 4 in. (102 mm) below shutdown distance)
1 (Factory Default)	127 mm (5") Do not adjust dispensers to this setting.
2	178 mm (7")
3	254 mm (10")
4	356 mm (14")
5	457 mm (18")

⚠ WARNING

Confirm that the final ice level location does not allow for icemaker movement, water leakage, or ice overflow.

NOTICE

The ice level must be lower than the top of the dispenser unit. Also, be sure the top kit or top kit riser (if applicable) are clear from the bin control lens sensing area.

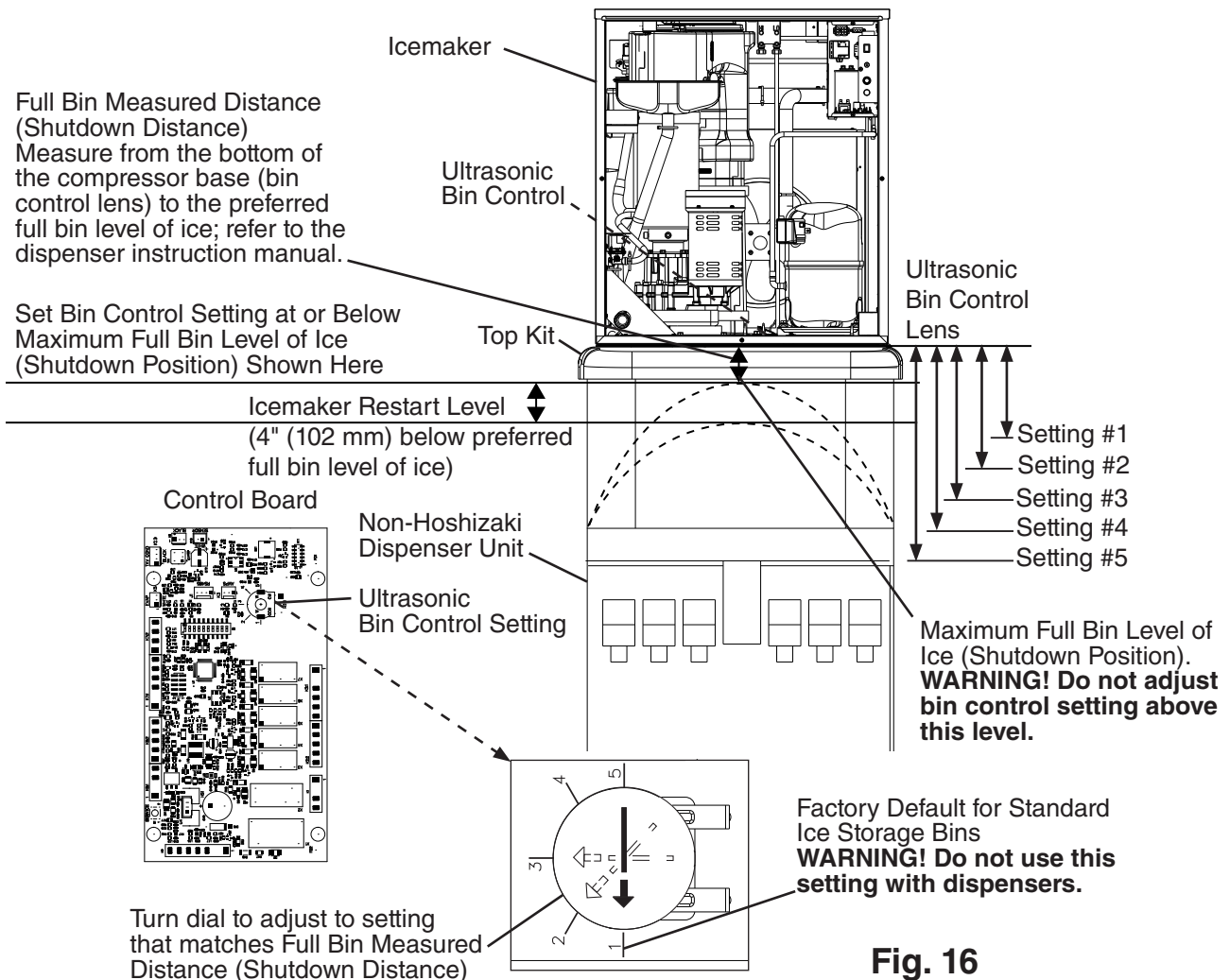

Fig. 16

2. Bin Control Check

An ultrasonic bin sensor is used as the primary bin control to control the level of ice in the dispenser unit/ice storage bin. A mechanical bin control is used as a backup bin control.

a) Bin Control 1 (Ultrasonic)

⚠ WARNING

- All parts are factory-adjusted. Improper adjustments may adversely affect safety, performance, component life, and warranty coverage.
- Make sure the icemaker has been installed as outlined in this manual and that the water supply is on.
- Improper adjustment may adversely affect safety, performance, component life, and warranty coverage.

NOTICE

- If the appliance is turned off, wait for at least 3 minutes before restarting the icemaker to prevent damage to the compressor.
- At startup, confirm that all internal and external connections are free of leaks.
- Do not allow top kits or top kit risers (if applicable) to interfere with the bin control lens sensing area or the icemaker will not operate properly.

Additional Notice for Remote Models

- The appliance must have power for a minimum of 4 hours prior to startup to prevent compressor damage.

- 1) If not already removed, remove the front panel, left side panel, and control box cover.
- 2) Make sure the power switch is in the "OFF" position and that the power supply is off.
- 3) Confirm that control board S2 dip switch 1, 2, and 3 are in the proper position for your application.
- 4) Move the control switch to the "ICE" position, then move the power switch to the "ON" position. Turn on the power supply, and allow the icemaker to operate.
- 5) Confirm the control board orange "BIN FULL" LED is off (bin empty). "POWER LED" is on. See Fig. 17.

Ice Level in Bin	Control Board "BIN FULL" LED
Empty	OFF
Full	ON

- 6) If the control board "BIN FULL" LED is on (indicating a full bin), correct any interference from the top kit or top kit riser (if applicable).

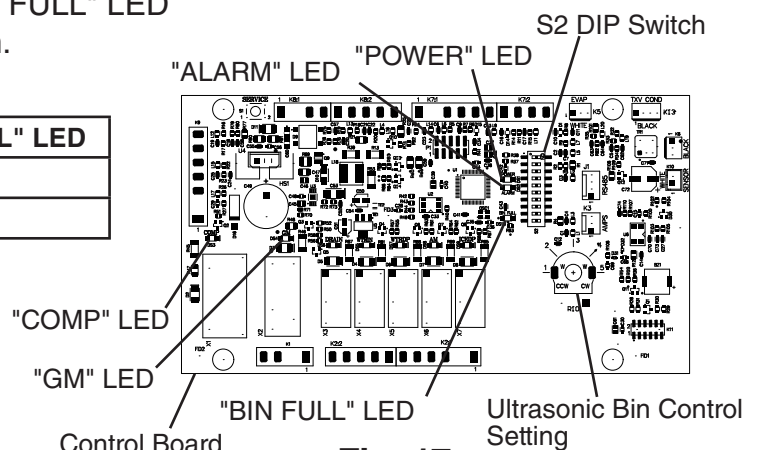

Fig. 17

7) Make sure the "GM" LED is on. See Fig. 13. There is a delay of at least 30 sec. before the "GM" LED turns on after power-up. After "GM" LED turns on, press the "Service" button on the control board to bypass the 5-minute compressor delay. **WARNING! Risk of electric shock. Care should be taken not to touch live terminals.** Confirm the "COMP" LED turns on.

8) "GM" LED and "COMP" LED are on. Place an object 5" to 7" (127 to 178 mm) away from the bin control lens at the bottom of the icemaker. See Fig. 18. If the bottom of the icemaker is not accessible in your application, remove the thumbscrew securing the bin control sensor housing to the base, then remove the bin control sensor housing. See Fig. 19.

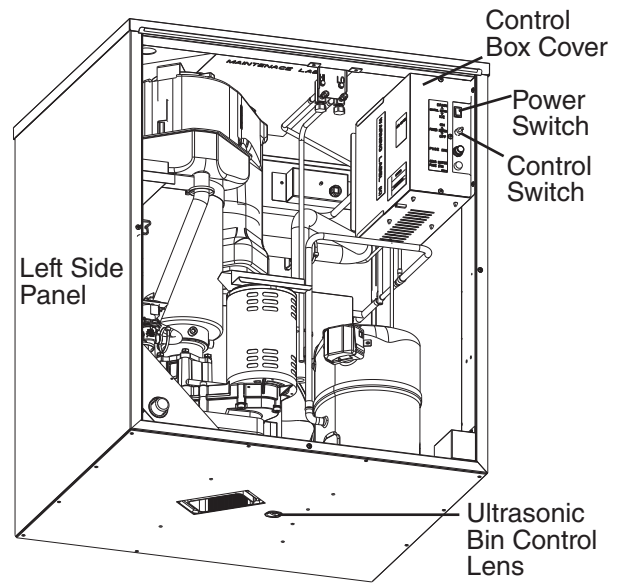

Fig. 18

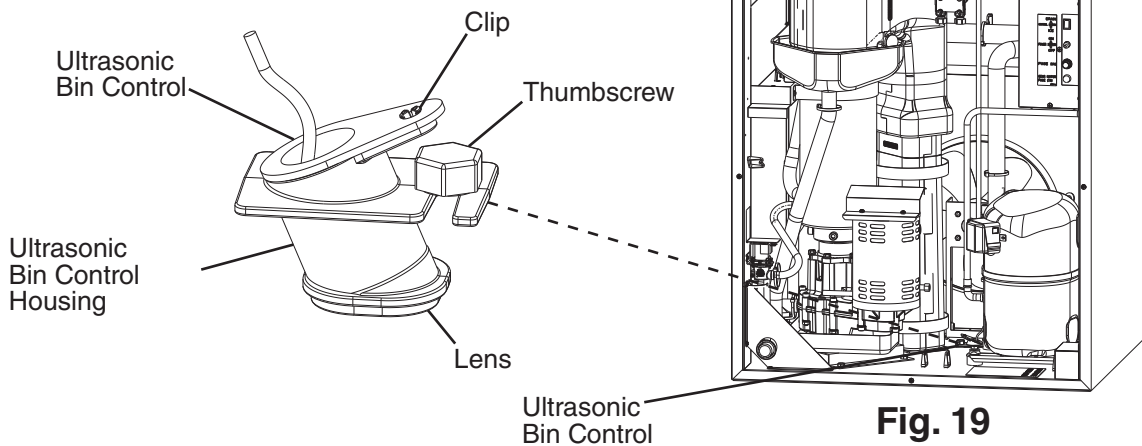

Fig. 19

9) "BIN FULL" LED turns on. 30 sec. later, the "COMP" LED turns off. Approximately 5 min. later, "GM" LED turns off. Remove the object from the bin control lens. Approximately 30 sec. later, orange "BIN FULL" LED turns off, "GM" LED turns on. Approximately 5 min. later, the "COMP" LED turns on.

10) If you removed the Bin Control Sensor from the base, replace it back in its correct position and secure with thumbscrew.

11) Replace the left side panel in its correct position.

12) Move the power switch and control switches to their "OFF" position, then turn off power supply. Proceed to "II.K.2. Bin Control 2 (Mechanical Backup)."

b) Bin Control 2 (Mechanical Backup)

- 1) Make sure the power switch is in the "OFF" position and that the power supply is off.
- 2) If not already removed, remove the front panel, top panel, and control box cover.
- 3) Remove the spout insulation and the spout spring from the spout. See Fig. 20.
- 4) Turn on the power supply. Move the control switch to the "ICE" position, then move the power switch to the "ON" position.
- 5) 30 seconds after the upper float switch closes, the control board "GM" LED turns on. After "GM" LED turns on, press the "SERVICE" button on the control board to bypass the 5-minute compressor delay. **WARNING! Risk of electric shock. Care should be taken not to touch live terminals.**

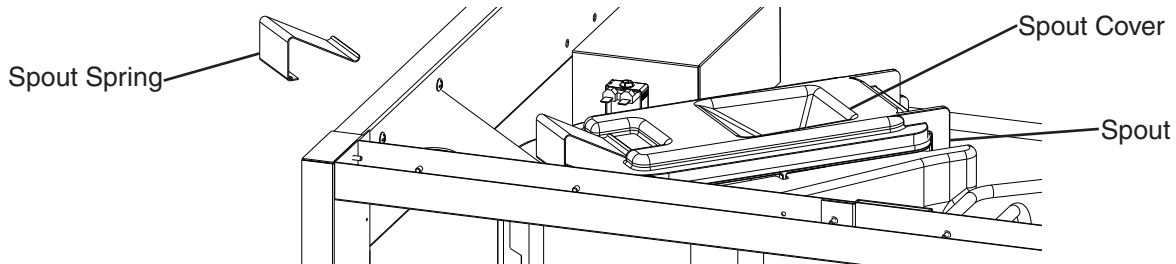

Fig. 20

- 6) "GM" LED and "COMP" LED are on. Open the spout cover slightly. See Fig. 21. "GM" LED and "COMP" LED turn off within 10 seconds and the control board sounds a 9 beep alarm. Close the spout cover.

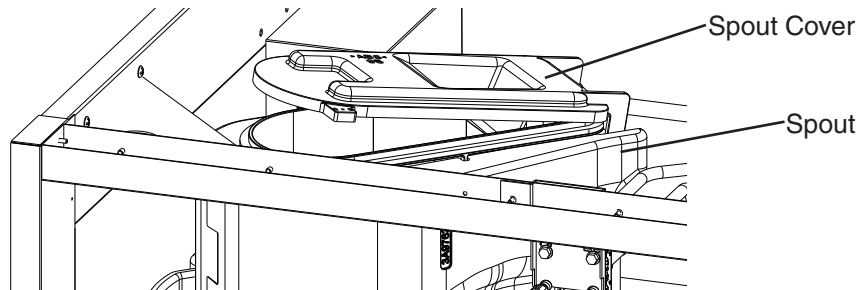

Fig. 21

- 7) Move the power switch to the "OFF" position, then turn off the power supply.
Note: The control board alarm resets when power is turned off.
- 8) Replace the spout spring in its correct position.
- 9) Replace the control box cover and top panel in their correct positions.
- 10) Turn on the power supply. Make sure the control switch is in the "ICE" position, then move the power switch to the "ON" position to start the automatic icemaking process.
- 11) Replace the front panel in its correct position.
- 12) Return to "II.I.2. Post-Startup" and complete final checklist.

K. Alarm Safeties

Should an alarm occur, follow the instructions in the table below to address the alarm. If an alarm continues to occur, contact an authorized service agent.

In case of alarm, the built-in safeties shut down the unit, the orange "ALARM" LED turns on, and audible alarms sound as listed below.

No. of Beeps (every 5 sec.)	Type of Alarm	Notes and Reset Options
1	Low-Water Safety UFS open > 90 sec. after WV energized.	Automatic reset once water supply is restored and UFS closes.
2	Control Switch In "DRAIN" position longer than 15 min.	Automatic reset once the control switch is moved to the "ICE" position.
3	High-Pressure Switch First and second activation in 1 hr.	Automatic reset once pressure drops below the high pressure threshold and the high-pressure switch closes.
4	High-Pressure Switch Third activation in 1 hr.	Turn power off. Call for service. To avoid possible catastrophic failure, it is recommended to leave the icemaker off until this alarm is resolved.
5	Freeze Timer WV off > 30 min. since last WV activation.	Call for service. Manual reset. Turn power off and on again. Check for FS stuck (up), WV leaking by, TXV defective, LLV not opening, low charge, HM not bypassing, or inefficient Comp.
6	Low Voltage 92VAC ± 5% or less.	Green "POWER" LED turns off if voltage protection operates.
7	High Voltage 147VAC ± 5% or more.	Control voltage safeties automatically reset when voltage is corrected.
8	a) Gear Motor Fuse or Protector Open CCR contacts fail to close. Used on all models.	Turn power off. Check for GM fuse or protector open. Replace fuse or let protector cool and reset. If persistent trips occur, call for service.
	b) Evaporator Thermistor At GM startup Evaporator thermistor < -4°F (-20°C). Used on cubelet (-C)(-SC)(-CB) models only.	Turn power off. Call for service. To avoid possible catastrophic failure, it is recommended to leave the icemaker off until this alarm is resolved. Manual reset. Turn power off and on again.
9	Bin Control 2 (Mechanical) Open Circuit Control Board K8 (#3 and #4) Not used on DCM or self-contained models.	Manual reset. Turn power off and on again. Modular Flaker and Cubelet (-C)(-SC)(-CB) Models: Control Board S2 Dip Switch #7 must be ON. DCM and Self-Contained Models: Control Board S2 Dip Switch #7 must be OFF.
10	Evaporator Thermistor Evaporator thermistor reaches -22°F (-30°C) for 3 consecutive cycles. Used on cubelet (-C)(-SC)(-CB) models only.	Turn power off. Call for service. To avoid possible catastrophic failure, it is recommended to leave the icemaker off until this alarm is resolved. Manual reset. Turn power off and on again.

Legend: **Comp**—compressor; **DV**—drain valve; **EH**—evaporator heater; **FM**—fan motor; **FMR**—fan motor-remote; **FS**—float switch; **GM**—gear motor; **HM**—headmaster (C.P.R.); **LLV**—liquid line valve; **SLV**—suction line valve; **TXV**—thermostatic expansion valve; **UFS**—upper float switch; **WV**—inlet water valve

Dip switches are factory set and must be adjusted per the unit's service manual or Hoshizaki Technical Support recommendation.

III. Maintenance

The appliance must be maintained in accordance with the instruction manual and labels provided. Consult with your local Hoshizaki Certified Service Representative about maintenance service. To obtain the name and phone number of your local Hoshizaki Certified Service Representative, visit www.hoshizakiamerica.com.

⚠ WARNING

- Only qualified service technicians should service the appliance.
- To reduce the risk of electric shock, do not touch the icemaker power switch or control switch with damp hands.
- **Before Servicing:** Move the icemaker's power switch to the "OFF" position. Turn off the power supply. Place the disconnect (if applicable) in the off position. Lockout/Tagout to prevent the power supply from being turned back on inadvertently.
- **CHOKING HAZARD:** Ensure all components, fasteners, and thumbscrews are securely in place after any maintenance is done to the appliance. Make sure that none have fallen into the dispenser unit/ice storage bin.

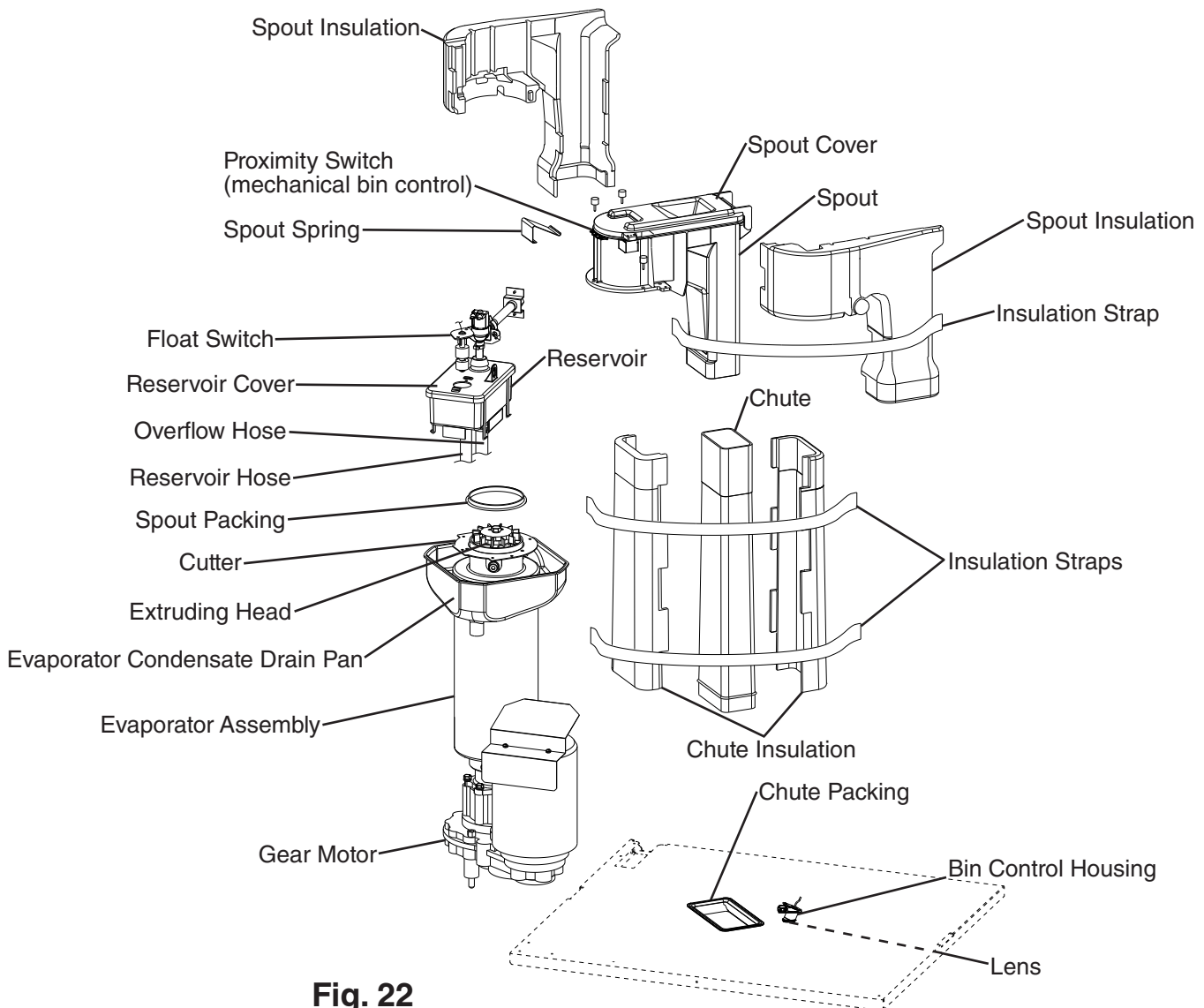

Fig. 22

A. Maintenance Schedule

The maintenance schedule below is a guideline. More frequent maintenance may be required depending on water quality, the appliance's environment, and local sanitation regulations.

Maintenance Schedule		
Frequency	Area	Task
Daily	Scoop	Clean the ice scoop using a neutral cleaner. Rinse thoroughly after cleaning.
Bi-Weekly	Air Filters	Inspect. Wash with warm water and neutral cleaner if dirty.
Monthly	External Water Filters	Check for proper pressure and change if necessary.
	Icemaker Exterior	Wipe down with a clean, soft cloth. Use a damp cloth containing a neutral cleaner to wipe off oil or dirt build up. Clean any chlorine staining (rust colored spots) using a non-abrasive cleanser.
	Bin Control Lens	Wipe down the bin control lens, (located on the bottom of the icemaker) with a neutral cleaner. Rinse thoroughly after cleaning.
	Underside of Icemaker and Top Kits; Bin Door and Snout	Wipe down with a clean cloth and warm water.
Every 6 Months	Icemaker and Dispenser Unit/Ice Storage Bin	Clean and sanitize per the cleaning and sanitizing instructions provided in this manual.
	Evaporator Condensate Drain Pan and Gear Motor Drain Pan	Wipe down with a clean cloth and warm water. Slowly pour one cup of sanitizing solution (prepare as outlined in the sanitizing instructions in this manual) into the evaporator condensate drain pan and then slowly pour one cup into the gear motor drain pan. Be careful not to overflow the pans. Repeat with a cup of clean water to rinse.
	Icemaker and Dispenser Unit/Ice Storage Bin Drains	Check to make sure they are clear.
	Extruding Head Seal Bolts	Inspect for leakage around seal bolts. Tighten (see torque values below) or replace as necessary. Seal bolts must be replaced once removed because seal material is one-time use only. If new seal bolts do not have preapplied threadlocker, apply Loctite 243 or equivalent threadlocker to seal bolt threads. <ul style="list-style-type: none"> • <i>Torque for F-1501 and Larger: 25.8 ft-lb/35 N-m</i> Tighten 2 times. Allow at least 5 sec. in between each tightening.
Yearly	Inlet Water Valve and Drain Valve	Close the water supply line shut-off valve and drain the water system. Clean the inlet water valve screen and clean and inspect the drain valve.
	Water Hoses	Inspect the water hoses and clean/replace if necessary.
	Condenser	Inspect. Clean if necessary by using a brush or vacuum cleaner.
	Icemaker	Inspect for oil spots, loose components, fasteners, and wires
	Upper Bearing (extruding head)	Check for wear using .02" round stock or pin gauge. Replace both upper bearing and lower bearing if wear exceeds factory recommendations. See the Service Manual for details.
After 3 Years, then Yearly	Upper Bearing (extruding head); Lower Bearing and O-Ring (lower housing); Mechanical Seal; Evaporator Cylinder; Auger	Inspect. Replace both upper bearing and lower bearing if wear exceeds factory recommendations. Replace the mechanical seal if the seal's contact surfaces are worn, cracked, or scratched. See the Service Manual for details.

B. Cleaning and Sanitizing Instructions

The appliance must be cleaned and sanitized at least twice a year. More frequent cleaning and sanitizing may be required in some conditions.

WARNING

- To prevent injury to individuals and damage to the appliance, do not use ammonia type cleaners.
- Carefully follow any instructions provided with the cleaning and sanitizing solutions.
- Always wear liquid-proof gloves and goggles to prevent the cleaning and sanitizing solutions from coming into contact with skin or eyes.
- After cleaning and sanitizing, do not use ice made from the cleaning and sanitizing solutions. Be careful not to leave any solution on the parts or in the dispenser unit/ice storage bin.

1. Cleaning Solution

Dilute 9.6 fl. oz. (0.29 l) of Hoshizaki "Scale Away" with 1.6 gal. (6.0 l) of warm water. This is a minimum amount. Make more solution if necessary. **IMPORTANT! For safety and maximum effectiveness, use the solution immediately after dilution.**

2. Cleaning Procedure

- 1) Close the icemaker water supply line shut-off valve.
- 2) Turn off the power supply, then remove the front panel. Make sure the power switch is in the "ON" position, then move the control switch to the "DRAIN" position. Replace the front panel in its correct position.
- 3) Turn on the power supply and allow the water system to drain completely.
- 4) Turn off the power supply, then remove the front and top panels. Move the power switch to the "OFF" position.
- 5) Remove all of the ice from the dispenser unit/ice storage bin. WARNING! If on a dispenser unit, turn off the dispenser unit power supply after dispensing the ice.
- 6) Remove the spout spring, then open the spout cover. See Fig. 22.
- 7) Pour the cleaning solution over the extruding head until the evaporator assembly and the reservoir are full and the solution starts to run through the overflow hose on the reservoir.
Note: If there is excess scale on the extruding head, fill the evaporator assembly and reservoir as described above, then use a clamp on the reservoir hose between the reservoir and evaporator assembly to block flow. Pour additional cleaning solution over the extruding head until the evaporator assembly is completely full.
- 8) Close the spout cover and replace the spout spring in its correct position.
- 9) Allow the icemaker to sit for 10 minutes before operation. If you placed a clamp on the reservoir hose in step 7, remove it before operation.

- 10) In bad or severe water conditions, clean the float switch as described below.
Otherwise, continue to step 11.
 - a. Remove the float switch from the reservoir cover.
 - b. Wipe down the float switch with the cleaning solution.
 - c. Rinse the float switch thoroughly with clean water.
 - d. Replace the float switch in its correct position.
- 11) Wipe down the bin control lens, (located on the bottom of the icemaker) with the cleaning solution. Next, rinse the cleaning solution off of the bin control lens with a clean, damp cloth.
Note: If the bottom of the icemaker is not accessible in your application, remove the thumbscrew securing the bin control housing, then remove the housing from the base. After cleaning and rinsing the lens, replace the housing in its correct position and secure it with the thumbscrew.
- 12) Move the control switch to the "ICE" position, then move the power switch to the "ON" position. Replace the panels in their correct positions. Turn on the power supply and make ice using the solution until the icemaker stops making ice.
- 13) Turn off the power supply, then remove the front panel. Move the control switch to the "DRAIN" position, then replace the front panel in its correct position.
- 14) Turn on the power supply and allow the water system to drain completely.
- 15) Turn off the power supply, then remove the front panel. Move the control switch to the "ICE" position, then replace the front panel in its correct position.
- 16) Open the icemaker water supply line shut-off valve, then turn on the power supply to supply water to the reservoir.
- 17) After the gear motor starts, turn off the power supply. Remove the front panel, then move the control switch to the "DRAIN" position. Replace the front panel in its correct position.
- 18) Turn on the power supply and allow the water system to drain completely.
Note: If you do not sanitize the unit, go to step 14 in "III.B.5. Sanitizing Procedure - Final."
- 19) Turn off the power supply, then close the icemaker water supply line shut-off valve.

3. Sanitizing Solution

Dilute 2.5 fl. oz. (74 ml or 5 tbs) of a 7.5% sodium hypochlorite solution (chlorine bleach) with 5 gal. (19 l) of warm water. This is a minimum amount. Make more solution if necessary. **IMPORTANT! For safety and maximum effectiveness, use the solution immediately after dilution.**

4. Sanitizing Procedure - Initial

- 1) Make sure the power supply is off and the icemaker water supply line shut-off valve is closed. Remove the front and top panels, then move the power switch to the "OFF" position.
- 2) Remove the spout spring, then open the spout cover. See Fig. 21. Next, remove the proximity switch from the spout assembly, then remove the spout and chute assembly, and spout packing from the icemaker.
- 3) Pour the sanitizing solution over the extruding head until the evaporator assembly and the reservoir are full and the solution starts to run through the overflow hose on the reservoir.
- 4) Remove the spout and chute insulation straps, then remove the spout and chute insulation and set aside.
- 5) Soak the spout assembly, chute, and spout packing in the sanitizing solution for 10 minutes then wipe them down. Next, wipe down the chute packing at the base of the icemaker.
- 6) Rinse the parts thoroughly with clean water.
- 7) Replace the spout packing, chute, spout assembly, insulation, and insulation straps in their correct positions. Next, open the spout cover and replace the proximity switch in its correct position, then close the spout cover and replace the spout spring in its correct position. **IMPORTANT! Be sure the insulation is placed back in its correct position and secured with the insulation straps.**
- 8) Move the control switch to the "ICE" position, then move the power switch to the "ON" position. Replace the panels in their correct positions, then turn on the power supply. Make ice using the solution until the icemaker stops making ice.
- 9) Turn off the power supply, then remove the front panel. Move the control switch to the "DRAIN" position, then replace the front panel in its correct position.
- 10) Turn on the power supply and allow the water system to drain completely.
- 11) Turn off the power supply.

5. Sanitizing Procedure - Final

- 1) Dilute 2.5 fl. oz. (74 ml or 5 tbs) of a 7.5% sodium hypochlorite solution (chlorine bleach) with 5 gal. (19 l) of warm water. This is a minimum amount. Make more solution if necessary. **IMPORTANT! For safety and maximum effectiveness, use the solution immediately after dilution.**
- 2) Make sure the power supply is off and the icemaker water supply line shut-off valve is closed. Remove the front and top panels, then move the power switch to the "OFF" position.
- 3) Remove the spout spring and open the spout cover.
- 4) Pour the sanitizing solution over the extruding head until the evaporator assembly and the reservoir are full and the solution starts to run through the overflow hose on the reservoir.
- 5) Close the spout cover, then replace the spout spring in its correct position.
- 6) Allow the icemaker to sit for 10 minutes before operation.
- 7) Move the control switch to the "ICE" position, then move the power switch to the "ON" position. Replace the panels in their correct positions, then turn on the power supply. Make ice using the solution until the icemaker stops making ice.
- 8) Turn off the power supply, then remove the front panel. Move the control switch to the "DRAIN" position, then replace the front panel in its correct position.
- 9) Turn on the power supply and allow the water system to drain completely.
- 10) Turn off the power supply, then remove the front panel. Move the control switch to the "ICE" position, then replace the front panel in its correct position.
- 11) Open the icemaker water supply line shut-off valve, then turn on the power supply to supply water to the reservoir.
- 12) After the gear motor starts, turn off the power supply. Remove the front panel, then move the control switch to the "DRAIN" position. Replace the front panel in its correct position.
- 13) Turn on the power supply and allow the water system to drain completely.
- 14) Turn off the power supply, then remove the front panel. Move the control switch to the "ICE" position, then replace the front panel in its correct position.
- 15) Turn on the power supply to start the automatic icemaking process. Allow the icemaker to run for 30 minutes, then turn off the power supply.
- 16) Pour warm water into the dispenser unit/ice storage bin and melt any remaining ice. Clean the dispenser unit/ice storage bin liner using a neutral cleaner. Rinse thoroughly after cleaning.
- 17) Turn on the power supply to start the automatic icemaking process.
Note: If on a dispenser unit, turn on the dispenser unit power supply.

IV. Preparing the Appliance for Periods of Non-Use

NOTICE

When storing the appliance for an extended time or in sub-freezing temperatures, follow the instructions below to prevent damage.

When the appliance is not used for two or three days under normal conditions, it is sufficient to only move the power switch to the "OFF" position. When storing the appliance for extended time or in sub-freezing temperatures, follow the instructions below.

1. Remove the water from the icemaker water supply line:

- 1) Turn off the power supply, then remove the front panel.
- 2) Move the power switch to the "OFF" position.
- 3) Close the icemaker water supply line shut-off valve, then open the icemaker water supply line drain valve.
- 4) Allow the line to drain by gravity.
- 5) Attach a compressed air or carbon dioxide supply to the icemaker water supply line drain valve.
- 6) Move the control switch to the "ICE" position, then move the power switch to the "ON" position. Replace the front panel in its correct position, then turn on the power supply.
- 7) Blow the icemaker water line out using the compressed air or carbon dioxide supply.
- 8) Close the icemaker water supply line drain valve.

2. Drain the evaporator:

- 1) Turn off the power supply, then remove the front panel.
- 2) Move the control switch to the "DRAIN" position, then replace the front panel in its correct position.
- 3) Turn on the power supply and allow the water system to drain for 5 minutes.
- 4) Turn off the power supply, then remove the front panel. Move the power switch to the "OFF" position.
- 5) Remove the evaporator drain line hose from the evaporator and attach a compressed air or carbon dioxide supply to the hose.
- 6) Turn on the power supply, then move the power switch to the "ON" position. Blow out the evaporator drain line using the compressed air or carbon dioxide supply until water stops coming out.
- 7) Move the power switch to the "OFF" position, then turn off the power supply. Reconnect the evaporator drain line hose.
- 8) Move the control switch to the "ICE" position. Replace the front panel in its correct position.
- 9) Remove all ice from the dispenser unit/ice storage bin. Clean the dispenser unit/ice storage bin liner using a neutral cleaner. Rinse thoroughly after cleaning.

3. On water-cooled models, remove the water from the water-cooled condenser:

- 1) Make sure the power supply is off, then remove the front panel and right side panel.
- 2) Close the condenser water supply line shut-off valve. If connected to a closed loop system, also close the condenser return line shut-off valve.
- 3) Open the condenser water supply line drain valve. If connected to a closed loop system, also open the condenser return line drain valve.
- 4) Attach a compressed air or carbon dioxide supply to the condenser water supply line drain valve.
- 5) Open the water regulating valve by using a screwdriver to pry up on the spring retainer underneath the spring. While holding the valve open, blow out the condenser using the compressed air or carbon dioxide supply until water stops coming out.
- 6) Close the drain valve(s).
- 7) Replace the right side panel and front panel in their correct positions.

V. Disposal

The appliance contains refrigerant and must be disposed of in accordance with applicable national, state, and local codes and regulations. Refrigerant must be recovered by properly certified service personnel.

HOSHIZAKI AMERICA, INC.

618 Hwy. 74 South, Peachtree City, GA 30269 USA (P) 770.487.2331 (F) 770.487.3360 hoshizakiamerica.com 1A7206-010