





ASSEMBLY INSTRUCTION FOR ACME FURNITURE





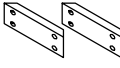

MODEL#DN03656

Thank you for purchasing the quality product. Be sure to check all packing material carefully for small parts which may have come loose inside the carton during shipment. Separate, identify and count all parts and metal hardware. Compare with all parts list to be sure all parts are present. If any part(s) are missing or damaged, please contact your local furniture dealer. For efficient and speedy service, please indicate the model the model number and code letter of part(s) needed.

***** Do not fully tighten screw until fully assembled *****

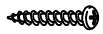
COMPONENT PARTS			
DESCRIPTION	PART NAME		QTY (PCS)
①	BACK REST		1
②	BACK REST VENEER		1
③	LEG (L & R)		2
④	CORNER BLOCK		2
⑤	CUSHION SEAT		1

HARDWARE REQUIRED

(A)		JCBC BOLT M6 x 45MM	4 PCS
(B)		SPRING WASHER 1/4"	4 PCS
(C)		WOOD BUTTON (DIA : 14.5 x 9mm)	4 PCS
(D)		PAN HEAD WOOD SCREW M5 X 32MM	14 PCS
(E)		WOOD DOWEL DIA 10 x 30MM	2 PCS
(F)		M4 ALLEN KEY (BALL SHAPE) LONG	1 PC
(G)		ADJUSTABLE SCREW	2 PCS

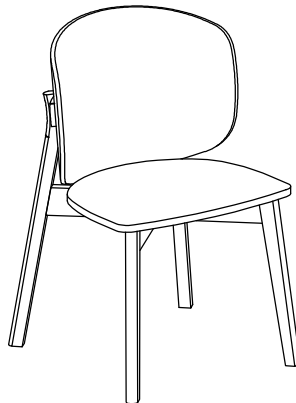

Attention

*** Some number parts listed on the instruction sheet may not be in parts bag as may already be assembled. Carefully check parts and packing materials prior to ordering replacements.

How to assemble:

STEP 1

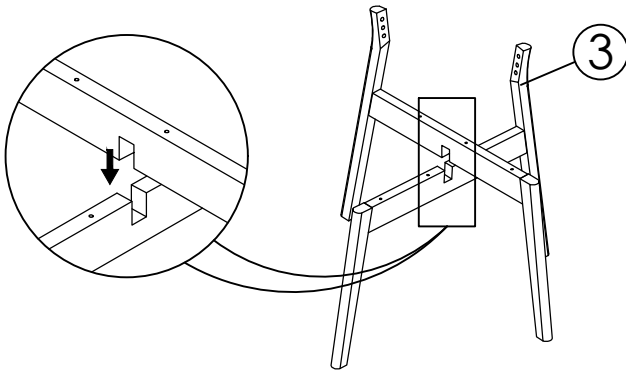
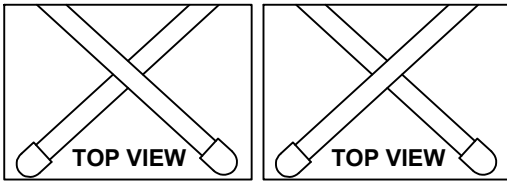

STEP 2

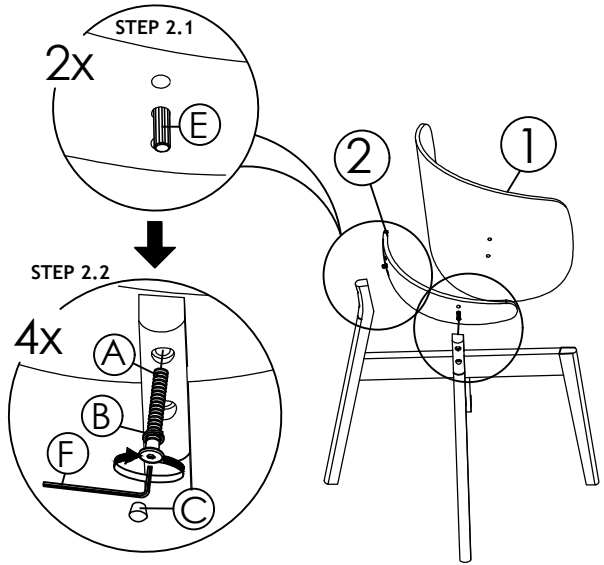

STEP 3

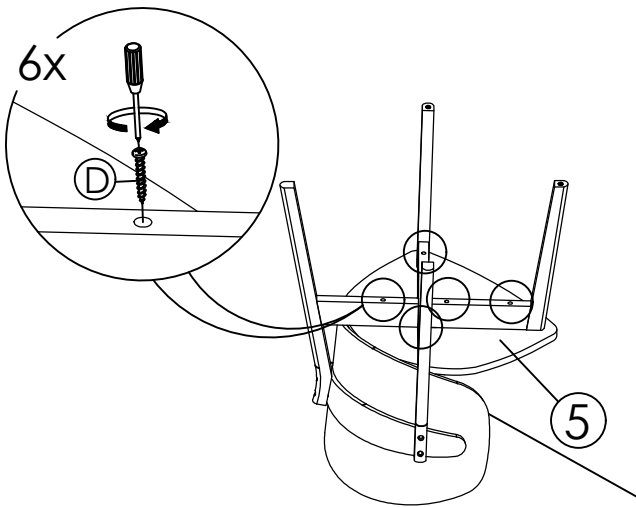

STEP 4

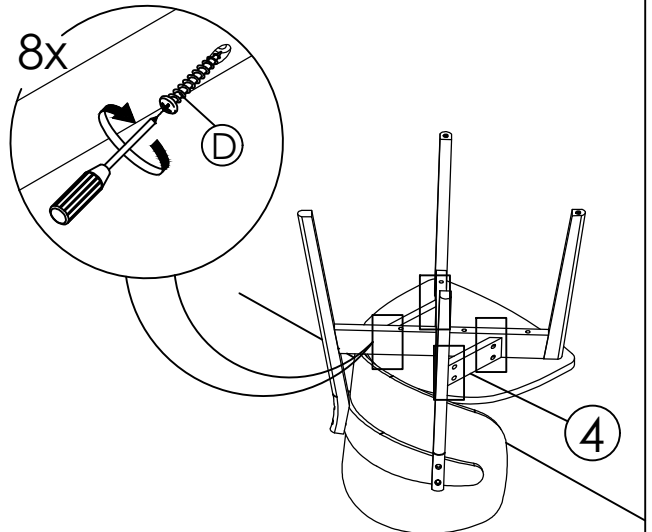

STEP 5

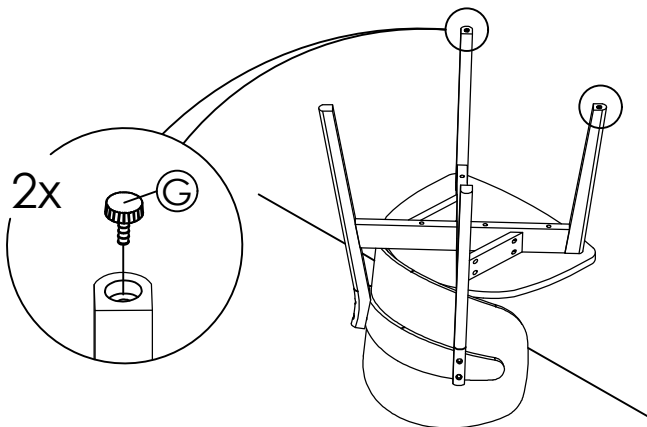

STEP 6

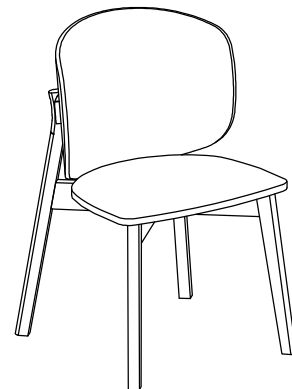

ASSEMBLY COMPLETED