

elica

EWC18SRN683PR EWC18SRN683PR-L EWC24SRN103PR

Wine Column User Manual

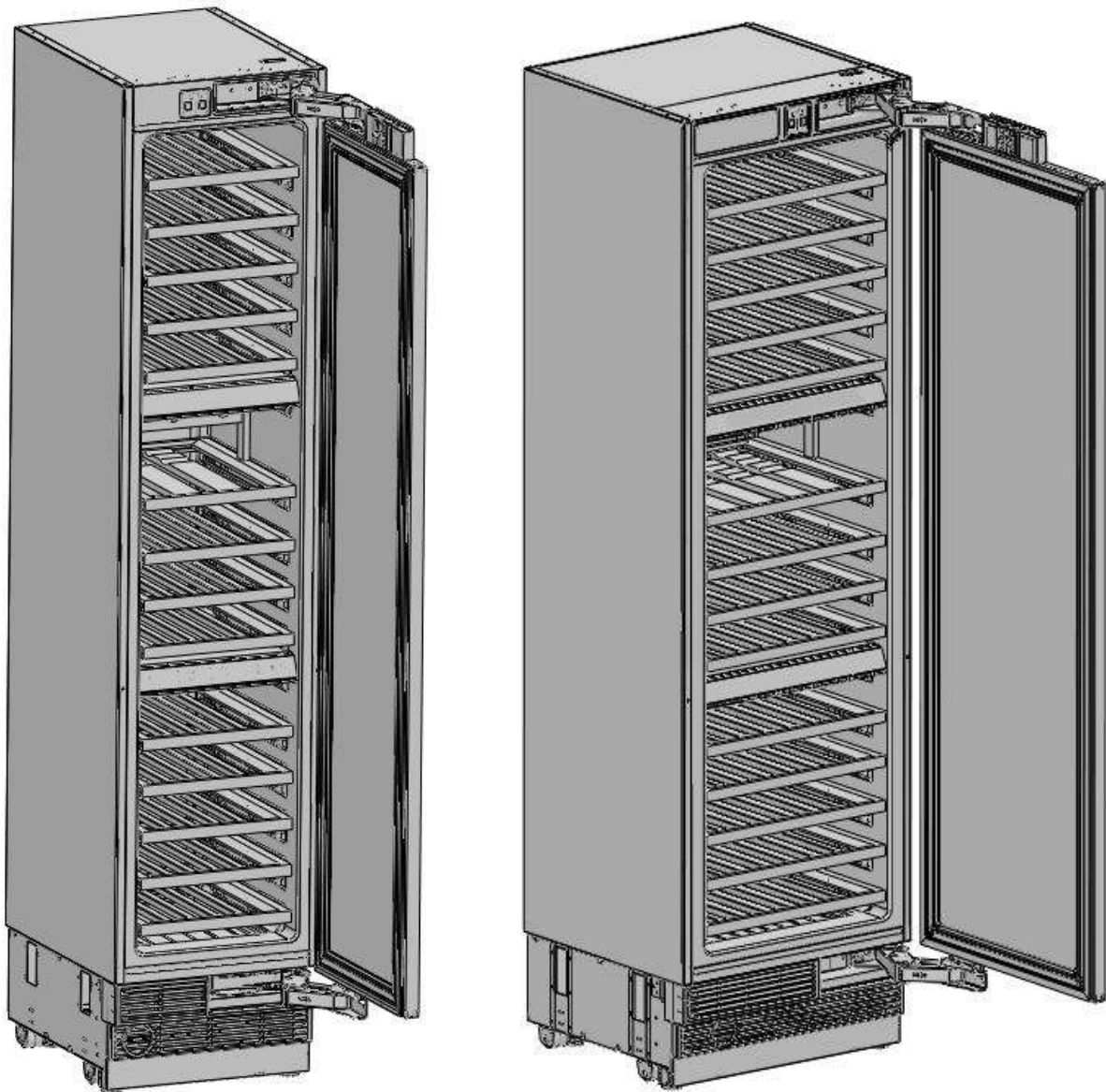

Contents

	Page
Safety Information.....	3-10
Types of Safety Warnings.....	3
General Safety.....	4-6
Save These Instructions.....	7
Disposal of Old Appliance.....	7
Before Using Your Appliance.....	8
Installation of Your Appliance.....	8-9
Attention.....	9
Electrical Connection.....	10
Introduction.....	12
List of Materials.....	13
Product Specifications.....	13-17
Internal Storage.....	13-16
Parts Identification.....	17
Installation Instructions.....	18-46
Installation dimensions.....	18-20
Electrical location.....	21
Carbon Filter.....	22
Installing the Handle.....	22
Changing the door opening direction.....	23-28
Removing the packing.....	27-31
Removing the vent hole assembly.....	31
Mounting the anti-tip brackets.....	32
Installation Instructions.....	33-44
Installing the limit pins.....	45
Removing the Wooden Shelves.....	46
Operating Your Appliance.....	47-50
Care And Maintenance.....	50-52
Troubleshooting.....	53-54

Safety Information

Your safety and the safety of others are very important. We have provided many important safety

messages in this manual for your appliance. Always read and obey all safety messages.



This is the Safety Alert Symbol. This symbol alerts you to potential hazards that can cause severe bodily injury or death.



All safety messages will follow the Safety Alert Symbol and either the words "DANGER"

"WARNING" OR "CAUTION"

	DANGER
Danger means that failure to heed this safety statement may result in severe injury or death.	
	WARNING
Warning means that failure to heed this safety statement may result in extensive product damage, serious personal injury, or death.	
	CAUTION
Caution means that failure to heed this safety statement may result in minor or moderate personal injury, property or equipment damage.	

Safety Information

General Safety

	DANGER
When using an electrical appliance, basic precautions should always be followed to reduce the risk of fire, electric shock, and injury to persons.	
	WARNING
To reduce the risk of fire, electric shock or personal injury, unplug or disconnect the appliance from the power supply before servicing.	
	CAUTION
Flammable refrigerant used! When handling, moving and use of the refrigerator, make sure to avoid either damaging the refrigerant tubing, or increasing the risk of a leak.	

- ▶ Use this appliance only as described in this manual. Other uses not recommended may cause fire, electric shock or personal injury.
- ▶ This appliance is not intended for use by young children or infirm persons unless they have been adequately supervised by a responsible person to ensure that they can use the appliance safely.
- ▶ Young children should be supervised to ensure that they never play with the appliance.
- ▶ To protect against the risk of electric shock, NEVER IMMERSE the unit, cord, or plug in water or spray any other liquid.
- ▶ Unplug the appliance from the plug socket when not in use, when moving from one location to another and before cleaning.

Safety Information

For your safety, read all instructions carefully before operating the appliance.

- ▶ To disconnect the appliance, grip the plug and pull it from the wall outlet. Never pull by the cord.
- ▶ Never operate the appliance in the presence of explosive and/or Flammable fumes.
- ▶ Never place the appliance or any of its parts near an open flame, cooking or other heating appliance.
- ▶ Never operate the appliance with a damaged cord or plug, if the product malfunctions, or if it is dropped or damaged in any manner.
- ▶ The use of attachments not recommended by the manufacturer may be hazardous.
- ▶ Never operate if the housing is removed or damaged.
- ▶ A loose fit between the AC outlet (receptacle) and plug may cause overheating and a distortion of the plug. Contact a Qualified electrician to replace loose or worn outlet.



WARNING

Prop. 65 Warning for California Residents: This product may contain chemicals known to the State of California to cause cancer, birth defects, or other reproductive harm.

- ▶ Locate the unit away from direct sunlight and sources of heat (stove, heater, radiator, etc.).
- ▶ This appliance is CFC and HFC free and contains small quantities of isobutane (R600a), an environmentally friendly coolant.
- ▶ CAUTION – Risk of fire or explosion due to puncture of refrigerant tubing; follow handling instructions carefully. Flammable refrigerant used.
- ▶ You must ensure that the cooling circuit is undamaged when installing the appliance. However, if it becomes damaged, avoid proximity to open fires and heat sources of all kinds. The room in which the appliance is located should be ventilated properly and according to state and local codes.
- ▶ Never use an appliance with a damaged circuit.
- ▶ Ensure that the ventilation openings to and from a built-in appliance are never blocked or covered.
- ▶ No liability will be accepted for any damage caused by misuse of the appliance, or as a result of repairs carried out by unqualified person. In this case neither the warranty nor any other liability claims will apply.

Safety Information



WARNING

Never operate any other electrical appliance inside this appliance.

- ▶ Never attempt to repair or replace any part of your appliance unless it is specifically recommended in this manual. All other servicing should be referred to a qualified technician.
- ▶ DANGER – Risk of fire or explosion. Flammable refrigerant used. To be repaired only by trained service personnel. Use only manufacturer authorized service parts. Any repair equipment used must be designed for flammable refrigerants. Follow all manufacturer repair instructions. Do not puncture refrigerant tubing.
- ▶ DANGER – Risk of fire or explosion. Flammable refrigerant used. Do not use mechanical devices to defrost refrigerator. Do not puncture refrigerant tubing.
- ▶ Replace all access panels before operating.
- ▶ Use two or more people to move and install the appliance. Failure to do so can result in back or other injury.
- ▶ Never clean appliance parts with flammable liquids. These fumes can create a fire hazard or explosion. Never store or use gasoline or other flammable vapors and liquids in the vicinity of this or any other appliance. The fumes can create a fire hazard or explosion.
- ▶ Never connect or disconnect the electric plug with wet hands.
- ▶ It is recommended that a separate circuit, serving only your appliance be provided. Use receptacles that cannot be turned off by a switch or pull chain.



WARNING

To reduce the risk of fire, electric shock or personal injury, unplug or disconnect the appliance from the power supply before servicing.

Safety Information

For your safety, read all instructions carefully before operating the appliance.

Save These Instructions

If you are experiencing problems, check the Troubleshooting Guide at the back of this manual. It lists causes of minor operating problems that you can correct yourself.

Disposal of Old Appliance

Dispose of your appliance packaging properly. Refrigeration equipment must be properly disposed of in a way which protects the environment. This applies to your old appliance and to your new unit once it has reached the end of its service life.



- ▶ **WARNING:** Risk of child entrapment. Before you throw away your old refrigerator or freezer, Take off the doors. Leave the shelves in place so that children may not easily climb inside.
- ▶ **CAUTION –** Risk of fire or explosion. Dispose of refrigerator properly in accordance with the applicable federal or local regulations. Flammable refrigerant used.
- ▶ The appliance must not be disposed with normal household waste collection.
- ▶ The coolant circuit, particularly the heat exchange at the back/bottom of the unit, must not be damaged.
- ▶ The symbol on the product or its packaging indicates that this product is not to be handled as normal household waste but is to be taken to a recycling collection point for electrical and electronic goods. By correctly disposing of this product you are contributing to the protection of the environment. Improper disposal endangers health and the environment. Further information about the recycling of the product may be obtained from your town hall or local waste collection department.

Safety Information

Before Using Your Appliance

- ▶ Remove all exterior and interior packing.
- ▶ Before connecting the appliance to the power source, let it stand upright for approximately 2 hours. This will reduce the possibility of a malfunction in the cooling system caused by handling during transportation.
- ▶ Clean the interior surface with warm water using a soft cloth.
- ▶ The door on this appliance can be opened from either the left or the right side. The unit is delivered with the door opening on the left side. Should you wish to open the door from the right, follow the instructions, "Reversing the Door Swing of your Appliance," listed below.

Installation of Your Appliance

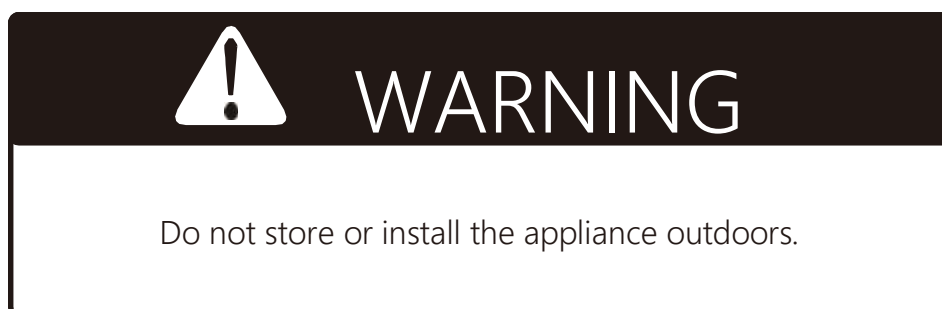

- ▶ The appliances are designed for either built-in, or free-standing installation.
- ▶ Place your appliance on a **f**loor that is strong enough to support it when it is fully loaded. To level your appliance, adjust the 4 legs until level.
- ▶ Locate the appliance away from direct sunlight and sources of heat (stove, heater, radiator, etc.). Direct sunlight may **a**ffect the acrylic coating and heat sources may increase electrical consumption. Extreme cold ambient temperatures may also cause the unit not to perform properly.
- ▶ Never place the unit in damp areas.
- ▶ Plug the appliance into an exclusive, easily accessible electrical socket.
- ▶ Any questions concerning power and/or electrical connection should be directed towards a qualified electrician or an authorized products service center.
- ▶ The air vent at the front of the appliance must never be covered or blocked in any way.

Safety Information

For your safety, read all instructions carefully before operating the appliance.

- ▶ The appliance must be installed to all electrical connections in accordance with state and local codes.
- ▶ Use two or more people to move and install the beverage cooler. Failure to do so can result in back or other injury.
- ▶ The cooler may experience decreased cooling efficiency if air flow is restricted due to a fully loaded cabinet.
- ▶ Install the beverage cooler in a well-ventilated area where the ambient temperature is above 50°F and below 90°F.

Attention

- ▶ Never overload the cabinet.
- ▶ Never open the door unless necessary.
- ▶ Never cover shelves with aluminum foil or any other shelf material which may prevent air circulation.
- ▶ Should the appliance be left empty for long periods, it is suggested that the appliance be unplugged, and, after careful cleaning, leave the door ajar to allow air to circulate inside the cabinet in order to avoid possible condensation, mold or odors from forming.

Safety Information

Electrical Connection

Check that the voltage marked on the product corresponds with your supply voltage.

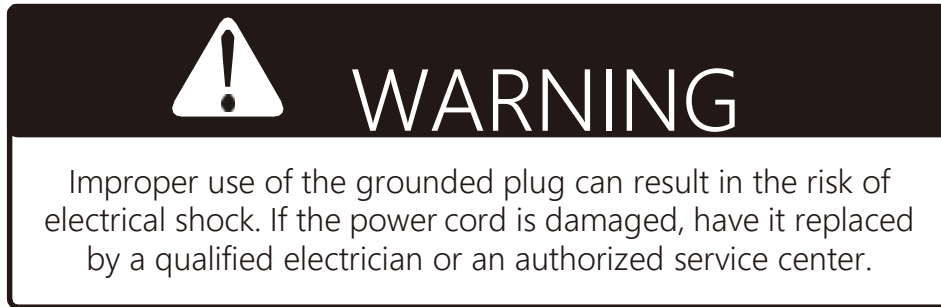

This appliance should be properly grounded for your safety. The power cord of this appliance is equipped with a three-pin plug which mates with standard three-pin wall outlets to minimize the possibility of electrical shock.

Never under any circumstances cut or remove the third ground prong from the power cord supplied. For personal safety, this appliance must be properly grounded.

Have the wall outlet and circuit checked by a qualified electrician to make sure the outlet is properly grounded. When a standard two-pin wall outlet is encountered, it is your responsibility and obligation to have it replaced with a properly grounded three-pin wall outlet.

To prevent accidental injury, the cord should be secured behind the appliance and not left exposed or dangling.

The appliance should always be plugged into its own individual electrical outlet which has a voltage rating that matches the rating label on the appliance. This provides the best performance and also prevent overloading wiring circuits that could cause a fire hazard from overheating. Never unplug the appliance by pulling the power cord. Always grip the plug firmly and pull straight out from the receptacle. Repair or replace immediately all power cords that have become frayed or otherwise damaged. Never use a cord that shows cracks or abrasion damage along its length or at either end. When moving the appliance, be careful not to damage the power cord.

Never use your appliance with an extension cord unless this cord has been checked and tested by a qualified technician or service person. The extension cord must be a UL/CUL Listed, 3-wire grounding extension cord that has a grounding plug and outlet and that the electrical rating of the cord is 115 volts and at least 10 amperes.

Introduction

Thank you for purchasing your beverage cooler.

This manual contains important information regarding the proper installation, use, and maintenance of your beverage cooler. Following this manual will ensure that your product will work at its peak performance and efficiency.

For Your Records

Please write down the model number and serial number below for future reference. Both numbers are located on the rating label on the back of your unit or inside of the unit and are needed to obtain warranty service. You may also want to staple your receipt to this manual as it is the proof of your purchase and may also be needed for service under warranty.

Model Number:

Serial Number:

















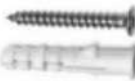

Date of Purchase:

To better serve you, please do the following before contacting customer service:

If you received a damaged product, immediately contact the retailer or dealer that sold you the product.

- ▶ Read and follow this instruction manual carefully to help you install, use and maintain your unit.
- ▶ Read the troubleshooting section of this manual as it will help you diagnose and solve common issues.

List of Materials

Quantity	Part	EWC18SRN683	EWC24SRN103
	Door handle (if applicable)	1	1
	Allen/hex key (if applicable)	1	1
	Handle mounting fastener (if applicable)	2	2
	Gasket (if applicable)	2	2
	Stop nut, M5 (if applicable)	2	2
	set screw, M5*10 (if applicable)	2	2
	Anti-tip bracket	2	2
	Anti tip bracket screws and dowels	8	8
	Bracket furniture	8	8
	Counter sunk head screw,ST4x14	20	20
	Truss washer head,ST4*12	16	16
	Position adjustment part	1	1
	Countersunk head screws for fixing wooden doors ST4x35	8	8
	Air vent hinge part(if applicable)	\	1
	90° limit pin	1	1
	Furniture door preparation template	1	1
	Decorative parts	1+2	1+2
	Hinge bracket (only for 24")	\	1
	Hinge bracket (only for 24")	\	1
	User manual	1	1

Product Specifications

Internal Storage EWC18SRN683PR-L / EWC18SRN683PR

DESCRIPTION OF PRODUCT	wine cooler
MODEL	EWC18SRN683PR-L / EWC18SRN683PR
VOLTAGE/FREQUENCY	AC 115/ 50&60Hz
AMPERAGE	1.5A
COLOR	White OR Grey
STORAGE CAPACITY*	68 & 62 Bottles
REFRIGERANT	R600a
TEMPERATURE RANGE	41°F - 68°F
DIMENSIONS (HxWxD)	83 9/16 x 17 3/4 x 23 1/2 (2130x451x597mm)

*Storage capacity is based on standard 12 oz. cans and 750 ml. Bordeaux-style wine bottles.

Internal Storage Bottle EWC18SRN683PR-L / EWC18SRN683PR

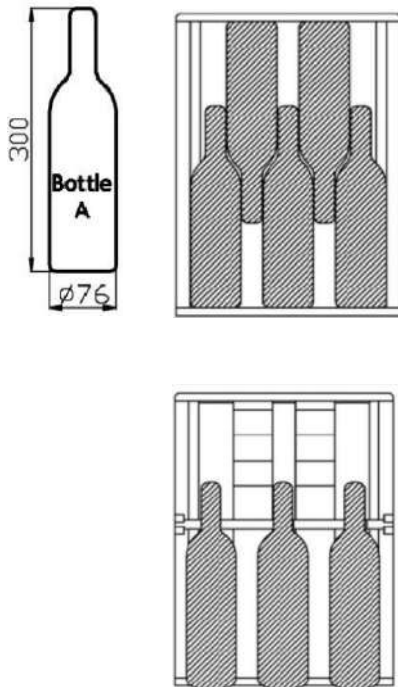
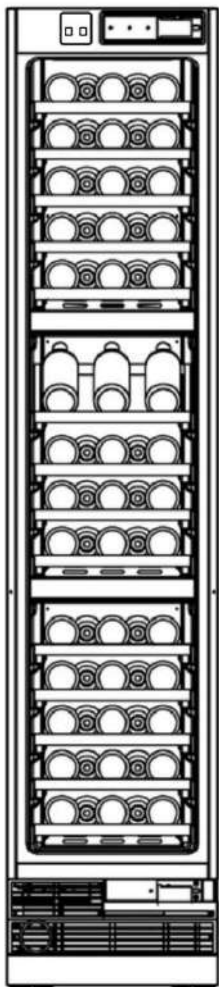

Load capacity		Bottle storage (Bottle A)
Upper zone	1	5
	2	5
	3	5
	4	5
	5	5
Middle zone	1	3
	2	5
	3	5
	4	5
	5	5
Lower zone	1	5
	2	5
	3	5
	4	5
	5	5
Total		68

Product Specifications

Internal Storage EWC18SRN683PR-L / EWC18SRN683PR

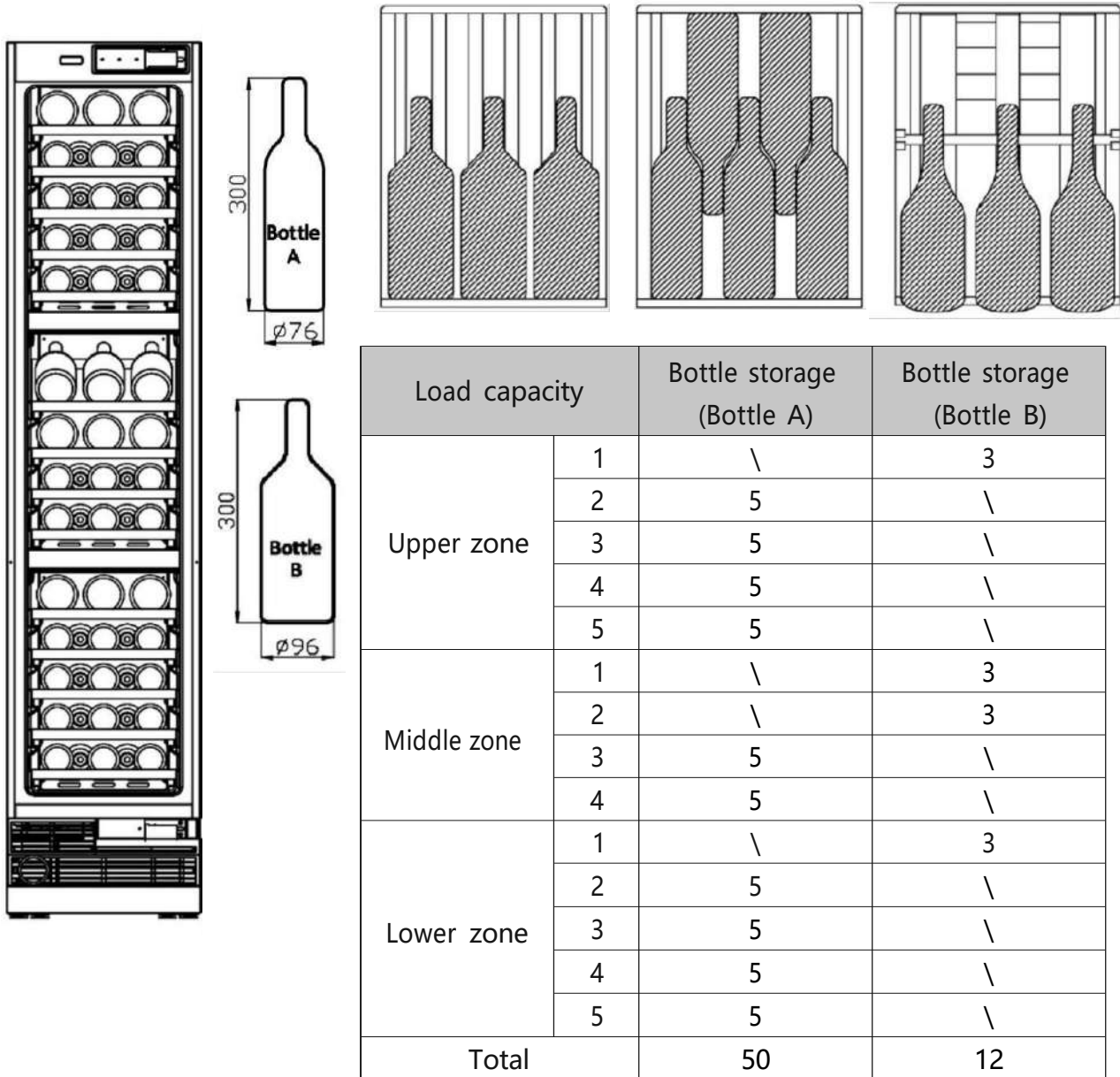

Product Specifications

Parts Identification EWC24SRN103PR

DESCRIPTION OF PRODUCT	wine cooler
MODEL	EWC24SRN103PR
VOLTAGE/FREQUENCY	AC 115/ 50&60Hz
AMPERAGE	1.5A
COLOR	White or Grey
STORAGE CAPACITY*	100 & 94 Bottles
REFRIGERANT	R600a
TEMPERATURE RANGE	41°F - 68°F
DIMENSIONS (HxWxD)	83 9/16 x 23 3/4 x 23 1/2 (2123 x 603 x 597mm)

*Storage capacity is based on standard 12 oz. cans and 750 ml. Bordeaux-style wine bottles.

Internal Storage EWC24SRN103PR

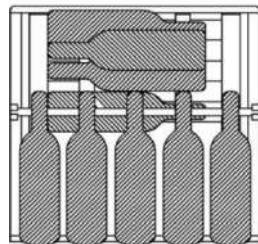
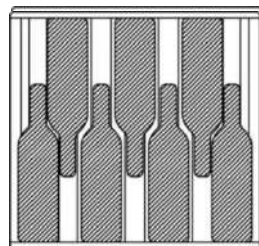
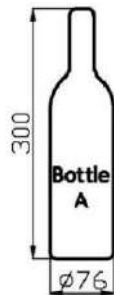
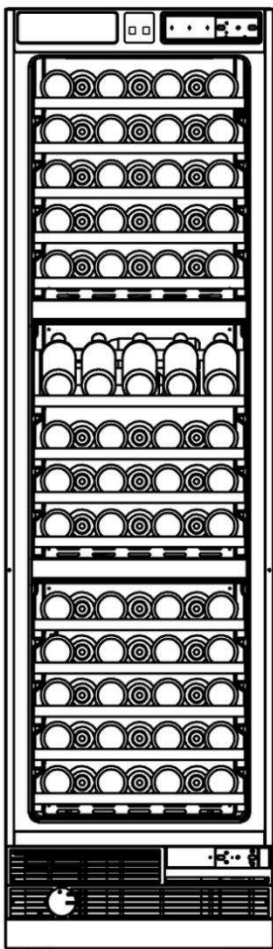

Load capacity		Bottle storage (Bottle A)
Upper zone	1	7
	2	7
	3	7
	4	7
	5	7
Middle zone	1	9
	2	7
	3	7
	4	7
Lower zone	1	7
	2	7
	3	7
	4	7
	5	7
Total		100

Product Specifications

Internal Storage EWC24SRN103PR

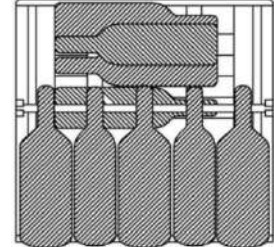
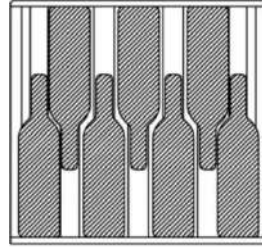
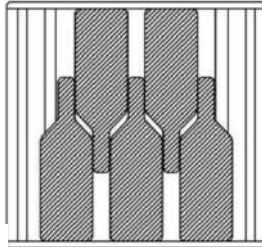
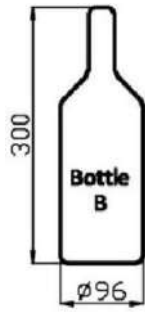
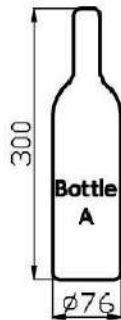
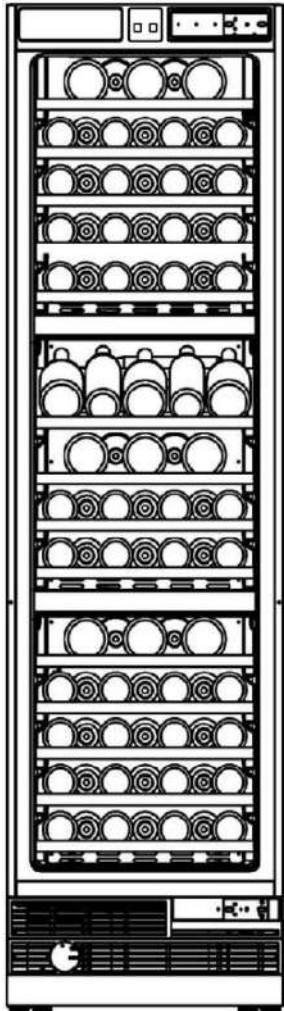

Load capacity		Bottle storage (Bottle A)	Bottle storage (Bottle B)
Upper zone	1	\	5
	2	7	\
	3	7	\
	4	7	\
	5	7	\
Middle zone	1	6	3
	2	\	5
	3	7	\
	4	7	\
Lower zone	1	\	5
	2	7	\
	3	7	\
	4	7	\
	5	7	\
Total		76	18

Product Specifications

Parts Identification EWC24SRN103PR

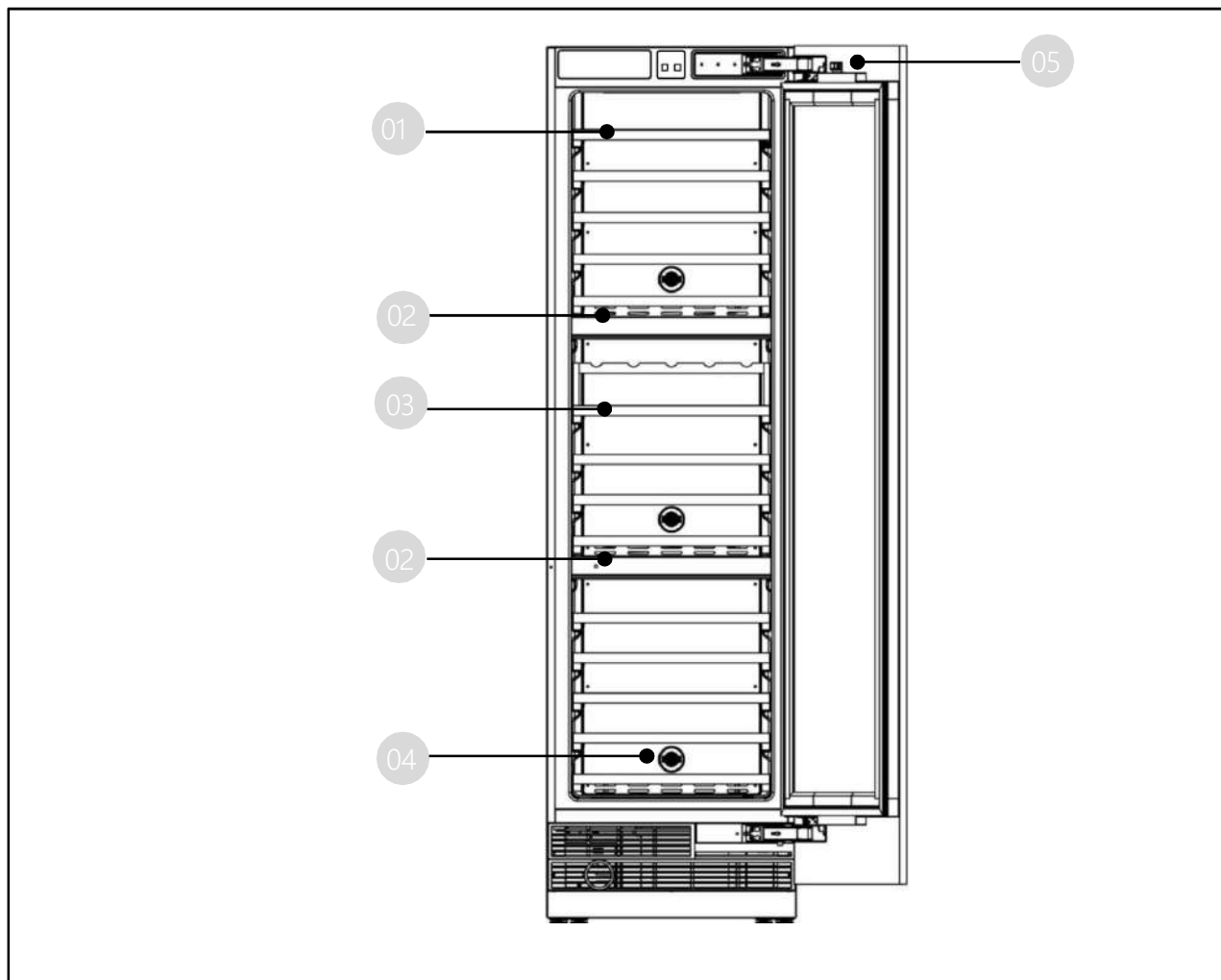

01 Wine Shelf A

03 Wine Shelf B

05 Electromagnetic Switch

02 Control Panel & Compartment Wall

04 Carbon Filter

Installation Instructions

Installation dimensions

Wood panel cutout dimension and installation clearance

	EWC18SRN683PR	EWC24SRN103PR
A	17 3/4" (451mm)	23 3/4" (603mm)
B	12 1/4" (311mm)	18 1/4" (463mm)
C	18" (457mm)	24" (609mm)
D	17 3/4" (451mm)	23 3/4" (603mm)

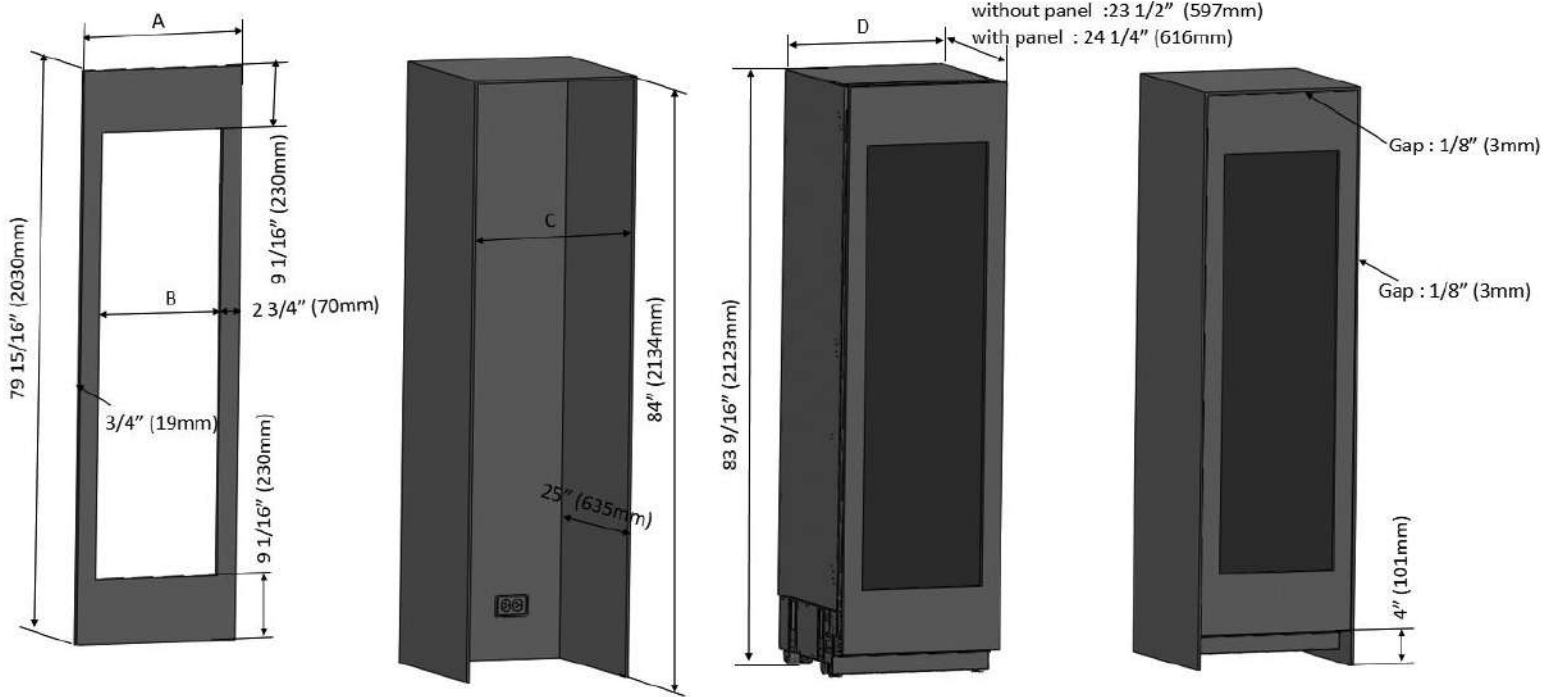

Installation dimensions

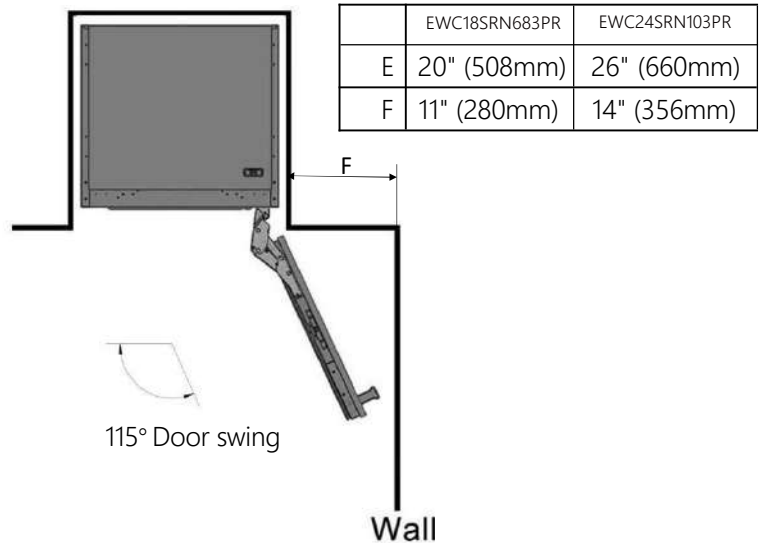
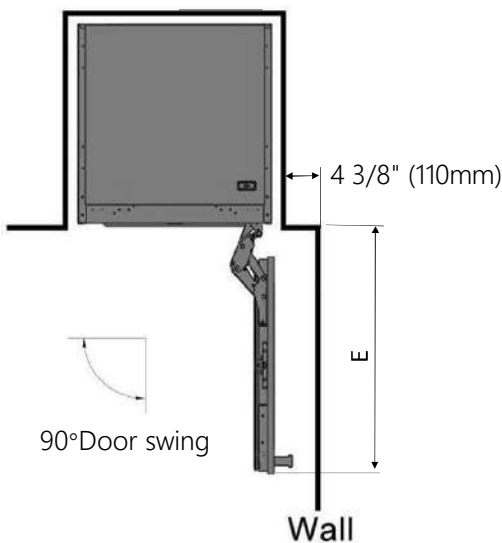

	EWC18SRN683PR	EWC24SRN103PR
E	20" (508mm)	26" (660mm)
F	11" (280mm)	14" (356mm)

Installation Instructions

	A	B
standard	4" (101)	84" (2134)
minimum	3 3/4" (95)	83 3/4" (2127)
maximum	5 5/16" (135)	85 5/16" (2167)

	EWC18SRN683PR	EWC24SRN103PR
C	18" (457mm)	24" (609mm)
D	17 3/4" (451mm)	23 3/4" (603mm)

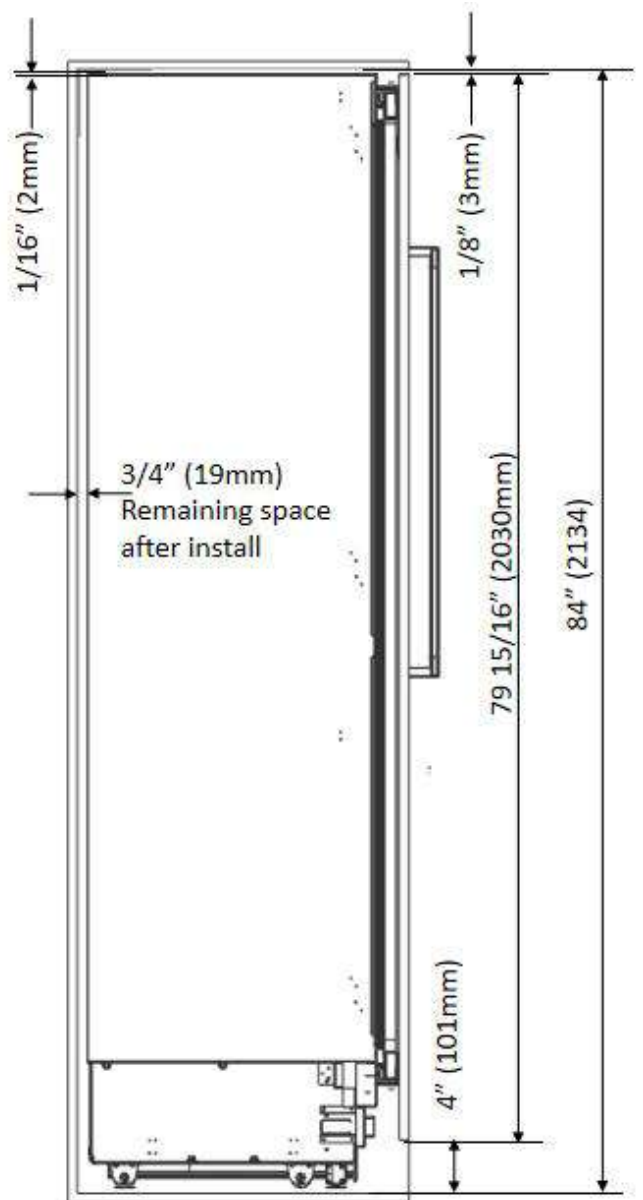
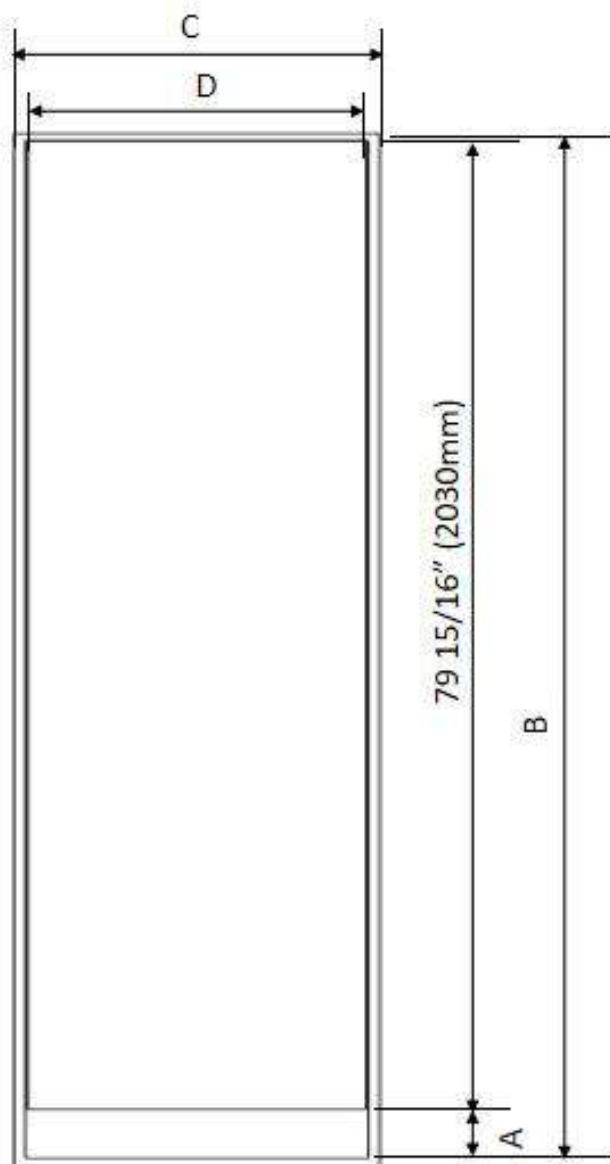

Installation Instructions

Anti tip brackets location

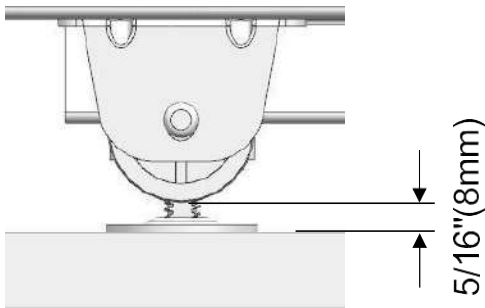

Minimum height adjustment for leveling

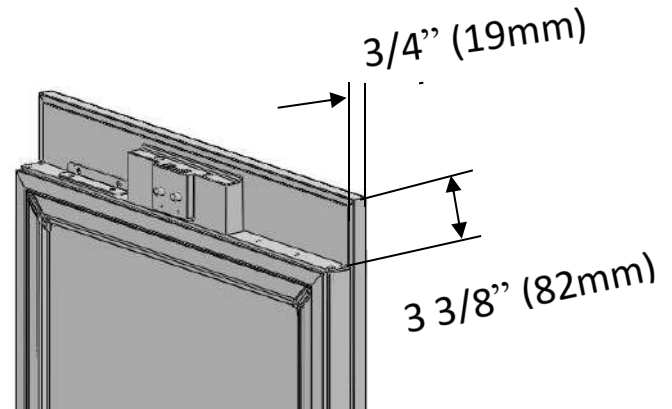

Assembly dimension between Wood panel and fridge door

Installation Instructions

Electrical location

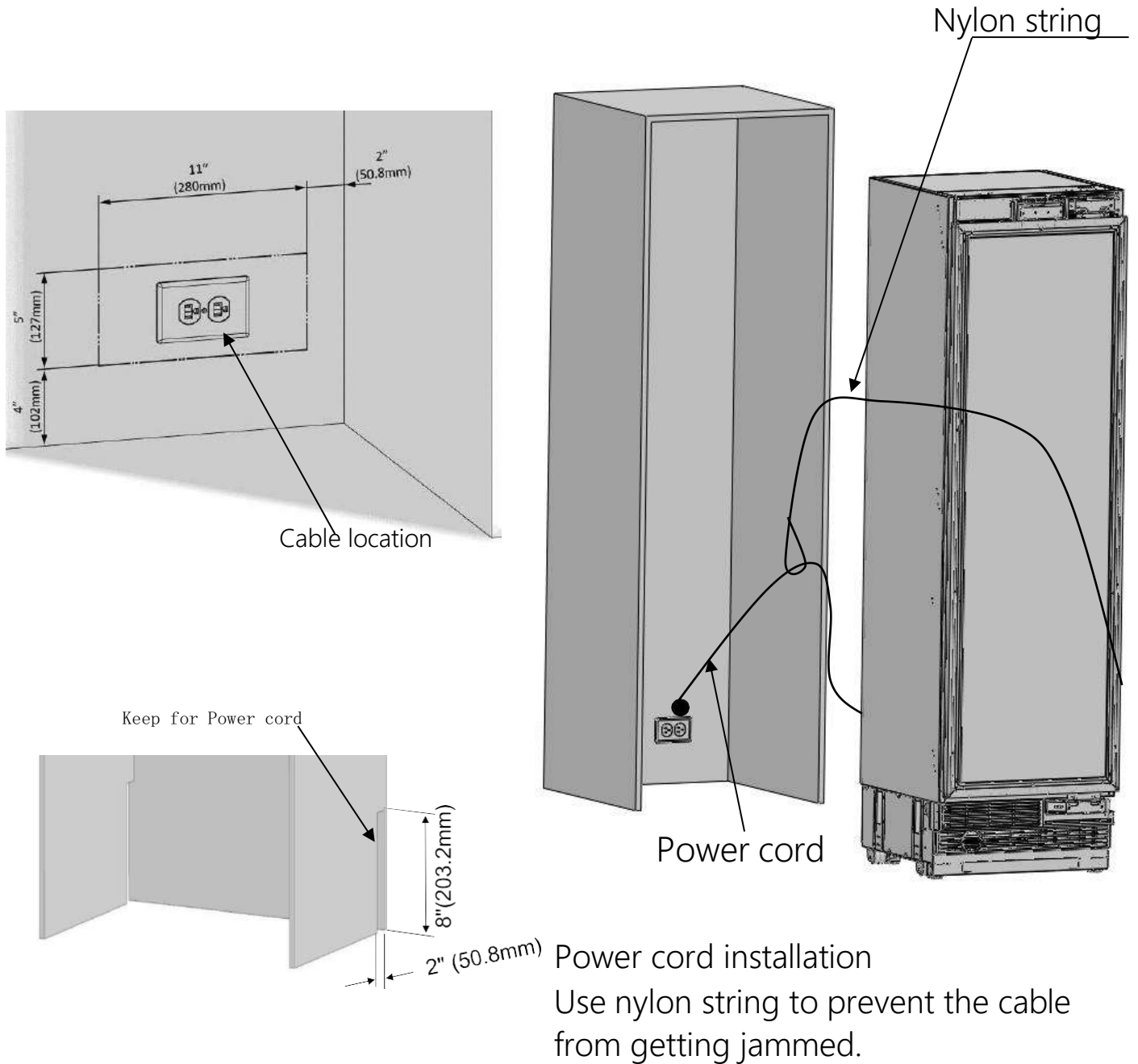

Installation Instructions

Carbon Filter

A built-in carbon filter protects your beverages by acting as a natural barrier against harmful odors. The carbon filter should be replaced every 3-6 months depending on the unit's exposure level to odor. If the unit is placed in a kitchen, regular replacement every three months is ideal.

Remove the carbon filter by turning counterclockwise to unlock from rear panel.

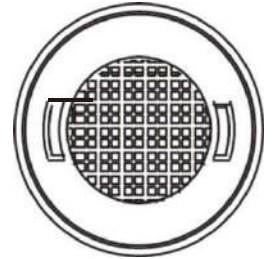
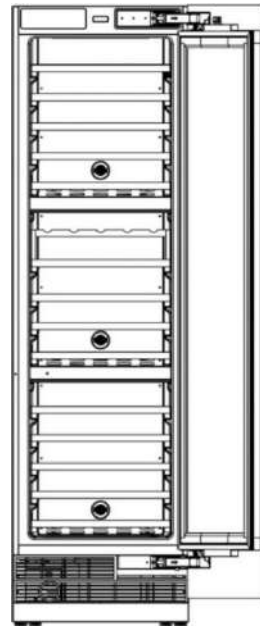

Install the handle (if applicable)

If a pro handle or different colored contemporary handles are desired, refer below for the handle dimensions and part number.

1. Align the handle fixing holes with the holes on the wooden door, then install the handle with a screwdriver.

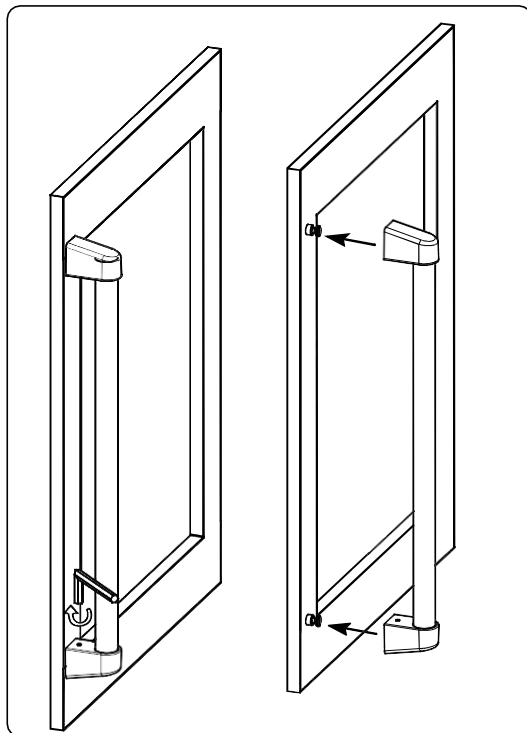

Installation Instructions

Changing the door opening direction

EWC24SRN103PR

Should you desire to reverse the opening direction of the door, please follow the instructions below. Safely reversing the door swing of your appliance should require at least two people.

- Remove the hinge connection screws of the Hinge Brackets.

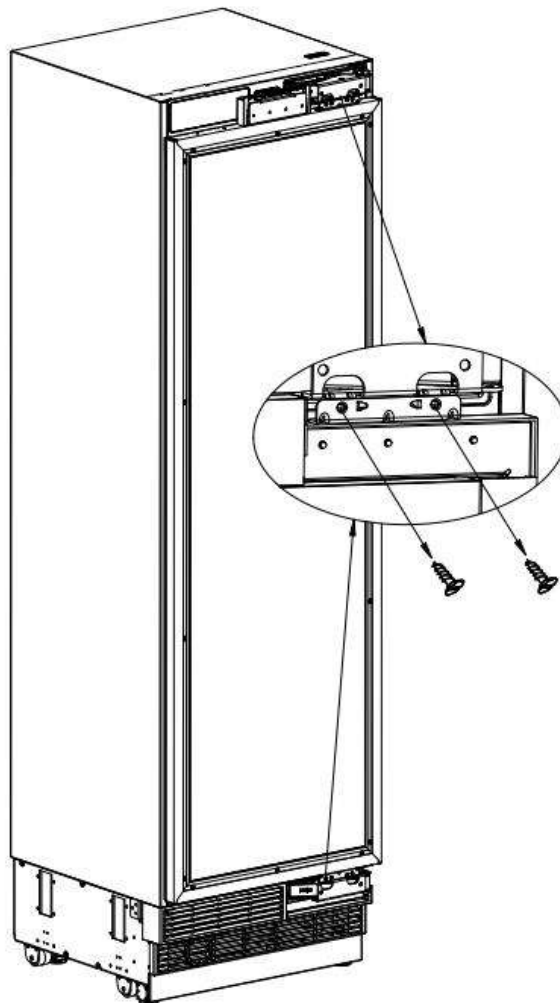

ATTENTION:

The clad door will be released when these screws are removed.

You must take measures to prevent the door from falling.

You can tape the Furniture Door to the Inner Door or ask for help from another person.

Installation Instructions

- Take out door and lay it down on a table.
- Remove the hinge brackets on the fridge door.
- Take out the new hinge brackets from **Accessories bag** and screw it on the reverse side.

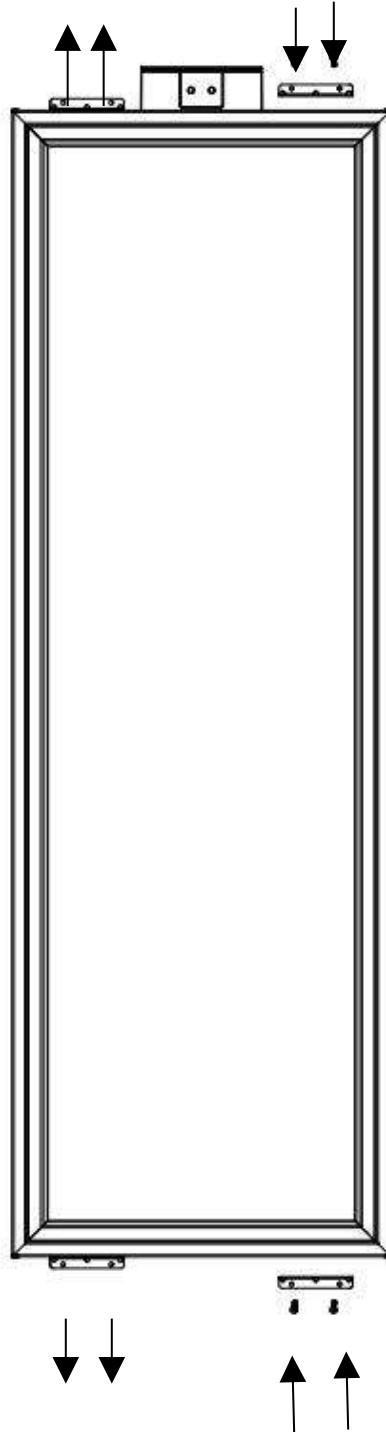

Installation Instructions

- Remove the Hinge Caps located at the other side where you will fix the hinges.
- Remove the lower right hinge by loosening its 2 screws and fix it to its slot at the upper left side.

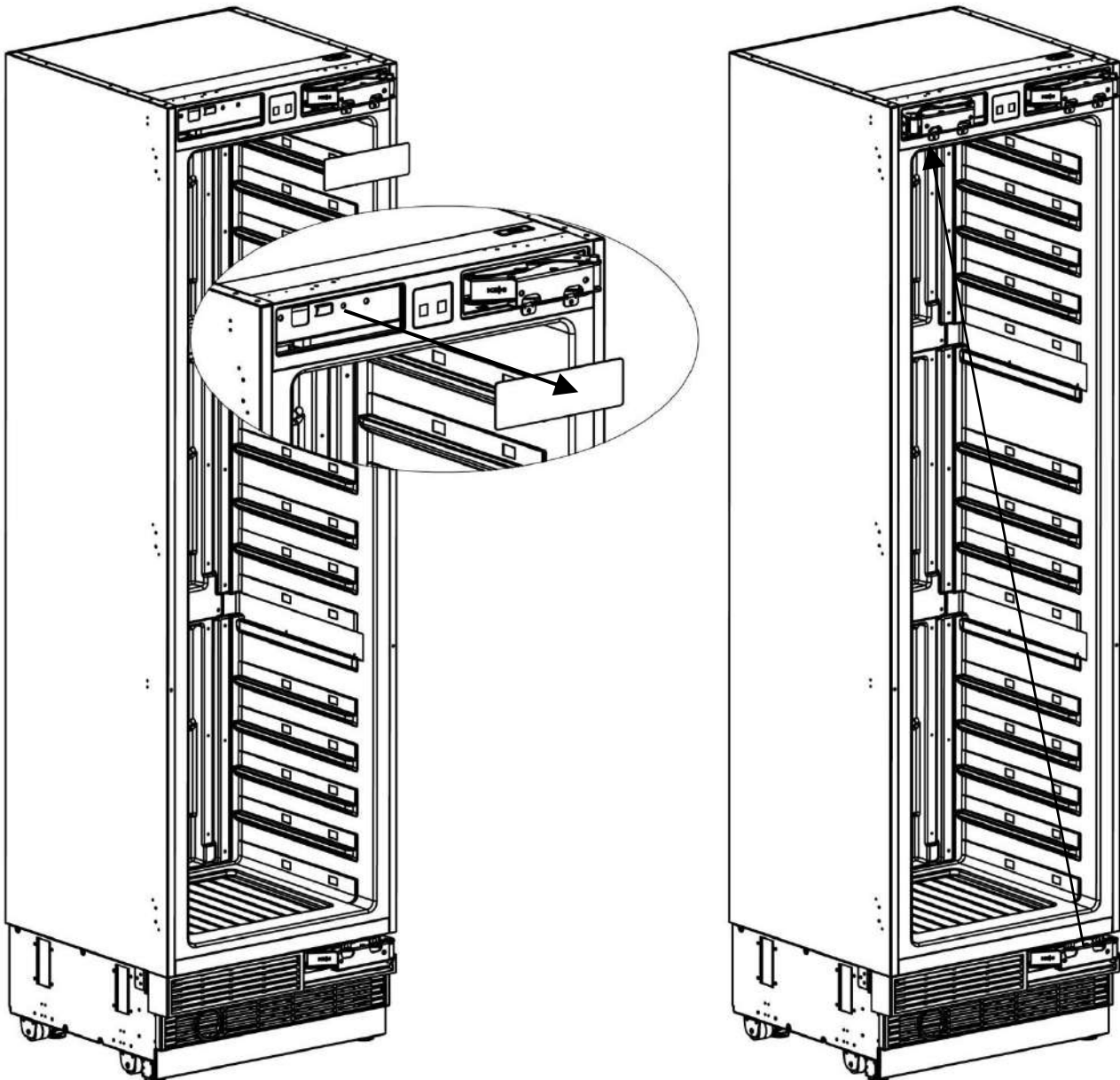

Installation Instructions

- Remove the air vent part and change direction as shown figure.

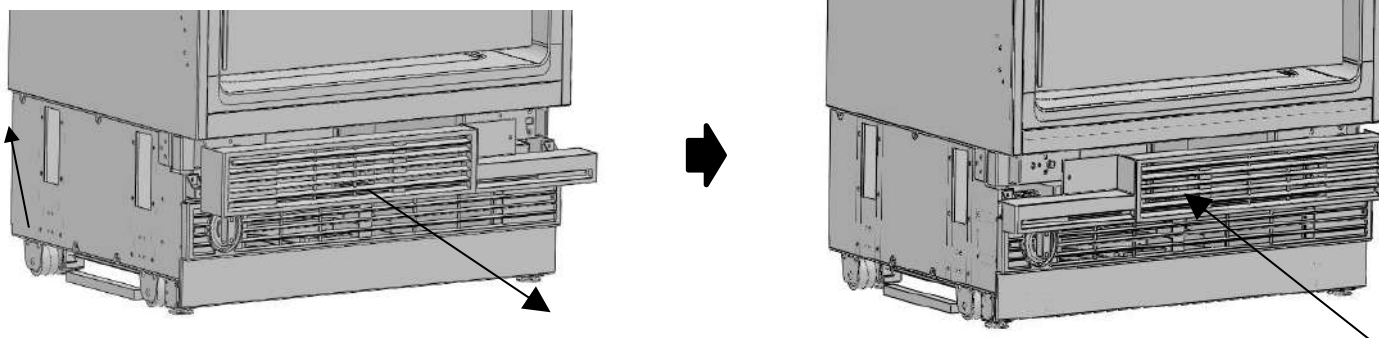

- How to change air vent upper part direction

Air vent upper part for the right hinge

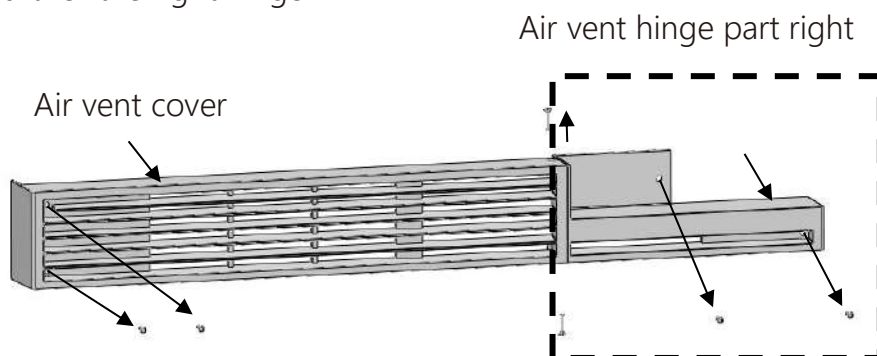

Air vent upper part for the left hinge

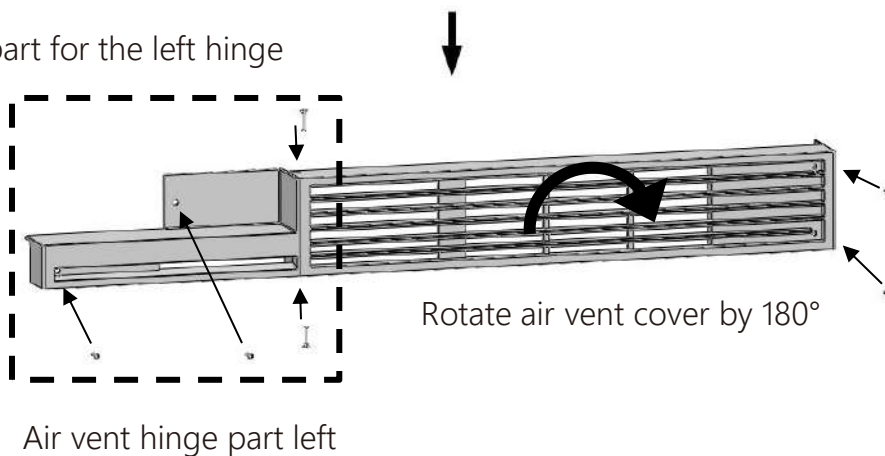

Installation Instructions

- Remove the upper right hinge by loosening its 2 screws and fix it to its slot at the lower left side.
- Attach the Hinge Slot Caps removed from the left side to the Hinge Caps to the right side.

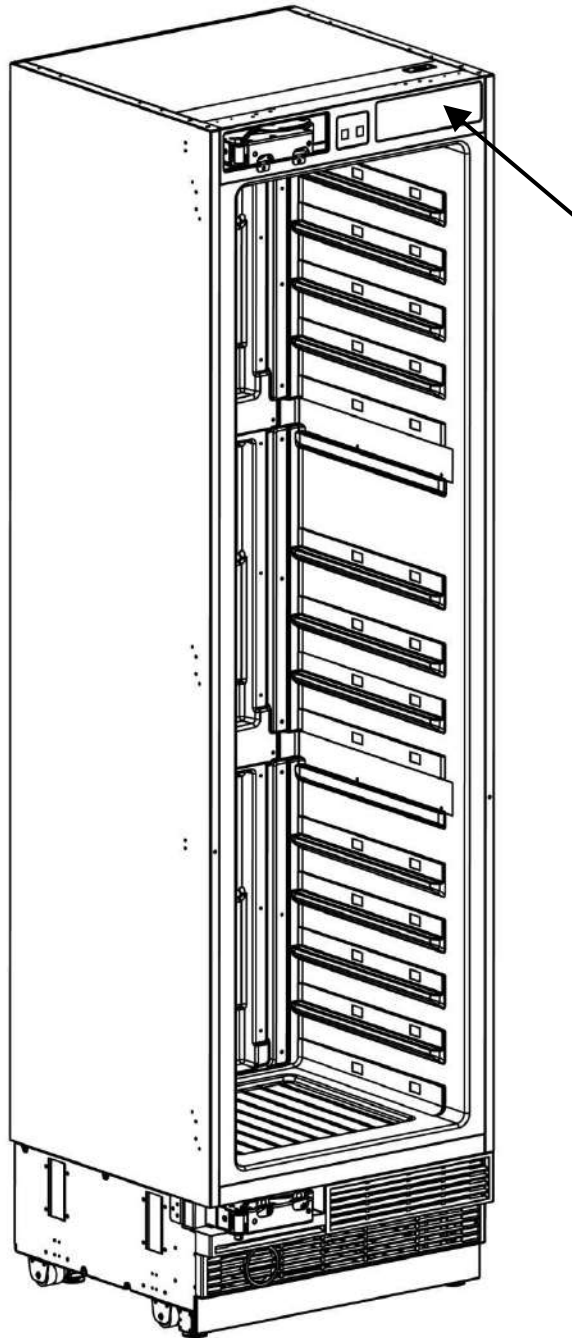
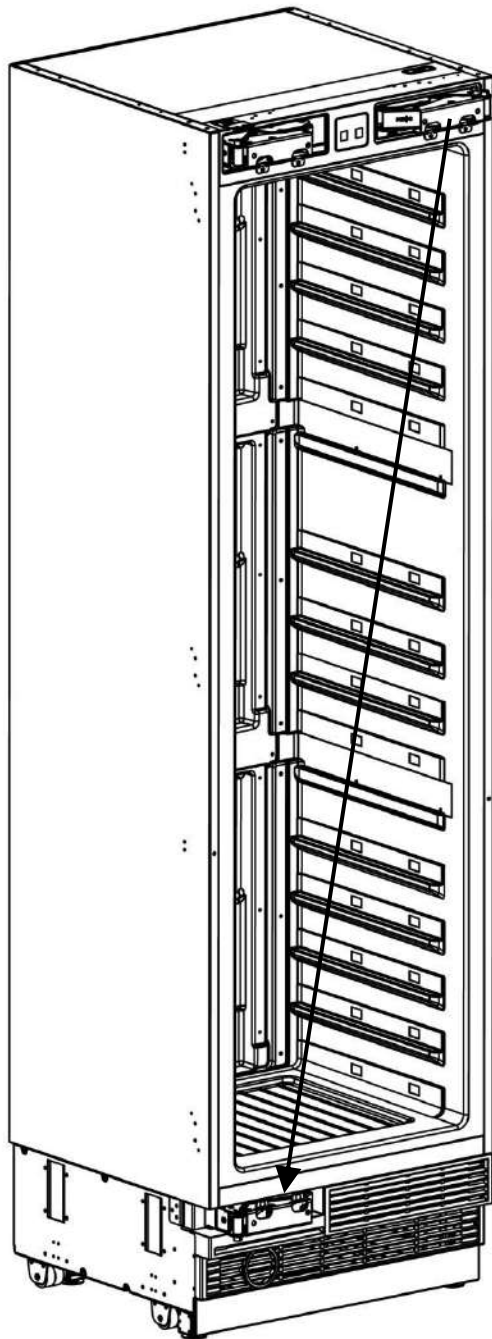

Installation Instructions

- Place the door to the refrigerator and fix it with 4 screws.

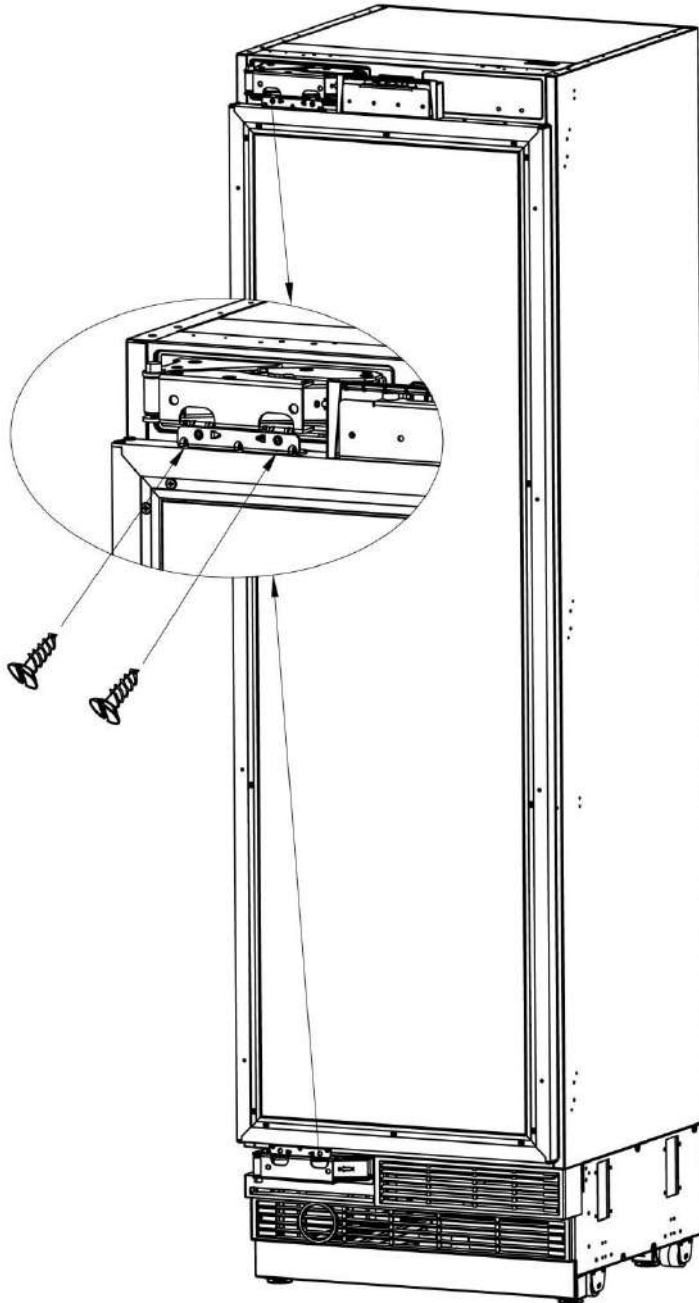

Installation Instructions

Removing the packing

- Use a box cutter to remove the tapes.
- Cut the Packaging Board with a Box Cutter through the section illustrated in dotted lines and remove it.



At least two persons must carry the refrigerator.

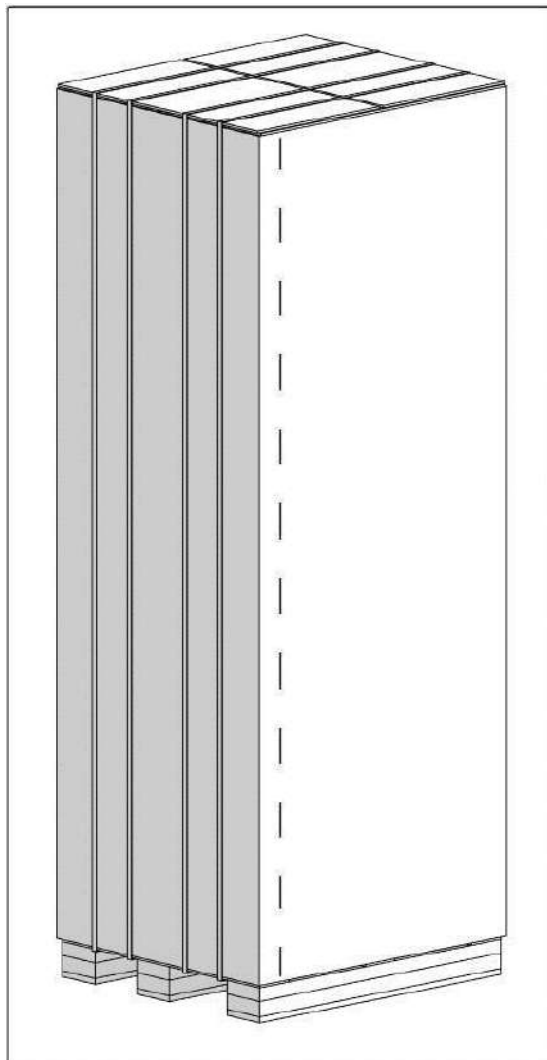

Installation Instructions

- Remove the Packaging Polystyrene material.



Do not remove the tape of the upper door on the product until the refrigerator is placed into the cabin. Risk of tipping over.

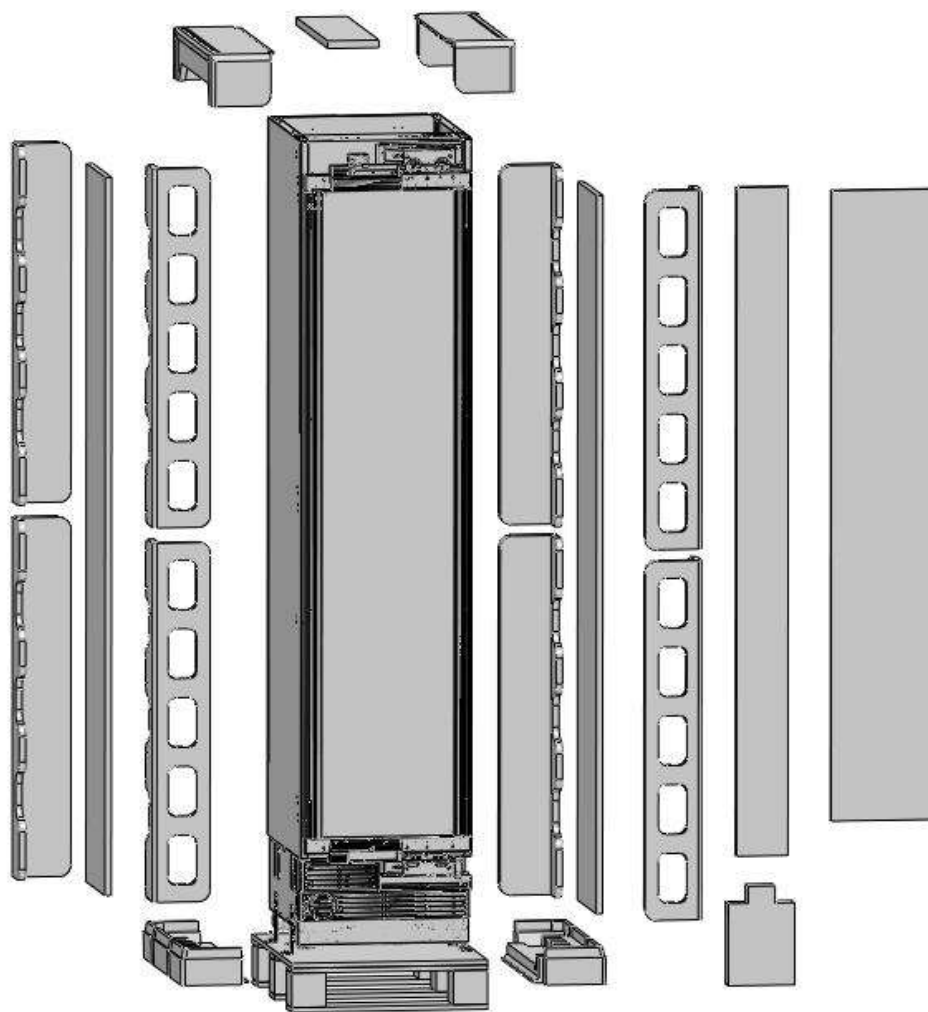

Installation Instructions

Taking the refrigerator from the wooden pallet

- Remove the brackets that connect the refrigerator to the Wooden Pallet.
- Recline the wine cooler slowly and pull back with the help of the cart, and then land it.

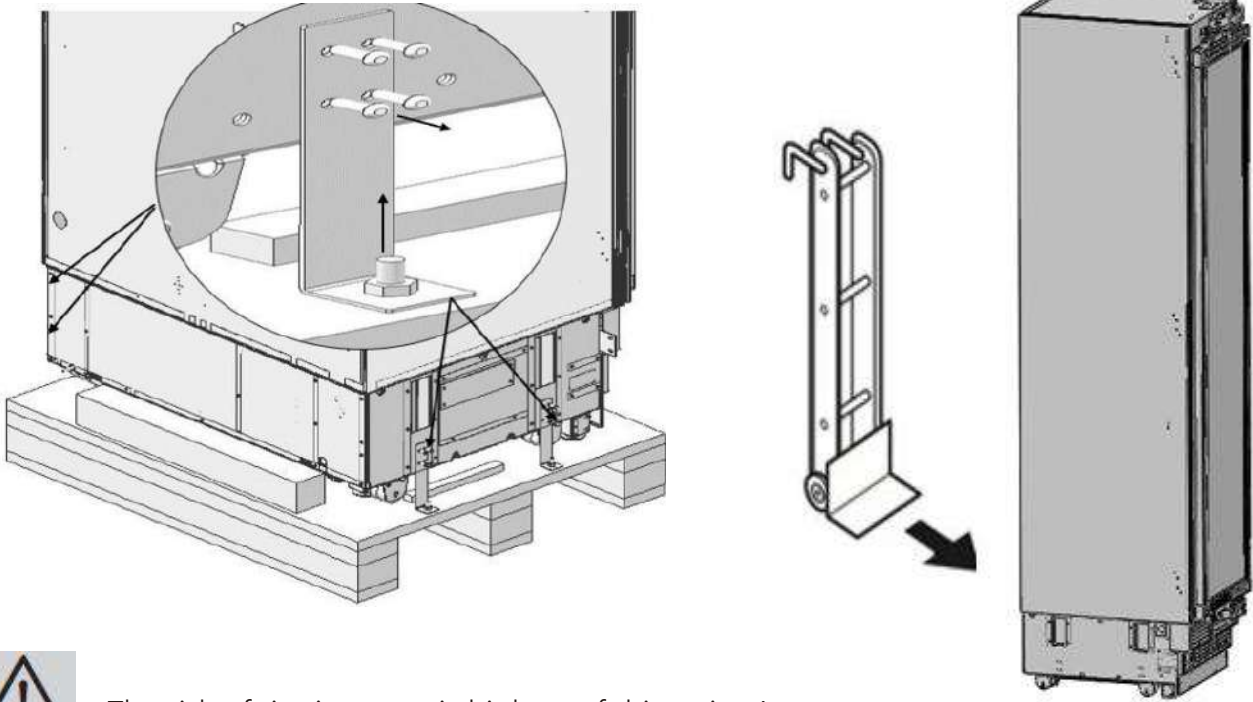

The risk of tipping over is high as of this point. You should not open the doors until the product is placed into the cabin.

Removing the vent hole assembly

- Remove 5 screws to take out the Vent Hole Assembly.

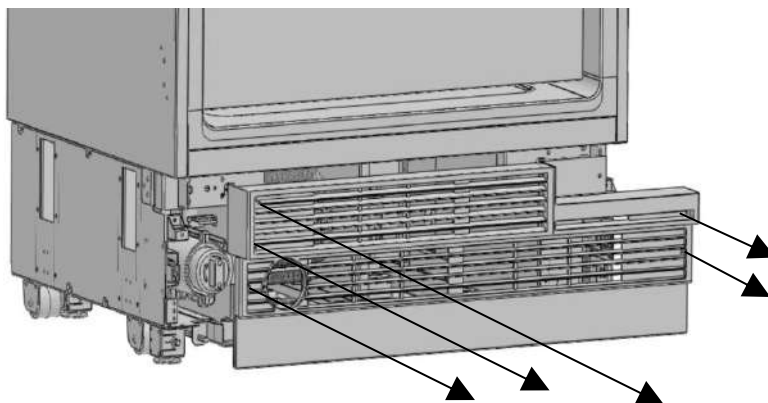

Installation Instructions

Mounting the anti-tip brackets

- Mark the wall for anti-tip brackets

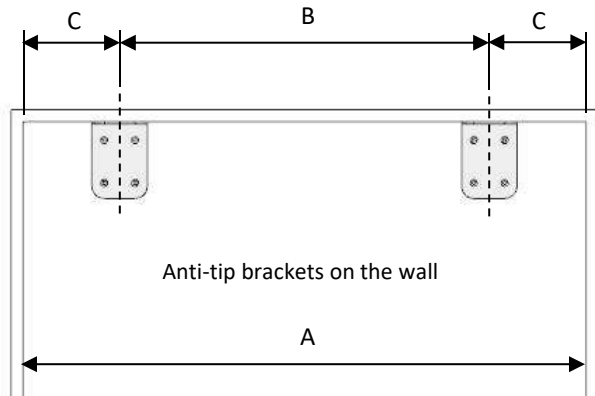

Category	EWC18SRN683PR	EWC24SRN103PR
A	18" (457mm)	24" (609mm)
B	11 5/8 (295mm)	17 5/8 (447mm)
C	3 3/16" (81mm)	3 3/16" (81mm)

- Use a drill to create holes for dowels at the marked points. (5/16" -Ø8)

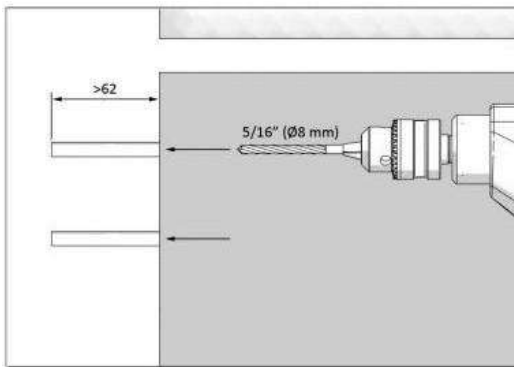

- Use the hammer to fit the dowels

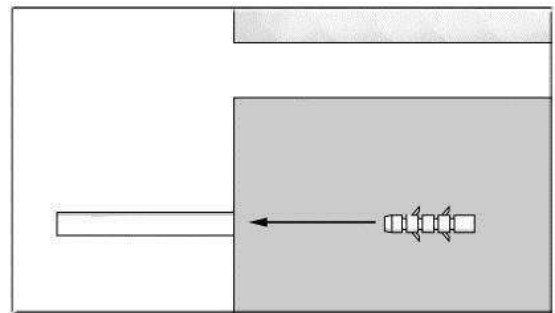

- Fit the brackets into their places, using 4 screws for each.
- You must use all of the 2 brackets to ensure safety of the product.



Please remember to use the necessary protective equipment when drilling holes on the wall and performing installation.

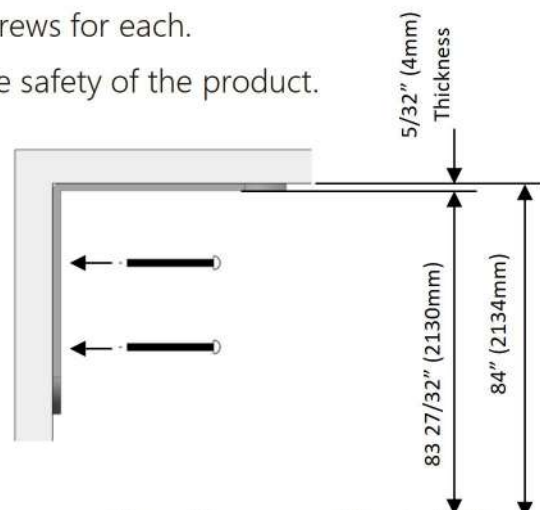

Use, Care, and Installation Guide

Installation Instructions

Screwing the side and upper brackets

- Fix the bracket furniture to the unit, where 2 on the top, and 3 on every side.
- Use the truss washer head screws(ST4*12) to tighten.

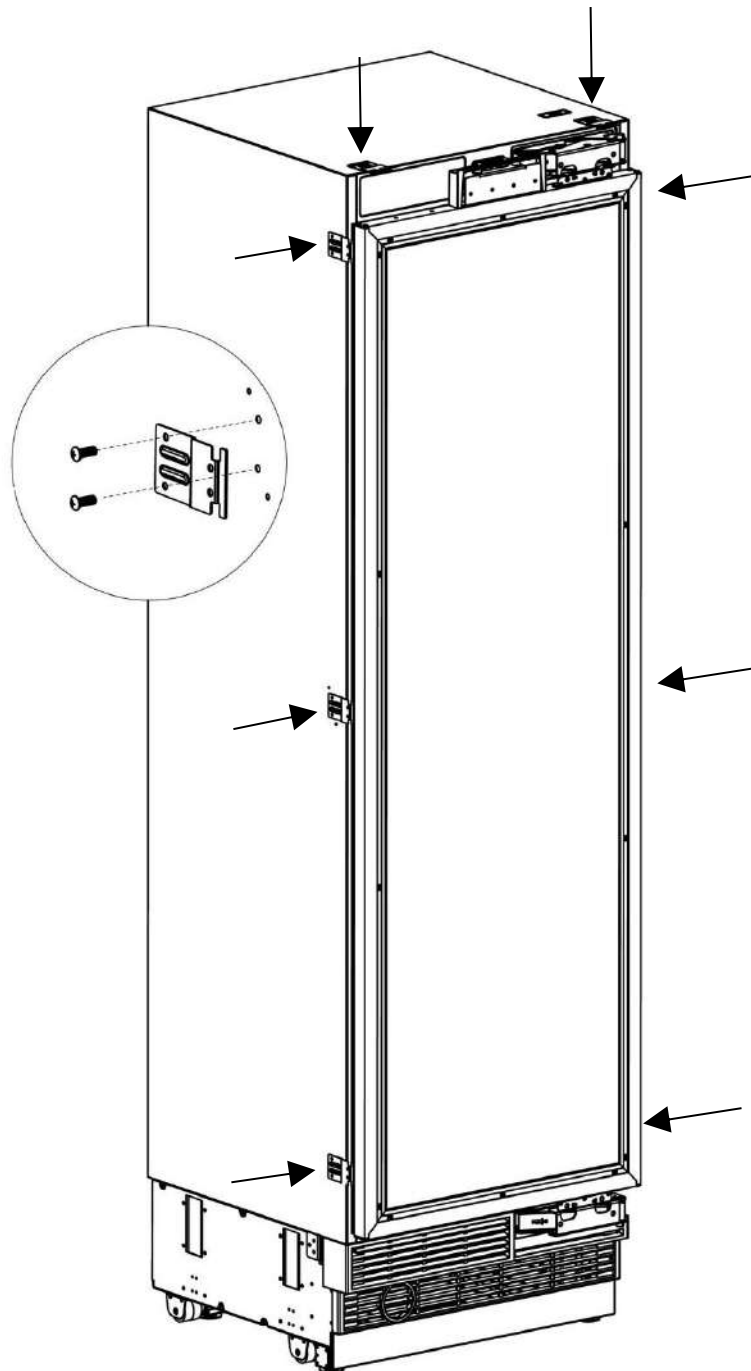

Installation Instructions

- Push the product carefully towards the cabin to place it.

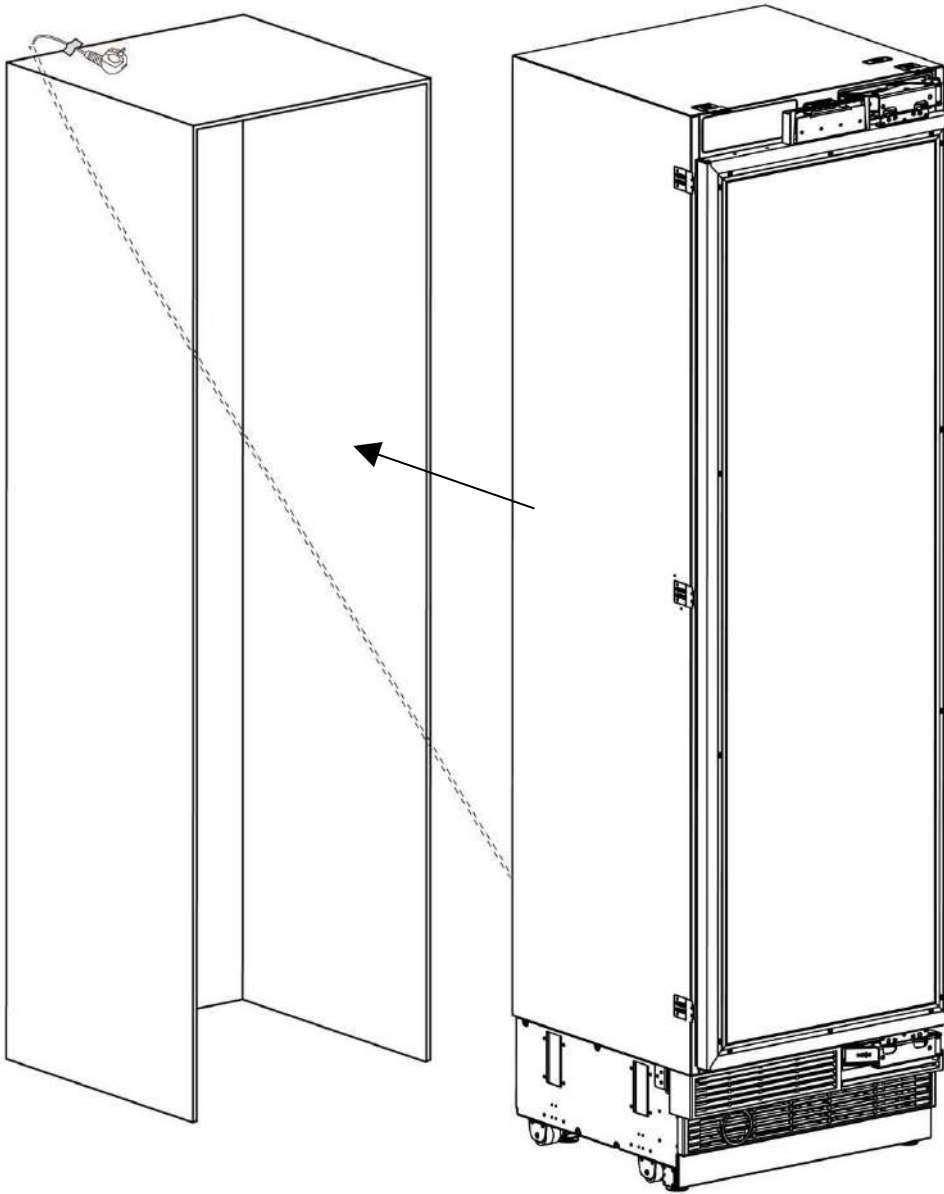

The plug of the product must be accessible after installation.

Adjusting the height of the wine cooler in the cabin

- Adjust the wine cooler height using the adjustable feet.

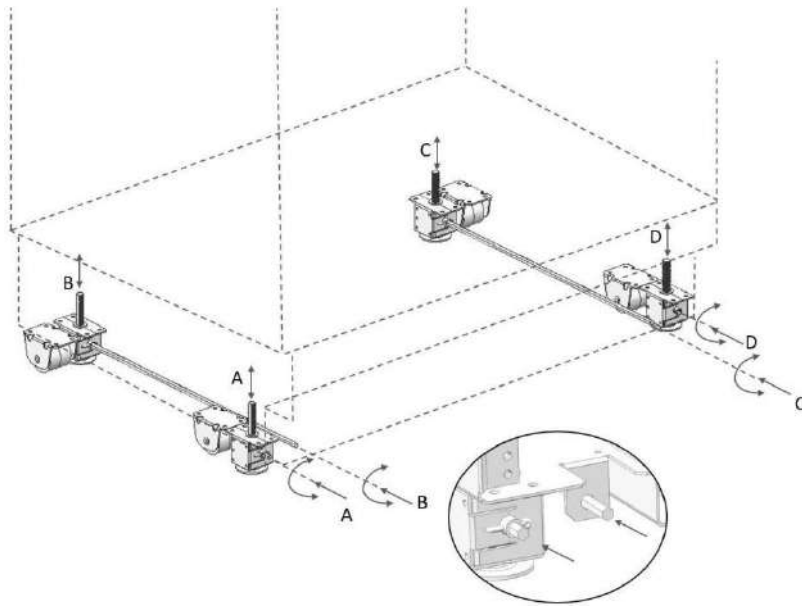

First of all, raise the front feet to reduce the risk of the cabin falling forward.

A/D –Turn the key clockwise to lift the front

B/C –Turn the key clockwise to lift the rear

- After adjusting the adjustable feet, check the flatness in both width and depth directions.

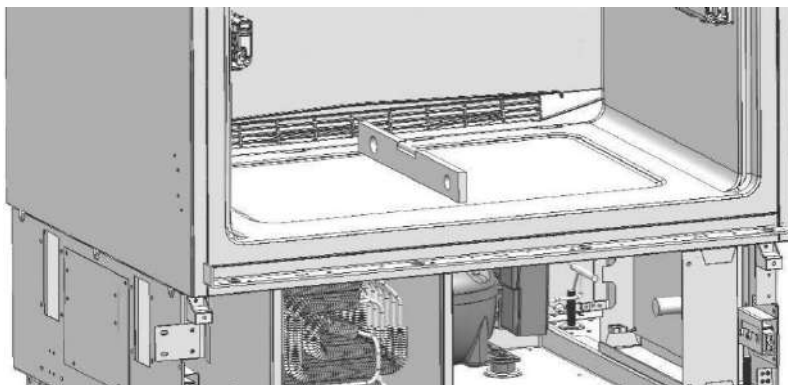

Installation Instructions

Adjusting the refrigerator according to the cabin flange

- Position of the level adjustment must be adjusted according to the thickness of the door.

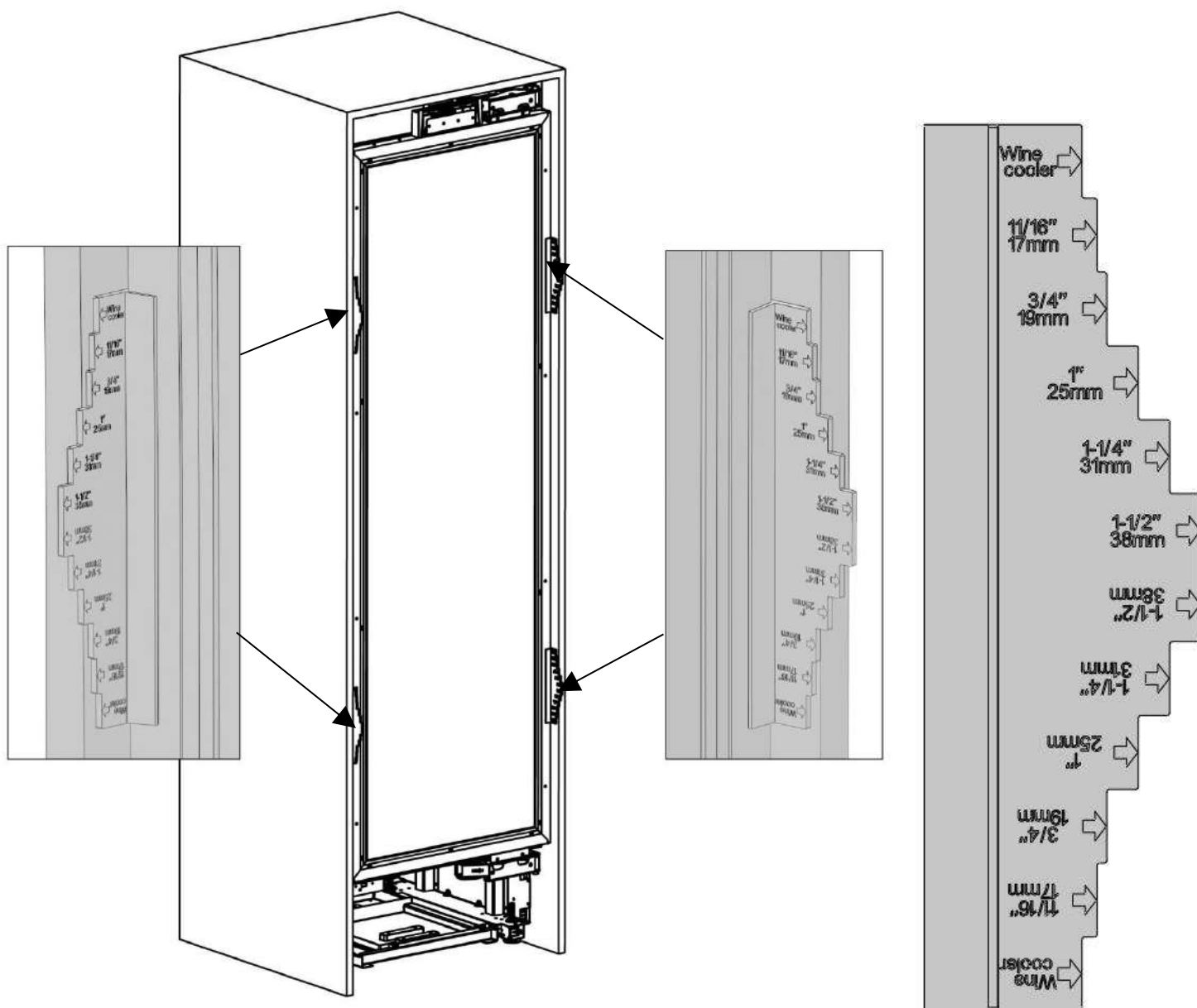

Screwing the side and upper brackets

- Attach the bracket furniture to the furniture with 16 screws(ST4x14).

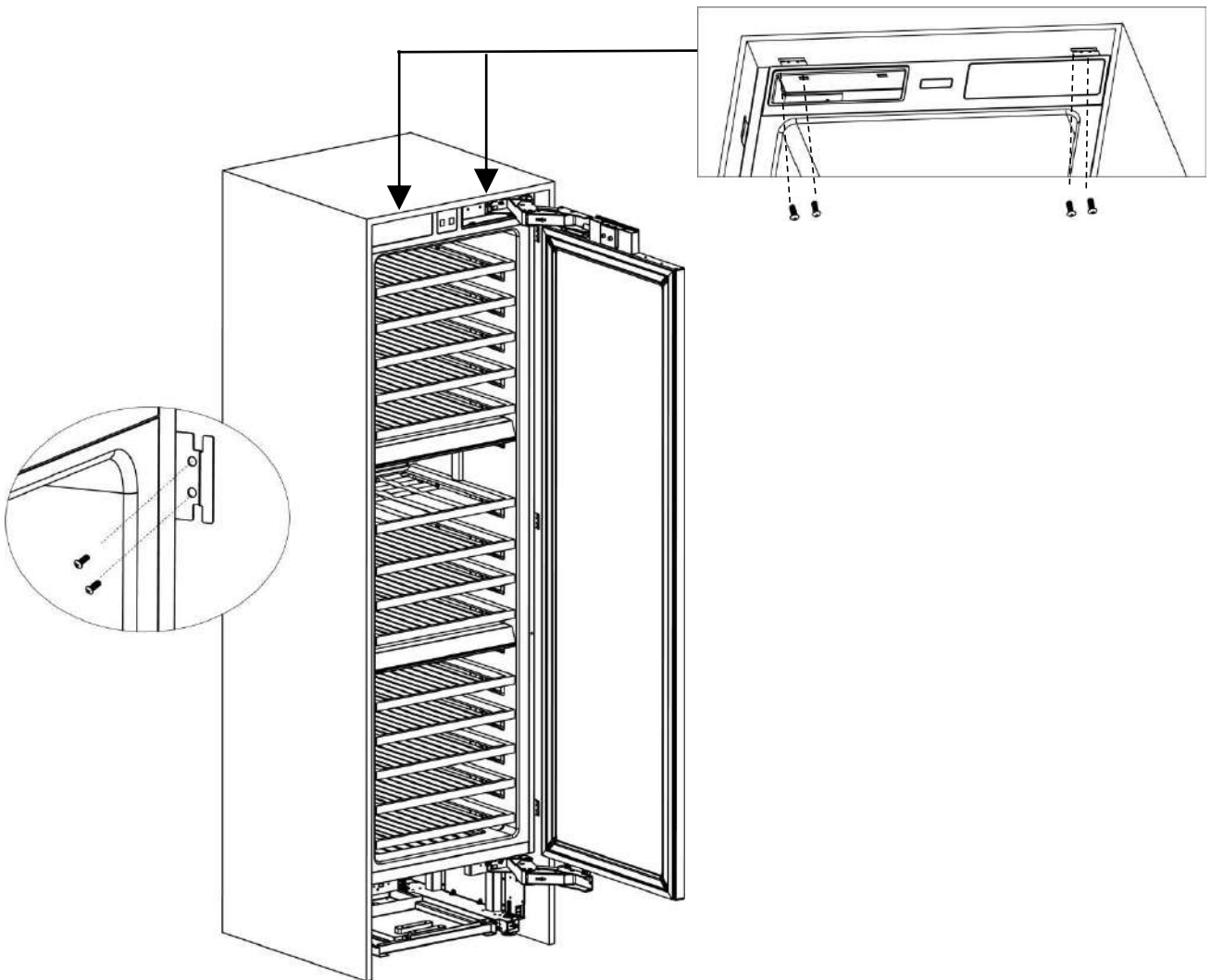

Installation Instructions

Attaching the vent hole assembly

- Use 5 screws to attach the vent hole assembly.

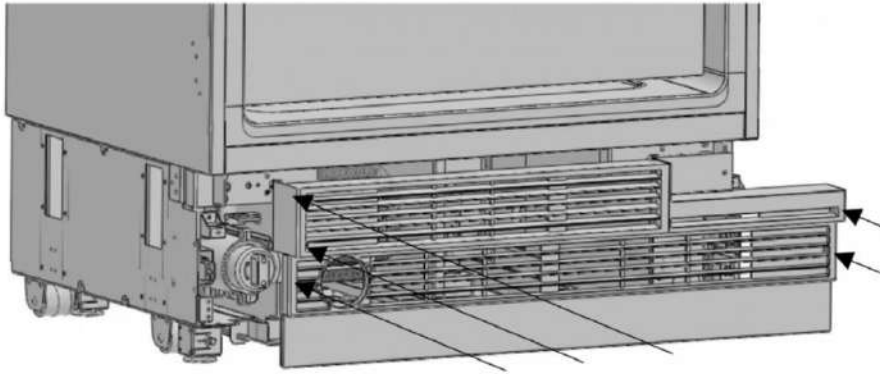

Installation Instructions

Attaching the decorative parts

- Attach the side closing parts onto the right/left/upper connection brackets.

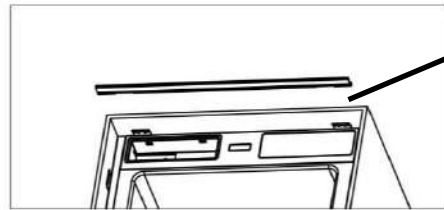

EWC18SRN683PR: 457mm;
EWC24SRN103PR: 609mm

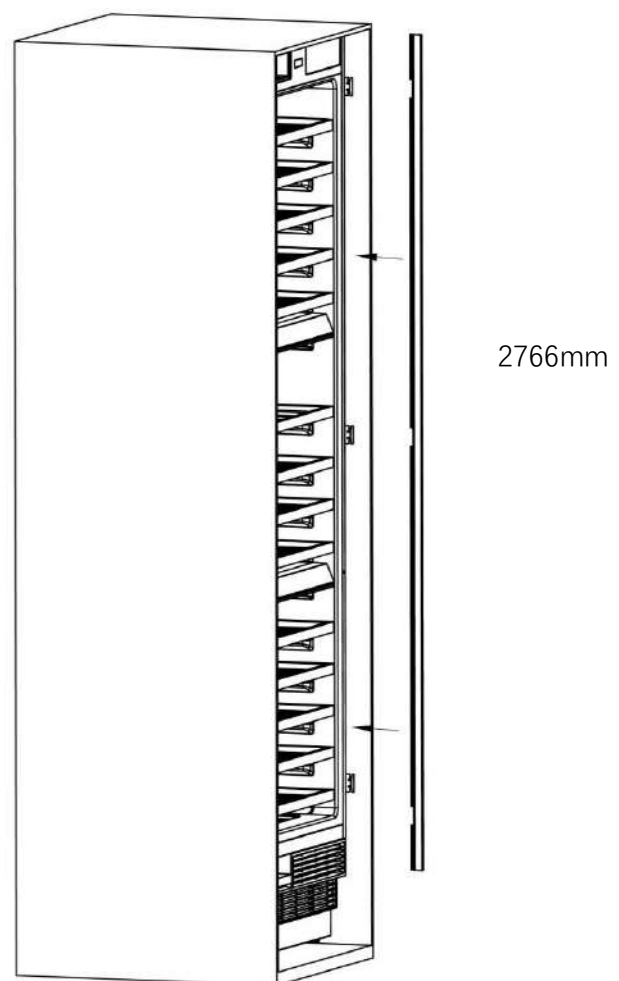
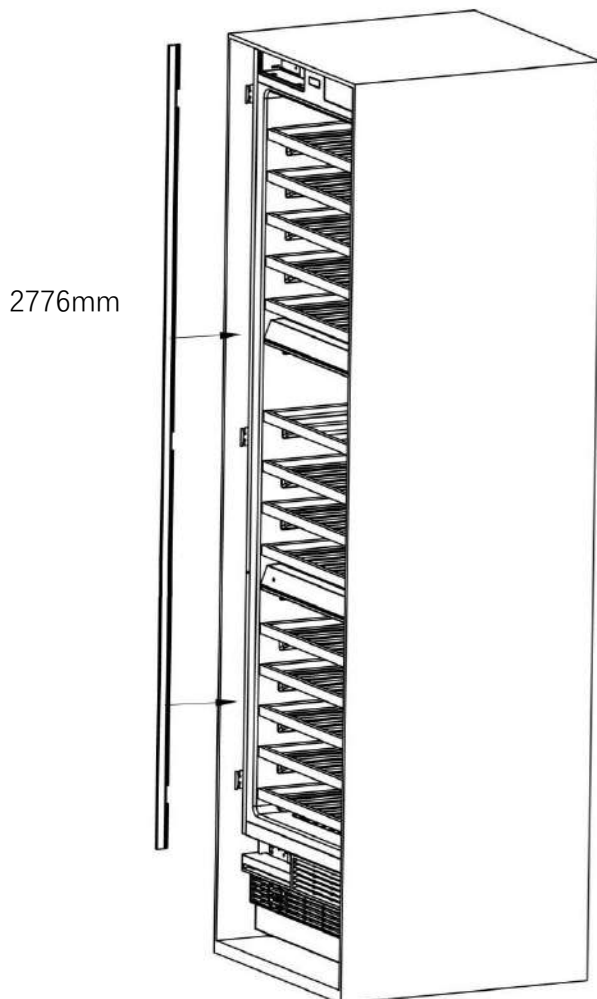

Installation Instructions

Removing the panel-adjustment mechanisms on the refrigerator

- Remove screws to take out the top hanger bracket cover.



There is a magnet on the top hanger bracket cover. This is a functional part for the operation of the product. It should not be confused with the low hanger bracket cover.

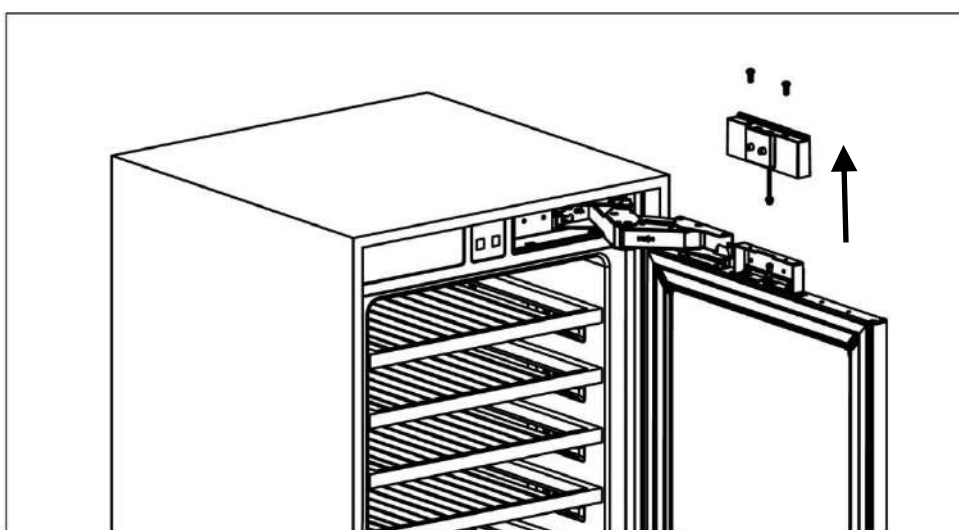

- Remove the upper and lower adjusting mechanism assemblies from the door.

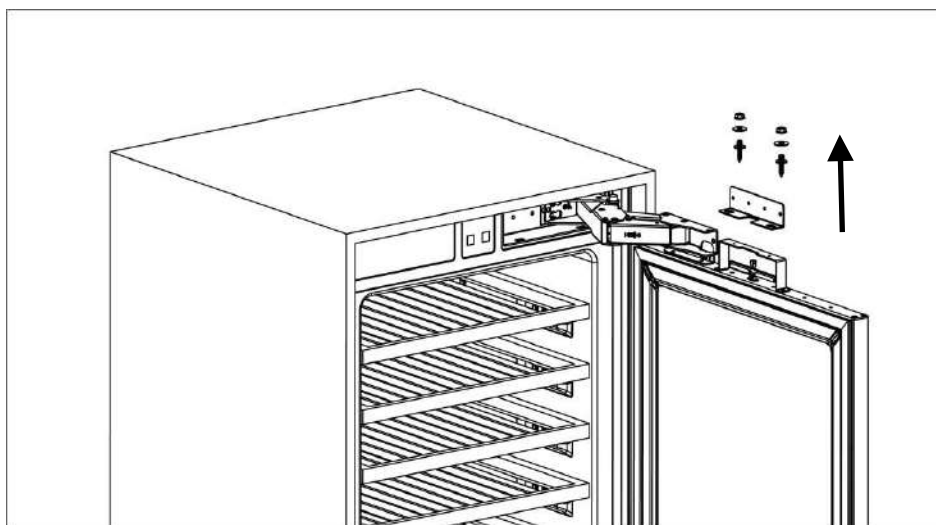

Installation Instructions

Preparing furniture door

- When marking, you can use the "Furniture door preparation template" provided with the product.

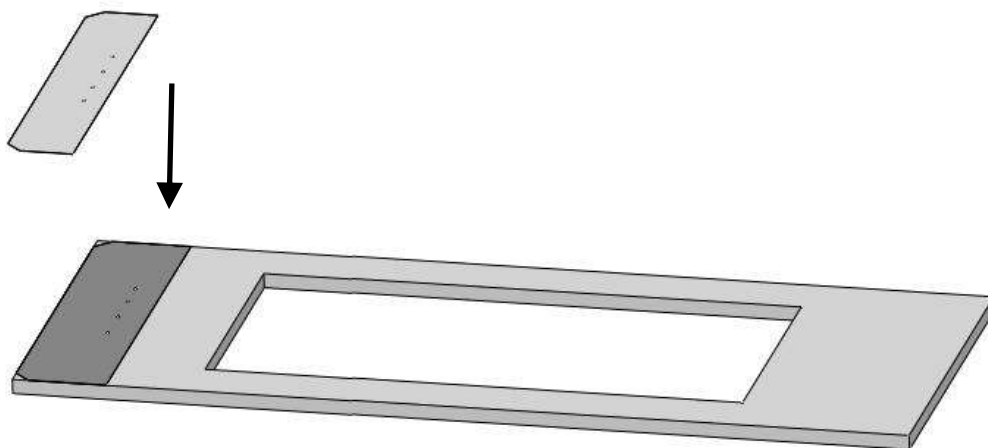

- Install cradles using the chipboard screws(ST4x14).

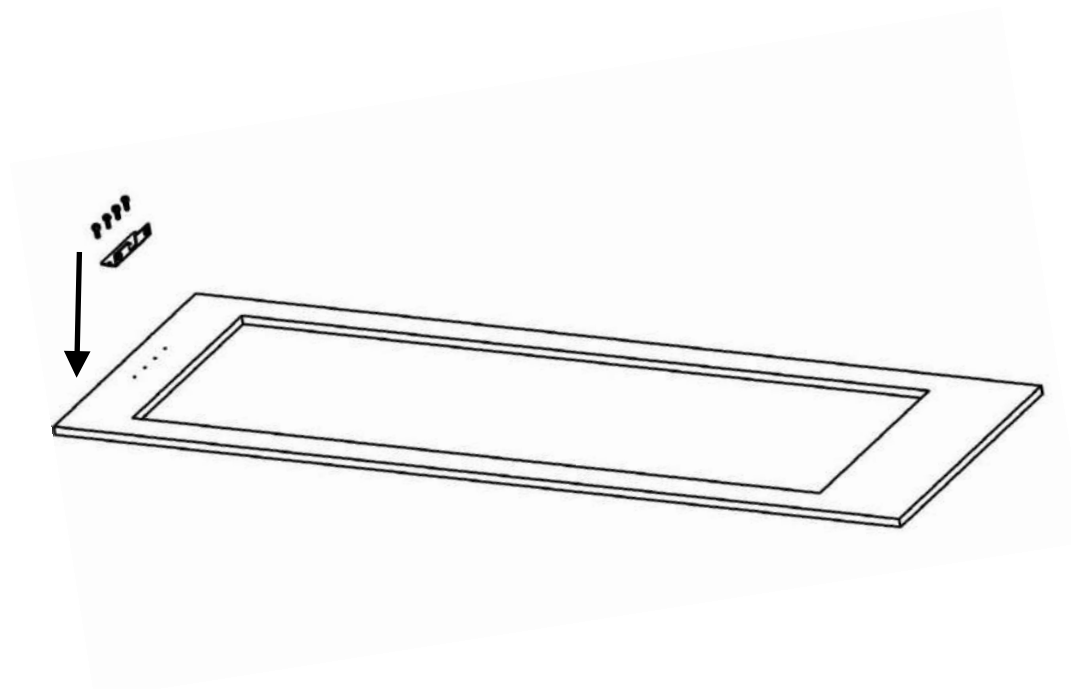

Installation Instructions

Installing the furniture door

- Use 2 screws to fix.

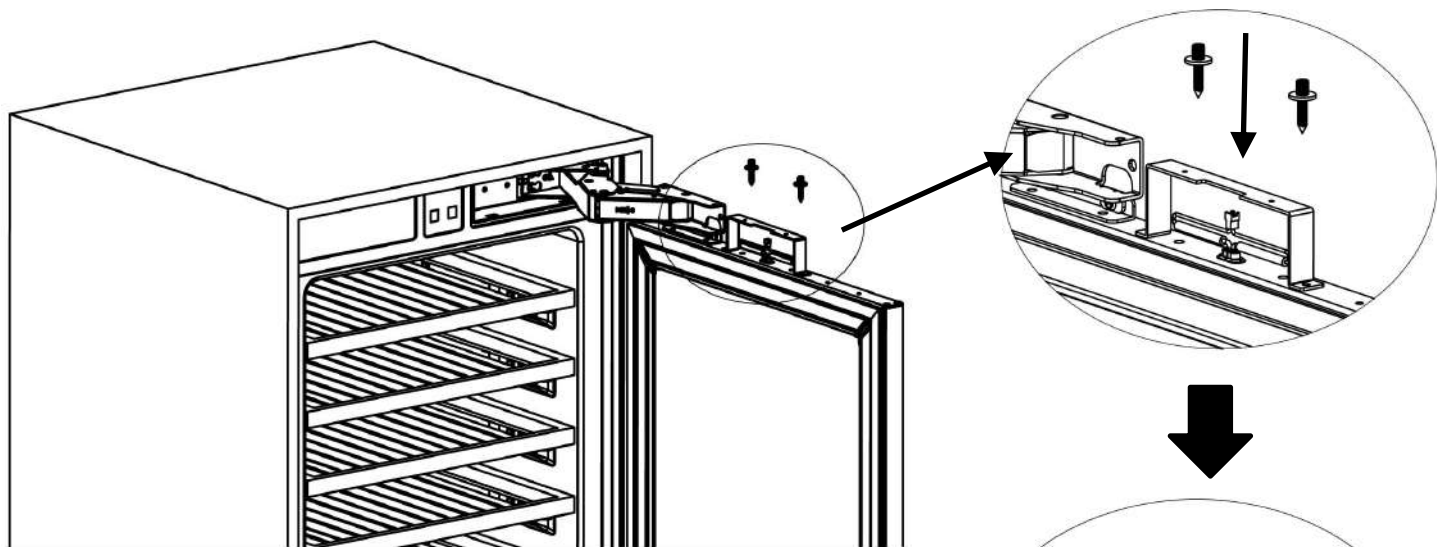

- Attach the furniture door to the door

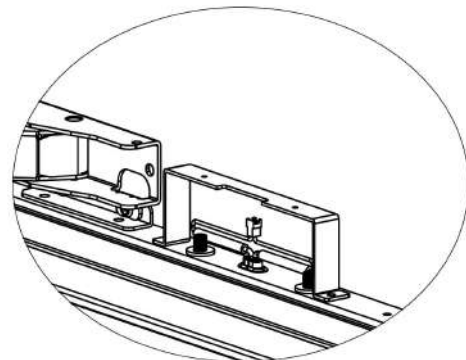
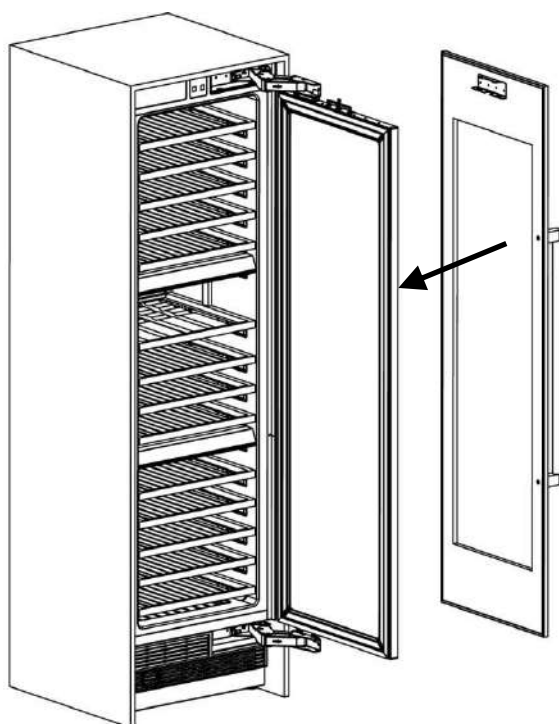

Installation Instructions

- You should adjust 3D direction using by two fixing bolt to perform fine adjustments.

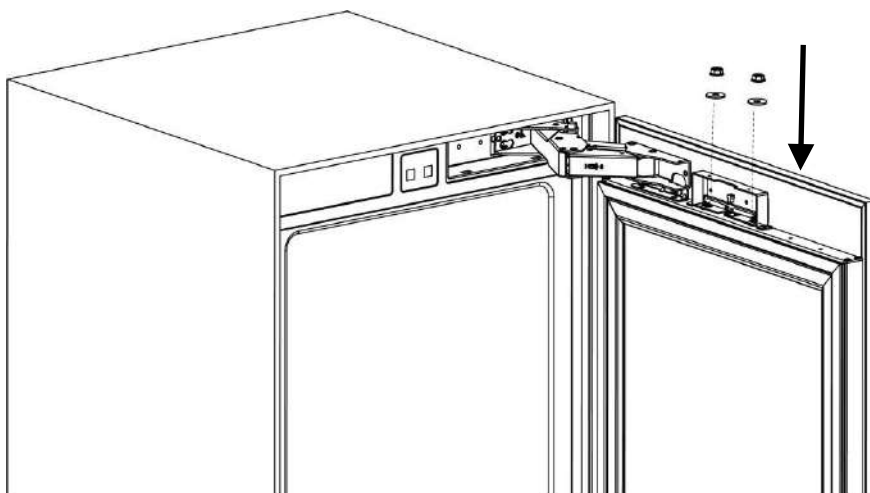

- How to align the furniture door upper part with bolts.

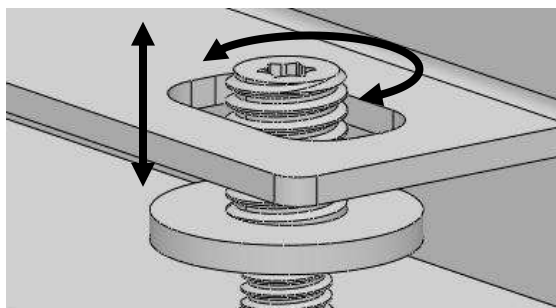

Up & down

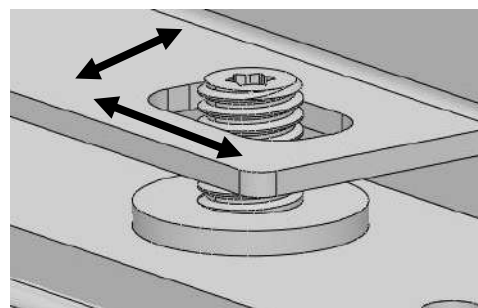

Front & back
Left & right

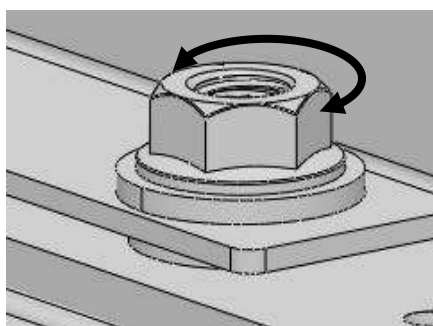

Fixing furniture door completely

Installation Instructions

- Attach and screw the upper decoration cover.

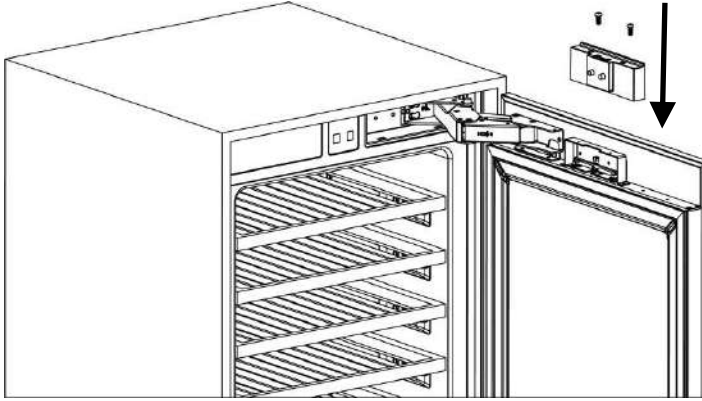

- The left and right are secured by installing screws(ST4x35).

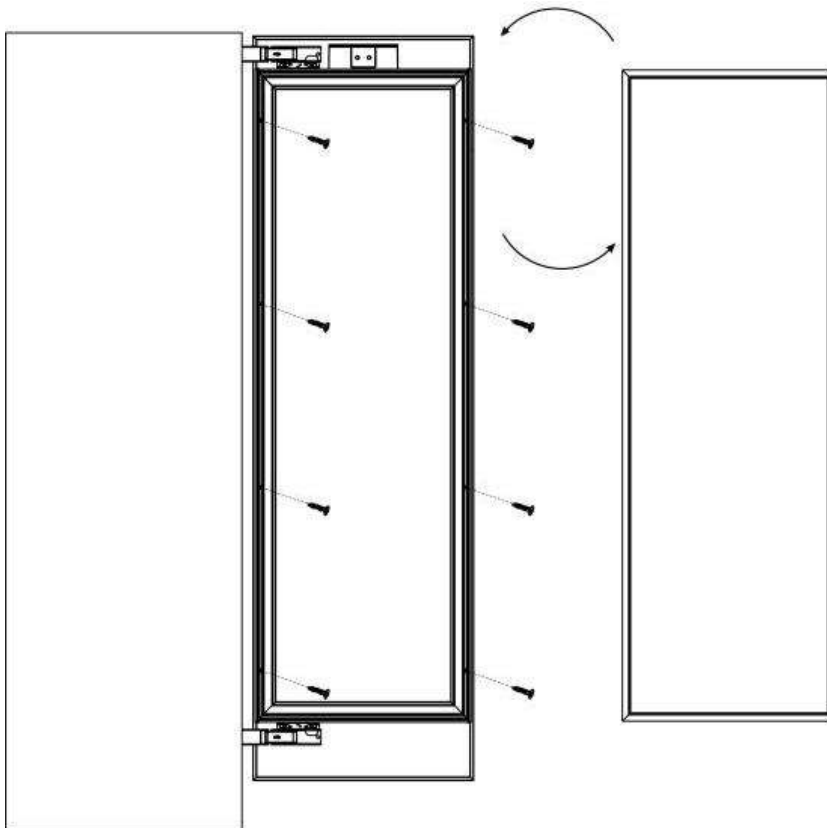

Installation Instructions

Installing the limit pins

- limit pin should be inserted to upper hinge.



The door of your refrigerator can open by 115° maximum.

If the door thickness is more than 1 ½" (38 mm), the door should not open more than 90°.

You must use 90° limit pin on the hinge.

Pin must be fully seated in the bracket or the door will not close properly.

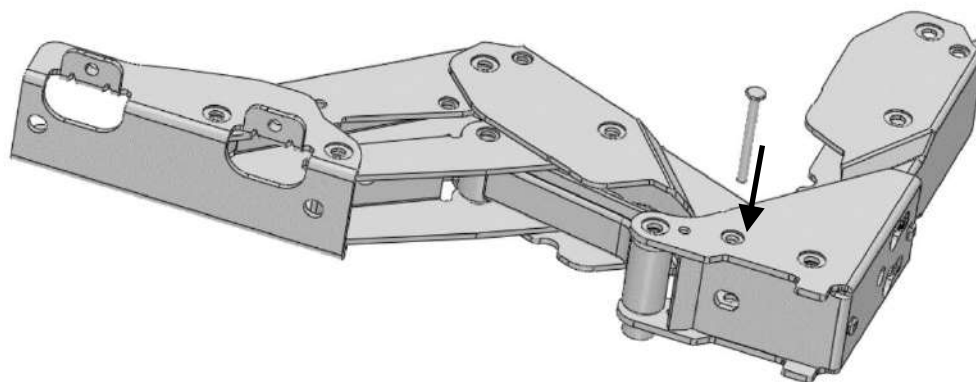

Installation Instructions

Removing the Wooden Shelves

1. Pull the wine rack. Wine rack card slot out of the guide rail fixed column.

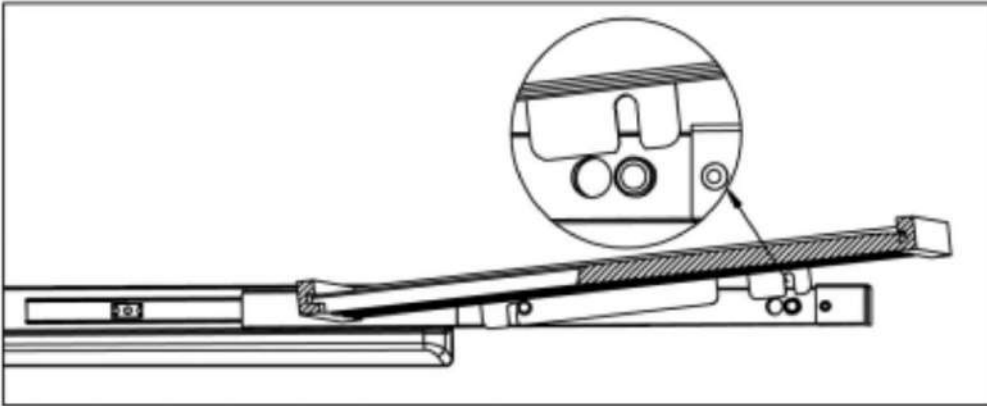

2. Pull the wine rack forward. The guide retaining post is stuck in the position indicated in the figure that the retaining.

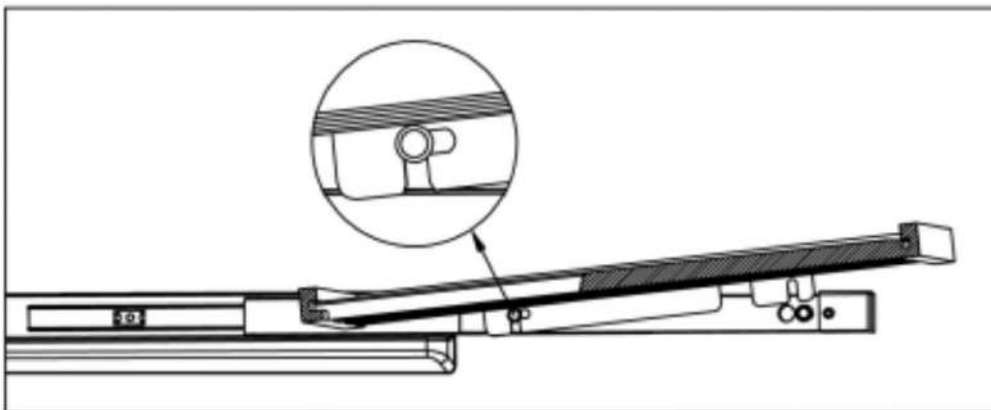

3. Pull the wine rack to remove.

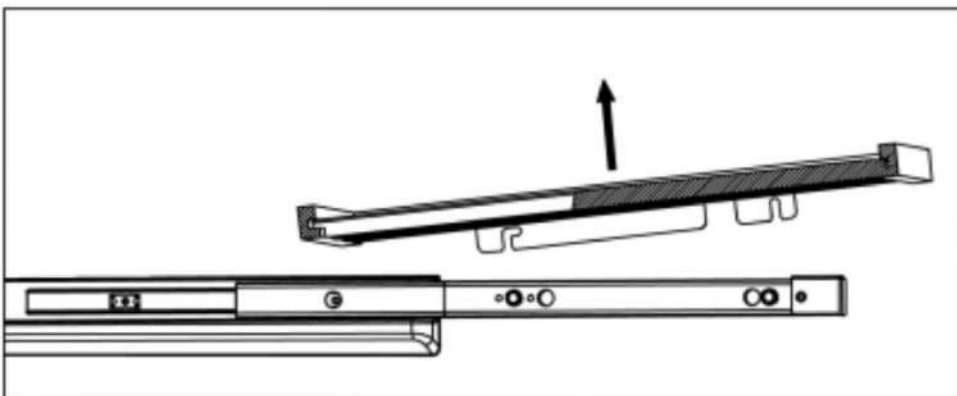













Operating Your Appliance

If the unit is unplugged, power lost, or turned off, you must wait 3 to 5 minutes before restarting the unit. If you attempt to restart before this time delay, the appliance may not start and will not keep the last set temperature.

Using the Control Panel









- | | |
|--------------------|------------------------------|
| ① Power On/OFF | ② Sabbath Mode |
| ③ Upper Zone Temp | ④ Above Zone Temp. Control |
| ⑤ Middle Zone Temp | ⑥ Middle Zone Temp. Control |
| ⑦ Lower Zone Temp | ⑧ below Zone Temp. Control |
| ⑨ Light Switch | ⑩ Temp. Display Change °C↔°F |

- Child lock key ( + ): power on the default unlocked state; if you need to lock, you need to press ( + ), manual locking, such as the need to unlock, press ( + ) to unlock; lock, press any key,  the box within the three temperature zones of the temperature value of the digital screen at the same time blinking for 3 seconds, accompanied by beeping to suggest that in the locking state;
- On/Off key : Long press "  " for 3s to turn on or turn off the power; when shutting down, cut off the power of all peripherals and enter standby mode;
- LED lighting button : LED lighting controlled by the door switch, open the door light, Close the door light off; short press "  " to realize the LED lighting red, blue, white, off the light cycle between switching, memory of the last state (off the state of the light is not memorized); long press "  " 3 seconds to realize the light is always on, at the same time,

Operating Your Appliance

the digital screen of the three temperature zones are displayed ON for 5 seconds, 5 seconds after the digital screen to restore the temperature value display; in the

digital screen display ON state, the key  can be adjusted up and down to adjust the brightness of the LED lighting, L1 ~ L7 cycle of adjustment, a total of 7 levels, L7 is the brightest, the memory of the last time state;

- Open and close the door control: when the door is opened, the lighting is turned on, the display is lit and kept until the door is closed, the fan stops, when the door is opened for more than 5 minutes, the open door alarm is opened, and the alarm is canceled by pressing any key; when the door is closed, the lighting is turned off (except for the manual operation of the light), the fan stops the state of lifting and starting immediately, and the door is closed for 30 seconds, and the display is turned off.
- Sabbath on/off key : Short press "  " key to enter or exit Sabbath; after entering Sabbath, the press and fan will run normally, the lighting will go out long time, the display will go out long time, the buzzer will turn off, and the power failure will be memorized, and the power failure will be automatically exited after 96 hours of operation, and the failure will also be automatically exited; if you need to exit manually, press "  " key to exit the Sabbath mode, and after exiting, it will run in normal mode;he
- Show room mode: Enter the Showroom mode: Under the power off status, long press ( + ) key for 3 seconds, enter the Show room mode, and the display panel will have "SN" word to indicate.
Under the showroom mode, the compressor will not work, meanwhile, other functions will normally work. The showroom mode will not quit if power shut down, and the mode will automatically quit after 72 hours.
Quit the Show room mode, under the power off status, press the ( + ) key again for 3 seconds, exit the Show room mode.

Operating Your Appliance

NOTE

When you change the temperature on the panel, the panel displays the current temperature and the temperature on the display will gradually change according to the internal temperature until it reaches the desired temperature. Note that it will take time for the wine cellar to reach the new temperature. This is normal. You do not need to set the desired temperature just because the display does not show your desired temperature.

If the control panel has moisture or liquid on its surface, it may fail. Wipe the moisture or liquid using a dry cloth, and then try again.

Power failure memory function

(after power-on, the Settings remain in the state before power failure)

UPPER ZONE Temperature: 5-20°C (41°F - 68°F)

MIDDLE ZONE Temperature: 5-20°C (41°F - 68°F)

OWER ZONE Temperature: 5-20°C (41°F - 68°F)

Operating Your Appliance

Trouble Code

When a malfunction occurs, contact a service technician for repairs

Explanation	Open Circuit Code	Short Circuit Code
Above Zone In-cabinet probes	E1	E2
Above Zone Frosting probe	E3	E4
Middle Zone In-cabinet probe	E5	E6
Middle Zone Frosting probe	E7	E8
Above Zone In-cabinet probes	E9	E10
Below Zone Frosting probe	E11	E12

NOTE

1. When there is a fault code, the buzzer will emit "Tick" "Tick" "Tick" three consecutive alarm sounds, the fault code flashes, every 10 seconds for a cycle, and the alarm will be activated .if you want to release the alarm sound.
If you want to release the alarm sound, press the on/off key.
2. Whenever a key is pressed, the buzzer sounds "Tick".

Defrosting

The wine cooler is designed with an automatic defrost system. However, on colder settings, some frost may build up. Additionally, the more humid the ambient conditions, the more frost may build up. Keep the door closed as much as possible and avoid opening the door unnecessarily to minimize frost build-up.

If frost is preventing the door from closing properly, you may need to power the unit **off** until the frost melts (possibly up to 24 hours). Use a soft absorbent towel to dry the unit.



Care And Maintenance

Normal Sounds

Your new wine cooler may make sounds that are not familiar to you. Most of the new sounds are normal. Hard surfaces like the floor or walls can make the sounds seem louder than they actually are. The following describes the kinds of sounds that might be new to you and what may be making them.

- ▶ Rattling noises may come from the flow of the refrigerant or the water line.
- ▶ Items stored on top of the wine cooler can also make noises.
- ▶ The high efficiency compressor may make a pulsating or high-pitched sound.
- ▶ Water running from the evaporator to the water bin may make a splashing sound.
- ▶ As each cycle ends, you may hear a gurgling sound due to the refrigerant flowing in your beverage cooler.
- ▶ You may hear air being forced over the condenser by the condenser fan.

Cleaning the Unit

Periodic cleaning and proper maintenance will ensure efficiency, top performance, and long life.

Interior Cleaning

1. Disconnect power to the unit.
2. Open the door and remove the contents and shelves.
3. With a clean cloth, wipe down the interior of the unit.
4. Reinsert the shelves and beverages.
5. Reconnect power to the unit.

Exterior Cleaning

The door and cabinet may be cleaned with a mild detergent and lukewarm water solution such as two (2) tablespoons of baking soda to one (1) quart of water. Do not use solvent based or abrasive cleaners. Use a soft sponge and rinse with clean water. Wipe with a soft clean towel to prevent water spotting. If the door panel is stainless steel, it can discolor when exposed to chlorine gas and moisture. Clean stainless steel with a cloth dampened with a mild detergent and warm water solution. Never use an abrasive or caustic cleaning agent.

Care And Maintenance

Power Failure

Most power failures are corrected within a few hours and should not affect the temperature of your appliance if you minimize the number of times the door is opened. If the power is going to be off for a longer period of time, you need to take the proper steps to protect your contents.

Moving Your Wine Cooler

- ▶ Remove all items.
- ▶ Securely tape down all loose items (shelves) inside your appliance.
- ▶ Turn the adjustable leg all the way up (clockwise) to the base to avoid damage.
- ▶ Tape the door shut.
- ▶ Be sure the appliance stays secure in the upright position during transportation. Also protect outside of appliance with a blanket, or similar item.

Energy Saving Tips

- ▶ The appliance should be located in the coolest area of the room, away from heat producing appliances, and out of the direct sunlight.
- ▶ Ensure that the unit is adequately ventilated. Never cover air vents.
- ▶ Only open the door for as long as necessary.

Troubleshooting

Possible Problem	Possible Cause	Solutions
The appliance does not operate.	Not plugged in.	Ensure the appliance is plugged in and the power outlet has power.
	The appliance is turned off.	Turn on the appliance.
	The circuit breaker tripped or has a blown fuse.	Replace the broken fuse or reset the breaker.
The appliance is not cold enough.	Temperature control setting is too high.	Adjust the set temperature.
	External environment may require a higher setting.	Keep the appliance away from sunshine or other heat sources.
	The door is opened too frequently or for long periods of time.	Close the door tightly and do not open the door too frequently or for a long period of time.
	The door gasket is not sealed properly.	Ensure the door gasket is not loose.
	Demonstration mode may be enabled.	See the Operating Your Appliance section and verify if Demonstration mode is disabled.
	The cooler does not have sufficient ventilation.	Read and follow the "Installation Clearance Requirements" in the Installation Instructions section.
	The cooler has restricted air flow due to too much storage.	Open space in the cabinet to allow air flow.
The appliance turns on and off frequently.	The room temperature is hotter than normal.	Run the refrigerator at the appropriate ambient temperature.
	The door gasket is not sealed properly.	Ensure the door gasket is not loose.
	The door is opened too frequently or for long periods of time.	Close the door tightly and do not open the door too frequently or for a long period of time.
	The cooler does not have sufficient ventilation.	Read and follow the "Installation Clearance Requirements" in the Installation Instructions section.
	The door is not closed completely	Make sure the door is completely closed.
The body of the appliance is electrified.	The unit is not properly grounded.	Contact your local electrician to test your electrical grounding system.

Troubleshooting

Possible Problem	Possible Cause	Solutions
Frost is forming in the appliance.	The environment is too humid.	The unit uses an 'auto-defrost' system, under certain conditions, manual defrosting may be required. If frost builds up, you can try running the refrigerator on a warmer temperature setting, minimizing the number of times you open the door or unplugging the unit to allow the frost to melt.
	The ambient temperature is too low.	
	The door is being opened too frequently.	
The appliance makes too much noise.	The rattling noise may come from the flow of the refrigerant, which is normal. As each cycle ends, you may hear gurgling sounds caused by the flow of refrigerant in the appliance.	It is normal that as each cooling cycle ends, you may hearing rattling or gurgling sounds caused by the flow of refrigerant in the appliance. The high efficiency compressor may make a pulsating or high pitched sound.
	Contraction and expansion of the inside walls may cause popping and cracking noises.	Some popping or cracking noises are normal. They are caused by expansion and contraction of the inside walls due to temperature changes.
	The unit is not level or is touching another appliance.	Check to make sure the cooler is level and that it is non in contact with another appliance or furniture.
The door will not close properly.	The appliance is not level.	Make sure the appliance is on a level surface.
	The door gasket is not installed correctly.	Make sure the door gasket is properly installed.
	The gasket is dirty.	Clean the door gasket.
	The shelves are out of position.	Install the shelves correctly.

ELICA North America

TWO-YEAR LIMITED WARRANTY

Register your product in

elica.com

and earn a 3rd year of factory warranty, covering all parts plus in-home labor.

TO OBTAIN SERVICE UNDER WARRANTY

Owner must present proof of original purchase date. Please keep a copy of your dated proof of purchase (sales slip) in order to obtain service under warranty.

PARTS AND SERVICE WARRANTY

For the period of two (2) years from the date of the original purchase, Elica will provide free of charge, non consumable parts or components that failed due to manufacturing defects. During these two (2) years limited warranty, Elica will also provide free of charge, all labor and in-home service to replace any defective parts.

WHAT IS NOT COVERED

- Damage or failure to the product caused by accident or act of God, such as, flood, fire or earthquake.
- Damage or failure caused by modification of the product or use of non-genuine parts.
- Damage or failure to the product caused during delivery, handling or installation.
- Damage or failure to the product caused by operator abuse.
- Damage or failure to the product caused by dwelling fuse replacement or resetting of circuit breakers.
- Damage or failure caused by use of product in a commercial application.
- Service trips to dwelling to provide use or installation guidance.
- Light bulbs, metal or carbon filters and any other consumable part.
- Normal wear of finish.
- Wear to finish due to operator abuse, improper maintenance, use of corrosive or abrasive cleaning products/pads and oven cleaner products.
- When the product has not been operated in accordance with the accompanying instructions for use.

WHO IS COVERED

This warranty is extended to the original purchaser for products purchased for ordinary residential use in North America (Including the United States, Guam, Puerto Rico, US Virgin Islands & Canada).

This warranty is non-transferable and applies only to the original purchaser and does not extend to subsequent owners of the product. This warranty is made expressly in lieu of all other warranties, expressed or implied, including, but not limited to any implied warranty of merchantability or fitness for a particular purpose and all other obligations on the part of Elica North America, provided, however, that if the disclaimer of implied warranties is ineffective under applicable law, the duration of any implied warranty arising by operation of law shall be limited to two (2) years from the date of original purchase at retail or such longer period as may be required by applicable law.

This warranty does not cover any special, incidental and/or consequential damages, nor loss of profits, suffered by the original purchaser, its customers and/or the users of the Products.

WHO TO CONTACT

To obtain service under warranty or for any service related question:

- **USA & CANADA - Western Provinces**
ELICA AFTERSALES
888 732 8018
aftersales@elica.com
- **CANADA - Ontario Province**
ELICA AFTERSALES
888 732 8018
aftersales@elica.com
- **CANADA - Quebec & Atlantic Provinces**
ELECTRO-EXPERTS
1 888 915 8888
repartition@electro-experts.com

To ensure prompt after-sales service, when you call we will kindly ask you to provide the following information indicated on the nameplate inside the hood: **hood model, 12 NC and date of purchase on original invoice.** To access the nameplate, all you have to do is remove the grease filters.

12NC: _____

Hood model: _____

Serial No: _____

Date of purchase on original invoice: _____

ELICA North America

GARANTÍA LIMITADA DE DOS AÑOS

Registre su producto en

elica.com

y gane un 3^{er} año de garantía de fábrica que cubre todas las partes además de la mano de obra.

PARA OBTENER SERVICIO DENTRO DE GARANTÍA

El propietario debe presentar su recibo original de la compra. Guarde por favor una copia de su recibo de compra como prueba, para recibir el servicio dentro del periodo de garantía.

PARTES Y GARANTÍA DE SERVICIO

Por el periodo de dos (2) años desde la fecha original de la compra, Elica proveerá, gratuitamente, partes no-consumibles o componentes que hayan fallado debido a defectos de fabricación. Durante estos dos (2) años de garantía limitada, Elica también proveerá gratuitamente, todo el servicio en casa y mano de obra necesaria para reemplazar cualquier parte defectuosa.

QUÉ NO ESTÁ CUBIERTO

- Daños o fallas del producto causados por accidente o actos de Dios, tales como inundaciones incendios o terremotos.
- Daños o fallas causadas por alteración del producto o por el uso de partes no-originales.
- Daños o fallas del producto causados durante la entrega, manejo o instalación.
- Daños o fallas del producto causados por abuso del usuario.
- Daños o fallas del producto causados por reemplazo de fusibles dañados o reseteo de interruptor de circuito.
- Daño o fallas causados por el uso del producto en un ambiente comercial (no doméstico).
- Viajes de servicio para proporcionar orientación de uso o instalación.
- Bombillas, filtros de carbón o metal y cualquier otra parte consumible.
- Desgaste normal.
- Desgaste terminal debido a abusos del usuario, mantenimiento inadecuado, uso de productos / toallas de limpieza corrosivos o abrasivos y por uso de limpiadores para hornos.
- Cuando el producto no hubiese sido operado de acuerdo con el instructivo de uso que se le acompaña.

QUIÉN ESTÁ CUBIERTO

Esta garantía se extiende al comprador original de productos adquiridos para uso residencial en Norte América (incluyendo Estados Unidos, Guam, Puerto Rico, Islas Vírgenes de EU y Canadá).

Esta garantía no es transferible y aplica solamente al comprador original y no se extiende a propietarios subsecuentes del producto. Esta garantía se expresa en lugar de otras garantías, expresadas o implícadas, incluyendo, pero no limitada a ninguna garantía implícada de comercialización o adaptada para propósitos particulares y cualquier otra obligación por parte de Elica North America, considerando, sin embargo, que si la negación de garantías implícitas es inefectiva bajo la ley aplicable, la duración de cualquier garantía implícita será limitada a dos (2) años desde la fecha original de compra o por el periodo necesario como sea requerido por la ley aplicable.

Esta garantía no cubre cualquier daño especial, incidental y/o consecuente, ni pérdidas de ganancias, sufridas por el comprador original, sus clientes y/o usuarios del producto.

A QUIÉN CONTACTAR

Para obtener Servicio bajo Garantía o para cualquier pregunta relacionada a Servicio:
Favor de llamar a:

- **USA & CANADA - Provincias Occidentales**
ELICA AFTERSALES
888 732 8018
aftersales@elica.com
- **CANADA - Provincia de Ontario**
ELICA AFTERSALES
888 732 8018
aftersales@elica.com
- **CANADA - Provincias de Quebec & Atlántico**
ELECTRO-EXPERTS
1 888 915 8888
repartition@electro-experts.com

Para garantizar un rápido servicio postventa, cuando llame le pediremos que amablemente brinde la siguiente información que se indica en la placa de identificación que está dentro de la campana: **modelo de campana, 12 NC y fecha de compra en su factura original**. Para acceder a la placa de identificación, todo lo que tiene que hacer es quitar los filtros de grasa.

12NC: _____

Modelo de campana: _____

No. Serie: _____

Fecha de compra en su factura original: _____

ELICA North America

GARANTIE DE DEUX ANS

Enregistrez votre produit sur

elica.com

et obtenez une 3^e année de garantie, qui couvre toutes les pièces en plus de la main-d'œuvre.

POUR OBTENIR UN DEPANNAGE SOUS GARANTIE

Le propriétaire doit présenter une preuve de la date d'achat. Garder une copie de votre preuve d'achat datée (ticket de caisse) de façon à pouvoir bénéficier du service après-vente sous garantie.

GARANTIE PIÈCES DE RECHANGE ET MAIN D'OEUVRE

Pendant une période de deux (2) ans à partir de la date d'achat, Elica s'engage à fournir gratuitement les pièces de rechange ou les composants autres que les recharges ayant des défauts de fabrication. Durant cette garantie de deux (2) ans, Elica fournira également gratuitement, toute la main d'oeuvre et le service à domicile pour remplacer d'éventuelles pièces défectueuses.

CE QUE LA GARANTIE NE COUVRE PAS

- Dégât ou panne du produit causé par un accident ou un cas de force majeure tels que inondation, incendie ou tremblement de terre.
- Dégât ou panne du produit causé par modification du produit ou utilisation de pièces pas d'origine.
- Dégât ou panne du produit causé lors de la livraison, de la manipulation ou de l'installation.
- Dégât ou panne du produit causé par une mauvaise utilisation.
- Dégât ou panne du produit causé par un remplacement des fusibles ou une remise en fonction des disjoncteurs par le propriétaire.
- Dégât ou panne du produit causé par une utilisation du produit pour raison commerciale.
- Déplacement à domicile pour explication d'utilisation ou d'entretien.
- Ampoules, filtres métalliques ou au charbon et toute autre pièce consommable.
- Usure normale.
- Usure due à une mauvaise utilisation du propriétaire, un entretien incorrect, une utilisation de substances nettoyantes corrosives ou abrasives et produits de nettoyage pour four.
- Lorsque le produit n'a pas été utilisé conformément aux instructions d'utilisation qui l'accompagnent.

QUI EST COUVERT

Cette garantie s'étend à l'acheteur original de produits achetés pour un usage domestique habituel en Amérique du Nord (Y compris Etats Unis, Guam, Porto Rico, les Iles virgins Américaines & le Canada).

Cette garantie n'est pas transférable et vaut uniquement pour l'acheteur original et ne s'étend pas aux propriétaires successifs du produit. Cette garantie vaut expressément en lieu et place de toute autre garantie, expresse ou sous-entendue, mais ne limite pas toute autre garantie sous-entendue de marchandage ou adaptation dans un but particulier et toute autre obligation de la part de Elica North America, étant entendu, cependant, que si la réclamation pour garanties sous-entendues n'est pas applicable aux yeux de la loi en vigueur, la durée de toute garantie sous-entendue émanant de la loi doit être limitée à deux (2) ans à partir de la date d'achat du produit ou à une période plus longue selon ce que dit la loi en vigueur.

Cette garantie ne couvre pas tout dégât particulier, accidentel et/ou consécutif, ni les pertes et profits, à charge du propriétaire, des ses clients et/ou des utilisateurs Des produits.

QUI CONTACTER

Pour obtenir un Service Après-vente durant la Garantie ou pour toute autre Question liée au Service Après-vente: Appeler:

- **USA & CANADA - Provinces de l'Ouest**
ELICA AFTERSALES
888 732 8018
aftersales@elica.com
- **CANADA - Province de l'Ontario**
ELICA AFTERSALES
888 732 8018
aftersales@elica.com
- **CANADA - Québec et provinces de l'Atlantique**
ELECTRO-EXPERTS
1 888 915 8888
repartition@electro-experts.com

Pour garantir un service après-vente rapide, quand vous téléphonerez nous vous prions de bien vouloir donner les informations suivantes, qui sont indiquées sur la plaque signalétique qui se trouve à l'intérieur de la hotte: **modèle, 12 NC et date d'achat sur votre facture originale**. Pour accéder à la plaque signalétique, il vous suffit d'enlever les filtres graisse.

12NC: _____

Modèle: _____

N° de série: _____

Date d'achat sur votre facture originale: _____