







# ASSEMBLY INSTRUCTION

ITEM: 6123-75200-89 Rectangle Dining Table w/2-20in leaves

Thank you for purchasing this quality product. Be sure to unpack carefully looking for small parts which may have come loose during shipment.

Read all instruction and study the drawing carefully before starting the assembly process.

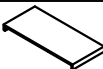
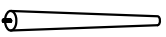
| HARDWARE PACK |   |              |           |       |
|---------------|---|--------------|-----------|-------|
| NO.           | DRAWING   | DESCRIPTION  | SIZE      | Q'TY  |
| A             |  | Allen Wrench | 73*29*5mm | 1 PC  |
| B             |  | Bolt         | 5/16*70mm | 8 PCS |
| C             |  | Lock Washer  | 5/16"     | 8 PCS |
| D             |  | Flat Washer  | 5/16*22mm | 8 PCS |

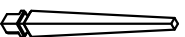
| PARTS LIST |   |             |       |
|------------|---|-------------|-------|
| NO.        | DRAWING   | DESCRIPTION | Q'TY  |
| 1          |  | Table Top   | 1 PC  |
| 2          |  | Leaf        | 2 PCS |
| 3          |  | Center Leg  | 1 PC  |
| 4          |  | LSF Leg     | 2 PCS |
| 5          |  | RSF Leg     | 2 PCS |

**Note:**  
Please follow numbers on legs and corner blocks when assembling legs to table top.

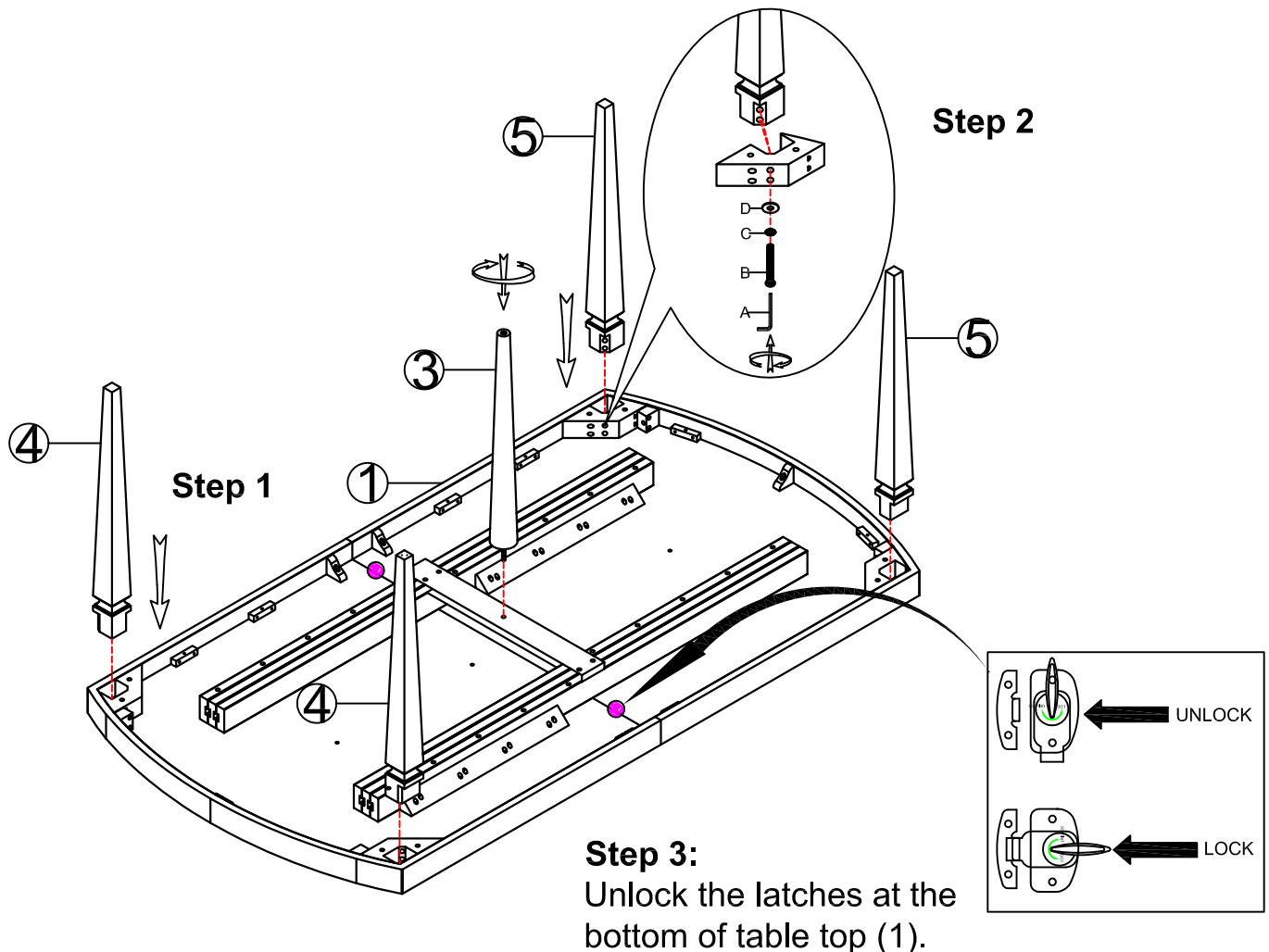

Thank you for purchasing this quality product. Be sure to unpack carefully looking for small parts which may have come loose during shipment.

Read all instruction and study the drawing carefully before starting the assembly process.

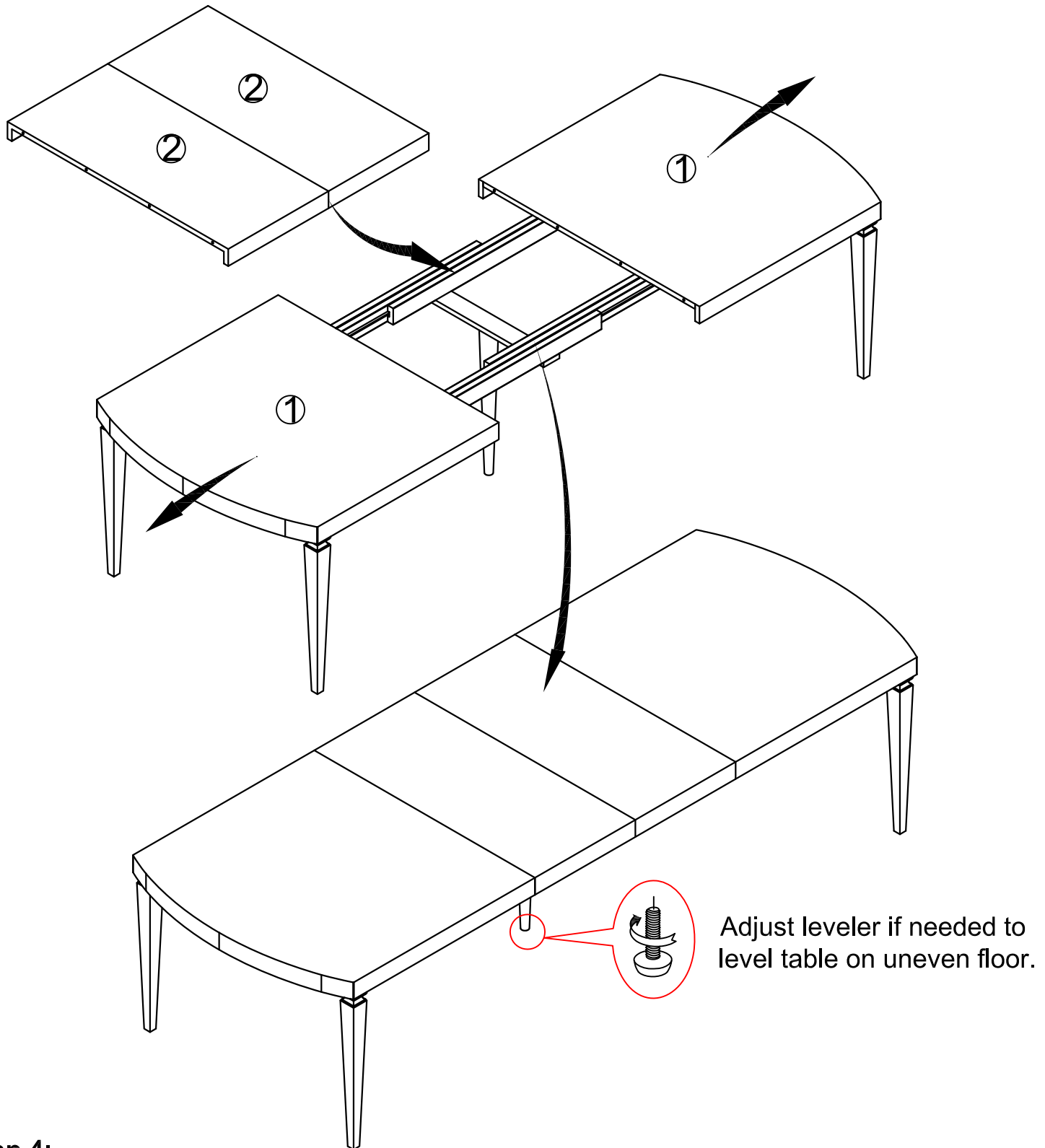
**Step 4:**

Pull out both ends of table top (1) as the arrow direction, place the leaves (2) between and push them together, lock the latches.

Note: Take opposite actions to remove table leaves.