



ASSEMBLY INSTRUCTIONS





Item No : D1248-20
LENNOX UPHOLSTERED SIDE CHAIR
(2PCS PER CARTON)

Thank you for purchasing this quality product. Be sure to check all packing materials carefully for small parts, which may have come loose inside the carton during shipment. Identify and count all items and compare with the parts list and/or hardware list shown below.

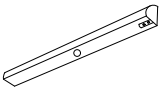
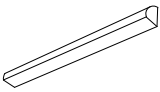
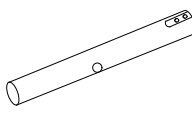
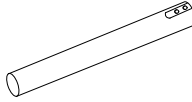
Cautions :

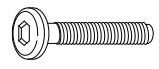
- (1) Do not fully-tighten the nut or nut bolts initially until all nuts or bolt is ready assembled.
(To avoid causing damages to the thread, do not over-tighten the nuts or bolts.)
- (2) Keep all hardware part out of reach of children.

PARTS LIST			
NO	DESCRIPTION	SKETCH	QTY
A	CHAIR BACK		2 PCS
B	STRETCHER		4 PCS
C	LEFT SIDE FACING (LSF) BACK LEG (L)		2 PCS
D	RIGHT SIDE FACING (RSF) BACK LEG (R)		2 PCS
E	LEFT SIDE FACING (LSF) FRONT LEG (L)		2 PCS
F	RIGHT SIDE FACING (RSF) FRONT LEG (R)		2 PCS

HARDWARE LIST			
NO	DESCRIPTION	SKETCH	QTY
1	Bolt M6 x 2-3/8"		16 PCS
2	Spring Washer Ø1/4"		16 PCS
3	Flat Washer Ø1/4" x 3/4"		16 PCS
4	Allen Key M4		1 PC
5	Screw M4 x 1-1/2"		8 PC

WEIGHT CAPACITY	250 pounds (per seat)
-----------------	-----------------------

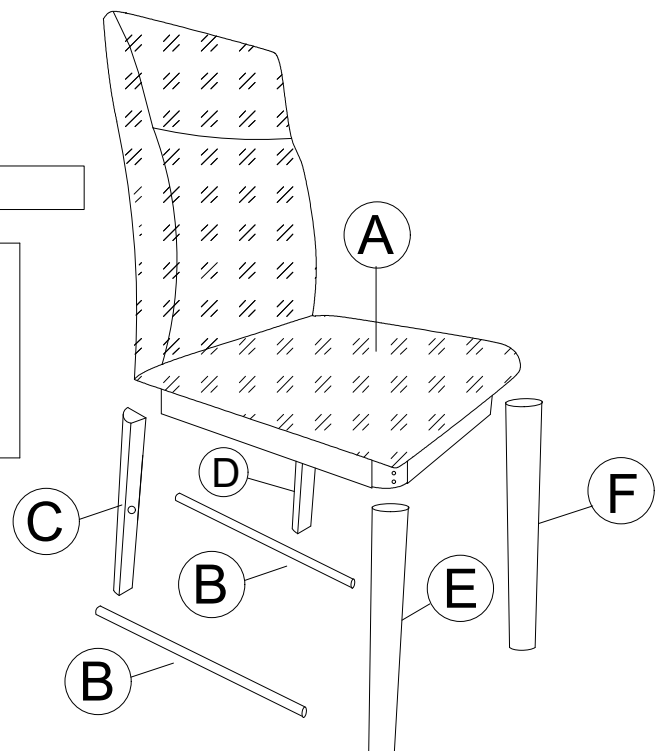
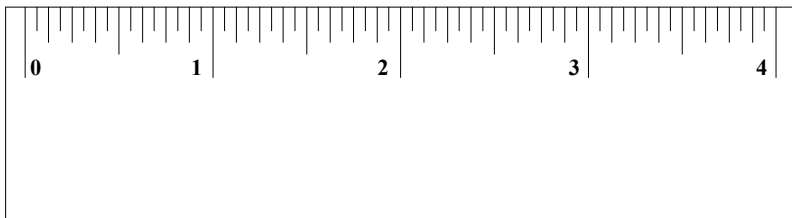

STEP 1 : Place the chair back (A) upside down on flat surface then assemble the back legs (C & D) to the chair back (A) by using the Allen Key (4) with hardware Bolt (1), Spring Washer (2), and Flat Washer (3).

****Attention: DO NOT TIGHTEN THE BOLTS.**

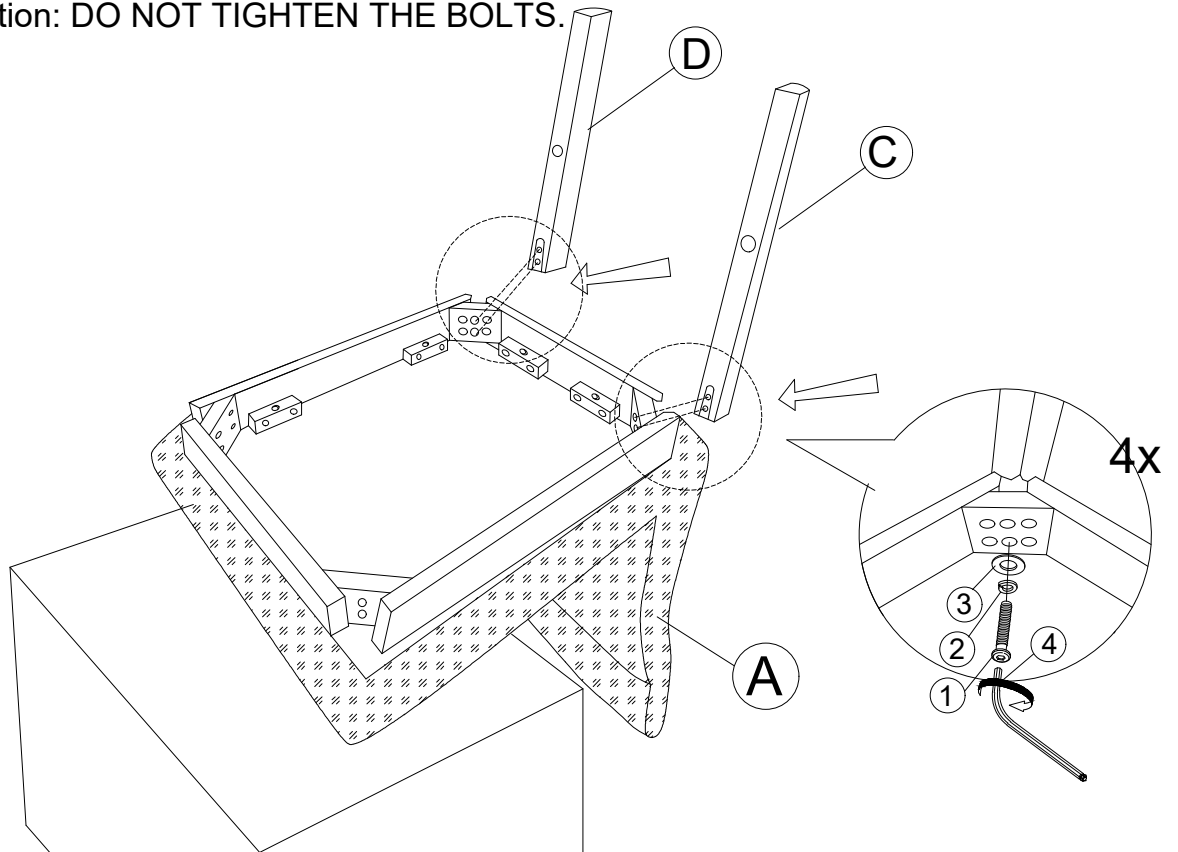

STEP 2 : Position the Stretcher (B) into the back legs (C & D) and the other end into the front legs (E & F). Assemble the the front legs (E & F) to the chair back (A) by using the Allen Key (4) with hardware Bolt (1), Spring Washer (2), and Flat Washer (3).

****Attention: DO NOT TIGHTEN THE BOLTS.**

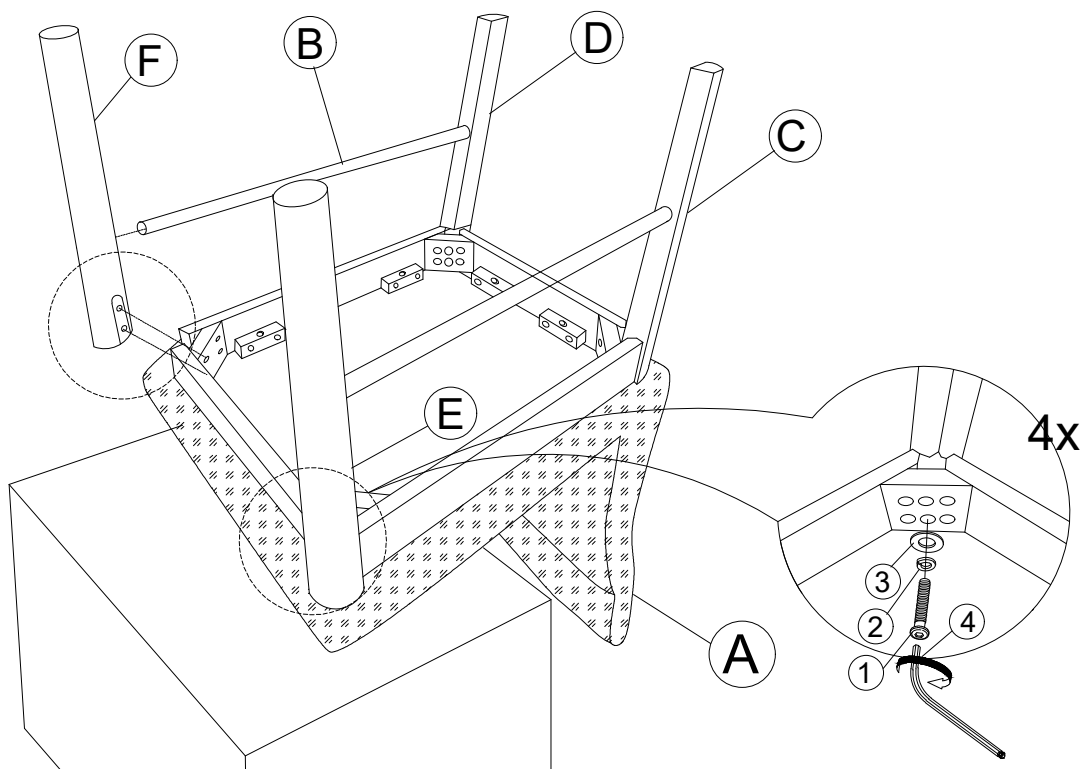

STEP 3 : Assemble the stretcher to the legs by using a screwdriver with hardware Screw (5).
****Attention: DO NOT TIGHTEN THE SCREWS.S**

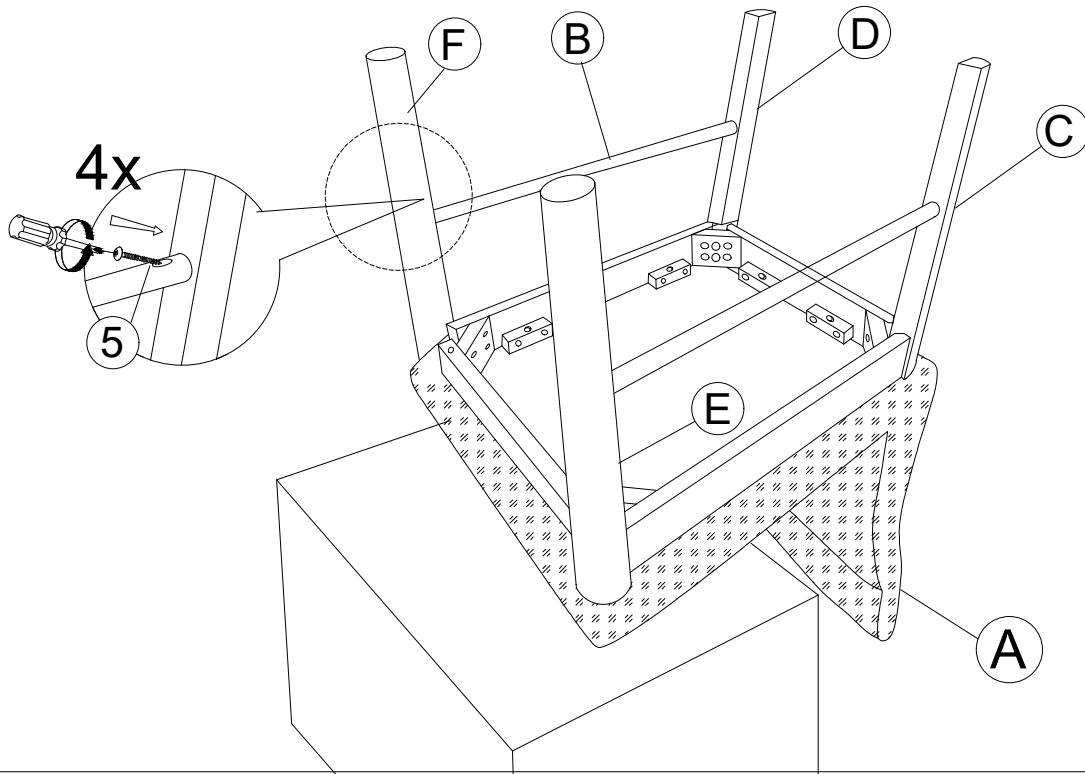

STEP 4 : To level the chair, stand the chair up on a flat surface and tighten all the bolts by using Allen Key (4) and all screws with a screwdriver.

