



HOSHIZAKI

Service Manual

Steelheart Series
Refrigerated Kitchen Equipment

Models
Upright A-Series



hoshizakiamerica.com

Number: 73237
Issued: 2-25-2019
Revised: 3-24-2022

⚠ WARNING

Only qualified service technicians should install and service the appliance. To obtain the name and phone number of your local Hoshizaki Certified Service Representative, visit www.hoshizaki.com. No service should be undertaken until the technician has thoroughly read this Service Manual. Failure to service and maintain the appliance in accordance with this manual will adversely affect safety, performance, component life, and warranty coverage. Proper installation is the responsibility of the installer. Product failure or property damage due to improper installation is not covered under warranty.

Hoshizaki provides this manual primarily to assist qualified service technicians in the service and maintenance of the appliance.

Should the reader have any questions or concerns which have not been satisfactorily addressed, please call, send an e-mail message, or write to the Hoshizaki Technical Support Department for assistance.

Phone: 1-800-233-1940; (770) 487-2331

Fax: 1-800-843-1056; (770) 487-3360

E-mail: techsupport@hoshizaki.com

HOSHIZAKI AMERICA, INC.

618 Highway 74 South

Peachtree City, GA 30269

Attn: Hoshizaki Technical Support Department

Web Site: www.hoshizaki.com

NOTE: To expedite assistance, all correspondence/communication **MUST** include the following information:

- Model Number _____
- Serial Number _____
- Complete and detailed explanation of the problem.

IMPORTANT

This manual should be read carefully before the appliance is serviced. Read the warnings and guidelines contained in this manual carefully as they provide essential information for the continued safe use, service, and maintenance of the appliance. Retain this manual for any further reference that may be necessary.

CONTENTS

Important Safety Information	5
I. General Information	8
A. Construction	8
B. Refrigeration Flow Chart	10
II. Sequence of Operation and Service Diagnosis	11
A. Sequence of Operation Flow Charts	11
1. Refrigerator	11
2. Freezer	12
B. Service Diagnosis	13
1. Refrigerator	15
2. Freezer	19
C. Control Module Check.....	23
D. Thermistor Check	24
E. Diagnostic Tables	25
III. Controls and Adjustments	27
A. Control Module	27
B. Temperature	29
1. Default Settings	29
2. Temperature Setpoint	29
3. Changing the Temperature Display Scale (°F or °C)	29
C. Defrost	30
D. Alarm Safeties	31
E. Safety Devices and Light Control	32
F. Mullion/Perimeter Heater	32
IV. Refrigeration Circuit and Component Service Information.....	33
A. Service for Refrigerant Lines.....	35
B. Component Service Information.....	38
C. Door Reversal	38
V. Maintenance	39
VI. Preparing the Appliance for Periods of Non-Use	40
VII. Disposal.....	41

VIII. Technical Information.....	42
A. Electrical and Refrigerant Data	42
B. Wiring Diagrams.....	43
1. R1A/R2A/F1A-FG/FGCL/FGCR/FS/FSJ/FSL/FSLJ/HG/HS/HSL, PT1A-FG-FG/FS-FS/HS-HS	43
2. RN1A-FS, RT1A-FS-FS.....	44
3. RN2A-FS, RT2A-FS-FS	45
4. PT2A-FG-FG/FS-FS/HS-HS.....	46
5. R3A-FG/FGCL/FGCR/FS/FSCCL/FSCR/HS/HG	47
6. F2A-FG/FS/HG/HS	48
7. F3A-FS/HS	49
8. DT1A-HS	50
9. DT2A-FS/HS.....	51

Important Safety Information

Throughout this manual, notices appear to bring your attention to situations which could result in death, serious injury, damage to the appliance, or damage to property.

⚠ DANGER	Indicates a hazardous situation that, if not avoided, will result in death or serious injury.
⚠ WARNING	Indicates a hazardous situation that, if not avoided, could result in death or serious injury.
NOTICE	Indicates a situation that, if not avoided, could result in damage to the appliance or property.
IMPORTANT	Indicates important information about the use and care of the appliance.

⚠ DANGER

Risk of Fire or Explosion

Flammable Refrigerant Used

- Follow handling instructions carefully in compliance with U.S. government regulations.
- Do not use mechanical devices to defrost.
- Do not puncture refrigerant tubing. Risk of fire or explosion due to puncture of refrigerant tubing; follow handling instructions carefully.
- Component parts shall be replaced with like components.
- Servicing shall be done by factory authorized service personnel to minimize the risk of possible ignition due to incorrect parts or improper service.
- Consult instruction manual / service manual before attempting to install or service this product. All safety precautions must be followed.
- Dispose of properly in accordance with federal or local regulations.
- Do not place any potential ignition sources in or near the appliance.

Risque De Feu Ou D'Explosion

Le Frigorigène Est Inflammable

- Suivre attentivement les instructions de manipulation conformément à la réglementation gouvernementale.
- Ne pas utiliser d'appareils mécaniques pour dégivrer le réfrigérateur.
- Ne pas perforer la tubulure contenant le frigorigène. Risque de feu ou d'explosion si la tubulure contenant le frigorigène est perforée; suivre les instructions de manutention avec soin.
- Les pièces des composants doivent être remplacées par des pièces et accessoires équivalents.
- L'entretien doit être effectué par le personnel de service autorisé par le fabricant afin de minimiser les risques d'inflammation attribuables à l'installation d'une pièce inadéquate ou à la mauvaise exécution du service.
- Consulter le manuel du propriétaire/ guide de réparation avant de tenter une réparation. Toutes les mesures de sécurité doivent être respectées.
- Éliminer conformément aux règlements fédéraux ou locaux.
- Ne placez aucune source d'inflammation potentielle dans ou près de l'appareil.

WARNING

The appliance should be destined only to the use for which it has been expressly conceived. Any other use should be considered improper and therefore dangerous. The manufacturer cannot be held responsible for injury or damage resulting from improper, incorrect, and unreasonable use. Failure to install, operate, and maintain the appliance in accordance with this manual will adversely affect safety, performance, component life, and warranty coverage.

To reduce the risk of death, electric shock, serious injury, or fire, follow basic precautions including the following:

- Only qualified service technicians should install and service the appliance.
- Wear appropriate personal protective equipment (PPE) when servicing the appliance.
- The appliance must be installed in accordance with applicable national, state, and local codes and regulations.
- Appliance is heavy. Use care when lifting or positioning. Work in pairs when needed to prevent injury or damage. Do not lift using the top section or the doors/drawers.
- To reduce the risk of electric shock, do not touch the plug with damp hands.
- Unplug the appliance before servicing.
- The appliance requires an independent power supply of proper capacity. See the nameplate for electrical specifications. Failure to use an independent power supply of proper capacity can result in a tripped breaker, blown fuse, damage to existing wiring, or component failure. This could lead to heat generation or fire.

• **THE APPLIANCE MUST BE**

GROUNDING. The appliance is equipped with a NEMA 5-15 three-prong grounding plug  to reduce the risk of potential shock hazards. It must be plugged into a properly grounded, independent 3-prong wall outlet. If the outlet is a 2-prong outlet, it is your personal responsibility to have a qualified electrician replace it with a properly grounded, independent 3-prong wall outlet. Do not remove the ground prong from the power cord and do not use an adapter plug. Failure to follow these instructions may result in death, electric shock, or fire.

- Do not use an extension cord.
- Do not use an appliance with a damaged power cord. The power cord should not be altered, jerked, bundled, weighed down, pinched, or tangled. Such actions could result in electric shock or fire. To unplug the appliance, be sure to pull the plug, not the cord, and do not jerk the cord.
- The GREEN ground wire in the factory-installed power cord is connected to the appliance. If it becomes necessary to remove or replace the power cord, be sure to connect the power cord's ground wire.
- Do not splash, pour, or spray water directly onto or into the appliance. This might cause short circuit, electric shock, corrosion, or failure.
- Do not make any alterations to the appliance. Alterations could result in electric shock, injury, fire, or damage to the appliance.
- The appliance is not intended for use by persons (including children) with reduced physical, sensory, or mental capabilities, or lack of experience and knowledge, unless they have been given supervision or instruction concerning use of the appliance by a person responsible for their safety.

⚠ WARNING, continued

- Children should be properly supervised around the appliance.
- Do not climb, stand, or hang on the appliance or doors or allow children or animals to do so. Do not climb into the appliance or allow children or animals to do so. Death or serious injury could occur or the appliance could be damaged.
- Be careful not to pinch fingers when opening and closing the doors or when handling food pans. Be careful when opening and closing the doors when children are in the area.
- Open and close the doors with care. Opening the doors too quickly or forcefully may cause injury or damage to the appliance or surrounding equipment.
- Do not use combustible spray or place volatile or flammable substances in or near the appliance. They might catch fire.
- Keep the area around the appliance clean. Dirt, dust, or insects in the appliance could cause harm to individuals or damage to the equipment.
- Do not throw anything onto the shelves or load any single shelf with more than 120 lb. (54.5 kg) of product. They might fall off and cause injury.
- The appliance is designed only for temporary storage of food. Employ sanitary methods. Use for any other purposes (for example, storage of chemicals or medical supplies such as vaccine and serum) could cause deterioration of stored items.
- Do not place any product on the floor of the cabinet. All product must be placed on properly installed shelves.
- Do not block air inlets or outlets, otherwise cooling performance may be reduced.
- Do not tightly pack the cabinet. Allow some space between items to ensure good air flow. Also allow space between items and interior surfaces.

⚠ WARNING, continued

- Do not put warm or hot foods in the cabinet. Let them cool first, or they will raise the cabinet temperature and could deteriorate other foods in the cabinet or overload the appliance.
- Food storage and handling must comply with applicable codes and regulations.
- All foods should be wrapped in plastic film or stored in sealed containers. Otherwise foods may dry up, pass their smells onto other foods, cause frost to develop, result in poor appliance performance, or increase the likelihood of cross-contamination. Certain dressings and food ingredients, if not stored in sealed containers, may accelerate corrosion of the evaporator, resulting in failure.
- Do not store items near air outlets. Otherwise, items may freeze up and crack or break causing a risk of injury or contamination of other food.

NOTICE

- Protect the floor when moving the appliance to prevent damage to the floor.
- Keep ventilation openings, in the appliance enclosure or in the built-in structure, clear of obstruction.
- Do not allow the appliance to bear any outside weight.
- To prevent deformation or cracks, do not spray insecticide onto the plastic parts or let them come into contact with oil.
- To avoid damage to the gasket, use only the door handle when opening and closing.

I. General Information

A. Construction

1. Solid Door Models

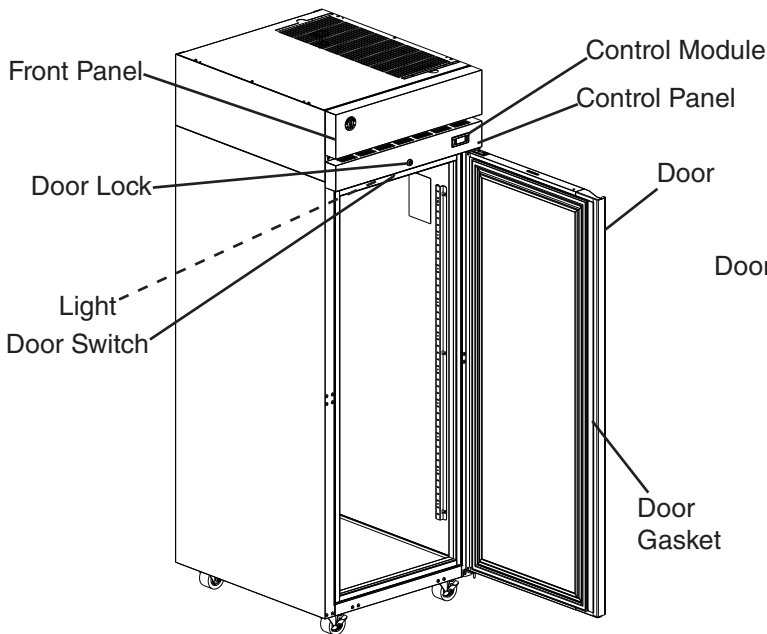
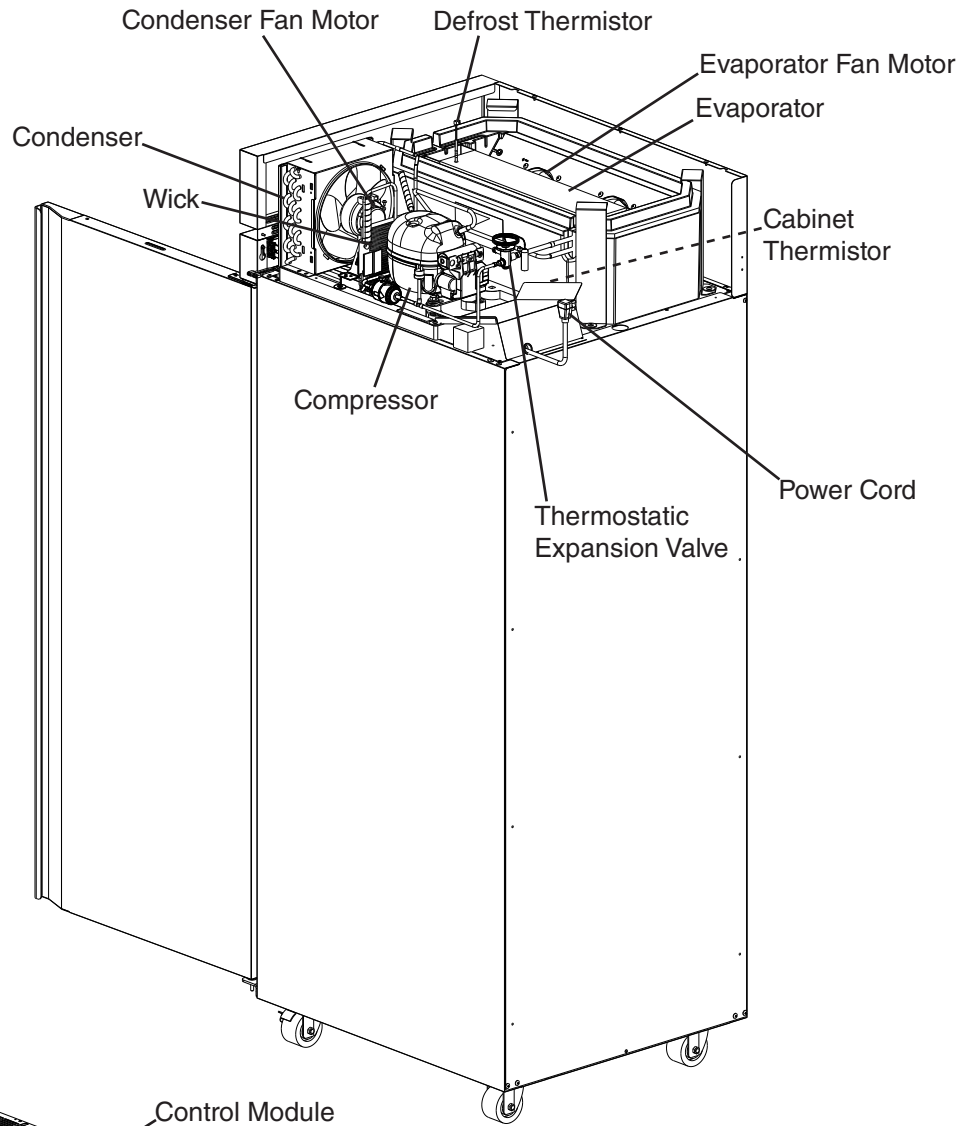

Model Shown: R1A-FS

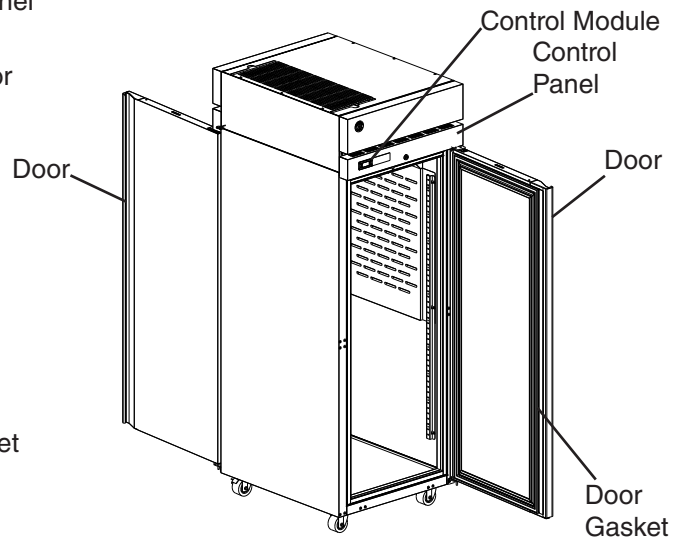

Model Shown: PT1A-FS-FS

2. Glass Door Models

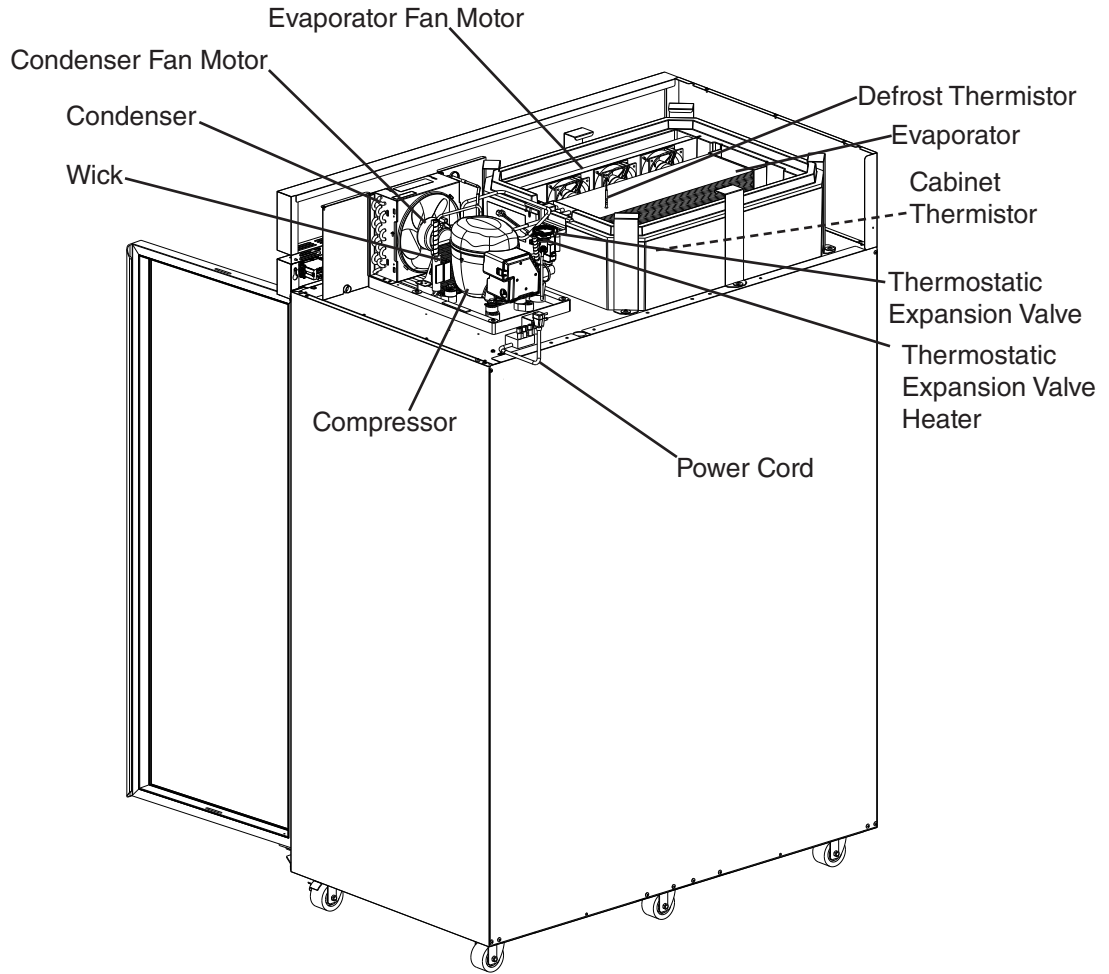

Model Shown: R2A-FG

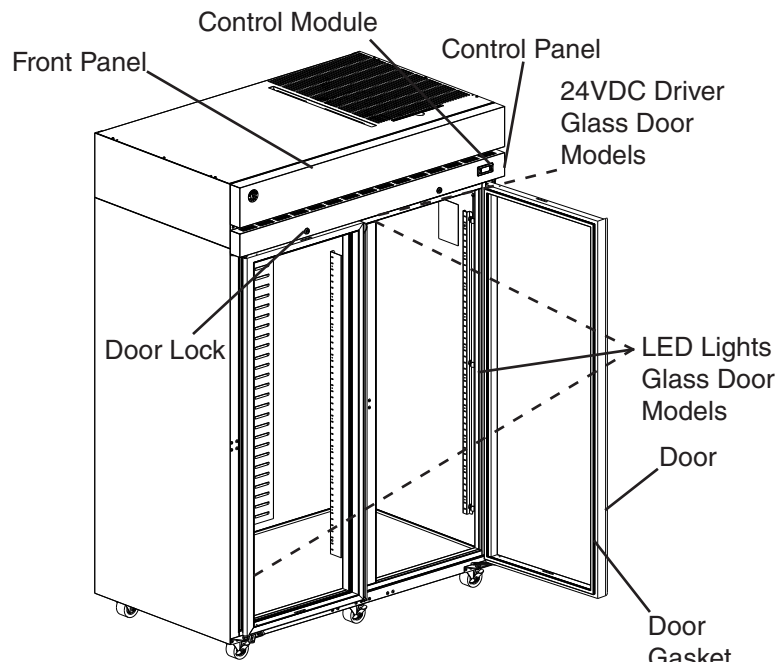

Model Shown: R2A-FG

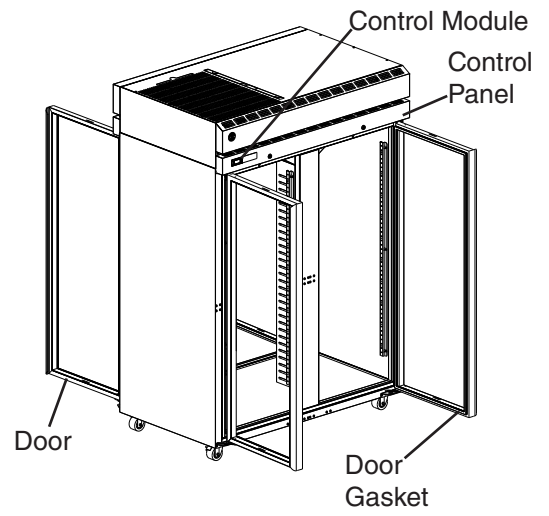

Model Shown: PT2A-FG-FG

B. Refrigeration Flow Chart

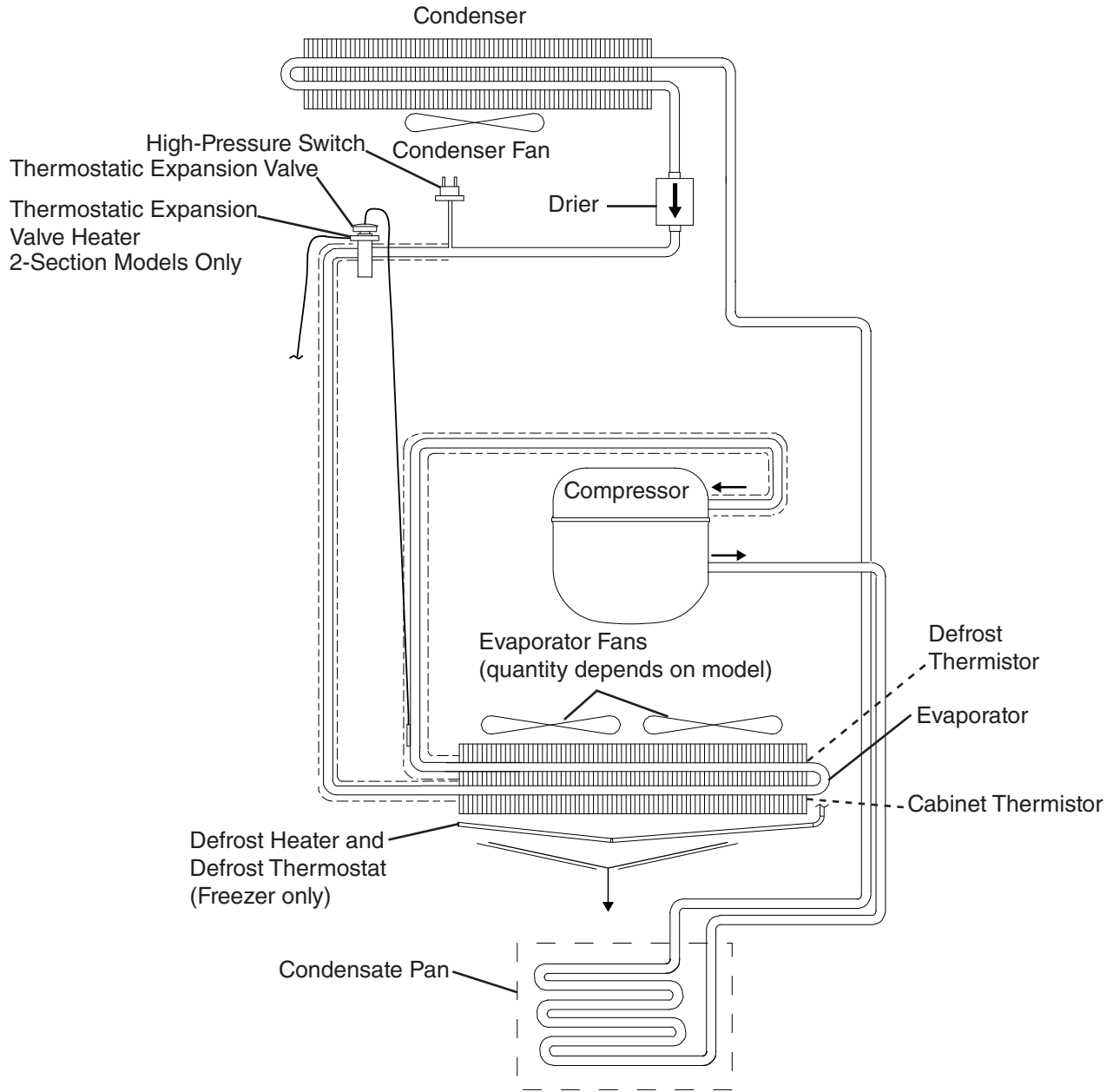

II. Sequence of Operation and Service Diagnosis

A. Sequence of Operation Flow Charts

1. Refrigerator

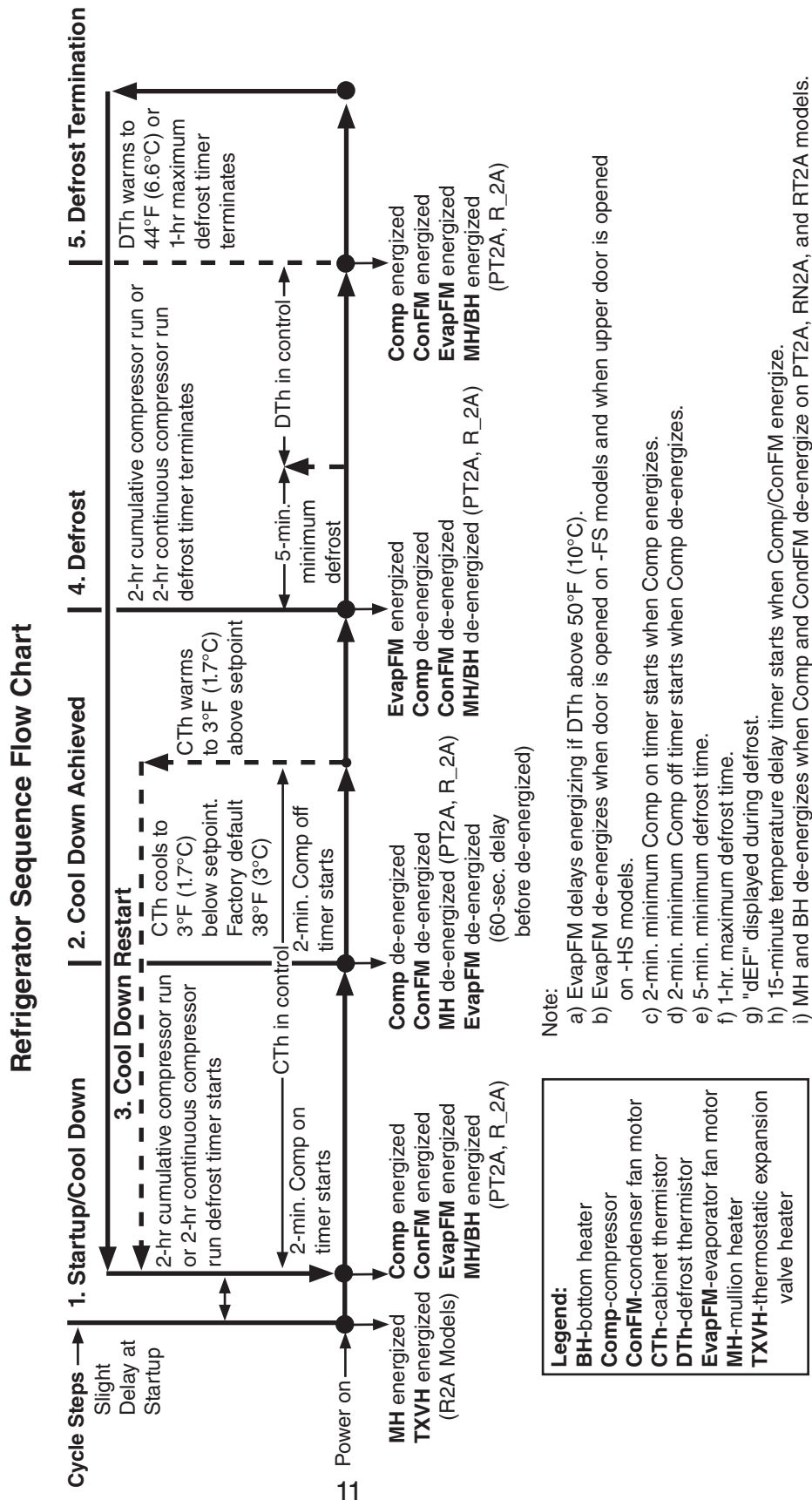

2. Freezer

Freezer Sequence Flow Chart

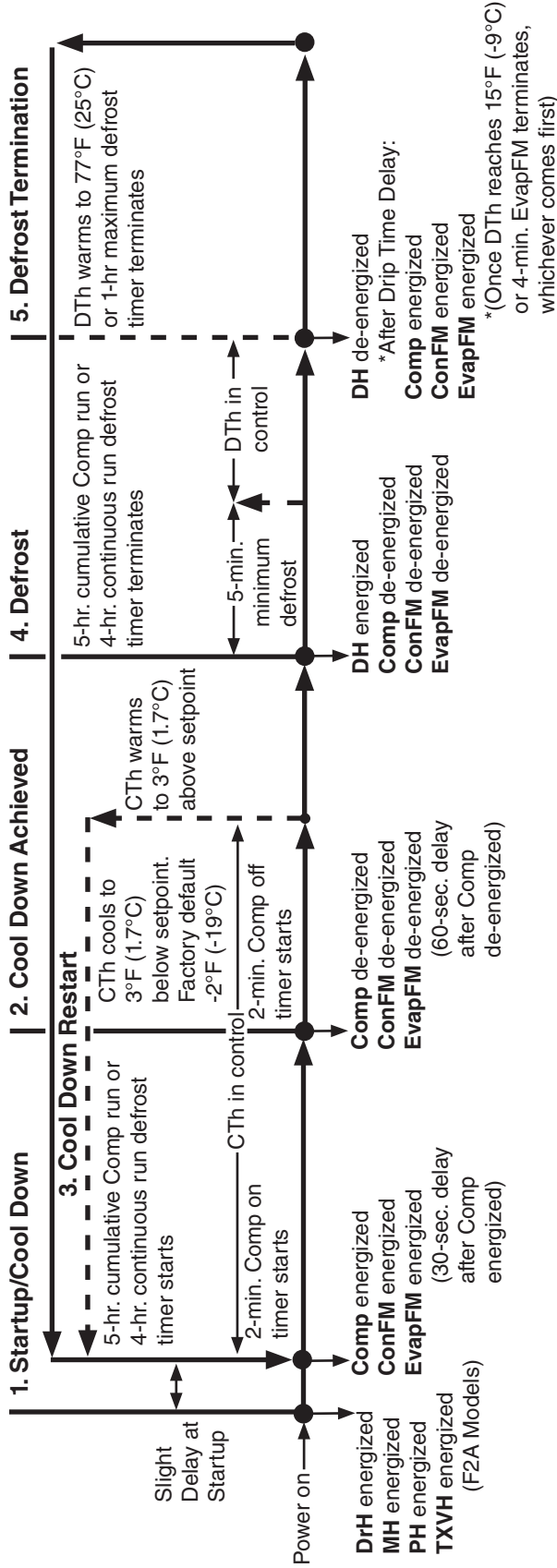

Legend:
Comp-compressor
ConFM-condenser fan motor
CTh-cabinet thermistor
DH-defrost heater
DrH-drain heater
DTh-defrost thermistor
EvapFM-evaporator fan motor
MH-mullion heater
PH-perimeter heater
TXVH-thermostatic expansion valve heater

Note: * Delays

- a) EvapFM delays energizing if DTh above 32°F (0°C).
- b) EvapFM de-energizes when door is opened on -FS models and when upper door is opened on -HS models.
- c) 2-min. minimum Comp on timer starts when Comp energizes.
- d) 2-min. minimum Comp off timer starts when Comp de-energizes.
- e) 5-min. minimum defrost time.
- f) 1-hr. maximum defrost time.
- g) "dEF" displayed during defrost.
- h) 3-min. Comp/ConFM delay timer starts when defrost termination temperature is met.
- i) 4-minute EvapFM delay timer starts when Comp/ConFM delay timer terminates
- j) 15-minute temperature delay timer starts when EvapFM energizes

B. Service Diagnosis

DANGER

Risk of Fire or Explosion

Flammable Refrigerant Used

- Follow handling instructions carefully in compliance with U.S. government regulations.
- Do not use mechanical devices to defrost.
- Do not puncture refrigerant tubing. Risk of fire or explosion due to puncture of refrigerant tubing; follow handling instructions carefully.
- Component parts shall be replaced with like components.
- Servicing shall be done by factory authorized service personnel to minimize the risk of possible ignition due to incorrect parts or improper service.
- Consult instruction manual/service manual before attempting to install or service this product. All safety precautions must be followed.
- Dispose of properly in accordance with federal or local regulations.
- Do not place any potential ignition sources in or near the appliance.

Risque De Feu Ou D'Explosion

Le Frigorigène Est Inflammable

- Suivre attentivement les instructions de manipulation conformément à la réglementation gouvernementale.
- Ne pas utiliser d'appareils mécaniques pour dégivrer le réfrigérateur.
- Ne pas perforer la tubulure contenant le frigorigène. Risque de feu ou d'explosion si la tubulure contenant le frigorigène est perforée; suivre les instructions de manutention avec soin.
- Les pièces des composants doivent être remplacées par des pièces et accessoires équivalents.
- L'entretien doit être effectué par le personnel de service autorisé par le fabricant afin de minimiser les risques d'inflammation attribuables à l'installation d'une pièce inadéquate ou à la mauvaise exécution du service.
- Consulter le manuel du propriétaire/ guide de réparation avant de tenter une réparation. Toutes les mesures de sécurité doivent être respectées.
- Éliminer conformément aux règlements fédéraux ou locaux.
- Ne placez aucune source d'inflammation potentielle dans ou près de l'appareil.

WARNING

- The appliance should be diagnosed and repaired only by qualified service personnel to reduce the risk of death, electric shock, serious injury, or fire.
- Wear appropriate personal protective equipment (PPE) when servicing the appliance.
- Risk of electric shock. Use extreme caution and exercise safe electrical practices.
- Moving parts (e.g., fan blade) can crush and cut. Keep hands clear.
- Appliance is heavy. Use care when lifting or positioning. Work in pairs when needed to prevent injury or damage.
- Make sure all food zones are clean after the appliance is serviced.

NOTICE

- This appliance is not intended for outdoor use.
- Normal operating ambient temperature:
 - Refrigerators and Solid Door Freezers 45°F to 100°F (7°C to 38°C)
 - Glass Door Freezers 45°F to 80°F (7°C to 27°C)Operation of the appliance, for extended periods, outside of this normal temperature range may affect appliance performance.
- The appliance must not be located next to ovens, grills, or other high heat producing equipment.
- The appliance must not be located in a corrosive environment.
- Minimum Clearance:

Models	Side	Top	Rear
Refrigerators and Freezers (Except 2-Section Freezers)	0" (0 cm)	0" (0 cm)	3" (8 cm)
2-Section Freezers	0" (0 cm)	10" (25 cm)	3" (8 cm)

The diagnostic procedure is a sequence check that allows you to diagnose the electrical system and components. Before proceeding, check for correct installation and proper voltage per nameplate. Always choose a neutral (W) to establish a good neutral connection when checking high voltages. If the display is in alarm, see "III.D. Alarm Safeties."

IMPORTANT

The maximum allowable voltage variation is ± 10 percent of the nameplate rating. 115VAC is used as a reference voltage when checking voltage to components. Voltage may vary depending on power supply.

1. Factory Default Settings:

a) Temperature Setpoint:

Model	Auxiliary Code	Temperature Setpoint
Refrigerator	All	38°F (3°C)
Freezer	All	-2°F (-19°C)

b) Temperature Display Scale: °F.

For further details, see "II.C. Control Module Check" or "III. Controls and Adjustments."

- There is a minimum 2-min. Comp on time and 2-min. Comp off time.
- 1) Unplug the appliance from the electrical outlet.
 - 2) Remove the front panel.
 - 3) Plug the appliance back into the electrical outlet.
 - 4) Confirm 115VAC at CM 2 (L) (BK) to neutral (W).

1. Refrigerator

- 5) **Startup/Cool Down**—MH, PH, and TXVH energize. There is a slight delay, Comp, ConFM, and EvapFM energize. On PT2A and R_2A, MH and BH also energize. Cabinet temperature appears on display and 2-hr. defrost timer starts. Note: If DTh is above 50°F (10°C) EvapFM is de-energized.
- a) **MH Diagnosis:** MH energizes at startup (except PT2A). If 115VAC is present, check amp draw of MH. If an amp reading is not present, check the continuity of MH. If defective, replace MH. Note: MH energizes and de-energizes with Comp and CondFM on PT2A and R_2A models.
 - b) **BH Diagnosis:** BH energizes at startup on R_1A and with Comp on R_2A. If 115VAC is present, check amp draw of BH. If an amp reading is not present, check the continuity of BH. If defective, replace BH. Note: BH energizes and de-energizes with Comp and CondFM on R_2A models.
 - c) **TXVH (if applicable) Diagnosis:** Confirm amp draw of TXVH. If no amp draw available, check for 115VAC at TXVH grey wire (GY) to neutral (W). If 115VAC is not present, check wiring connections to TXVH. If 115VAC is present, check TXVH continuity. If open, replace TXVH.
 - d) **EvapFM Diagnosis:** Confirm that EvapFM(s) energize. If not, confirm DTh is at 50°F (10°C) or lower, doors are closed and DS engaged, check DS continuity. If DTh is above 50°F (10°C), wait for evaporator to cool down. If DS is engaged and contacts are open, replace DS. If DS is engaged and contacts are closed, check for 115VAC at CM 5 (F) dark blue (DBU) wire to neutral white (W) wire. If 115VAC is not present, replace CM. If 115VAC is present, check EvapFM blades for binding and EvapFM continuity.
 - e) **Solid Door Cabinet Light Diagnosis:** LED(s) are activated from door switch. Open the door (upper on HS/HG), confirm LED(s) energizes. If not, with door open, check for 5 to 12VDC at CM S4 brown (BR) to CM S4 blue (BU). If 5 to 12VDC is not present at CM S4 brown (BR) to CM S4 blue (BU), confirm 115VAC power supply to CM at terminals 2 (L) black (BK) to 3 (N) white (W). If 115VAC is present, and LED(s) are off, check DS continuity. If DS is disengaged (open) and contacts are closed, replace DS. If DS is disengaged (open) and contacts are open, check for 115VAC from CM 6 (LED) (Y) to a neutral (W). If 115VAC is not present, replace CM. If 115VAC is present at CM 6 (LED) (Y) to a neutral (W) and LED(s) are not on, check for 24VDC at DCD black (BK) wire to DCD red (R) wire. If 24VDC is not present, check continuity of DCD driver. If open, replace DCD driver. If 24VDC is present and LED(s) are not on, check wiring harness and wiring connections from DCD to LED(s). If connections are good and LED(s) are not on, replace LED(s).

- f) **Glass Door Cabinet Light Diagnosis:** LED(s) are activated from control module light switch. Glass door models feature lights that are controlled by the Standby/Light control button located on the control module. Press the standby/light button quickly to turn the light on or off. If LED(s) fail to turn on, check for 115VAC from CM 6 (LED) (Y) to a neutral (W). If 115VAC is not present at CM 6 (LED) (Y) to a neutral (W), replace CM. If 115VAC is present at CM 6 (LED) (Y) to a neutral (W) and LED(s) are not on, check for 24VDC at DCD black (BK) wire to DCD red (R) wire. If 24VDC is not present, check continuity of DCD driver. If open, replace DCD driver. If 24VDC is present and LED(s) are not on, check wiring harness and wiring connections from DCD to LED(s). If connections are good and LED(s) are not on, replace LED(s).
- g) **CM Diagnosis:** Cabinet temperature appears on display. If not, check for 115VAC at CM 2 (L) (BK) to CM 3 (N) (W). If 115VAC is not present, check power cord connections and breaker/fuse. Confirm wiring connections are secure for both CM 2 (L) (BK) (power supply) and CM 3 (N) (W). If 115VAC is present and display is off, replace CM.
- h) **Comp and ConFM Diagnosis:** Confirm Comp and ConFM energize. If not, check for 115VAC at CM 1 (C) (V) to a neutral (W). If 115VAC is not present, check CTh status. See "II.D. Thermistor Check." If CTh ohm reading is in proper range, replace CM. If not in range, replace thermistor. If 115VAC is present at CM 1 (C) (V) to a neutral (W), check for 115VAC at both HPS (V) wires to a neutral (W). If 115VAC is present on one and not the other, check HPS continuity. If open, allow time for HPS to reset. If HPS does not reset, see "i) HPS Activation" below. If HPS is closed and 115VAC present on both HPS (V) wires to a neutral (W), check for 115VAC at condensing unit receptacle and condensing unit power supply cord (BK) to a neutral (W). If 115VAC is not present at condensing unit receptacle or power supply cord (BK), correct loose wiring or replace receptacle or power supply cord. If 115VAC is present at condensing unit power supply cord (BK) and ConFM is energized but Comp is not, check for 115VAC at both Comp external protector wires to a neutral (W). If 115VAC is present on one and not the other, external protector is open. Give external protector time to cool and reset. If Comp external protector does not reset, replace Comp external protector. If 115VAC is present on both Comp external protector wires, check Comp start capacitor, start relay, and Comp motor windings, replace as needed. If Comp does not start, replace condensing unit. If ConFM is not energized, check ConFM fan blades for binding and motor winding continuity.
- If Comp and ConFM are energized and the cabinet does not cool down, check for a restriction in the refrigeration circuit, correct TXV operation, and correct refrigerant charge. See nameplate for correct charge amount.
- i) **HPS Activation:** Confirm ConFM is energized and fan blade turns freely. Confirm condenser coil is not clogged or restricted. Confirm there are no restrictions in the refrigeration circuit (TXV and drier). Let refrigeration circuit pressures equalize. If HPS does not reset and pressures are equalized, replace HPS. If pressures are not equalized, reclaim refrigerant and diagnose refrigeration circuit restriction.

- 6) **Cool Down Achieved**—MH and BH continues (de-energizes on PT2A and R_2A models). CTh cools to 3°F (1.7°C) below setpoint. Comp icon turns off and Comp and ConFM de-energize. EvapFM icon stays on and EvapFM continues. 60-sec. later, EvapFM icon turns off and EvapFM de-energizes.
- a) **Diagnosis:** Confirm Comp icon turns off and Comp, ConFM, and MH (PT2A and R_2A models) de-energize. If not, and Comp and ConFM were energized longer than 2 min., check CTh status. See "I.I.D. Thermistor Check."
 - b) **CM, Comp, ConFM, MH (PT2A and R_2A models), and EvapFM Diagnosis:** If CTh ohm reading is in proper range and Comp, ConFM, and MH continue, check for 115VAC at CM 1 (C) (V) to neutral (W). If 115VAC is present at CM 1 (C) (V), replace CM. 1-min. after Comp icon turns off, confirm EvapFM icon turns off and EvapFM de-energizes. If not, check for 115VAC at CM 5 (F) (DBU) to neutral (W). If 115VAC is present, replace CM.
- 7) **Defrost**—The defrost icon turns on and "dEF" is displayed during defrost. There is a 5-min. minimum defrost time, a 1-hr. maximum defrost time, and a 2-hr. defrost interval. If DTh above 50°F (10°C) at time of defrost, 2-hr. cumulative Comp run and 2-hr. continuous Comp run defrost timers reset and defrost is skipped.
- 1a) **Time-Initiated:** 2-hr. cumulative Comp run or 2-hr continuous Comp run defrost timer terminates (Comp energized more than 2 hrs.). Defrost icon turns on and "dEF" is displayed. Comp icon turns off. Comp, ConFM, and MH (PT2A and R_2A models) de-energize. EvapFM icon stays on and EvapFM continues.
 - 1b) **Manually-Initiated:** To initiate a manual defrost, press the manual defrost button on the display. Defrost icon turns on and "dEF" is displayed. If on, Comp icon turns off. Comp, ConFM, and MH (PT2A and R_2A models) de-energize. EvapFM icon stays on and EvapFM continues.
- 2) **Defrost Termination:**
- (1) DTh warms to 44°F (6.6°C). If not, confirm DTh status. See "I.I.D. Thermistor Check." If DTh is in proper range, Comp icon turns on. Comp, ConFM, and MH (PT2A and R_2A models) energize. Defrost icon, EvapFM icon, and "dEF" continues. EvapFM remains energized.
 - (2) 15-min. temperature display delay timer terminates. Cabinet temperature replaces "dEF" on CM display.

Defrost Diagnosis:

- 1) **Time-Initiation or Manual Initiation:** Time-Initiation; 2-hr. cumulative compressor run or 2-hr continuous compressor run defrost timer terminates. Note; EvapFM remains energized during defrost.
Manual Initiation; CM defrost button pressed.
Note: There is 5-min. minimum defrost time and a 1-hr. maximum defrost time.
 - (1) **CM, Comp, and ConFM Diagnosis:** Confirm defrost icon turns on, "dEF" is displayed, and Comp icon turns off. If not, replace CM. Next, check that CM 1 (C) (V) does not have 115VAC to neutral (W). If 115VAC is present, replace CM.
 - (2) **EvapFM Diagnosis:** Confirm EvapFM icon is on. If not, confirm DTh is below 50°F (10°C). Next, check for 115VAC at CM 5 (F) (DBU) to neutral (W). If 115VAC is not present, replace CM.

2) **Defrost Termination:** DTh warms to 44°F (6.6°C). If not, confirm DTh status. See "II.D. Thermistor Check." If DTh is in proper range, Comp icon turns on and Comp, ConFM, and MH (PT2A and R_2A models) energize. 15-min. temperature display timer starts. Once 15-min. temperature display timer terminates, "dEF" is replaced by cabinet temperature on display.

- (1) **Comp energized:** DTh warms to 44°F (6.6°C), confirm Comp icon turns on and Comp and ConFM energize. If not, confirm cabinet temperature is warm enough for Comp operation. Next, check for 115VAC at CM 1 (C) (V) to neutral (W). If 115VAC is not present, check CTh status. See "II.D. Thermistor Check." If CTh ohm reading is in proper range, Comp icon is on, and 115VAC is not present at CM 1 (C) (V), replace CM. If 115VAC is present, check for 115VAC at CUR (V). If 115VAC is present at CM 1 (C) (V) to neutral (W) and not at CUR (V), check HPS continuity. See "1.5)h) HPS Activation" above. If HPS is closed and 115VAC present, check for 115VAC at condensing unit power supply cord (BK) to neutral (W). If 115VAC is not present at condensing unit power supply cord (BK), replace condensing unit power supply cord. If 115VAC is present at condensing unit power supply cord (BK) and ConFM is energized but Comp is not, check for 115VAC at Comp external protector to neutral (W). If 115VAC is not present, give time for external protector to cool and reset. If Comp external protector does not reset, replace Comp external protector. If 115VAC is present on both Comp external protector wires, check run capacitor, start capacitor, start relay, and Comp motor windings. If ConFM is not energized, check ConFM fan blades for binding and motor winding continuity. If Comp does not start, replace condensing unit.
- (2) **15-min. temperature display delay timer terminates:** 15 min. after Comp icon turns on and Comp and ConFM energize, "dEF" is replaced by cabinet temperature on display. If not, replace CM.

Legend: **BH**—bottom heater; **CL**—cabinet light; **CM**—control module; **Comp**—compressor; **ConFM**—condenser fan motor; **CTh**—cabinet thermistor; **DCD**—direct current driver; **DS**—door switch; **DTh**—defrost thermistor; **EvapFM**—evaporator fan motors; **HPS**—high-pressure switch; **MH**—mullion heater; **TXV**—thermostatic expansion valve; **TXVH**—thermostatic expansion valve heater; **CUR**—condensing unit receptacle

2. Freezer

- 5) **Startup/Cool Down**– MH, PH, DrH, and TXVH energize. There is a slight delay, then Comp, ConFM, and EvapFM energize. Cabinet temperature appears on display and 5-hr. Comp cumulative run time defrost timer starts.
- a) **MH and PH Diagnosis:** PH and MH energize at startup. If 115VAC is present, check amp draw of PH and/or MH. If an amp reading is not present, check the continuity of PH and MH. If defective, replace PH or MH.
 - b) **DrH Diagnosis:** Confirm amp draw of DrH. If no amp draw available, check for 115VAC at DrH black wire (BK) to neutral (W). If 115VAC is not present, check wiring connections to DrH. If 115VAC is present, check DrH continuity. If open, replace DrH.
 - c) **TXVH Diagnosis:** Confirm amp draw of TXVH. If no amp draw available, check for 115VAC at TXVH grey wire (GY) to neutral (W). If 115VAC is not present, check wiring connections to TXVH. If 115VAC is present, check TXVH continuity. If open, replace TXVH.
 - d) **Cabinet Light Diagnosis:** Open the door (upper on HS/HG), confirm CL energizes. If not check for 115VAC at CM 2 (L) (BK) to neutral (W) and CM 6 (Y) (LED) to neutral (W). If 115VAC is not present at CM 2 (L) (BK), confirm power supply. If 115VAC is present at CM 2 (L) (BK), check DS continuity. If DS is disengaged and contacts are closed, replace DS. If DS is de-energized, and 115VAC is not present at CM 6 (Y) (LED) to neutral (W), replace CM. If DS is de-energized and 115VAC is present at CM 6 (Y) (LED) to neutral (W) and LEDs are not on, check for 24VDC at DCD black (BK) 24VDC wire to DCD red (R) 24VDC wire. If 24VDC is not present, check continuity of DCD driver. If open, replace DCD driver. If 24VDC is present and LEDs are not on, check wiring harness and wiring connections from DCD to LED. If connections are good and LEDs are not on, replace LEDs.
 - e) **CM Diagnosis:** Cabinet temperature appears on display. If not, check for 115VAC at CM 2 (L) (BK) to CM 3 (N) neutral (W). If 115VAC is not present, check power cord connections and breaker/fuse. Confirm wiring connections are secure for both CM 2 (L) (BK) (power supply) and CM 3 (N) (W) (neutral). If 115VAC is present and display is off, replace CM.

f) **Comp and ConFM Diagnosis:** Confirm Comp and ConFM energize. If not, check for 115VAC at CM 1 (C) (V) to neutral (W). If 115VAC is not present, check CTh status. See "II.D. Thermistor Check." If CTh ohm reading is in proper range, and 115VAC is not present at CM 1 (C) (V) to neutral (W), replace CM. If thermistor ohm reading is not in range, replace thermistor. If 115VAC is present at CM 1 (C) (V) to neutral (W), check for 115VAC at CUR (V) to neutral (W). If 115VAC is not present, check continuity of HPS. If open, allow time for HPS to reset. If HPS does not reset, see "h) HPS Activation" below. If HPS is closed and 115VAC present, check for 115VAC at condensing unit power supply cord (BK) to neutral (W). If 115VAC is not present at condensing unit power supply cord (BK), replace condensing unit power supply cord. If 115VAC is present at condensing unit power supply cord (BK) and ConFM is energized but Comp is not, check for 115VAC at Comp external protector to neutral (W). If 115VAC is not present, give time for external protector to cool and reset. If Comp external protector does not reset, replace Comp external protector. If 115VAC is present on both Comp external protector wires, check run capacitor (2-Section), start capacitor, start relay, and Comp motor windings. If Comp does not start, replace condensing unit. If ConFM is not energized, check ConFM fan blades for binding and motor winding continuity.

If Comp and ConFM are energized and the cabinet does not cool down, check for a restriction in the refrigeration circuit, correct TXV operation, and correct refrigerant charge. See nameplate for correct charge amount.

g) **EvapFM Diagnosis:** Confirm that EvapFM(s) energizes 30-sec. after startup. If not, confirm DTh is above 32°F (0°C). If above 32°F (0°C), wait for evaporator to cool down. Next, confirm doors are closed and DS engaged, check DS continuity. If DS is engaged and contacts are open, replace DS. If DS is engaged and contacts are closed, check for 115VAC at CM 5 (F) dark blue (DBU) wire to neutral white (W) wire. If 115VAC is not present, replace CM. If 115VAC is present, check EvapFM blades for binding and EvapFM continuity.

h) **HPS Activation:** Confirm ConFM is energized and fan blade turns freely. Confirm condenser coil is not clogged or restricted. Confirm there are no restrictions in the refrigeration circuit (TXV and drier). Let refrigeration circuit pressures equalize. If HPS does not reset and pressures are equalized, replace HPS. If pressures are not equalized, reclaim refrigerant and diagnose refrigeration circuit restriction.

6) **Cool Down Achieved**—PH, MH, and DrH continue. CTh cools to 3°F (1.7°C) below setpoint. Comp icon turns off and Comp and ConFM de-energize. EvapFM icon stays on and EvapFM continues. 60-sec. later, EvapFM icon turns off and EvapFM de-energizes.

a) **Diagnosis:** Confirm Comp icon turns off and Comp and ConFM de-energize. If not, and Comp and ConFM were energized longer than 2 min., check CTh status. See "II.D. Thermistor Check." Replace as needed.

b) **CM, Comp, ConFM, and EvapFM Diagnosis:** If CTh ohm reading is in proper range and Comp continues, check for 115VAC at CM 1 (C) (V) to neutral (W). If 115VAC is present at CM 1 (C) (V), replace CM. 1-min. after Comp icon turns off, confirm EvapFM icon turns off and EvapFM de-energizes. If not, check for 115VAC at CM 5 (F) (DBU) to neutral (W). If 115VAC is present, replace CM.

- 7) **Defrost**—The defrost icon turns on and "dEF" is displayed during defrost. There is a 5-min. minimum defrost time and a 1-hr. maximum defrost time, and a 5-hr. defrost interval.
- 1a) **Time-Initiated:** 5-hr. cumulative Comp run or 4-hr. continuous Comp run defrost timer terminates (Comp energized more than 5 hrs.). Defrost icon turns on and "dEF" is displayed. DH energizes. Comp and EvapFM icons turn off. Comp, ConFM, and EvapFM de-energize.
- 1b) **Manually-Initiated:** To initiate a manual defrost, press the manual defrost button on the display. Defrost icon turns on and "dEF" is displayed. DH energizes. If on, Comp and EvapFM icons turn off. Comp, ConFM, and EvapFM de-energize.
- 2) **Defrost-Termination:**
- (1) DTh warms to 77°F (25°C). If not, confirm DTh status. See "II.D. Thermistor Check." If DTh is in proper range. DH de-energizes. 3 min. Comp delay timer starts. Defrost icon and "dEF" continues.
 - (2) 3 min. Comp delay timer terminates. Comp icon turns on. Comp and ConFM energize. 4-min. EvapFM delay timer starts. Defrost icon and "dEF" continue.
 - (3) 4-min. EvapFM delay timer terminates or the defrost thermistor cools to 15°F (-9°C), EvapFM icon turns on and EvapFM energizes. 15-min. temperature display delay timer starts. Defrost icon turns off, "dEF" continues. Note that the 4-min. EvapFM delay time is a maximum; if the defrost thermistor cools to 15°F (-9°C) before the 4-min. EvapFM delay timer terminates, EvapFM icon turns on and EvapFM energizes. Also, when the cabinet temperature is above 50°F (10°C), EvapFM delays energizing until the cabinet temperature is below 50°F (10°C).
 - (4) 15-min. temperature display delay timer terminates. Cabinet temperature replaces "dEF" on CM display.
Note: Pressing the defrost button on the display terminates defrost. If the cabinet temperature is above setpoint, Comp icon and EvapFM icon turns on and Comp, CondFM, and EvapFM energize.

Defrost Diagnosis:

- 1) **Time-Initiation or Manual Initiation:** Time-Initiation; 5-hr. Comp cumulative run or 4-hr. continuous run defrost timer terminates. Manual Initiation: CM defrost button pressed.
- Note: There is 5-min. minimum defrost time and a 1-hr. maximum defrost time.
- (1) **CM, Comp, CondFM, and EvapFM Diagnosis:** Confirm defrost icon turns on, "dEF" is displayed, and Comp and EvapFM icons turn off. If not, replace CM. Next, check that CM 1 (C) (V) and CM 5 (F) (DBU) do not have 115VAC to neutral (W). If 115VAC is present, replace CM.
 - (2) **DH Diagnosis:** Confirm DH energizes (amp draw). If not, check for 115VAC at CM 4 (H) (R) to neutral (W). If 115VAC is not present and defrost icon is on, replace CM. Next, check for 115VAC at DT (BK) to neutral (W). If 115VAC is not present on both DT black (BK) wires, check DT continuity. If open, let cool and reset. If DT does not close, replace DT. If DT is closed, check DH amp draw and continuity.

- 2) **Defrost-Termination:** DTh warms to 77°F (25°C). If not, confirm DTh status. See "II.D. Thermistor Check." If DTh is in proper range, DH de-energizes and 3-min. Comp delay timer starts. If DTh has not warmed to 77°F (25°C), check DT and DH continuity. Next, check DH amp draw. Once 3-min. Comp delay timer terminates, Comp icon turns on and Comp and ConFM energize. 4-min. EvapFM delay timer starts. Once 4-min. EvapFM delay timer terminates, defrost icon turns off, EvapFM icon turns on and EvapFM energizes. 15-min. temperature display timer starts. Once 15-min. temperature display timer terminates, "dEF" is replaced by cabinet temperature on display.
- (1) **3-min. Comp delay timer terminates:** 3 min. after DH de-energizes, confirm Comp icon turns on and Comp and ConFM energize. If not, confirm cabinet temperature is warm enough for Comp operation. Next, check for 115VAC at CM 1 (C) (V) to neutral (W). If 115VAC is not present, check CTh status. See "II.D. Thermistor Check." If CTh ohm reading is in proper range, Comp icon is on, and 115VAC is not present at CM 1 (C) (V) to neutral (W), replace CM. If 115VAC is present, check for 115VAC at CUR (V) to neutral (W). If 115VAC is present at CM 1 (C) (V) to neutral (W) and not at CUR (V), check HPS continuity. See "2.5)h) HPS Activation" above. If HPS is closed and 115VAC present, check for 115VAC at condensing unit power supply cord (BK) to neutral (W). If 115VAC is not present at condensing unit power supply cord (BK), replace condensing unit power supply cord. If 115VAC is present at condensing unit power supply cord (BK) and ConFM is energized but Comp is not, check for 115VAC at Comp external protector to neutral (W). If 115VAC is not present, give time for external protector to cool and reset. If Comp external protector does not reset, replace Comp external protector. If 115VAC is present on both Comp external protector wires, check run capacitor (Freezer 2-Section), start capacitor, start relay, and Comp motor windings. If ConFM is not energized, check ConFM fan blades for binding and motor winding continuity. If Comp does not start, replace condensing unit.
- (2) **4-min. EvapFM delay timer terminates:**
 Note: The 4-min. EvapFM delay time is a maximum; if the defrost thermistor cools to 15°F (-9°C) before the 4-min. EvapFM delay timer terminates, EvapFM icon turns on and EvapFM energizes. If 15°F (-9°C) is achieved at the defrost thermistor or the 4 min. EvapFM delay timer terminates, confirm EvapFM icon turns on and EvapFM energizes. If not, confirm doors are closed and DS engaged, check DS continuity. If DS is engaged and contacts are open, replace DS. If DS is engaged and contacts are closed, check for 115VAC at CM 5 (F) (DBU) to neutral (W). If 115VAC is not present, replace CM. If 115VAC is present, check EvapFM blades for binding and EvapFM continuity.
- (3) **15-min. temperature display delay timer terminates:** 15 min. after EvapFM icon turns on and EvapFM energizes, "dEF" is replaced by cabinet temperature on display. If not, replace CM.

Legend: **CL**—cabinet light; **CM**—control module; **Comp**—compressor; **ConFM**—condenser fan motor; **CTh**—cabinet thermistor; **DCD**—direct current driver; **DH**—defrost heater; **DrH**—drain heater; **DT**—defrost thermostat; **DTh**—defrost thermistor; **EvapFM**—evaporator fan motors; **HPS**—high-pressure switch; **MH**—mullion heater; **PH**—perimeter heater; **TXV**—thermostatic expansion valve; **TXVH**—thermostatic expansion valve heater; **CUR**—condensing unit receptacle

C. Control Module Check

1. Control Module Display

Before replacing CM that does not show a visible defect and that you suspect is bad, conduct the following check procedure. This procedure will help you verify your diagnosis. Always choose a neutral (W) to establish a good neutral connection when checking high voltages. Also, confirm there is a good power supply and neutral connection to CM: 115VAC at CM 2 (L) (BK) to CM 3 (N) (W).

Alarm Reset: To silence the alarm, press and release the up button with power on.
For alarm information, see "III.D. Alarm Safeties."

2. Startup/Cool Down

- 1) Check all wiring connections. Confirm the CTh, DTh, and DS are properly connected.
- 2) Check for 115VAC at CM 2 (L) (BK) to CM 3 (N) neutral (W). If 115VAC is not present, check power supply and wire connections.
- 3) Check that cabinet temperature is displayed. If not, replace CM.
- 4) Check that Comp and ConFM energize. If not, check CTh status. See "II.D. Thermistor Check." If CTh ohm reading is in proper range, check for 115VAC at CM 1 (C) (V) to neutral (W). If 115VAC is not present, replace CM.
- 5) Check that EvapFM energizes (30-sec. delay on freezers). If not, check for 115VAC CM 5 (F) (DBU) to neutral (W). If 115VAC is not present, make sure DTh is at or below 50°F (10°C). Next, confirm doors are closed and DS engaged. If 115VAC is not present, replace CM.

3. Defrost Initiation

6) Manual Defrost Check:

Refrigerator: Press and release the manual defrost button. Defrost icon turns on and "dEF" is displayed. If energized, Comp icon turns off. EvapFM icon stays on and EvapFM continues.

Freezers: Press and release the manual defrost button. Defrost icon turns on and "dEF" is displayed. DH energizes. If energized, Comp and EvapFM icons turn off. Comp, ConFM, and EvapFM de-energize.

- 7) Confirm Comp, ConFM, and EvapFM (freezers) de-energize. Check for 115VAC at CM 1 (C) (V) to neutral (W) for Comp and ConFM. For freezers, check for 115VAC at CM 5 (F) (DBU) to neutral (W) for EvapFM. If "dEF" is displayed and 115VAC is present, replace CM.
- 8) Freezers: Confirm DH energizes. Check for 115VAC at CM 4 (H) (R) to neutral (W). If "dEF" is displayed and 115VAC is not present, replace CM.

4. Defrost Termination

9) Check that the components restart after defrost termination.

Refrigerator: DTh reaches 44°F (6.6°C). EvapFM icon stays on and EvapFM continues. Comp and ConFM energize. If not, check DTh status. See "II.D. Thermistor Check." If DTh ohm reading is in proper range, and components do not energize, check for 115VAC at CM 1 (C) (V) to neutral (W). If 115VAC is not present, replace CM. If 115VAC is present, check component continuity and replace as needed.

Freezer: DTh reaches 77°F (25°C). DH de-energizes. "dEF" continues on display. 3-min. later, Comp icon turns on and Comp and ConFM energize. EvapFM icon turns on and EvapFM energizes once DTh reaches 15°F (-9°C) or 4-min. EvapFM delay timer terminates. If not, check DTh status. See "II.D. Thermistor Check." If DTh ohm reading is in proper range, and Comp and ConFM, or EvapFM does not energize, replace CM. 15 min. after EvapFM energizes, cabinet temperature appears on CM. If components fail to start, check continuity, replace as needed.

Legend: **CM**—control module; **Comp**—compressor; **ConFM**—condenser fan motor; **CTh**—cabinet thermistor; **DH**—defrost heater; **DS**—door switch; **DTh**—defrost thermistor; **EvapFM**—evaporator fan motors, **MH**—mullion heater; **PH**—perimeter heater

D. Thermistor Check

The cabinet thermistor is used for cabinet temperature control and the defrost thermistor is used for defrost cycle termination and evaporator fan motor control.

- Refrigerator: Defrost termination is 44°F (6.6°C).
- Freezer: Defrost termination is 77°F (25°C).
- Freezer: Evaporator fan motor initiation after defrost is 15°F (-9°C) or 4-min. Evaporator fan motor delay timer terminates.
- Evaporator fan motor high-temperature control:
 - Refrigerator: Defrost thermistor at or higher than 50°F (10°C).
 - Freezer: Defrost thermistor at or higher than 32°F (0°C).

Thermistor resistance varies depending on temperature. The control module monitors the thermistors to control system operation. No adjustment is required.

To check thermistor resistance, follow the steps below.

- 1) Unplug the appliance.
- 2) Remove the front panel, control panel, top louver, and evaporator cover.
- 3) Remove the thermistor in question, then immerse the thermistor sensor portion in a glass containing ice and water for 2 to 3 min.
- 4) Disconnect the thermistor connector from the control module.
- 5) Check the resistance between the wires at the thermistor connector. Normal reading is within 16.0 to 16.7 kΩ. If outside the normal reading, replace the thermistor.
- 6) Reconnect and replace the thermistor in its correct position.
- 7) Replace the evaporator cover, top louver, control panel, and front panel in their correct positions.
- 8) Plug the appliance back in.

E. Diagnostic Tables

Check for correct appliance installation per the instruction manual and proper voltage per appliance nameplate.

1. Not Cooling

Not Cooling - Possible Cause	
1. Power Supply	a) Unplugged, off, blown fuse, tripped or defective circuit breaker.
	b) Loose connection.
	c) Not within specifications.
2. Cord and Plug On three-section model, check receptacle box cord and plug and one-section and two-section cords and plugs.	a) Loose connection.
	b) Defective.
3. Wiring	a) Loose connection.
	b) Faulty.
4. Control Module See "III.D. Alarm Safeties" and "II.C. Control Module Check."	a) In alarm.
	b) Defective.
5. Door Switch	a) Not engaged.
	b) Defective.
6. Evaporator Fan Motor	a) Defective.
7. High-Pressure Switch	a) Dirty condenser.
	b) Ambient temperature too warm.
	c) Condenser fan motor not operating.
	d) Refrigerant overcharge.
	e) Refrigerant lines or components restricted.
	f) Defective.
8. Compressor External Protector	a) Dirty condenser.
	b) Condenser fan motor not operating.
	c) Compressor capacitor or start relay defective.
	d) Defective.
9. Compressor	a) Defective.
10. Condenser	a) Dirty.
11. Evaporator See "2. Evaporator Frozen Up."	a) Clogged or frozen.
12. Refrigerant/Refrigerant Lines	a) Refrigerant leak.
	b) Refrigerant lines restricted.

2. Evaporator Frozen Up

Evaporator Frozen Up - Possible Cause	
1. Evaporator	a) Dirty.
2. Evaporator Fan Motor	a) Fan blades binding.
	b) Defective.
3. Defrost Thermistor	a) Out of position or defective.
4. Control Module	a) Defective.
5. Refrigerant Charge/Refrigerant Lines	a) Low.
	b) Component restriction (TXV, cap tube, drier).
6. Defrost Heater (freezer)	a) Defective.

3. Defrost

Refrigerator Defrost Fails to Initiate - Possible Cause	
1. Control Module (2-hr cumulative compressor run or 2-hr continuous compressor run defrost timer)	a) Defective.
Refrigerator Defrost Fails to Terminate - Possible Cause	
1. Defrost Thermistor (Confirm DTh status. See "II.D. Thermistor Check.")	a) Defrost termination temperature 44°F (6.6°C) not achieved.
	b) Defective.
2. Control Module	a) Defrost thermistor connection loose.
	b) Defective.
Freezer Defrost Fails to Initiate - Possible Cause	
1. 5-hr. cumulative Comp run or 4-hr. continuous run defrost timer terminated	a) Check compressor operation. See "1. Not Cooling."
2. Control Module	a) Defective.
3. Defrost Thermostat	a) Open. Cut-out: 120°F±5°F (49°C±3°C), Cut-in: 70°F±5°F (21°C±3°C)
Freezer Defrost Fails to Terminate - Possible Cause	
1. Defrost Heater	a) Defrost thermostat open.
	b) Defective.
2. Defrost Thermistor (Confirm DTh status. See "II.D. Thermistor Check.")	a) Defrost termination temperature 77°F (25°C) not achieved.
	b) Defrost thermistor connection loose.
3. Control Module	a) Defective.

III. Controls and Adjustments

A. Control Module

All models are pretested and factory set. When plugged into an electrical power supply, there is a slight delay, then the current cabinet temperature is displayed. From the display module, the cabinet setpoint and temperature display scale can be changed.

Note: When exposed to high temperatures, a high-temperature alarm "Hi" may occur at start-up. To silence the alarm, press and release the upper button. Alarm clears once temperature is within factory parameters. For details, see "III.D. Alarm Safeties."

NOTICE

- The control module is fragile, handle very carefully.
- Do not change wiring and connections. Never misconnect terminals.
- Do not short out power supply to test for voltage.

1. Display Icons

Control Module Icons	
Icon	Meaning
	Compressor Compressor running.
	Defrost Appliance is in defrost cycle. See "II.B. Service Diagnosis" for details.
	Evaporator Fan Motor Evaporator fan motor is running. Evaporator fan motor de-energizes when door is open.
	Alarm Appliance is in alarm. See "III.D. Alarm Safeties" for details.

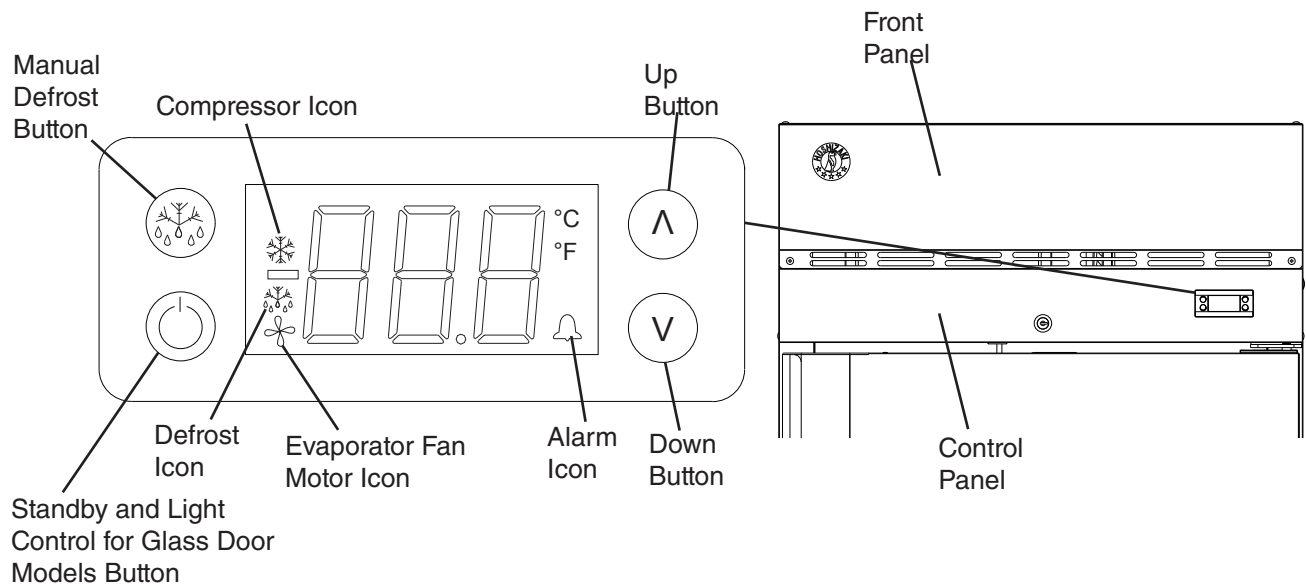

2. Display Layout

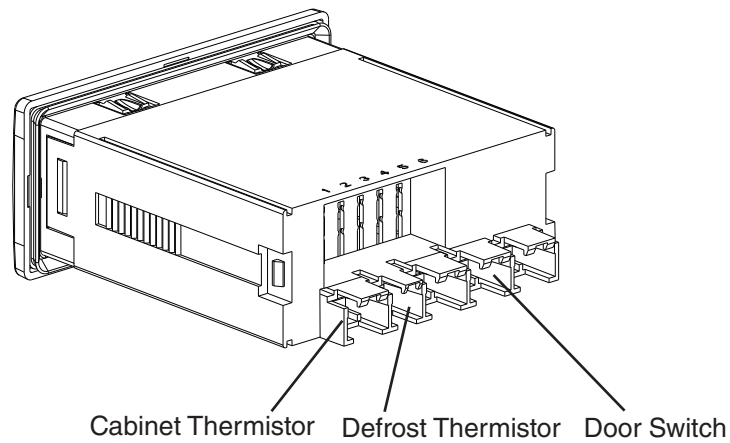

3. Control Module Connections

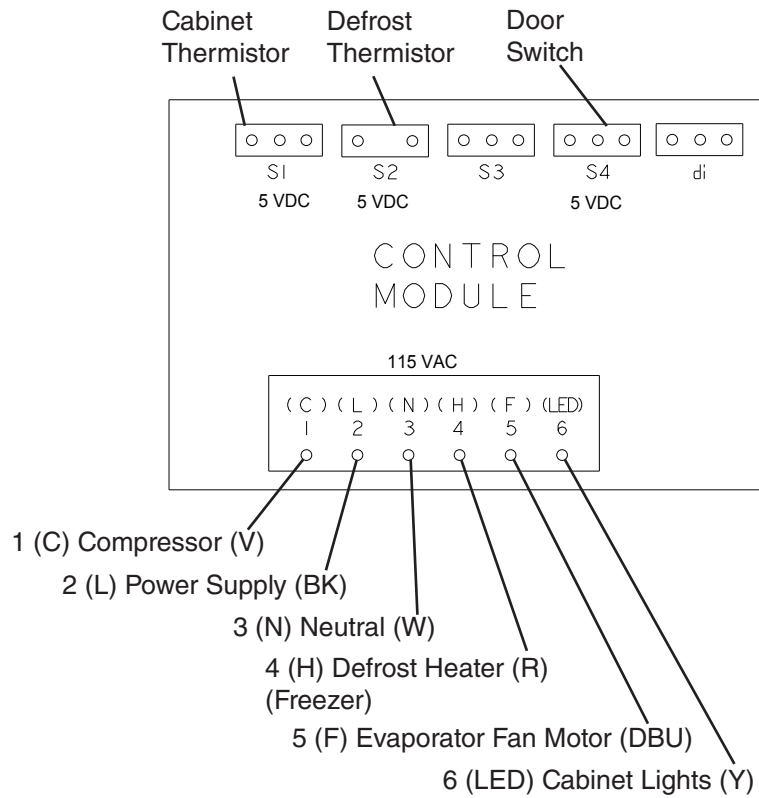

B. Temperature

The temperature default scale is °F, but it can be changed to read °C. To change, see "III.B.3. Changing the Temperature Display Scale (°F or °C)" below.

1. Default Settings

a) Temperature Setpoint:

Model	Auxiliary Code	Temperature Setpoint
Refrigerator	All	38°F (3°C)
Freezer	All	-2°F (-19°C)

b) Temperature Display Scale: °F.

2. Temperature Setpoint

The temperature setpoint is the value for the average cabinet temperature. The temperature differential for the compressor to turn on and off is $\pm 3^{\circ}\text{F}$ ($\pm 1.7^{\circ}\text{C}$) of the temperature setpoint. For example, for a refrigerator temperature setpoint of 36°F (2°C), the compressor comes on at 39°F (3.7°C), and the compressor goes off at 33°F (0.3°C). If necessary, adjust the temperature setpoint as follows:

- 1) To change the temperature setpoint, press and release the up or down button. The current temperature setpoint appears.
- 2) Press the up or down button until the desired value is displayed. After a few seconds, the display returns to the current cabinet temperature and the temperature setpoint is saved. **NOTICE! Do not adjust the temperature setpoint more than 2°F (1°C) at a time. Allow the temperature to stabilize for a minimum of 8 hours before making further temperature setpoint adjustments.**
 - For refrigerators, the temperature setpoint is adjustable between 31°F and 52°F (-0.5°C and 11°C). The factory default is 38°F (3°C).
 - For freezers, the temperature setpoint is adjustable between -10°F and $+12^{\circ}\text{F}$ (-24°C and -11°C). The factory default is -2°F (-19°C).

3. Changing the Temperature Display Scale (°F or °C)

To change the temperature display scale, press and hold either the up or down button for 5 seconds. The factory default is °F.

C. Defrost

To initiate a manual defrost, press the manual defrost button briefly. The defrost icon and "dEF" appear on the display.

1. Refrigerators

Refrigerators use a time-initiated, off-cycle defrost. Defrost occurs when either the 2-hr. cumulative compressor run timer terminates or the 2-hr. continuous compressor run timer terminates. When either the 2-hr. cumulative compressor run timer or the 2-hr. continuous compressor run timer terminates, defrost begins. The 5-min. minimum defrost timer and the 1-hr. maximum defrost timer starts. If energized the compressor de-energizes and the evaporator fan motor continues. Cabinet temperature is not displayed during defrost; "dEF" is displayed in its place along with defrost icon. After the 5-min. minimum defrost timer terminates and the defrost thermistor warms to 44°F (6.6°C), defrost terminates. The defrost icon turns off and the compressor energizes. "dEF" is displayed during defrost and continues for 15 min. after defrost termination. Once the 15-min. "dEF" display timer terminates, cabinet temperature returns to the display. Note: If the defrost thermistor is above 50°F (10°C) the evaporator fan motor de-energizes until the defrost thermistor reaches 49°F (9°C).

2. Freezers

Freezers use a time-initiated, heated defrost. Defrost occurs when either the 5-hr. cumulative compressor run timer terminates or the 4-hr continuous compressor run timer terminates. When either the 5 hr. cumulative compressor run timer or the 4-hr continuous run timer terminates, defrost begins. The 5-min. minimum defrost timer and the 1-hr. maximum defrost timer starts. Cabinet temperature is not displayed during defrost; "dEF" is displayed in its place along with the defrost icon. After the 5-min. minimum defrost timer terminates and the defrost thermistor warms to 77°F (25°C), defrost terminates (defrost heater de-energizes). A 3-min. compressor delay timer starts. Once the 3-min. compressor delay timer terminates, the compressor energizes and a 4-min. evaporator fan motor delay timer (drip time) starts. Once the 4-min. evaporator fan motor delay timer (drip time) terminates, the evaporator fan motor energizes, the defrost icon turns off, and the 15-min. temperature display delay timer starts. Once the 15-min. temperature display delay timer terminates, cabinet temperature is displayed. Note that the 4-min. evaporator fan motor delay time is a maximum; if the defrost thermistor cools to 15°F (-9.5°C) before the 4-min. evaporator fan motor delay timer terminates, the evaporator fan motor will energize. Freezers have a minimum defrost interval of 5 hours.

3. Manual Defrost

To initiate a manual defrost, press the manual defrost button.

D. Alarm Safeties

Alarm signals are designed to protect the appliance and food product. These alarms give information or warnings in the event the appliance is operating out of acceptable parameters. Should one of the alarms occur, follow the instructions in the table below to address the alarm. The alarm code and alarm icon flash with audible alarm. To silence the alarm, press and release the upper button.

Alarm Signals		
Alarm Code	Problem	Corrective Action/Reset Details
dor	Door Switch Alarm: Door has remained open for more than 2 minutes. Door Switch has failed	If obvious corrections such as closing doors does not correct the alarm, call a qualified service technician. Beeps for 10 seconds, then silent for 50 seconds. To silence the alarm, press and release the up button.
E01	Cabinet Thermistor Malfunction Alarm Cabinet thermistor has failed.	Call a qualified service technician. Beeps for 10 seconds, then silent for 50 seconds. To silence the alarm, press and release the up button. Appliance cycles 5 min. on, 5 min. off.
E02	Defrost Thermistor Malfunction Alarm Defrost thermistor has failed.	Call a qualified service technician. Beeps for 10 seconds, then silent for 50 seconds. To silence the alarm, press and release the up button. Appliance cycles on and off with cabinet thermistor.
Hi	High Temperature Alarm Refrigerator: Cabinet temperature has remained above 57°F (13.9°C) for more than 2 hours. Freezer: Cabinet temperature has remained above 26°F (-3.3°C) for more than 2 hours.	If obvious corrections such as closing doors and cleaning the air filter and/or condenser do not bring temperature back in range, call a qualified service technician. Beeps for 10 seconds, then silent for 50 seconds. To silence the alarm and clear "Hi" from the display, press and release the up button. The alarm icon stays on. Automatically resets when temperature returns to normal.
Lo	Low Temperature Alarm Refrigerator: Cabinet temperature has remained below 26°F (-3.3°C) for more than 2 hours. Freezer: Cabinet temperature has remained below -23°F (-30.6°C) for more than 2 hours.	If obvious corrections do not bring the temperature back in range, call a qualified service technician. Beeps for 10 seconds, then silent for 50 seconds. To silence the alarm and clear "Lo" from the display, press and release the up button. The alarm icon stays on. Automatically resets when temperature returns to normal.

E. Safety Devices and Light Control

1. Compressor External or Internal Protector

If combined temperature/amperage value is above the limit specified by the compressor manufacturer, the compressor overload operates independently to turn off the compressor. The compressor overload de-energizes the compressor until the temperature/amperage value returns to an acceptable level.

2. Short-Cycle Protection

There is a 2-min. minimum off-time and on-time for the compressor.

Note: Time may vary with compressor protector or high-pressure switch activation.

3. High-Pressure Switch

If pressure on the high-side of the appliance exceeds Hoshizaki specifications, the high-pressure switch activates and interrupts the compressor circuit, de-energizing the compressor until the pressure returns to an acceptable level.

If the condenser fan motor is operating and the compressor is off, it is most likely that the compressor protector opened. If both the compressor and condenser fan motor are off, it is most likely the appliance is off or the high-pressure switch has opened.

4. Light Control for Glass Door Models

Glass door models feature lights that are controlled by the standby/light control button located on the control module. Press and release the standby/light button to turn the light on or off.

F. Mullion/Perimeter Heater

Refrigerators are equipped with mullion heaters and the freezers are equipped with mullion and perimeter heaters. The heaters are energized (except PT2A and R_2A models) when the appliance is plugged into the electrical outlet. Mullion heater energizes with compressor and condenser fan motor on PT2A and R_2A models.

IV. Refrigeration Circuit and Component Service Information

DANGER

Risk of Fire or Explosion Flammable Refrigerant Used

- Follow handling instructions carefully in compliance with U.S. government regulations.
- Do not use mechanical devices to defrost.
- Do not puncture refrigerant tubing. Risk of fire or explosion due to puncture of refrigerant tubing; follow handling instructions carefully.
- Component parts shall be replaced with like components.
- Servicing shall be done by factory authorized service personnel to minimize the risk of possible ignition due to incorrect parts or improper service.
- Consult instruction manual/service manual before attempting to install or service this product.
- Dispose of properly in accordance with federal or local regulations.
- Do not place any potential ignition sources in or near the appliance.

Risque De Feu Ou D'Explosion Le Frigorigène Est Inflammable

- Suivre attentivement les instructions de manipulation conformément à la réglementation gouvernementale.
- Ne pas utiliser d'appareils mécaniques pour dégivrer le réfrigérateur.
- Ne pas perforer la tubulure contenant le frigorigène. Risque de feu ou d'explosion si la tubulure contenant le frigorigène est perforée; suivre les instructions de manutention avec soin.
- Les pièces des composants doivent être remplacées par des pièces et accessoires équivalents.
- L'entretien doit être effectué par le personnel de service autorisé par le fabricant afin de minimiser les risques d'inflammation attribuables à l'installation d'une pièce inadéquate ou à la mauvaise exécution du service.
- Consulter le manuel du propriétaire/guide de réparation avant de tenter une réparation. Toutes les mesures de sécurité doivent être respectées.
- Éliminer conformément aux règlements fédéraux ou locaux.
- Ne placez aucune source d'inflammation potentielle dans ou près de l'appareil.

⚠ WARNING

- Wear appropriate personal protective equipment (PPE) when servicing the appliance.
- Technician must utilize a combustible gas leak detector at all times.
- Notify everyone in the immediate area that you are working with flammable refrigerant.
- Do not work on appliance in a confined space. Confirm area is well ventilated.
- Identify and eliminate all possible ignition points in a 10 ft. (3 m) area around service area.
- Do not use mechanical devices to defrost.
- Use non-sparking tools.
- Class B dry chemical fire extinguisher or equivalent must be available.
- Do not pressurize system above 200 PSIG during leak check procedure or prior to evacuating refrigeration system.
- This appliance should be diagnosed and repaired only by qualified service personnel to reduce the risk of death, electric shock, serious injury, or fire.
- To reduce the risk of electric shock, do not touch the plug with damp hands.
- Unplug the appliance from the electrical outlet before servicing.
- Make sure all food zones in the appliance are clean after the appliance is serviced.

A. Service for Refrigerant Lines

WARNING

- Repairs requiring the refrigeration circuit to be opened must be performed by properly trained and EPA-certified service personnel.
- Use an electronic leak detector or soap bubbles to check for leaks. Add a trace of refrigerant to the system (if using an electronic leak detector), and then raise the pressure using nitrogen gas (140 PSIG). Do not use R-290 as a mixture with pressurized air for leak testing.

NOTICE

- Always recover the refrigerant and store it in an approved container. Do not discharge the refrigerant into the atmosphere.
- Do not leave the system open for longer than 15 minutes when replacing or servicing parts. The Polyol Ester (POE) oils used in R-290 appliances can absorb moisture quickly. Therefore it is important to prevent moisture from entering the system when replacing or servicing parts.
- Always install a new drier every time the sealed refrigeration system is opened. Do not replace the drier until after all other repair or replacement has been made. Install the new drier with the arrow on the drier in the direction of the refrigerant flow.
- When brazing, protect the drier by using a wet cloth to prevent the drier from overheating. Do not allow the drier to exceed 250°F (121°C).

Refrigerant leaks must be repaired as soon as they are discovered. If not, refrigerant charge should be recovered from the system until the leak can be repaired.

When repairing a leak:

- Repair the leak properly – Remove the refrigerant, examine the leak source, determine the reason for the leak, and carry out the proper course of action.
- Before repairing the leak, ensure that the refrigerant has been recovered and the system purged with nitrogen when brazing.
- Be sure to remove piercing valves attached to the system after repairs are made.

1. Refrigerant Recovery

Using proper refrigerant practices, place piercing valves toward the end (crimped area) of the high and low-side process tubes, then recover the refrigerant into an approved container or device.

2. Brazing

⚠ DANGER

Risk of Fire or Explosion Flammable Refrigerant Used

- Servicing shall be done by factory authorized service personnel to minimize the risk of possible ignition due to incorrect parts or improper service.

Risque De Feu Ou D'Explosion Le Frigorigène Est Inflammable

- L'entretien doit être effectué par le personnel de service autorisé par le fabricant afin de minimiser les risques d'inflammation attribuables à l'installation d'une pièce inadéquate ou à la mauvaise exécution du service.

⚠ WARNING

- Wear appropriate personal protective equipment (PPE) when servicing the appliance.
- You must have a combustible gas leak detector in the immediate work area at all times.
- You must have a Class B chemical fire extinguisher available at all times.
- Notify all persons in the immediate area that you are working with a flammable refrigerant.
- Do not use silver alloy or copper alloy containing arsenic.
- Be sure the area is clear of refrigerant vapor before brazing.

- 1) Purge with nitrogen for 2 min. **WARNING! Purging with nitrogen gas assures all refrigerant has been removed from the refrigeration circuit.**
- 2) Braze/repair/replace damaged component or fittings while purging with nitrogen gas flowing at a pressure of 3 to 5 PSIG.

NOTICE

- Always install a new drier every time the sealed refrigeration system is opened.
- Do not replace the drier until after all other repair or replacement has been made. Install the new drier with the arrow on the drier in the direction of the refrigerant flow.
- When brazing, protect the drier by using a wet cloth to prevent the drier from overheating. Do not allow the drier to exceed 250°F (121°C).

- 3) Use soap bubbles to check for leaks. Raise the pressure using nitrogen gas (190 PSIG). Do not use any refrigerant as a mixture with pressurized air for leak testing.
- 4) Once leak checking is complete, release the nitrogen gas from the system.

3. Evacuation

- 1) Attach a vacuum pump to the system. Be sure to connect the charging hoses to both high and low-side refrigerant piercing valves.

<i>IMPORTANT</i>

The vacuum level and vacuum pump may be the same as those for current refrigerants. However, the rubber hose and gauge manifold to be used for evacuation and refrigerant charge should be exclusively for POE oils.
--

- 2) Turn on the vacuum pump, then open the gauge manifold valves. Never allow the oil in the vacuum pump to flow backwards.
- 3) Allow the vacuum pump to pull down to a 29.9" Hg vacuum (500 microns). Evacuating period depends on pump capacity.
- 4) Close the low-side valve and high-side valve on the gauge manifold.
- 5) Disconnect the gauge manifold hose from the vacuum pump and attach it to a refrigerant service cylinder. Remember to loosen the connection and purge the air from the hose. For the required refrigerant charge, see the nameplate. Hoshizaki recommends only virgin or reclaimed refrigerant which meets ARI Standard 700 (latest edition) be used.

4. Recharge

- 6) R-290 can be charged in either the liquid or vapor state. A liquid charge is preferred. Service kit SP-5459 is recommended when recharging an R-290 refrigeration circuit. Connect the refrigerant hose to the service cylinder and bleed air out of refrigerant hose. Next, invert the service cylinder and place it on the scales. Zero out the scales. Open the high-side valve on the gauge manifold.
- 7) Allow the system to charge with liquid until the proper charge weight is met.
- 8) Close the high-side valve on the gauge manifold. If charging is complete, skip to step 10.
- 9) If necessary, add any remaining charge to the system through the low-side.
NOTICE! To prevent compressor damage, use a throttling valve or liquid dispensing device to add the remaining liquid charge through the low-side refrigerant access valve with the compressor running. Close the refrigerant cylinder valve and let the low-side refrigerant equalize to the system, then close the low-side manifold gauge. Unplug the appliance from the electrical outlet.
- 10) Remove the refrigerant hose from the service cylinder. Pinch off (crimp down) the process tubes just below the piercing valves.
- 11) Remove the piercing valves. Cut the process tubes to remove the piercing valve holes then braze the process tubes closed. Note: Be sure there is no refrigerant leak or refrigerant in the area before brazing.
- 12) Use a combustible gas leak detector or soap bubbles to check for leaks again.
- 13) Place red sleeves over the process tubes.
- 14) Plug the appliance back into the electrical outlet. Allow the appliance to cool to setpoint before reloading.

B. Component Service Information

⚠ DANGER

- Component parts shall be replaced with like components.
- Les pièces des composants doivent être remplacées par des pièces et accessoires équivalents.

NOTICE

When replacing a component listed below, see the notes to help ensure proper operation.

Component	Notes
Compressor	Install a new start relay and compressor external protector. WARNING! To reduce the risk of electric shock, be sure to reconnect the compressor's ground wire.
Thermostatic Expansion Valve	<ul style="list-style-type: none"> • Attach the thermostatic expansion valve bulb to the suction line in the same location as the previous bulb. • The bulb should be between the 10 and 2 o'clock positions on the tube. • Secure the bulb with the clamp and holder.
Defrost Thermistor	After working with or around the defrost thermistor on a freezer, make sure the defrost thermistor wire is not touching the defrost heater.

C. Door Reversal

The appliance is provided with a cabinet design which, after being delivered to the installation location, permits changing of the door swing from left to right or right to left. To change the door swing, See Instruction Manual "I.F. Door Reversal".

NOTICE! Improper installation may result in the doors not closing completely and/or the gaskets not sealing correctly. For further details, contact your local Hoshizaki distributor or Hoshizaki Technical Support at 1-800-233-1940.

V. Maintenance

⚠ WARNING

- Unplug the appliance before performing maintenance to prevent electric shock or injury by moving parts. To reduce the risk of electric shock, do not touch the plug with damp hands.
- Before performing maintenance, move all foods into another clean refrigerator or freezer.

1. Air Filter

Check the air filter at least twice a month. When clogged, use warm water and a neutral cleaner to wash the filter.

2. Condenser

Inspect the condenser air filter bi-weekly. Wash with warm water and neutral cleaner if dirty. Check the condenser once a year and use a brush or vacuum cleaner to clean the condenser as required.

3. Condensate Wick (Except DT1A-HS and Freezer on DT2A-FS)

The condensate wick must be cleaned at least once a year. More frequent cleaning may be required in some conditions to maintain proper flow. Follow the steps below.

- 1) Unplug the appliance from the electrical outlet. **WARNING!** To reduce the risk of electric shock, do not touch the plug with damp hands.
- 2) Remove the wick from the retainers.
- 3) Clean or replace the wick. **NOTICE!** If the wick is clogged/deteriorating replace.
- 4) Replace the wick in its correct position.

NOTICE! Be sure the wick is positioned into the condensate pan.

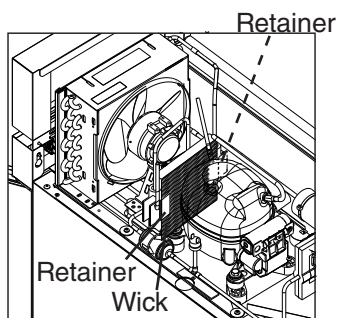
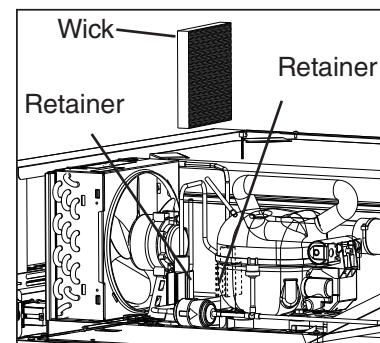

Fig. 1



- 5) Plug the appliance back in.

4. Power Supply Connection

If the plug or power cord is damaged, contact your local Hoshizaki service representative or local Hoshizaki distributor immediately and ask for repairs.

All other maintenance or service on this appliance should be performed in accordance with the Hoshizaki Instruction Manual by a qualified service technician.

VI. Preparing the Appliance for Periods of Non-Use

⚠ WARNING

Prevent the doors from closing to reduce the risk of children getting trapped.
--

<i>NOTICE</i>

Clean the cabinet interior, door gaskets, and shelves.
--

- 1) Before shutting down the appliance, move the stored food into another refrigerator or freezer.
- 2) Unplug the appliance. **WARNING! To reduce the risk of electric shock, do not touch the plug with damp hands.**

VII. Disposal

DANGER

Risk of Fire or Explosion Flammable Refrigerant Used

- Follow handling instructions carefully in compliance with U.S. government regulations.
- Do not puncture refrigerant tubing. Risk of fire or explosion due to puncture of refrigerant tubing; follow handling instructions carefully.
- Dispose of properly in accordance with federal or local regulations.

Risque De Feu Ou D'Explosion Le Frigorigène Est Inflammable

- Suivre attentivement les instructions de manipulation conformément à la réglementation gouvernementale.
- Ne pas perforer la tubulure contenant le frigorigène. Risque de feu ou d'explosion si la tubulure contenant le frigorigène est perforée; suivre les instructions de manutention avec soin.
- Éliminer conformément aux règlements fédéraux ou locaux.

WARNING

When preparing the appliance for disposal, remove the doors/drawers to reduce the risk of children getting trapped. Leave any shelves in place so that children may not easily climb inside.

The appliance contains refrigerant and must be disposed of in accordance with applicable national, state, and local codes and regulations. Refrigerant must be recovered by properly certified service personnel.

VIII. Technical Information

A. Electrical and Refrigerant Data

Model	AC Supply Voltage	Amperes	Refrigerant (oz.)	Design Pressure (PSIG)		
			R290	HIGH	LOW	
R1A-FG/FGCL/FGCR//HG R1A-FS/FSJ/FSL/FSLJ/HS/HSL PT1A-FG-FG/FS-FS/HS-HS	115/60/1	5	4.6	360	190	
R2A-FG/HG/FS/HS		8	4.9			
PT2A-FS-FS/HS-HS/FG-FG			5.3			
R3A-FS/HS		9.5	4.6 Right 4.6 Left			
RN1A-FS RT1A-FS-FS		6.4	4.6			
RN2A-FS RT2A-FS-FS		8.2	5.1			
F1A-FG/FS/FSL/HG/HS/HSL		9	4.1			
F2A-FG/HG/FS/HS		9.5	4.2			
F3A-FS/HS		208-230/115/60/1	11			4.1 Right 4.1 Left
DT1A-HS		115/60/1	5.5			Freezer 2.5
		Refrigerator 2.1				
DT2A-FS/HS	115/60/1	14	Freezer 4.1			
			Refrigerator 4.6			

See the nameplate for electrical and refrigerant data. The nameplate is located inside the cabinet. We reserve the right to make changes in specifications and design without prior notice.

B. Wiring Diagrams

1. R1A/R2A/F1A-FG/FGCL/FGCR/FS/FSJ/FSL/FSLJ/HG/HS/HSL, PT1A-FG-FG/FS-FS/HS-HS

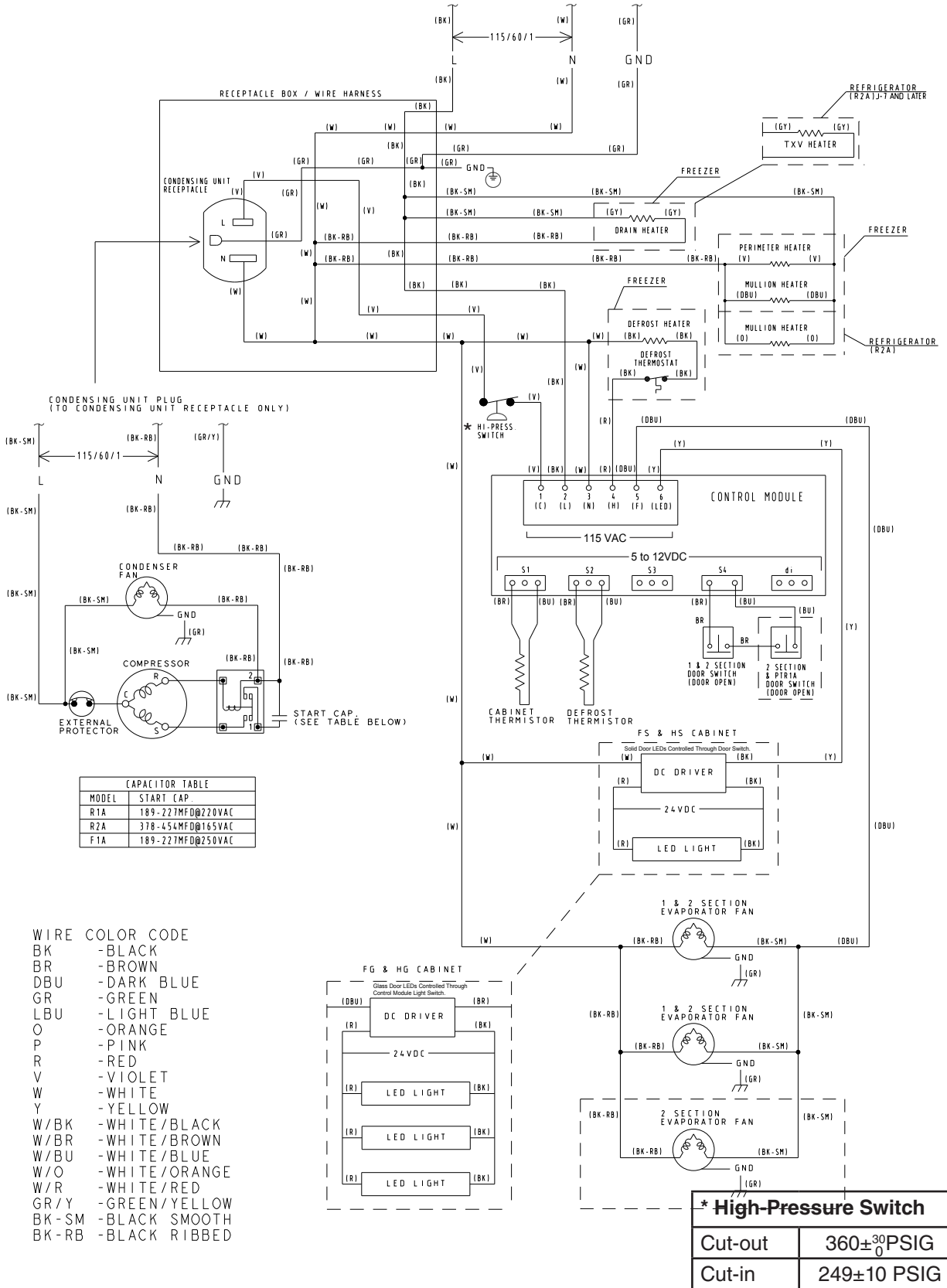

2. RN1A-FS, RT1A-FS-FS

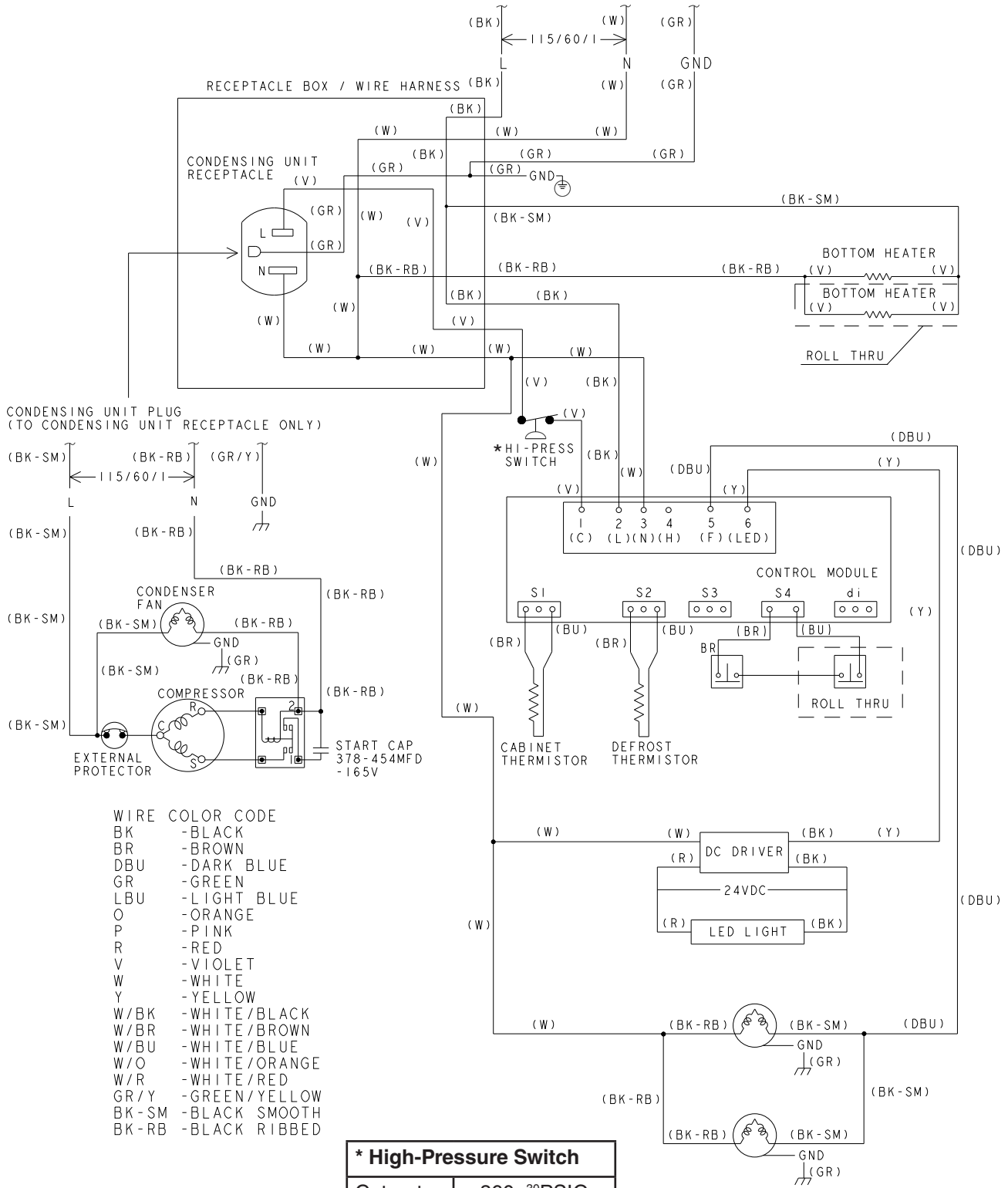

3. RN2A-FS, RT2A-FS-FS

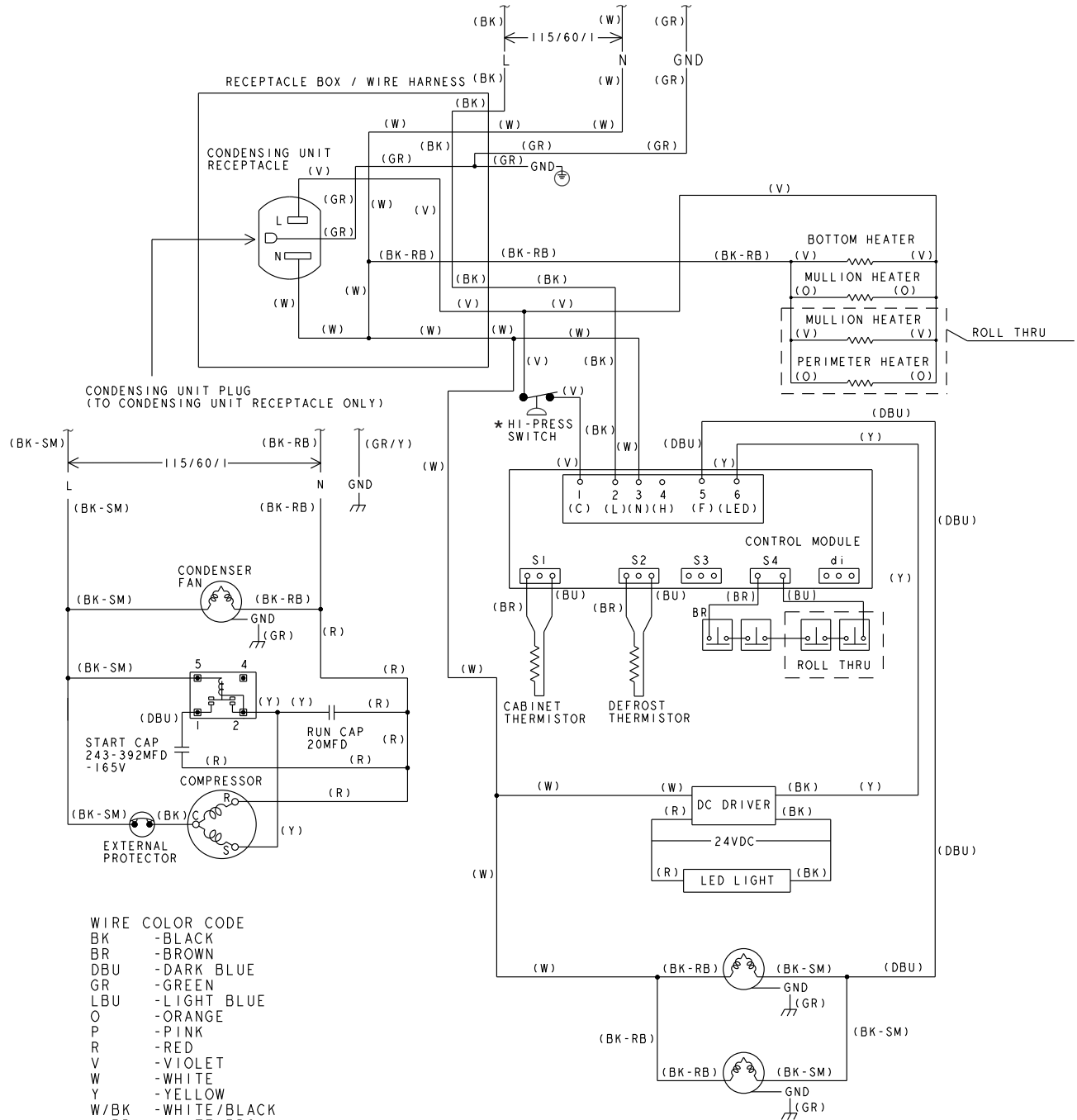

* High-Pressure Switch	
Cut-out	360± ³⁰ ₀ PSIG
Cut-in	249±10 PSIG

4. PT2A-FG-FG/FS-FS/HS-HS

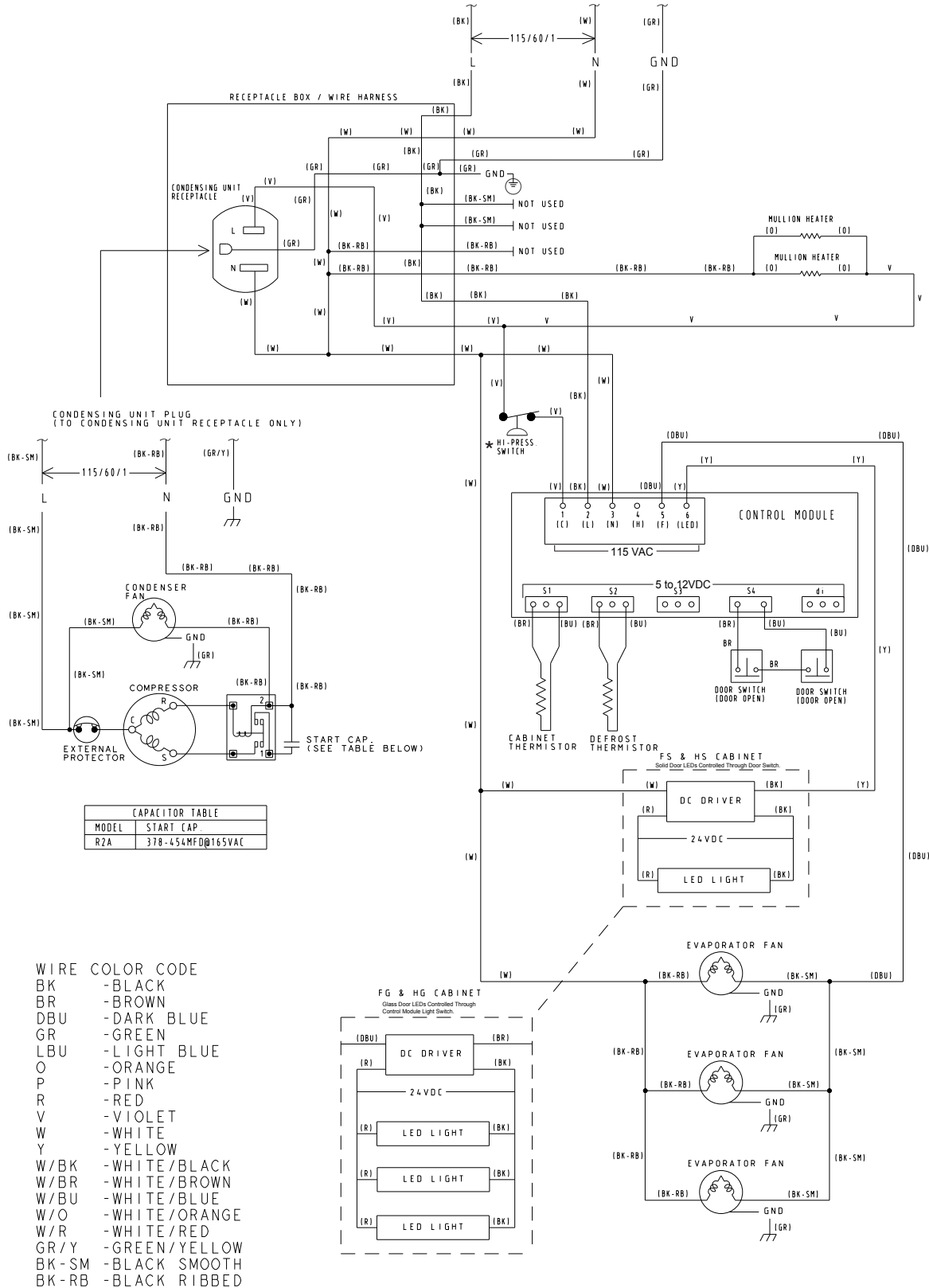

5. R3A-FG/FGCL/FGCR/FS/FSCL/FSCR/HS/HG

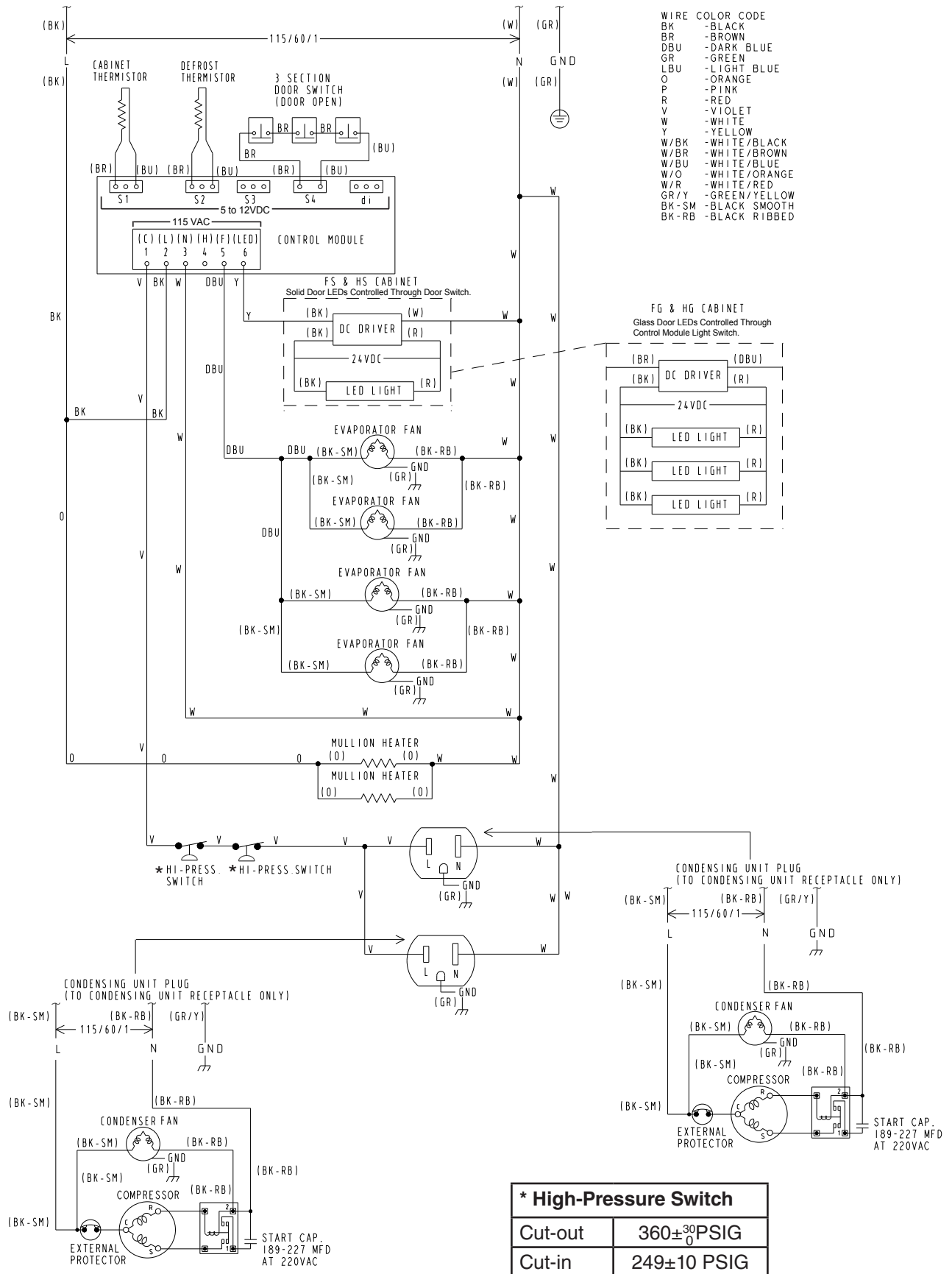

6. F2A-FG/FS/HG/HS

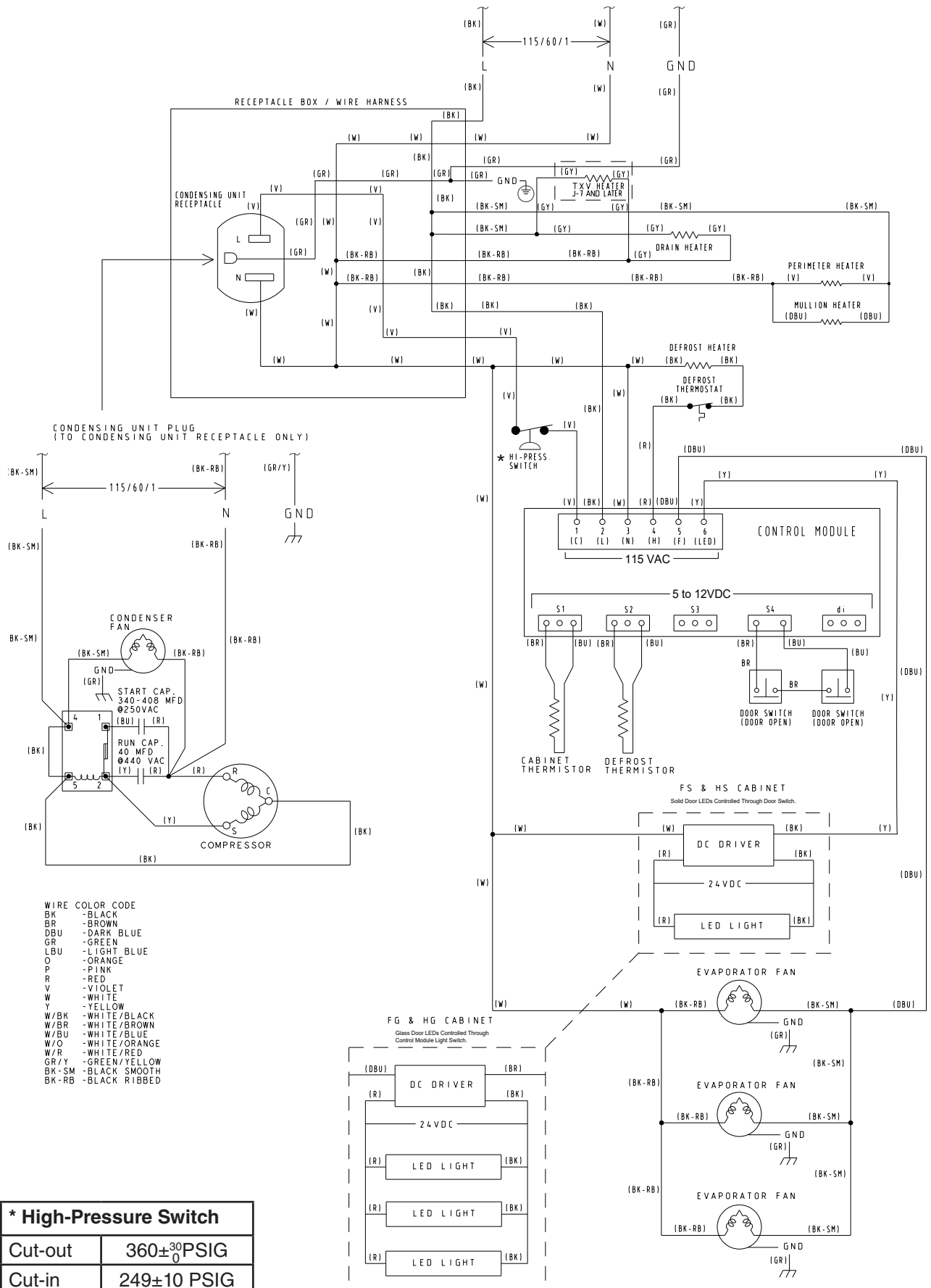

7. F3A-FS/HS

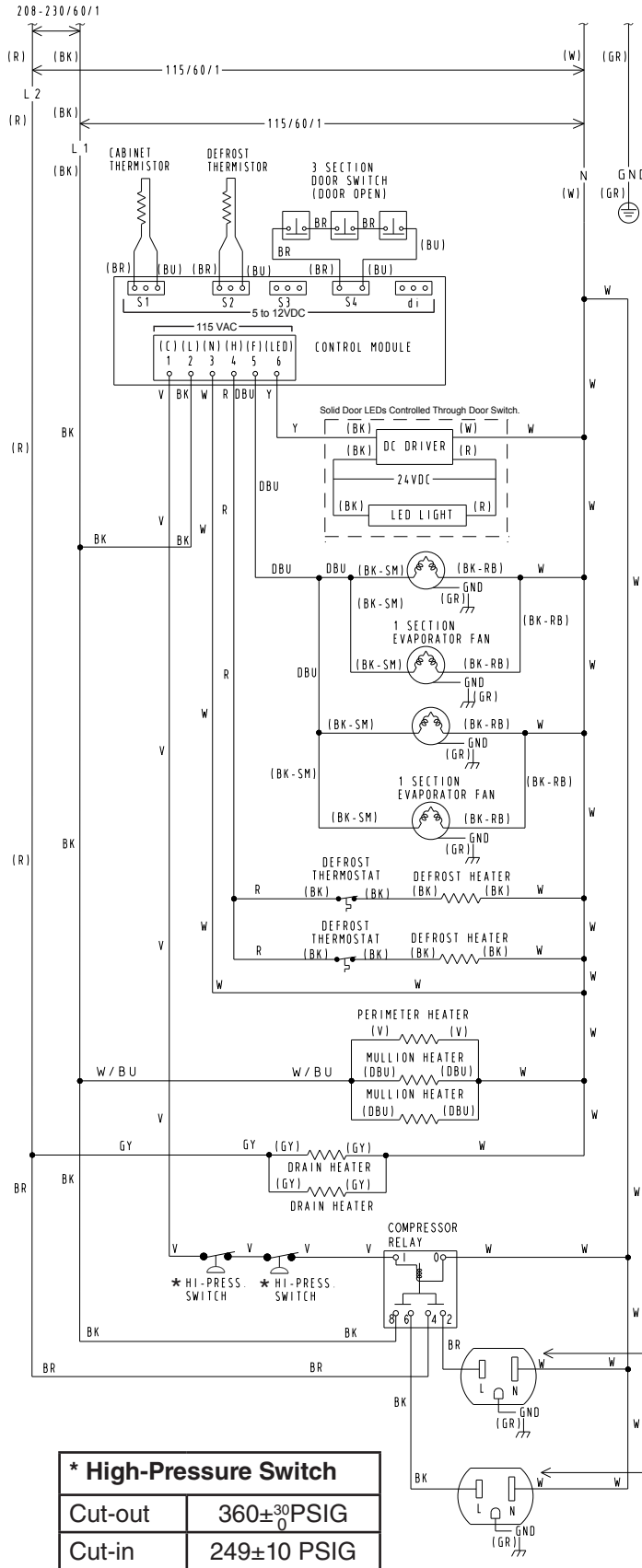

- WIRE COLOR CODE**
- BK - BLACK
 - BR - BROWN
 - DBU - DARK BLUE
 - GR - GREEN
 - LBU - LIGHT BLUE
 - O - ORANGE
 - P - PINK
 - R - RED
 - V - VIOLET
 - W - WHITE
 - Y - YELLOW
 - W/BK - WHITE/BLACK
 - W/BR - WHITE/BROWN
 - W/BU - WHITE/BLUE
 - W/O - WHITE/ORANGE
 - W/R - WHITE/RED
 - GR/Y - GREEN/YELLOW
 - BK-SM - BLACK SMOOTH
 - BK-RB - BLACK RIBBED

*** High-Pressure Switch**

Cut-out	360±30 PSIG
Cut-in	249±10 PSIG

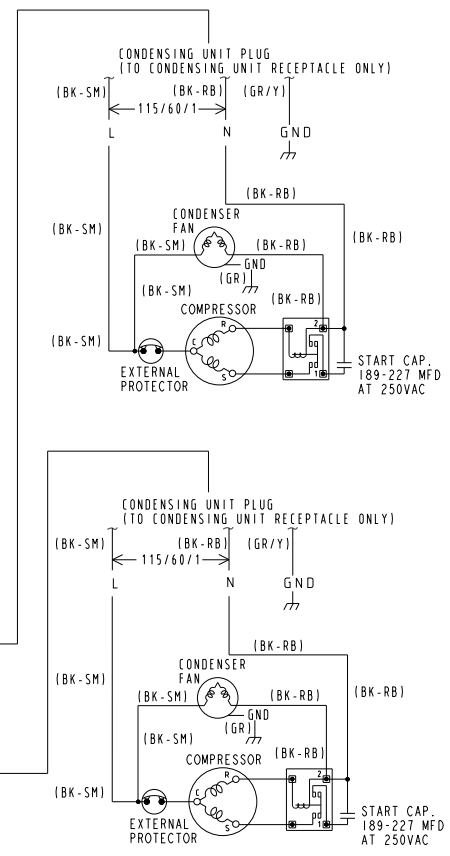

8. DT1A-HS

- WIRES COLOR CODE
- BK - BLACK
 - BR - BROWN
 - DBU - DARK BLUE
 - GR - GREEN
 - LBU - LIGHT BLUE
 - OR - ORANGE
 - P - PINK
 - R - RED
 - V - VIOLET
 - W - WHITE
 - Y - YELLOW
 - W/BK - WHITE/BLACK
 - W/BR - WHITE/BROWN
 - W/BU - WHITE/BLUE
 - W/O - WHITE/ORANGE
 - W/R - WHITE/RED
 - GR/Y - GREEN/YELLOW
 - BK-SM - BLACK SMOOTH
 - BK-RB - BLACK RIBBED

CTB = COMPRESSOR COVER TERMINAL BLOCK	
L1	NOT USED
L2	LINE
N	NEUTRAL
	GROUND

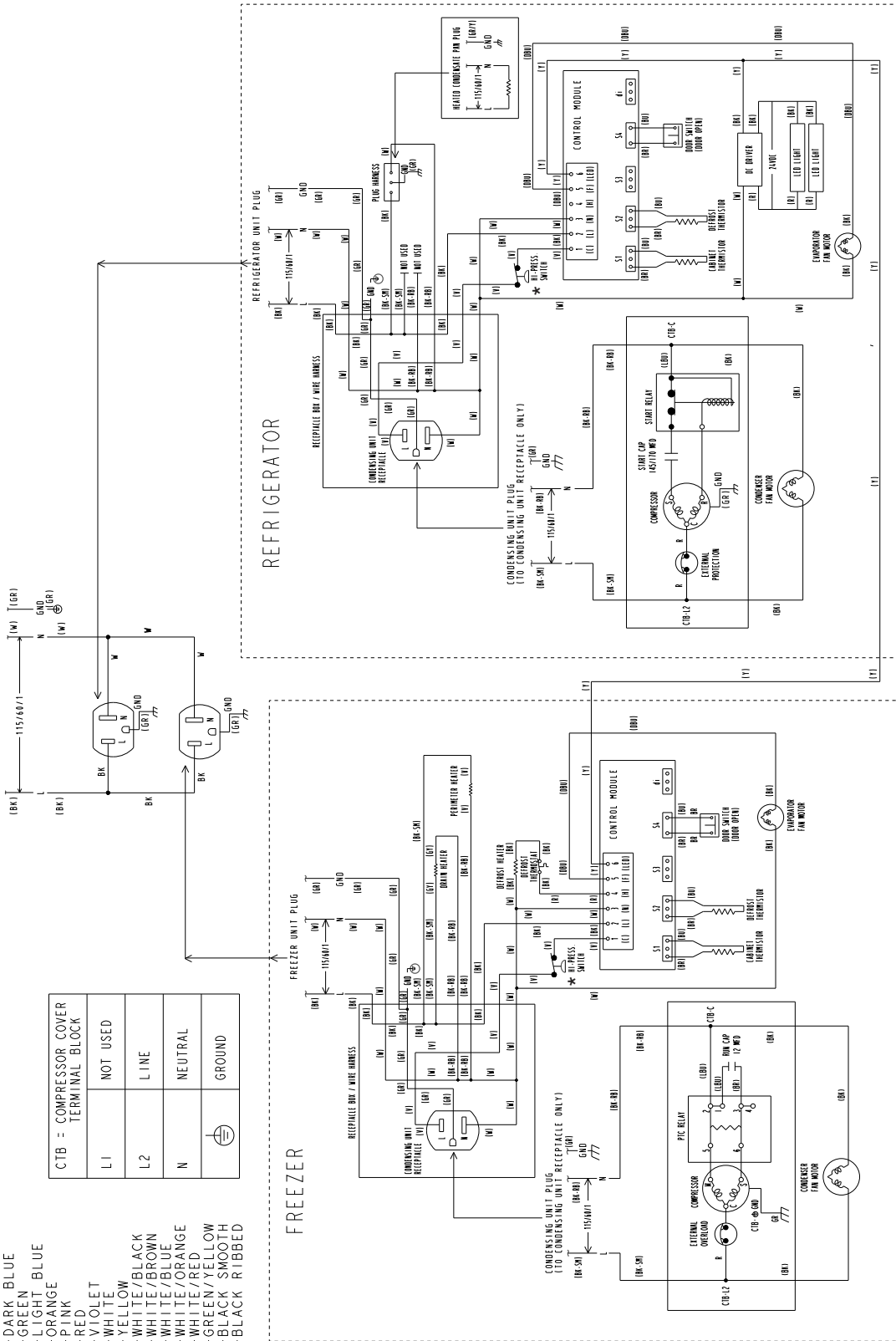

* High-Pressure Switch		
Cut-out	360± ³⁰ ₀ PSIG	
Cut-in	249±10 PSIG	

9. DT2A-FS/HS

Main Connection

WIRE COLOR CODE	
BK	BLACK
GR	GREEN
W	WHITE

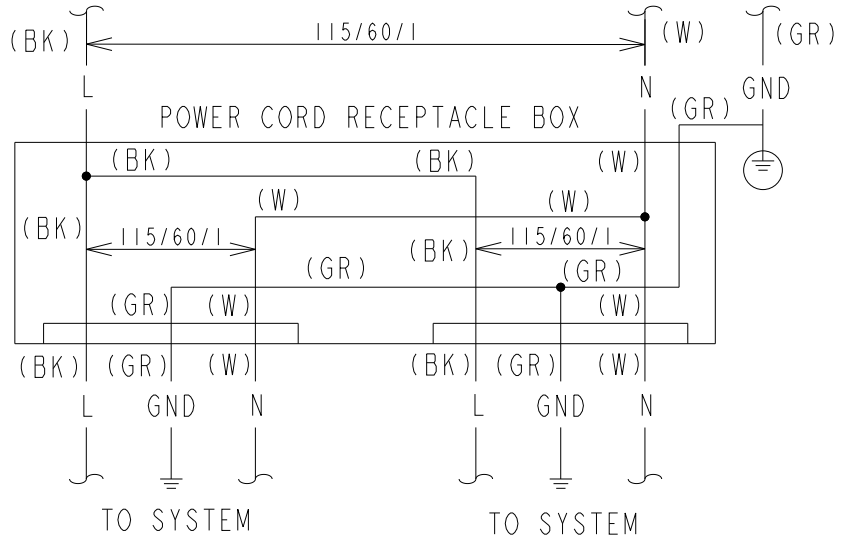
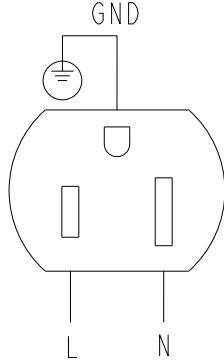

System Connection

