

ASSEMBLY INSTRUCTION FOR ACME FURNITURE

MODEL#LV04273

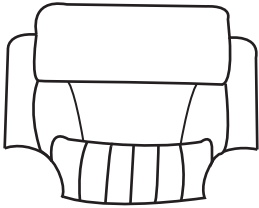
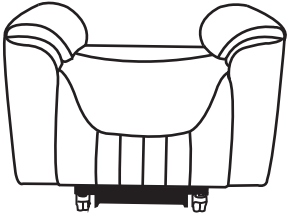

Thank you for purchasing the quality product. Be sure to check all packing material carefully for small parts which may have come loose inside the carton during shipment. Separate, Identify and count all parts and metal hardware. Compare with all parts listed to be sure all parts are present. If any part(s) are missing or damaged, please contact your local furniture dealer. For efficient and speedy service, please indicate the model number and code letter of part(s) needed.

COMPONENT PARTS

DESCRIPTION	PART NAME	Q'TY(PCS)
①:Chair Seat		1 PC
②:Chair Back		1 PC

Note: This chair will come with 2 separate boxes, we ship them on the same day but the carrier may deliver them to your door on different days, please kindly wait for more 1-3 business days. if you only receive one box. Please make sure you get 1 x BACK Box and 1 x SEAT Box before assembly.

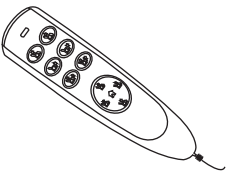
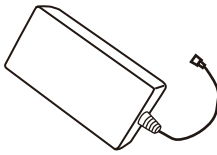
HARDWARE REQUIRED

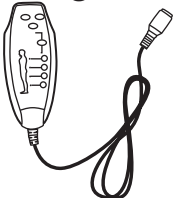
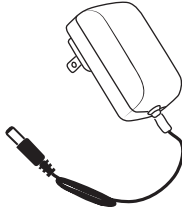
A:Motor Remote 	B:Transformer 	C:Plug 
D:Massage Remote 	E:Power Cord 	

Attention

***Some number parts listed on the instruction sheet may not be in parts bag as they may be assembled. Carefully check parts and packing materials prior to ordering replacements. ***

HOW TO ASSEMBLE:

STEP 1

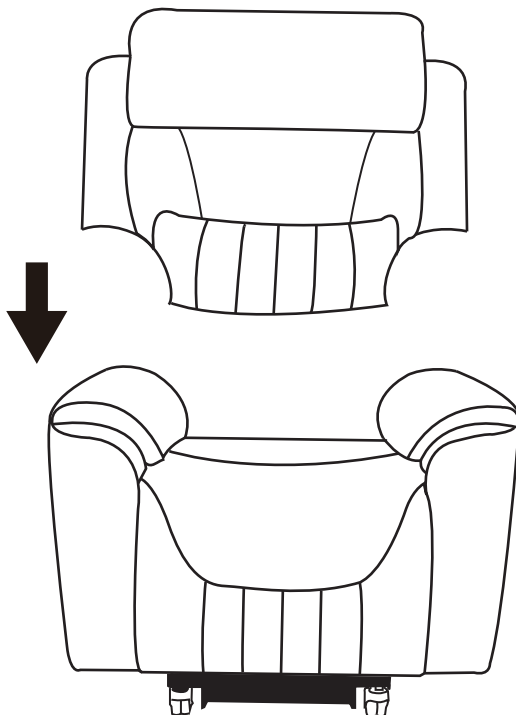
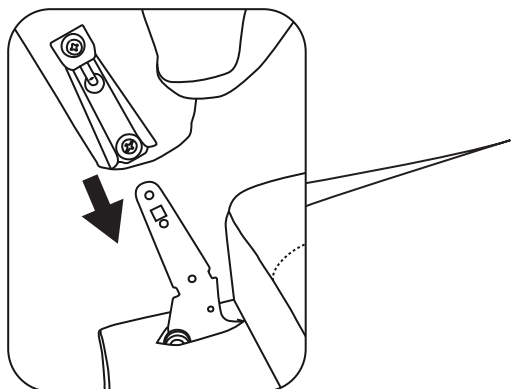

Insert the Chair back (②) on the Chair seat (①). Gently push down until the back locks into position.

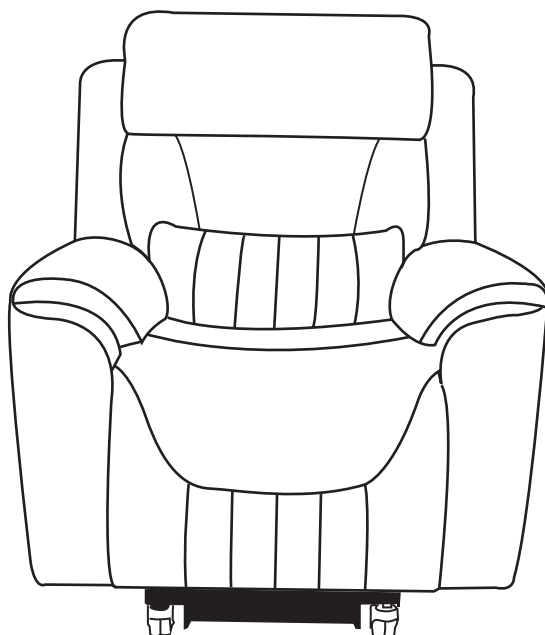

HOW TO CONNECT THE MOTOR WIRES:

STEP 2

- No.1: Wire connect the motor and the Motor Remote(A),
- No.2: Wire connect the motor and transformer (B).
- No.3: Plug(C) connect the transformer (B)

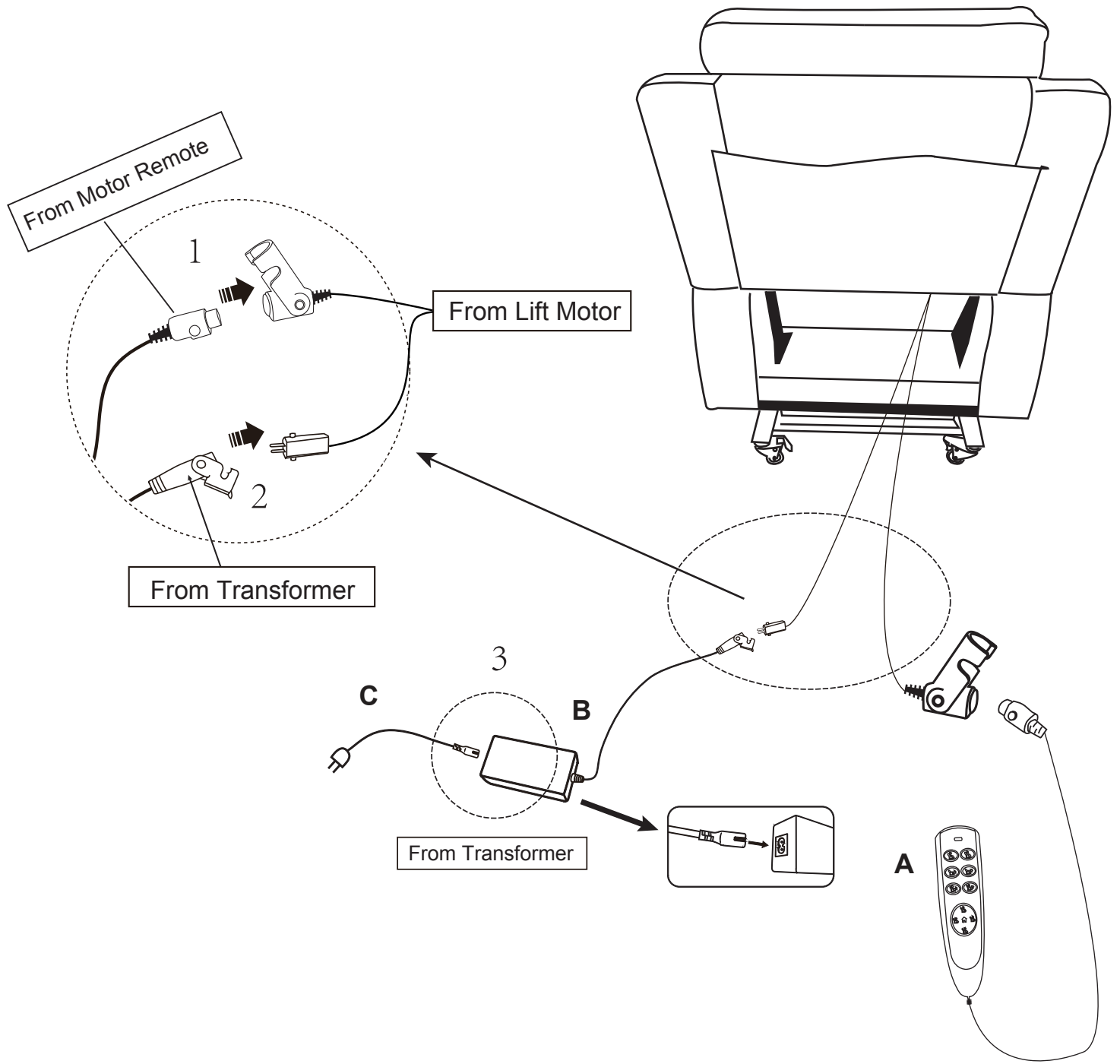

HOW TO CONNECT THE MOTOR WIRES:

STEP 3

No.4: Back motor: Blue label wire connect the blue label wire.

No.5: Tilt motor: Green label wire connect the green label wire.

No.6: Seat motor: White label wire connect the white label wire.

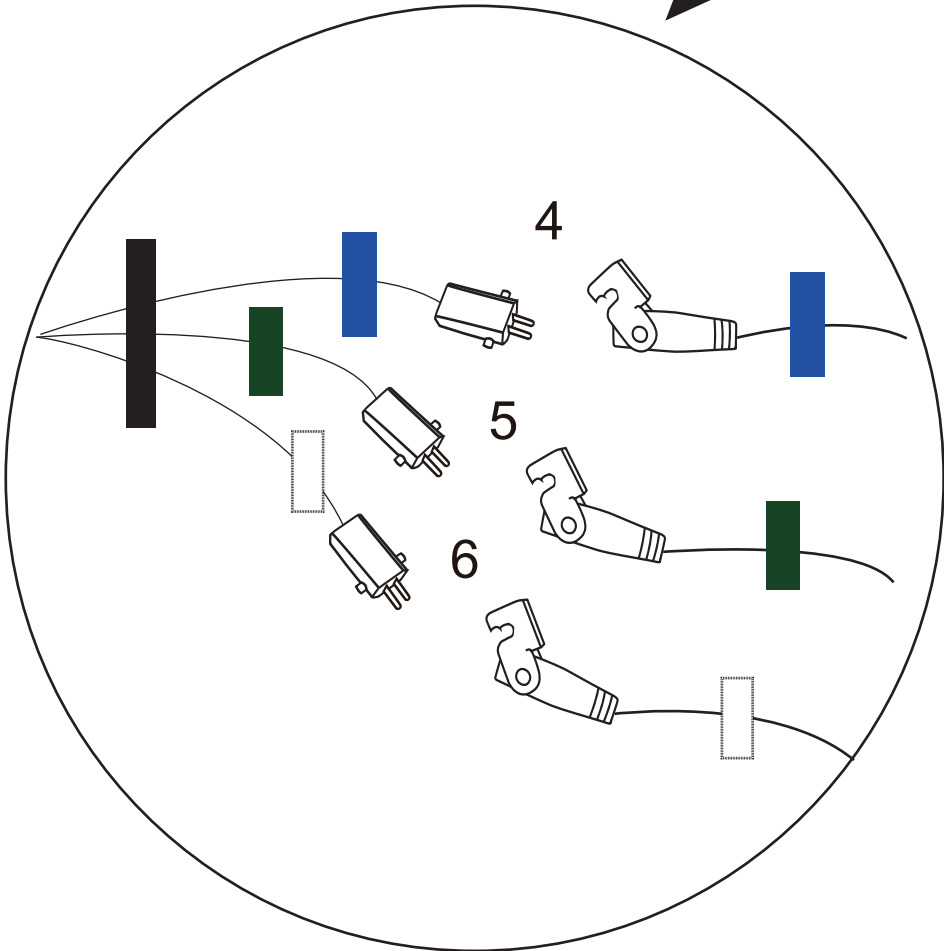
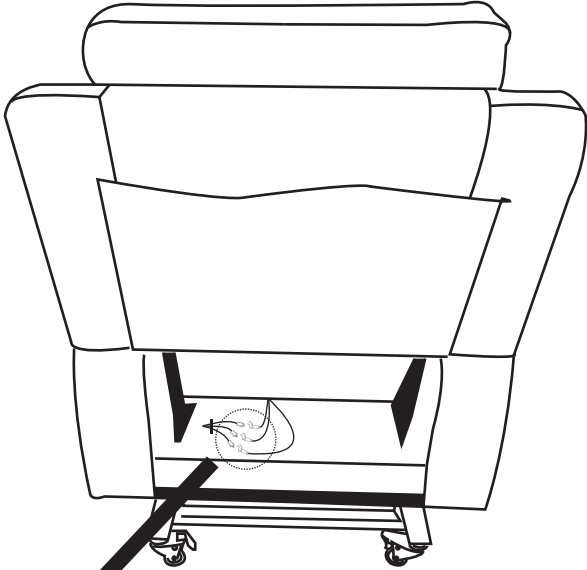

HOW TO CONNECT THE MOTOR WIRES:

STEP 4

There are 4 wires coming out of the backrest, if you find that the wire is missing, check to make sure it's not stuck between the backrest and the Seat before you make the connection.

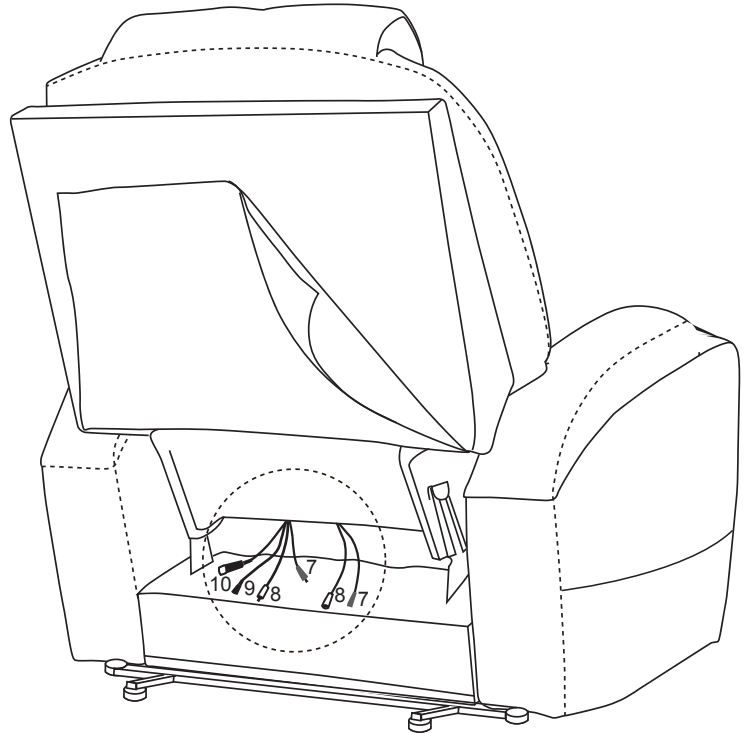

Chair back (②)

Chair seat (①)

Wire 1: RED wire from the backrest connect to the RED wire from the seat.

Wire 2: WHITE wire from the backrest connect to the WHITE wire from the seat.

Wire 3: BLACK smaller wire from the backrest connect to the POWER CORD(E).

Wire 4: BLACK bigger wire from the backrest connect to the Massage Remote(D).

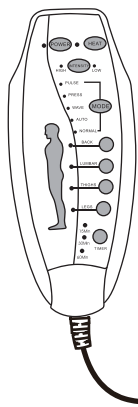

Massage Remote(D)



Power Cord(E)

HOW TO USE MOTOR REMOTE:

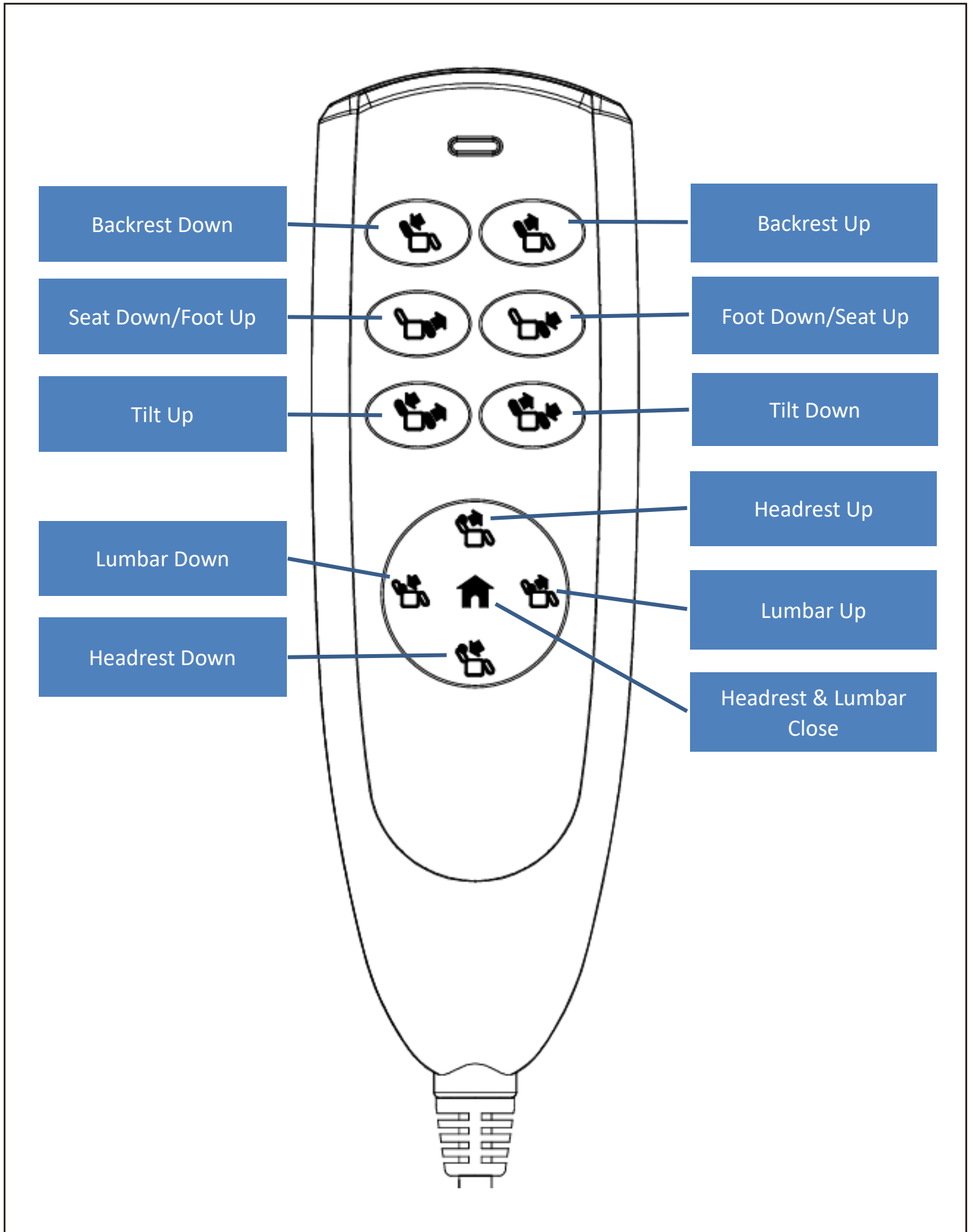

HOW TO USE MASSAGE REMOTE:

