

Model #

2403h

McKenzie Lateral File Cabinet

GAC = Glazed Antique Cherry finish

JAV = Java finish

PEC = Pecan finish

Assembly Instructions

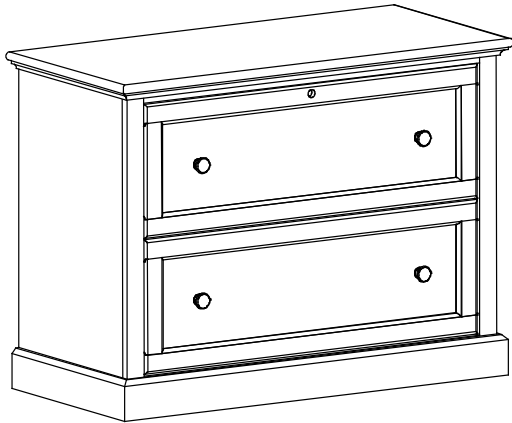

Thank you for allowing us to help you furnish your home. We are certain you will be delighted with your new furniture for many years to come.

IMPORTANT NOTES:

- For normal household use only. *Not* recommended for commercial use.
- Use a protective pad when you use the top of this piece as a writing surface.
- Do not climb, sit or stand on this piece of furniture.
- Do not overload the drawers.
- Place heaviest items in the bottom drawer.
- Unload items before you move this unit.
- This assembly requires two people.

⚠ WARNING		
	<p>Children have died from furniture tipover. To reduce the risk of furniture tipover:</p> <ul style="list-style-type: none"> • ALWAYS install Anti-tip device provided. • NEVER put a TV on this product. • NEVER allow children to stand, climb or hang on any drawers, doors or shelves. • NEVER open more than one drawer at a time. • DO NOT defeat or remove the drawer interlock system; it is an important stability and safety system. • Place heaviest items in the lowest drawers. 	<p>DO NOT remove the interlock system except for maintenance as shown. NEVER use the unit without the interlock installed following the instructions.</p>
	<ul style="list-style-type: none"> • NEVER allow children to stand, climb or hang on any drawers, doors or shelves. • NEVER open more than one drawer at a time. • DO NOT defeat or remove the drawer interlock system; it is an important stability and safety system. • Place heaviest items in the lowest drawers. 	<p>The snapper arm must be angled forward in the locked positions to engage the interlock system after removing a drawer. See diagram below.</p> <div style="text-align: right;"> <p>Close up view of locked snapper</p> </div>
<p>Drilling, sawing, sanding or machining wood products can expose you to wood dust, a substance known to the state of California to cause cancer. Avoid inhaling wood dust or use a dust mask or other safeguards for personal protection.</p> <p>For more information go to: www.p65warnings.ca.gov/wood</p> <p>This product can expose you to chemicals, including formaldehyde, which are known to the State of California to cause cancer.</p> <p>For more information go to: www.p65warnings.ca.gov/furniture</p>		

DESIGN SUBJECT TO CHANGE WITHOUT NOTICE.

CUSTOMER SERVICE

If you ever have questions about your furniture, please do not hesitate to contact us. In the unlikely event you need a replacement part; we can make those parts available through an authorized Whittier Wood Furniture dealer. If you cannot order replacement parts through your dealer, please contact our customer service department.

Hours: Our friendly customer service staff can be reached:

Monday-Friday 8:00 a.m. to 5:00 p.m. (Pacific Time).

You may leave a message 24 hours a day, seven days a week.

Customer Service: 800-653-3336 • Outside the U.S.: 541-687-0213

Fax: 541-687-2060 • Email: info@whittierwood.com



P.O. Box 2827
Eugene, OR 97402 USA

Production Code :











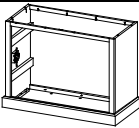









VN

11/23

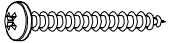

2403h McKenzie Lateral File Cabinet

Parts List

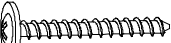
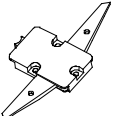
Please identify the parts and check that quantities received match those on this list.
If you need to replace a part, refer to the following letter and part name.

Part	Description		Quantity
Ag	Case Assembly		1
B	Top Assembly (attached)		1
C	Back (attached)		1
D	Drawer (inserted)		2
E	Upper Drawer Face (installed)		1
F	Lower Drawer Face (installed)		1
G	Drawer Divider (attached)		4
H	Lock (attached)		1
I	#6 x 5/8" Philtruss Screw (inserted)		16
J	H. D. 16" Drawer Slides (pre-installed sets)		2
K	#6 x 3/4" Philtruss Screw (inserted)		23
L	#6 x 1/2" Philtruss Screw (inserted)		22
M	Knob (attached)		4
Nf	#8 x 1-1/2" Machine Screw Tuscan (installed)		4
O	Plastic File Rail (attached)		8
Pf	#8 x 7/8" Black Lo-Profile Screw (inserted)		16
Q	#8 x 1-1/4" Pan Head Screw (inserted)		11
S	#8 x 1-5/8" Black Screw (inserted)		8
U	#8 x 2-3/4" Black Screw		3
X	Tack Glide (inserted)		2
Y	1/4" Insert Nut (inserted)		2
ZF	#8 x 1-3/8" Lo-Profile Screw (inserted)		6
ZG	Anti-Tip Snapper (attached)		1

2403h McKenzie Lateral File Cabinet
Parts List

Part	Description		Quantity
ZH	Drawer Clip (attached)		2
ZI	Slotted Leveler (installed)		2
ZJ	Leveler Adjustment Key (attached to Owners Manual)		1

2403h McKenzie Lateral File Cabinet

Assembly Instructions

Tools Required: Phillips Screwdriver, Pencil.

Tool Provided: Leveler Adjustment Key in the Zip bag taped to the Owner's Manual and Safety Guide.

1. This piece of furniture includes a drawer interlock system allowing only one drawer to be open at a time. This is a safety feature to reduce the risk of tip over. Do not defeat or remove the drawer interlock system. Drawers need to be removed to reconfigure the file drawers and anchor the file cabinet to reduce the risk of tip over.
2. When removing drawers from furniture featuring the Anti-Tip Drawer Interlock System it is important that the drawer be installed back in its original location. Numbers and letters are stamped on the back of the drawers. Stamping sequence starts at the bottom, moves to the top. Drawer back stamping example:

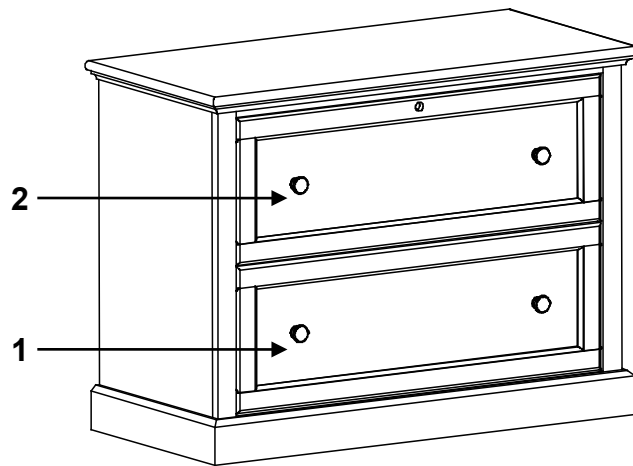

Fig. 2

3. To remove a drawer from the Case (Ag), pull up on the left Drawer Release Lever while pushing down on the right Drawer Release Lever and pull out the drawer. See Figures 3 and 3a. Note where each drawer came from to make sure you place them back into their correct positions.

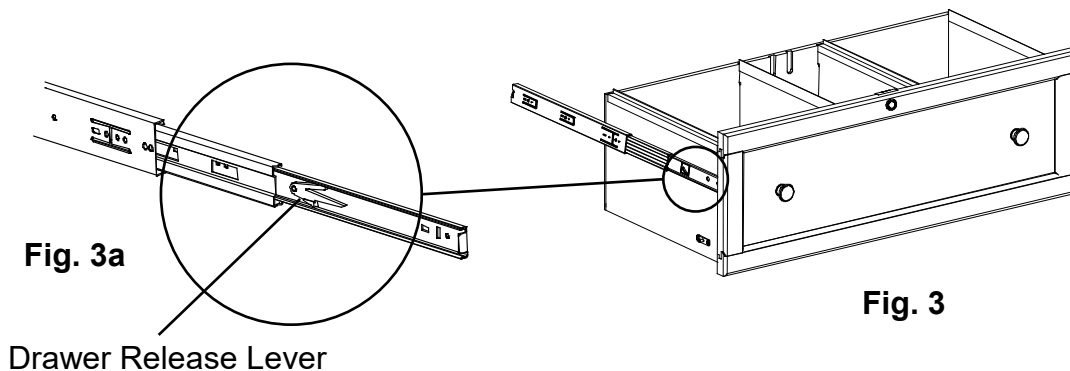

Fig. 3a

Drawer Release Lever

Fig. 3

2403h McKenzie Lateral File Cabinet

Assembly Instructions

4. The drawer interlock system has two major parts; drawer clips attached to the sides of the drawers and anti-tip snapper arms attached to the side panels as shown in Figure 4. If you want to remove more than one of the secured drawers, you have to change the position of the snapper arm to ensure it is unlocked.

When you open a secured drawer, the snapper arm will be angled forward. See Figure 4a. Remove the drawer. Push the snapper arm back so it is straight. See Figure 4b. Now you can remove another drawer adjacent to the one already removed.

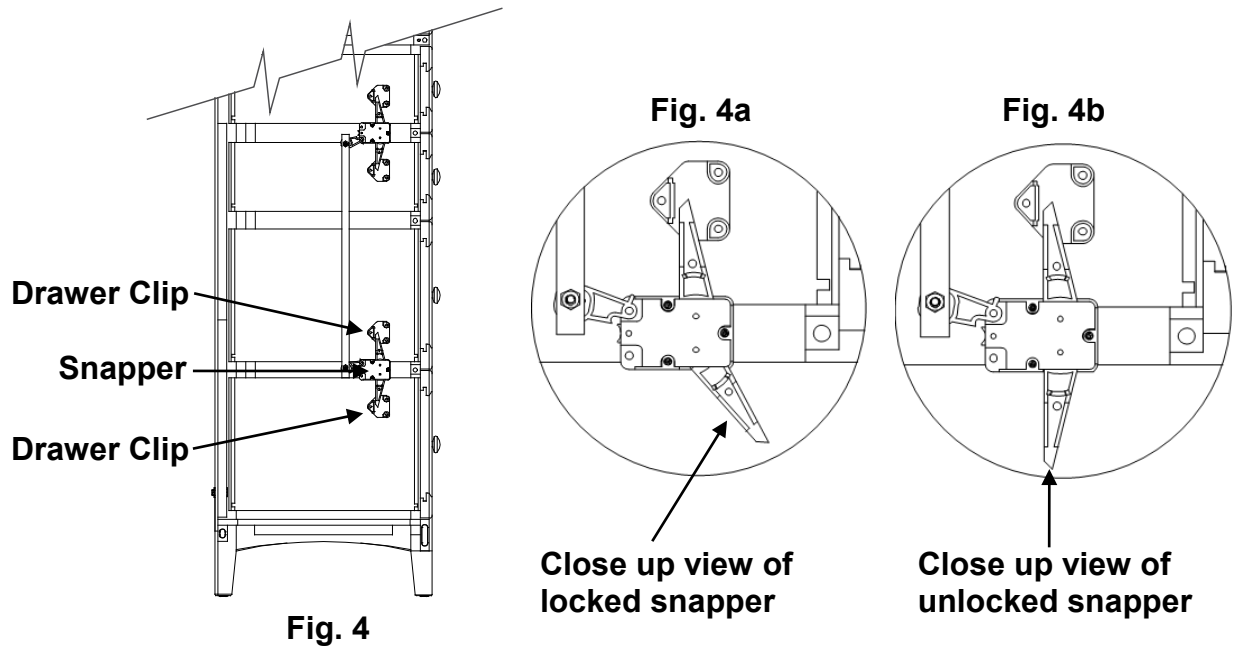

Continued on Page 6

2403h McKenzie Lateral File Cabinet

Assembly Instructions

5. Place the unit at its final destination. Use the Leveler Adjustment Key (ZJ), found in the Zip bag taped to the Owner's Manual and Safety Guide to rotate the Slotted Levelers (ZI) on the bottoms of the legs until the unit is level. See Figures 5 and 5a. Use a protective pad for the top surface.



Fig. 5

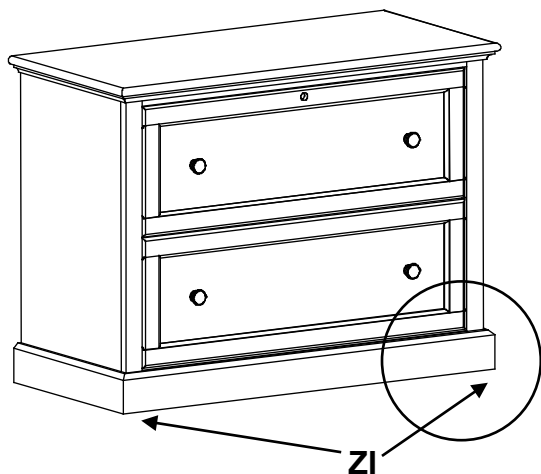
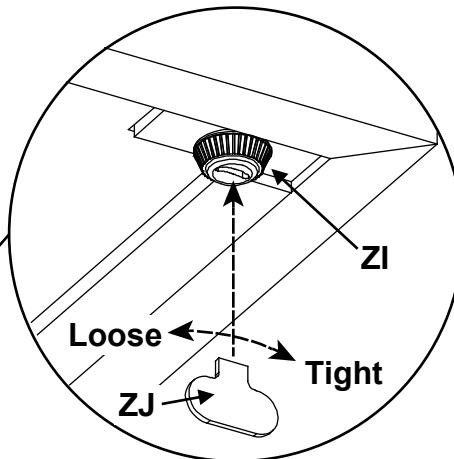

Fig. 5a



There are two ways to help stabilize your file cabinet to reduce the risk of tip-over.

6. **Choice #1**
Remove the drawers from the cabinet. Place the cabinet against the wall. Using three #8 x 2-3/4" Black Screws (U), secure the unit to the wall. See Figure 6.

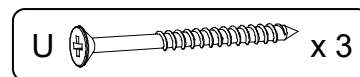
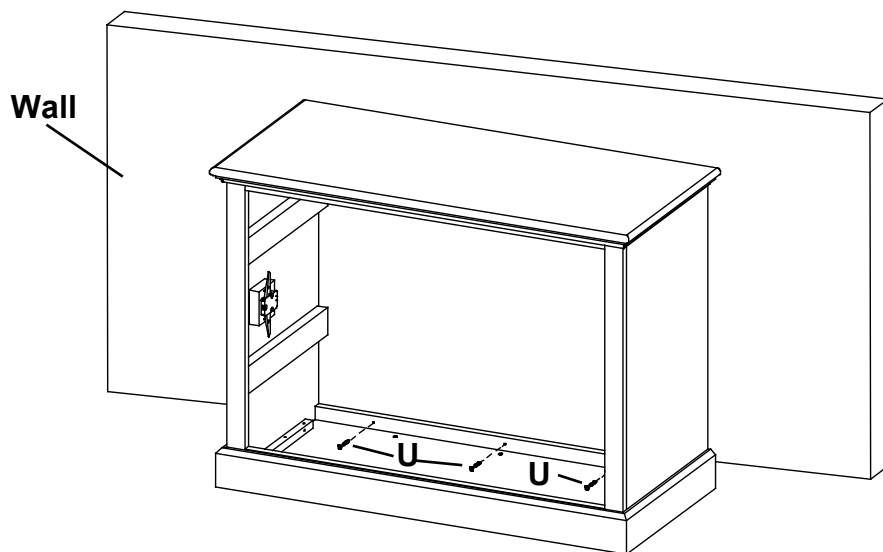

Fig. 6

2403h McKenzie Lateral File Cabinet

Assembly Instructions

7. Choice #2

Using three #8 x 2-3/4" Black Screws (U), secure the file cabinet to the floor. See Figure 7.

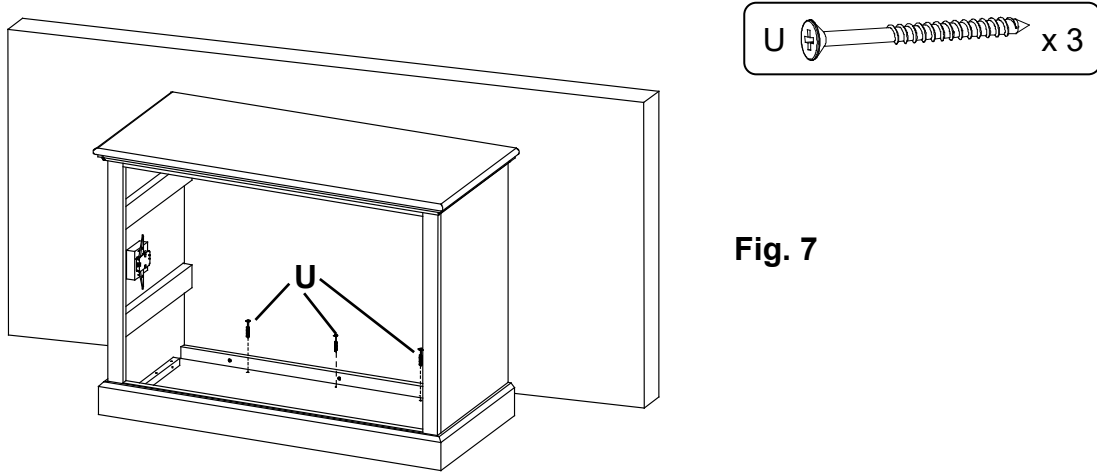

Fig. 7

8. The file drawers arrive configured to accommodate letter/letter sized files. But each drawer has the flexibility to be configured as letter/letter, letter/legal or legal/legal. To set up a section to hold legal files, remove a drawer. Remove one #8 x 1-5/8" Black Screw (S) from the drawer back and one from the bottom. Move the Drawer Divider (G) to the center slot. Attach the Divider in place with two #8 x 1-5/8" Black Screws (S). See Figures 8, 8a and 8b. Repeat for as many sections as you need.

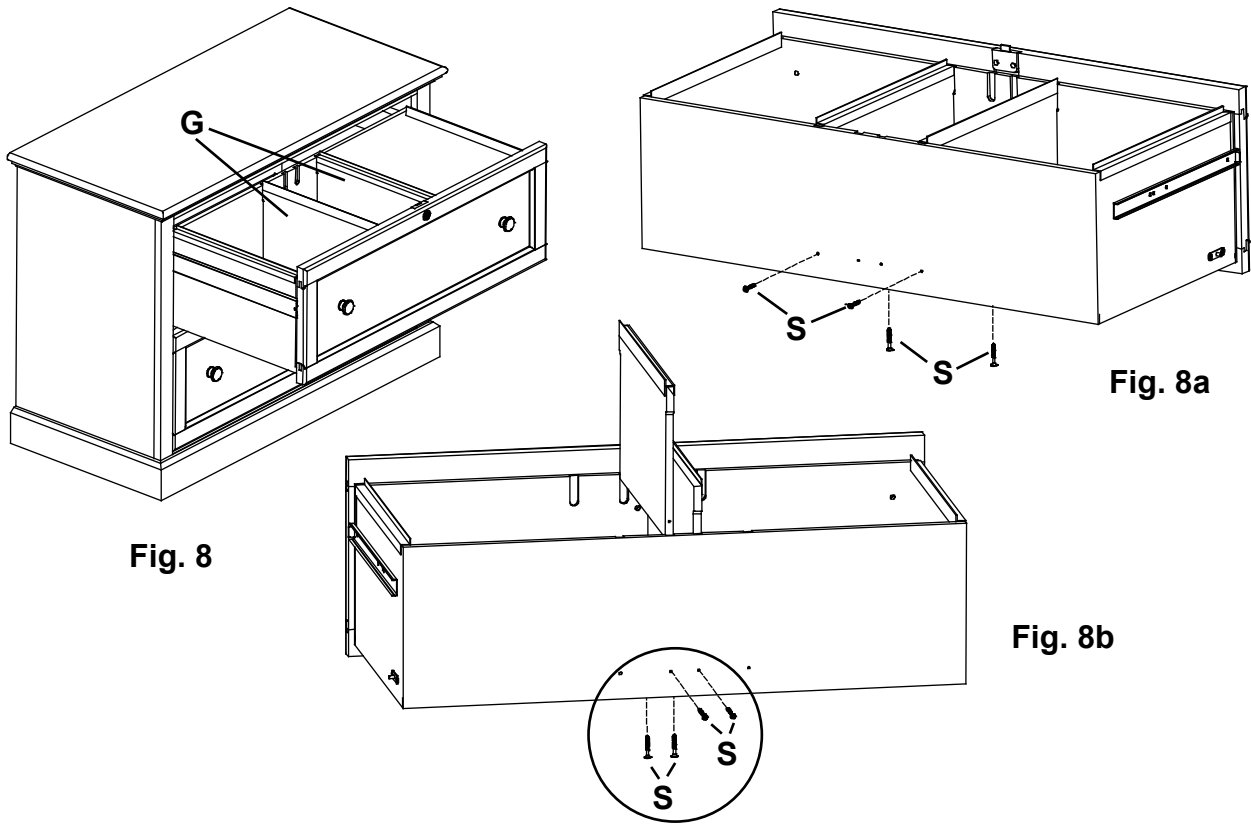

Fig. 8

Fig. 8a

Fig. 8b