



HOSHIZAKI

Service Manual

Modular Cubelet Serenity Series

Models

FS-1001MLJ-C with SRC-10J

FS-1022MLJ-C with SRC-10J

FS-1500MLJ-C with SRC-14J



hoshizakiamerica.com

Number: 73222
Issued: 3-22-2018
Revised: 9-4-2019

⚠ WARNING

Only qualified service technicians should install and service the appliance. To obtain the name and phone number of your local Hoshizaki Certified Service Representative, visit www.hoshizaki.com. No service should be undertaken until the technician has thoroughly read this Service Manual. Failure to service and maintain the appliance in accordance with this manual will adversely affect safety, performance, component life, and warranty coverage and may result in costly water damage. Proper installation is the responsibility of the installer. Product failure or property damage due to improper installation is not covered under warranty.

Hoshizaki provides this manual primarily to assist qualified service technicians in the service of the appliance.

Should the reader have any questions or concerns which have not been satisfactorily addressed, please call, send an e-mail message, or write to the Hoshizaki Technical Support Department for assistance.

Phone: 1-800-233-1940; (770) 487-2331

Fax: 1-800-843-1056; (770) 487-3360

E-mail: techsupport@hoshizaki.com

HOSHIZAKI AMERICA, INC.

618 Highway 74 South

Peachtree City, GA 30269

Attn: Hoshizaki Technical Support Department

Web Site: www.hoshizaki.com

NOTE: To expedite assistance, all correspondence/communication **MUST** include the following information:

- Model Number _____
- Serial Number _____
- Complete and detailed explanation of the problem.

IMPORTANT

This manual should be read carefully before the appliance is serviced. Read the warnings and guidelines contained in this manual carefully as they provide essential information for the continued safe use, service, and maintenance of the appliance. Retain this manual for any further reference that may be necessary.

CONTENTS

Important Safety Information	5
I. Construction and Water/Refrigeration Circuit Diagram	8
A. Construction	8
1. Icemaker	8
2. Condensing Unit	9
3. Icemaking Unit.....	10
B. Water/Refrigeration Circuit Diagram.....	11
II. Sequence of Operation and Service Diagnosis	12
A. Sequence of Operation Flow Chart.....	12
1. Operation Flow Chart.....	12
2. Shutdown Flow Chart.....	13
B. Service Diagnosis	14
C. Control Board Check.....	21
D. Bin Control Check	25
E. Power Switch and Control Switch.....	27
1. Power Switch.....	27
2. Control Switch.....	27
F. Float Switch Check and Cleaning	28
G. Diagnostic Tables.....	30
III. Controls and Adjustments	33
A. Control Board	33
1. Control Board Layout	34
2. LED Lights and Audible Alarm Safeties	35
3. Ice Purge Cycle Bypass.....	35
B. Controls and Adjustments	36
1. Default Dip Switch Settings	36
2. BC (Infrared Sensor) Shutdown Delay (S1 dip switch 1, 2, 3)	37
3. Drain Frequency Control (S1 dip switch 4)	37
4. Continuous Dispensing Timer (S1 dip switch 5 & 6).....	37
5. Bin Control Selector (S1 dip switch 7)	38
6. BC (Mech. Stand-Alone or Backup (only)) Shutdown Delay (S1 dip switch 8)	38
7. Shutdown Sequence (S1 Dip Switch 9)	38
8. Factory Use (S1 Dip Switch 10).....	38
IV. Refrigeration Circuit and Component Service Information.....	39
A. Refrigeration Circuit Service Information	39
B. Component Service Information.....	42
V. Maintenance	51
VI. Disposal.....	53

VII. Technical Information.....	54
A. Specification and Performance Data Sheets.....	54
1. FS-1001MLJ-C with SRC-10J	54
2. FS-1022MLJ-C with SRC-10J.....	55
3. FS-1500MLJ-C with SRC-14J	56
B. Wiring Diagrams.....	57
1. FS-1001MLJ-C and FS-1022MLJ-C	57
2. FS-1500MLJ-C	58
3. SRC-10J Condensing Unit	59
4. SRC-14J Condensing Unit	60

Important Safety Information

Throughout this manual, notices appear to bring your attention to situations which could result in death, serious injury, damage to the appliance, or damage to property.

⚠ WARNING Indicates a hazardous situation which could result in death or serious injury.

NOTICE Indicates a situation which could result in damage to the appliance or property.

IMPORTANT Indicates important information about the use and care of the appliance.

⚠ WARNING

The appliance should be destined only to the use for which it has been expressly conceived. Any other use should be considered improper and therefore dangerous. The manufacturer cannot be held responsible for injury or damage resulting from improper, incorrect, and unreasonable use. Failure to service and maintain the appliance in accordance with this manual will adversely affect safety, performance, component life, and warranty coverage and may result in costly water damage.

To reduce the risk of death, electric shock, serious injury, or fire, follow basic precautions including the following:

- Only qualified service technicians should install and service the appliance.
- The appliance must be installed in accordance with applicable national, state, and local codes and regulations. Failure to meet these code requirements could result in death, electric shock, serious injury, fire, or damage to the appliance.
- The appliance must be installed in accordance with applicable national, state, and local codes and regulations.
- To reduce the risk of electric shock, do not touch the icemaker power switch or plug with damp hands. Make sure the icemaker power switch is in the "OFF" position before plugging in or unplugging the icemaker.
- **Before Servicing: FS:** Move the icemaker's power switch to the "OFF" position. Unplug the icemaker from the electrical outlet. **SRC:** Turn off the power supply to the remote condensing unit. Place the disconnect (if applicable) in the off position. Lockout/Tagout to prevent the power supply from being turned back on inadvertently.
- Do not make any alterations to the icemaker or condensing unit. Alterations could result in electric shock, injury, fire, or damage to the appliance.

⚠ WARNING, continued

FS

- The icemaker requires an independent power supply of proper capacity. See the nameplate for electrical specifications. Failure to use an independent power supply of proper capacity can result in a tripped breaker, blown fuse, damage to existing wiring, or component failure. This could lead to heat generation or fire.
- **THE ICEMAKER MUST BE GROUNDED.** The icemaker is equipped with a NEMA 5-15 three-prong grounding plug  to reduce the risk of potential shock hazards. It must be plugged into a properly grounded, independent 3-prong wall outlet. If the outlet is a 2-prong outlet, it is your personal responsibility to have a qualified electrician replace it with a properly grounded, independent 3-prong wall outlet. Do not remove the ground prong from the power cord and do not use an adapter plug. Failure to properly ground the icemaker could result in death or serious injury.
- Do not use an extension cord.
- Do not use an icemaker with a damaged power cord. The power cord should not be altered, jerked, bundled, weighed down, pinched, or tangled. Such actions could result in electric shock or fire. To unplug the icemaker, be sure to pull the plug, not the cord, and do not jerk the cord.
- Do not place fingers or any other objects into the ice discharge opening.

SRC

- The remote condensing unit requires an independent power supply of proper capacity. See the nameplate for electrical specifications. Failure to use an independent power supply of proper capacity can result in a tripped breaker, blown fuse, damage to existing wiring, or component failure. This could lead to heat generation or fire.
- Electrical connection must be hard-wired to the remote condensing unit and must meet national, state, and local electrical code requirements. Failure to meet these code requirements could result in death, electric shock, serious injury, fire, or damage.
- **THE REMOTE CONDENSER UNIT MUST BE GROUNDED.** The power supply and ground connection to the remote condenser unit are supplied from the icemaker. Failure to properly ground the remote condenser unit could result in death or serious injury.
- Wire routing (conduit) and disconnect (if required) must meet national, state, and local electrical code requirements. Failure to meet these code requirements could result in death, electric shock, serious injury, fire, or damage.

NOTICE

- Follow the instructions in this manual carefully to reduce the risk of costly water damage.
- In areas where water damage is a concern, install in a contained area with a floor drain.
- Install the appliance in a location that stays above freezing. Normal operating ambient temperature must be within 45°F to 100°F (7°C to 38°C).
- Do not leave the icemaker on during extended periods of non-use, extended absences, or in sub-freezing temperatures. To properly prepare the icemaker for these occasions, follow the instructions provided in the instruction manual.
- Do not place objects on top of the appliance.
- The dispenser unit/ice storage bin is for ice use only. Do not store anything else in the dispenser unit/ice storage bin.

I. Construction and Water/Refrigeration Circuit Diagram

A. Construction

1. Icemaker

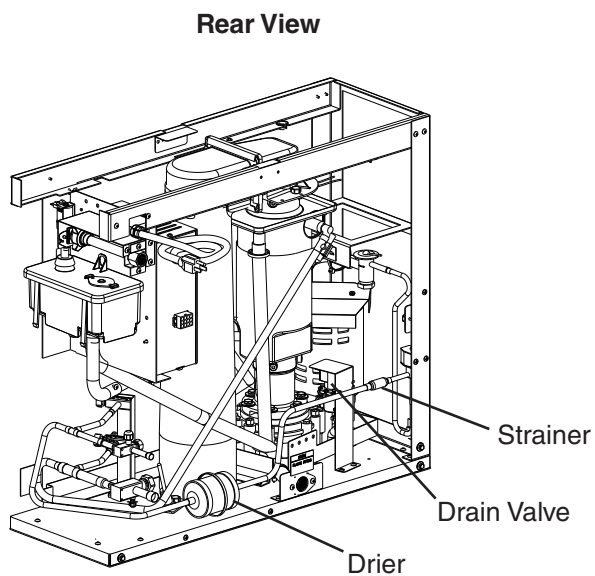
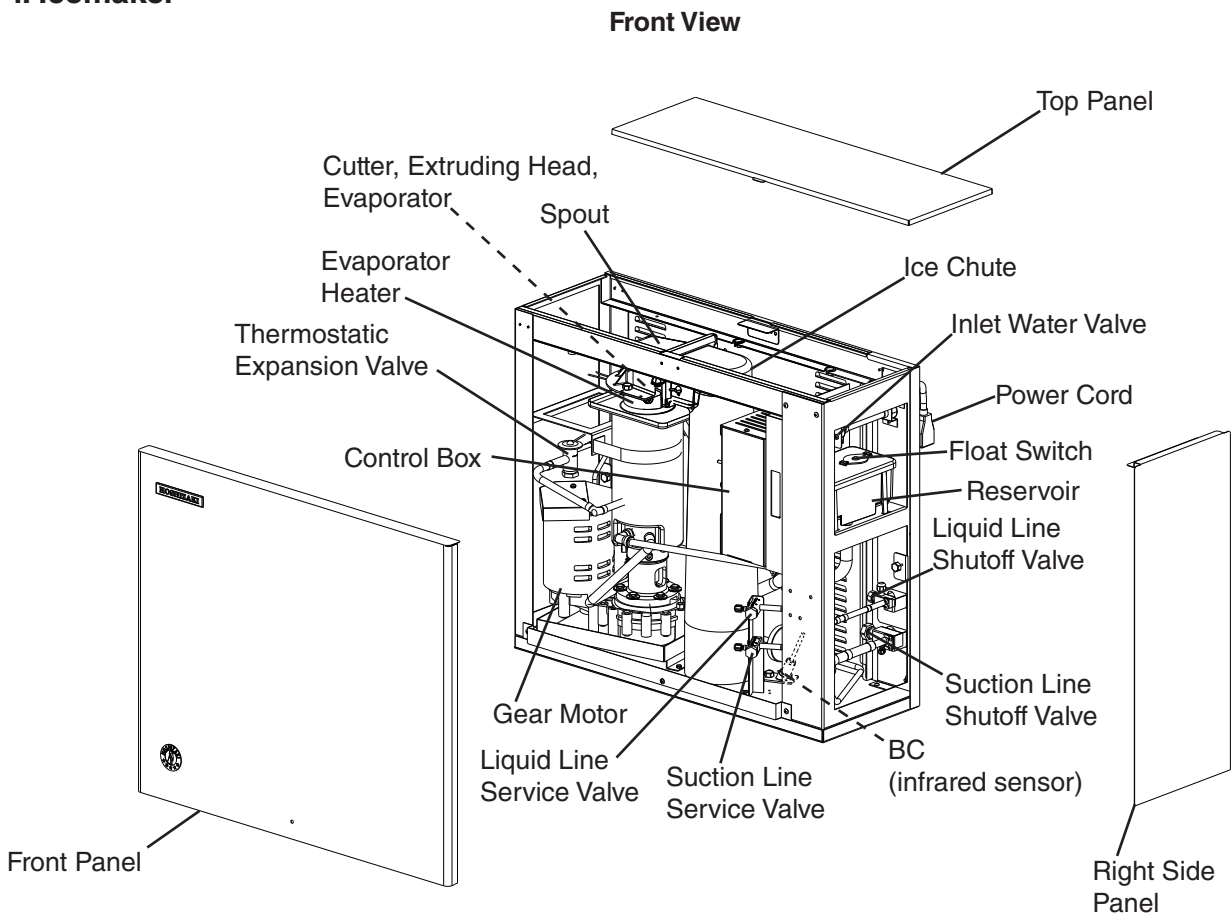

Model Shown: FS-1001MLJ-C

2. Condensing Unit

a) SRC-10J

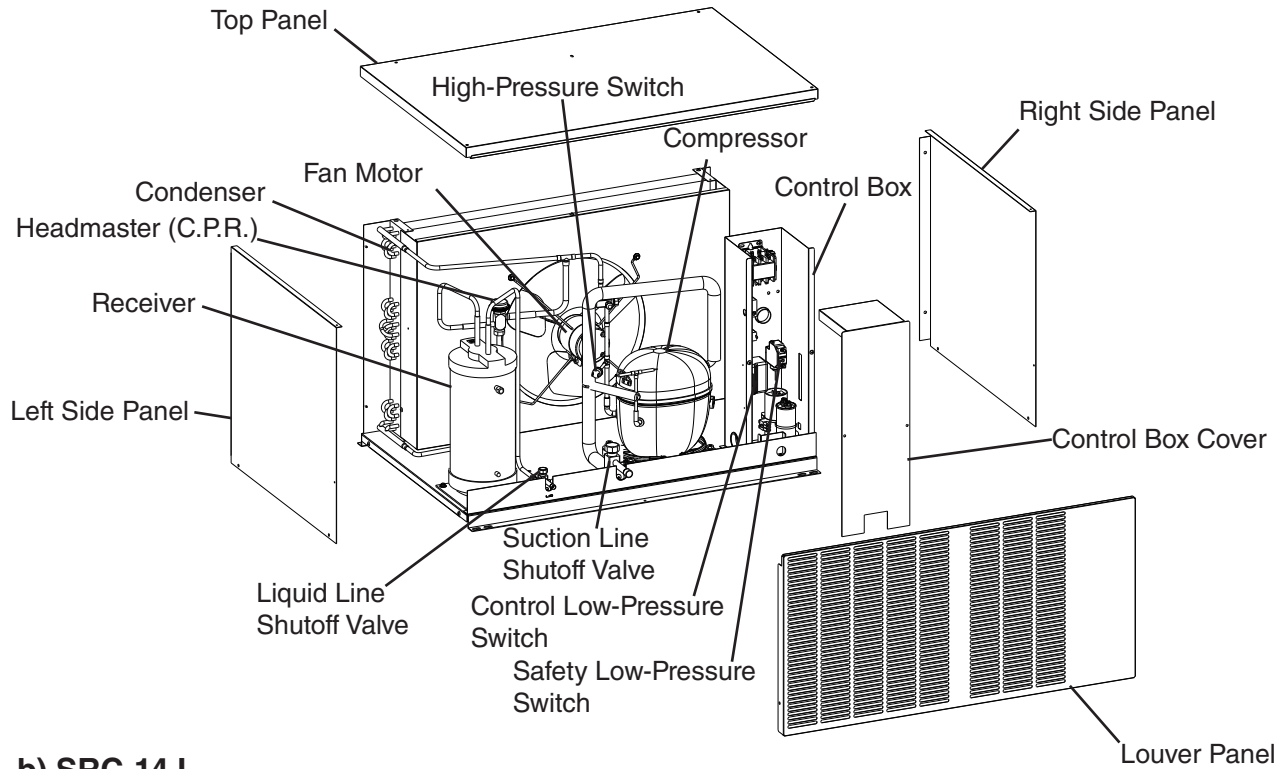

b) SRC-14J

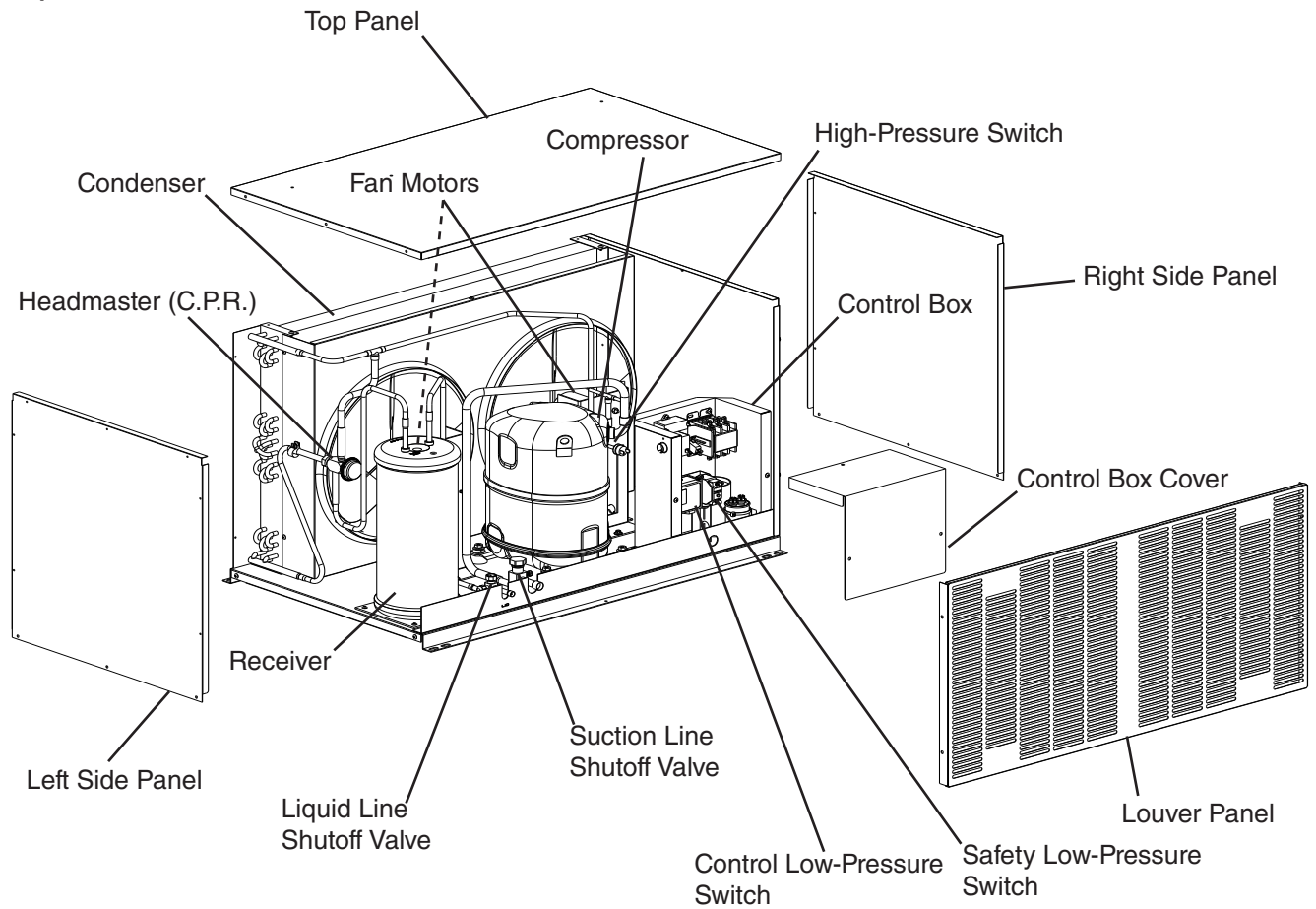

3. Icemaking Unit

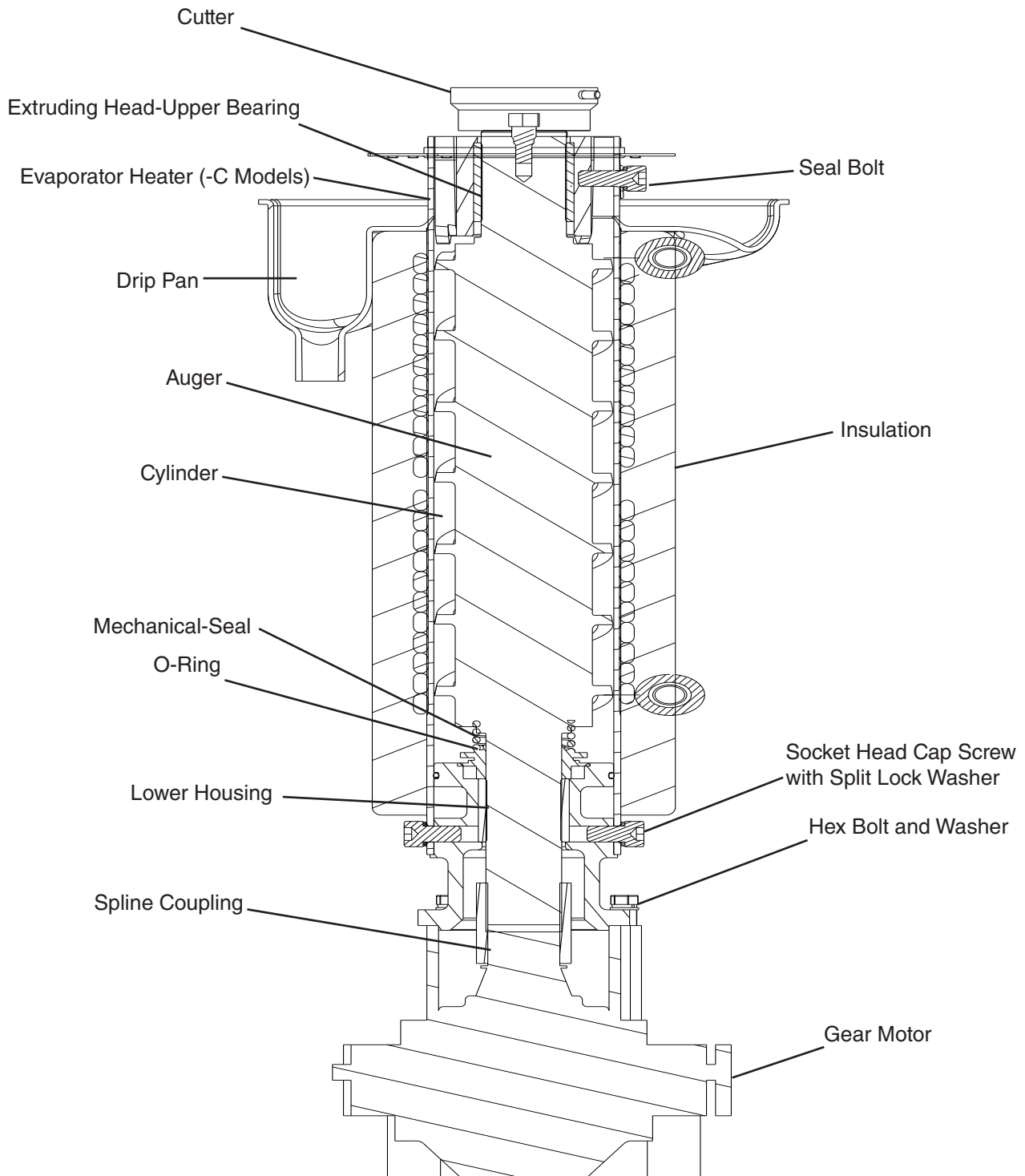

Model Shown: FS-1500MAJ-C

B. Water/Refrigeration Circuit Diagram

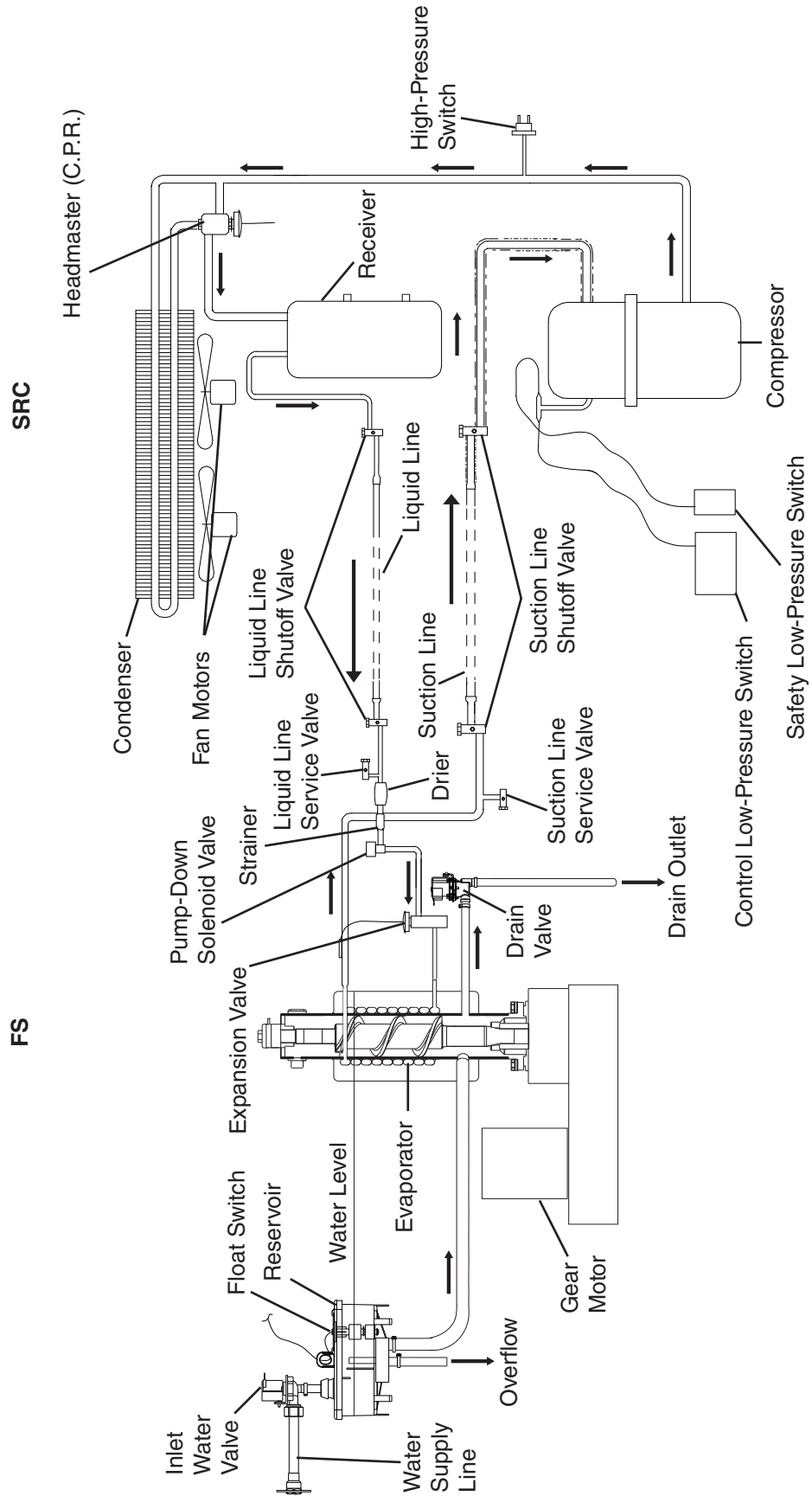

II. Sequence of Operation and Service Diagnosis

A. Sequence of Operation Flow Chart

1. Operation Flow Chart

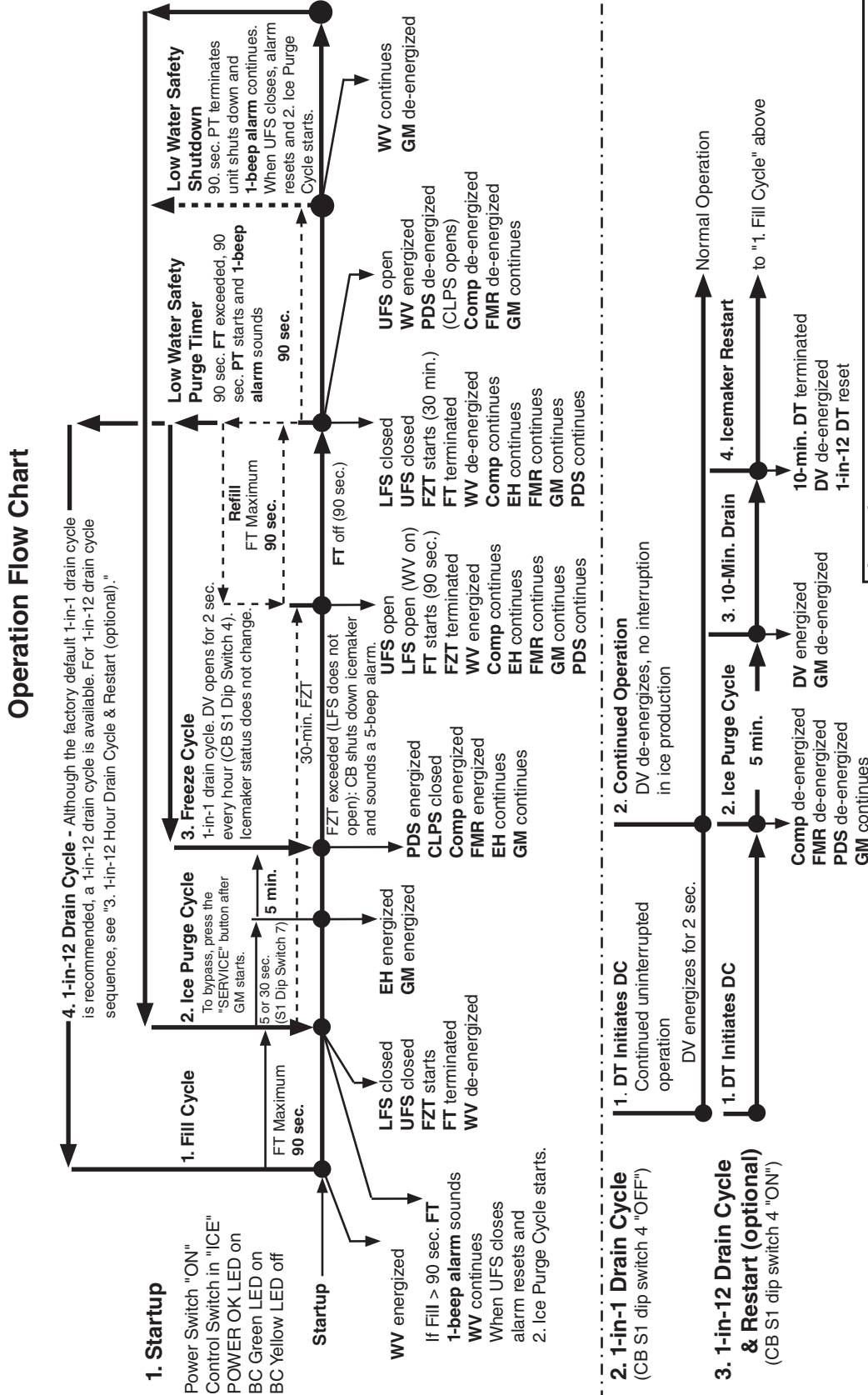

Legend:

FMR	fan motor-remote
FT	fill timer (low water safety)
FZT	freeze timer
GM	gear motor
LFS	lower float switch
PDS	pump-down solenoid valve
PT	purge timer
UFS	upper float switch
WV	inlet water valve
BC	bin control (infrared sensor)
CB	control board
CCH	crankcase heater
CLPS	control low-pressure switch
Comp	compressor
DC	drain cycle
DT	drain timer
DV	drain valve
EH	evaporator heater

Note: CCH energizes when power is supplied to SRC.
 CCH de-energizes when Comp is energized.
 See "VII.B.3. SRC-10J Condensing Unit."

2. Shutdown Flow Chart

Shutdown Flow Chart

1. BC (infrared sensor) Shutdown

If BC fails to shutdown the icemaker.
See "I.I.D. Bin Control Check."

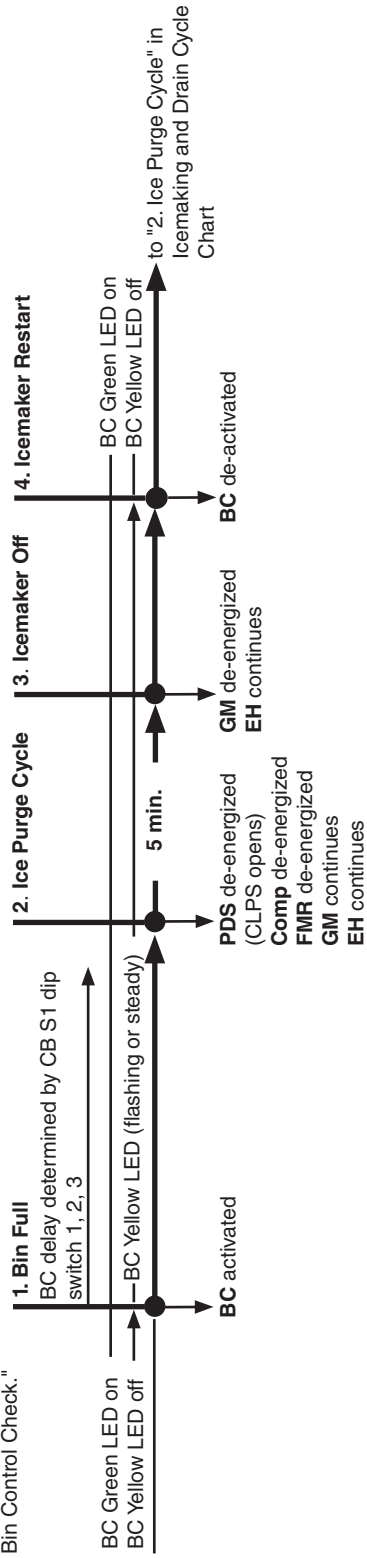

B. Service Diagnosis

WARNING

- The appliance should be diagnosed and repaired only by qualified service personnel to reduce the risk of death, electric shock, serious injury, or fire.
- Risk of electric shock. Use extreme caution and exercise safe electrical practices.
- Moving parts (e.g., fan blade) can crush and cut. Keep hands clear.
- **CHOKING HAZARD:** Ensure all components, fasteners, and thumbscrews are securely in place after the appliance is serviced. Make sure that none have fallen into the dispenser unit/storage bin.
- Make sure all food zones in the icemaker and dispenser unit/storage bin are clean after the unit is serviced.

1. Ice Production Check

To check production, prepare a bucket or pan to catch the ice and a set of scales to weigh the ice. After the appliance has operated for 10 to 20 min., catch the ice production for 10 min. Weigh the ice to establish the batch weight. Multiply the batch weight by 144 for the total production in 24 hours. When confirming production or diagnosing low production, reference production information found in "VII.A. Specification and Performance Data Sheets."

2. Diagnostic Procedure

This diagnostic procedure is a sequence check that allows you to diagnose the electrical system and components. Before proceeding, check for correct installation, proper voltage per appliance nameplate, and adequate water pressure (10 PSIG to 113 PSIG). Check that both the 24VAC circuit fuse and the 115VAC GM fuse are good.

Note: • When checking high voltage (115VAC), always choose a neutral (W) wire to establish a good neutral connection.

- When checking low voltage (24VAC), always choose a neutral (LBU) wire to establish a good neutral connection.
 - When checking control board DC voltage (5VDC), always place the red positive test lead from the multimeter to CB K5 pin closest to CB K4 connector. See "II.C. Control Board Check."
 - When checking BC (infrared sensor) (20VDC), check that BC (infrared sensor) green LED is on. This green LED confirms 20VDC power from CB K6 to BC (infrared sensor) and remains on constantly. If green LED is not on, check for 20VDC from CB K6 #1 (DBU) to CB K6 #3 (BR). See "II.D. Bin Control Check."
 - To speed up the diagnostic process, the 5-min. ice purge cycle may be bypassed by pressing the "SERVICE" button on the control board after the gear motor starts. **WARNING! Risk of electric shock. Care should be taken not to touch live terminals.**
 - If the icemaker is in alarm, see "III.A.2. LED Lights and Audible Alarm Safeties."
 - EH energizes when "GM" LED turns on.
 - CB X1 relay energizes PDS. After PDS energizes, CPLS closes, then MC energizes, energizing Comp and FMR.
 - CB monitors the following switches with 5VDC during the icemaking process: Control Switch (CS), Compressor Control Relay (CCR), Float Switch (FS). When 5VDC is present across any of these switches, the switch is open.
- 1) Remove the front panel, then move the power switch to the "OFF" position. Move the control switch to the "DRAIN" position, then move the power switch back to the "ON" position. Replace the front panel in its correct position.
 - 2) Allow the water system to drain for 5 min.
 - 3) Remove the front panel. Move the power switch to the "OFF" position, then unplug the appliance from the electrical outlet.
 - 4) Remove the control box cover and access CB.
 - 5) Check the CB S1 dip switch settings, see "III.B.1. Default Dip Switch Settings" to assure that they are in the correct positions. For proper operation of BC (infrared sensor), confirm that S1 dip switch 7 is in the "ON" position.

6) **Startup – CB "POWER OK" LED is on.** Plug the icemaker back into the electrical outlet, then move the power switch to the "ON" position. Move the control switch to the "ICE" position. CB "POWER OK" LED and BC green LED turn on.

Diagnosis CB "POWER OK" LED: If CB "POWER OK" LED is off, check for proper supply voltage (115VAC) input to CT. If 115VAC is not present, check the power switch and breaker. Next, check for proper 24VAC output voltage from CT. Check CB K8 #1 (W/R) to #2 (LBU) for 24VAC. If 24VAC is not present and 1A 24VAC fuse is good, replace CT. If 24VAC is present and CB "POWER OK" LED is off, replace CB.

Diagnosis BC (infrared sensor): Check that BC green LED is on. If CB "POWER OK" LED is on and BC green LED is off, check CB K6 #1 (DBU) to CB K6 #3 (BR) for 20VDC. If 20VDC is not present, confirm S1 dip switch 7 is in the "ON" position. If S1 dip switch 7 is in the "ON" position and 20VDC is not present, replace CB. If BC yellow LED is on or flashing, move ice away from lens. If no ice is present, clean the lens with a warm, clean damp cloth. If BC yellow LED is still on or flashing after cleaning the lens, replace BC.

7) **Fill Cycle – "WTRIN" LED is on.** Reservoir is empty and LFS and UFS are open. 90-sec. FT starts. WV energizes and fill cycle starts. LFS closes. Nothing occurs at this time. Reservoir continues to fill until UFS closes. When UFS closes, FT terminates, WV de-energizes, 90-sec. FT is terminated, and CB "WTRIN" LED turns off. 30-min. FZT and 30-sec. GM delay timer start. If UFS remains open longer than 90 sec. after LFS opens, FT exceeded and CB sounds a 1-beep alarm. WV remains energized until UFS closes. Alarm resets automatically when UFS closes.

Diagnosis: If reservoir is empty and "WTRIN" LED is off, confirm LFS status. See "II.F.1. Float Switch Check."

If LFS is open and "WTRIN" LED is off, replace CB. If "WTRIN" LED is on, check that the reservoir fills. If not, check water supply line shut-off valve, water filters, and WV screen. If "WTRIN" LED is on and WV is off, check CB K2 #8 (O) to a neutral (LBU) for 24VAC. If 24VAC is not present, check CB K2 #9 (W/R) to a neutral (LBU) for 24VAC. If 24VAC is present on CB K2 #9 (W/R) and not on CB K2 #8 (O), replace CB. If 24VAC is present on CB K2 #8 (O), check continuity through WV solenoid. If open, replace WV. If WV is energized and refill exceeds FT with no water in the reservoir, check for DV leaking. If reservoir is full and overflowing check for open UFS.

See "II.F.1. Float Switch Check." If UFS is closed, check that WV de-energizes.

If not, check CB K2 #8 (O) to a neutral (LBU) for 24VAC. If 24VAC is present, replace CB. If WV de-energizes and water continues to fill the reservoir, replace WV.

8) **Ice Purge Cycle – "GM" LED is on.** 30-sec. GM delay timer terminates. GM, EH, and CCR energize. Once CCR energizes, 5VDC circuit closes through CCR terminal #3 (W/O) and terminal #5 (W/O) and CB K9 #5 (W/O) and K9 #6 (W/O). After 5VDC circuit closes, 5-min. ice purge timer starts. To bypass the 5-min. Ice Purge Cycle, press the "SERVICE" button on CB after the "GM" LED turns on. **WARNING! Risk of electric shock. Care should be taken not to touch live terminals.**

Diagnosis: If "GM" LED is off, check that UFS closes and WV de-energizes. If UFS is closed, 30 sec. has passed, and "GM" LED remains off, replace CB. If "GM" LED is on and GM is off, check CB K1 #3 (BK) to a neutral (W) for 115VAC. If 115VAC is not present, check 115VAC power supply. If 115VAC is present, check CB K1 #2 (W/BK or P) to a neutral (W). If 115VAC is present on CB K1 #3 (BK) and not on CB K1 #2 (W/BK or P), replace CB. If 115VAC is present on CB K1 #2 (W/BK or P), check GM fuse, GM internal protector, GM windings and capacitor, and GM coupling between auger and GM. When GM energizes, CCR energizes starting 5-min. ice purge timer.

9) **Freeze Cycle – "COMP" and "GM" LEDs are on.** Note: CB X1 relay energizes the PDS (pump-down solenoid) not the MC (magnetic contactor). The 5-min. ice purge timer terminates. GM, EH, and CCR continue. PDS energizes. Once the refrigeration circuit low-side pressure reaches 29 PSIG, CLPS closes, energizing MC, MC then energizes Comp and FMR. CCH de-energizes. Ice production starts 4 to 6 min. after Comp energizes depending on ambient and water conditions. As ice is produced, the water level in the reservoir drops. UFS opens. Nothing occurs at this time. When LFS opens, WV energizes and refill cycle begins, FZT terminates, and FT starts.

FZT: 30-Min. Freeze Safety Timer – FZT starts when UFS closes and terminates when LFS opens. If LFS does not open within 30 min. of UFS closing, CB shuts down the icemaker and sounds a 5-beep alarm. See "III.A.2. LED Lights and Audible Alarm Safeties." To reset, turn the power supply off and on again. See "II.G. Diagnostic Tables" for troubleshooting details.

Icemaker Diagnosis (CCR): 5-min. ice purge timer terminates, CB "COMP" LED is on and PDS energizes. If not, check for 5VDC between CB K5 connector pin closest to CB K4 connector and CB K9 connector #5 (W/O). If 5VDC is not present, replace CB. If 5VDC is present, check for 5VDC between CB K5 connector pin closest to CB K4 connector and CB K9 connector #6 (W/O). If 5VDC is present and CB "Comp" LED is off (PDS not energized), replace CB. If 5VDC is not present, check for 115VAC between CCR terminal #7 (O) to CCR terminal #8 (W) for 115VAC. If 115VAC is not present (GM not energized), see step 8 above. If 115VAC is present and CCR contacts are open (5VDC present between terminals #3 (W/O) and #5 (W/O)), check CCR solenoid voltage and solenoid continuity. Replace CCR if necessary.

Icemaker Diagnosis (PDS): If "COMP" LED is on and PDS is not energized, check CB X1 relay black (BK) wire to a neutral (W) and CB X1 relay violet or dark blue (V or DBU) wire to a neutral (W) for 115VAC. If 115VAC is present on CB X1 black (BK) wire and not on CB X1 violet or dark blue (V or DBU) wire, replace CB. If 115VAC is present on CB X1 violet or dark blue (V or DBU) wire and PDS is not energized, check for 115VAC at PDS (V or DBU) to a neutral (W) for 115VAC. If 115VAC is present and PDS is not energized, check PDS solenoid for continuity. If open or if PDS is sticking closed, replace PDS.

Condensing Unit Diagnosis: Confirm that CLPS closes. Once CLPS closes, MC energizes, energizing Comp and FMR. If not, check condensing unit 208-230VAC power supply, breakers, disconnects. Next, confirm 115VAC from CLPS (BR) wire to neutral (W). If 115VAC is not present, check wiring connections and power supply.

CLPS: When PDS is energized, CLPS closes when refrigeration circuit low-side pressure reaches 29 PSIG. If CLPS is open, check that refrigeration circuit low-side pressure has reached 29 PSIG. If refrigeration circuit low-side pressure is too low, confirm proper TXV operation, check for refrigerant restrictions (drier, PDS), and correct refrigerant charge. Recover, evacuate, and recharge if necessary. If refrigeration circuit low-side pressure reaches 29 PSIG and CLPS does not close, replace CLPS.

SLPS: If SLPS is open, manually reset SLPS. If manually resetting SLPS does not close contacts, replace SLPS. After resetting, confirm proper TXV operation, check for refrigerant restriction (drier, PDS), and correct refrigerant charge. Recover, evacuate, and recharge if necessary.

HPS: If HPS is open, HPS automatically resets when refrigeration circuit high-side pressure is within an acceptable range. If HPS does not reset (open), allow pressures to equalize and HPS to reset. If refrigeration circuit high-side pressure does not drop, recover, evacuate, and recharge if necessary. Before restarting the appliance, check for dirty or clogged condenser. Once the appliance is restarted, check for proper FMR operation and fan blade for binding. Check receiver, service valves, PDS, and drier for refrigeration circuit restriction. Also check for proper HM operation. If high-side refrigerant pressures have returned to an acceptable range and HPS does not close, replace HPS.

MC: If MC energizes and Comp does not energize, check for 115VAC at MC C2 (O) to neutral (W). If 115VAC is not present, check CLPS, SLPS, and HPS contacts. If 115VAC is present, check MC coil continuity. If open, replace MC. If closed, check MC L1 and MC L2 to a neutral (W) for 115VAC. If 115VAC is not present on either L1 or L2, check incoming power supply. If 115VAC is present on both L1 and L2 and Comp does not start, check MC T1 (BK) to MC T2 (R) for 208-230VAC. If 208-230VAC is not present, replace MC. If 208-230VAC is present, check Comp start relay, start capacitor, run capacitor, and Comp motor windings. If FMR does not energize, check MC T3 (DBU) to a neutral (W) for 115VAC. If 115VAC is present and FMR does not energize, check fan motor capacitors and motor windings. If 115VAC is not present, replace MC.

10) **Refill Cycle – "GM", "COMP", and "WTRIN" LEDs are on.**

LFS opens. WV energizes and FT starts. GM, CCR, EH, PDS, MC, Comp, and FMR continue. LFS closes. Nothing occurs at this time. Reservoir continues to fill until UFS closes. When UFS closes, WV de-energizes, 90-sec. FT terminates, and 30-sec. FZT starts. If UFS remains open longer than 90-sec. after LFS opens, FT exceeded and CB sounds a 1-beep alarm. WV remains energized until UFS closes. Alarm resets automatically when UFS closes.

Diagnosis – Confirm that the water level has dropped and the UFS and LFS are open. See "II.F.1. Float Switch Check." Check that "WTRIN" LED is on. If LFS is open and "WTRIN" LED is off, replace CB. If "WTRIN" LED is on, check that the reservoir fills. If not, check water supply line shut-off valve, water filters, and WV screen. If "WTRIN" LED is on and WV is off, check CB K2 #8 (O) to a neutral (LBU) for 24VAC. If 24VAC is not present, check CB K2 #9 (W/R) to a neutral (LBU) for 24VAC. If 24VAC is present on CB K2 #9 (W/R) and not on CB K2 #8 (O), replace CB. If 24VAC is present on CB K2 #8 (O), check continuity through WV solenoid. If open, replace WV. If WV is energized and refill exceeds FT with no water in the reservoir, check for DV leaking. If reservoir is full and overflowing check for open UFS. See "II.F. Float Switch Check and Cleaning." If UFS is closed, check that WV de-energizes. If not, check CB K2 #8 (O) to a neutral (LBU) for 24VAC. If 24VAC is present, replace CB. If WV de-energizes and water continues to fill the reservoir, replace WV.

Note: Each time UFS closes, 30-min. freeze timer starts. The 30-min. freeze timer resets when UFS closes again. If UFS does not close again within 30-min., CB shuts down the unit and sounds a 5-beep alarm every 5 sec.

See "III.A.2 LED Lights and Audible Alarm Safeties."

FT: 90-Sec. Low Water Safety Timer – When LFS opens, 90-sec. low water safety timer starts. If UFS does not close within 90 sec. after LFS opens (FT exceeded), CB sounds a 1-beep alarm and a 90-sec. shutdown cycle starts.

See "III.A.2. LED Lights and Audible Alarm Safeties." PDS de-energizes. Refrigeration circuit low-side pressure drops to 9 PSIG, opening CLPS. CLPS opens, de-energizing MC, which de-energizes Comp and FMR. GM, CCR, and EH continue. 90-sec. purge timer terminates. GM, EH, and CCR de-energize. WV and 1-beep alarm continue until UFS closes.

11) Drain Cycle

- a) **1-in-1 Drain Cycle:** DV energizes once every hour when the 1-in-1 drain cycle is activated (S1 dip switch 4 in the "OFF" position (factory default position)). GM and PDS continue. DV energizes for 2 sec. every hour. This setting is recommended for optimum icemaker performance. The 1-in-1 drain cycle allows any sediment to drain from the evaporator without interrupting the icemaking process.
- b) **1-in-12 Drain Cycle (optional):** DV energizes once every 12 hours when the 1-in-12 drain cycle is activated (S1 dip switch 4 in the on position (optional)). 12-hour drain cycle timer terminates, PDS de-energizes, GM continues. The 5-min. ice purge timer starts. When the 5-min. ice purge timer terminates, GM de-energizes. 10-min. DT starts, DV energizes. After 10-min. DT terminates, DV de-energizes and 12-hour drain cycle timer starts. Icemaking process restarts.
- c) **Manual Drain:** Manual drain is used when servicing evaporator components and cleaning and sanitizing the unit. When the unit is making ice and the control switch is moved to the "DRAIN" position, there is a 3 sec. delay, then PDS de-energizes and the 5-min. ice purge timer starts. When the 5-min. ice purge timer terminates, GM de-energizes. DV energizes to drain the evaporator and reservoir. To avoid the 5-min. shutdown delay, turn off the power supply, then move the control switch to the "DRAIN" position. Turn on the power supply. DV energizes to drain the evaporator and reservoir. DV de-energizes when the control switch is moved to the "ICE" position

- 12) **Shutdown – BC (infrared sensor):** When ice activates BC, yellow LED starts flashing when ice is at the outer limit of its range and turns steady as ice nears. After BC yellow LED turns on (flashing or steady), BC shutdown delay timer (S1 dip switch 1, 2, 3) starts. For a typical dispenser unit application, a 100-sec. shutdown delay is recommended. When used with a standard Hoshizaki storage bin, any shutdown delay setting is acceptable. See "III.B.2. BC (Infrared Sensor) Shutdown Delay (S1 dip switch 1, 2, 3)." Once BC shutdown delay timer terminates, PDS de-energizes and the 5-min. ice purge timer starts. Unit is in pump-down mode. When the refrigerant low-side pressure drops to 9 PSIG, CLPS opens, MC de-energizes, de-energizing Comp and FMR. CCH energizes. When the 5-min. ice purge timer terminates, GM, EH, CCR de-energize. **Icemaker Diagnosis:** BC yellow LED not flashing or on with ice near. See "II.D. Bin Control Check." PDS remains energized after BC shutdown delay timer terminates. Check for 115VAC from CB X1 relay (V or DBU) wire to neutral (W). If 115VAC is present, replace CB. If 115VAC is not present, check PDS for mechanical failure.

Condensing Unit Diagnosis: When PDS de-energizes and closes, pump-down starts. Confirm refrigerant low-pressure drops to 9 PSIG and CLPS opens. If refrigerant low-pressure reaches 9 PSIG and CLPS does not open, replace CLPS. If Comp and FMR remain energized after CLPS opens, replace MC.

Legend: **BC**—bin control (infrared sensor); **CB**—control board; **CCH**—crankcase heater; **CCR**—compressor control relay; **CLPS**—control low-pressure switch; **Comp**—compressor; **CT**—control transformer; **DV**—drain valve; **EH**—evaporator heater; **FMR**—fan motor-remote; **FT**—90-sec. low water safety timer; **FZT**—30-min. freeze safety timer; **GM**—gear motor; **HM**—headmaster (C.P.R.); **HPS**—high-pressure switch; **LFS**—lower float switch; **MC**—magnetic contactor; **PDS**—pump-down solenoid valve; **SLPS**—safety low-pressure switch; **UFS**—upper float switch; **WV**—inlet water valve

C. Control Board Check

Before replacing a control board that does not show a visible defect and that you suspect is bad, always conduct the following check procedure. This procedure will help you verify your diagnosis.

- 1) Check CB S1 dip switch settings to assure that they are in the factory default position. For factory default settings, see "III.B.1. Default Dip Switch Settings."
 Note: S1 dip switch 7 determines bin control application:
BC (infrared sensor): S1 dip switch 7 in the "ON" position.
BC (mech. stand-alone or backup(only)) (Standard Ice Storage Bin): S1 dip switch 7 in the "OFF" position. **WARNING! On CB 2A8054-01, do not put S1 dip switch 9 in the "OFF" position when S1 dip switch 7 is in the "OFF" position.**
- 2) Move the power switch to the "ON" position and move the control switch to the "ICE" position. The CB "POWER OK" LED turns on. **Diagnosis "POWER OK" LED:** Check that the CB "POWER OK" LED is on. If not, check for proper supply voltage (115VAC) input to the control transformer (power switch, breaker, and fuse). Next, check for proper low-voltage (24VAC) output from the control transformer and the 1A fuse is good. Check for 24VAC at CB K8 #1 (W/R) to CB K8 #2 (LBU). If 24VAC is present and CB "POWER OK" LED is off, replace CB.
- 3) **BC (infrared sensor) Power Supply (K6 connector):** CB supplies 20VDC to BC and BC green LED is on. **Diagnosis:** Check that BC green LED is on. If not, check for 20VDC between CB K6 #1 (DBU) and CB K6 #3 (BR). See Fig. 1. If 20VDC is not present, replace CB. If 20VDC is present, confirm that the yellow LED is not flashing or steady. If BC yellow LED is on or flashing, move ice away from lens. If no ice is present, clean the lens with a warm, clean damp cloth. If cleaning the lens does not work, replace BC (infrared sensor).

BC (infrared sensor) (20VDC)
 Closed
 20VDC K6 #1 (DBU) to K6 #3 (BR)
 20VDC K6 #1 (DBU) to K6 #2 (W)
 0VDC K6 #2 (W) to K6 #3 (BR)

BC (infrared sensor) (20VDC)
 Open (yellow LED flashing or steady)
 20VDC K6 #1 (DBU) to K6 #3 (BR)
 0VDC K6 #1 (DBU) to K6 #2 (W)
 20VDC K6 #2 (W) to K6 #3 (BR)

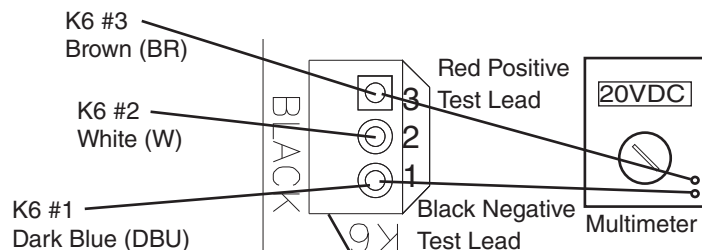

Fig. 1 • K6 Connector
 BC (Infrared Sensor)

4) 5VDC Output Checks:

CB K9 Connector: Control Switch (CB K9 #1 and #2) (open contacts for icemaking, closed contacts for drain), Jumper (CB K9 #3 and #4), Compressor Control Relay (K9 #5 and #6).

Float Switch (K8 #5 (common), #6 (lower), and #7 (upper)).

When checking 5VDC control voltage, always place the red positive test lead from the multimeter to the CB white K5 pin closest to the CB red K4 connector. See Fig. 2.

Then place the black negative test lead from the multimeter to the corresponding pin to complete the 5VDC check.

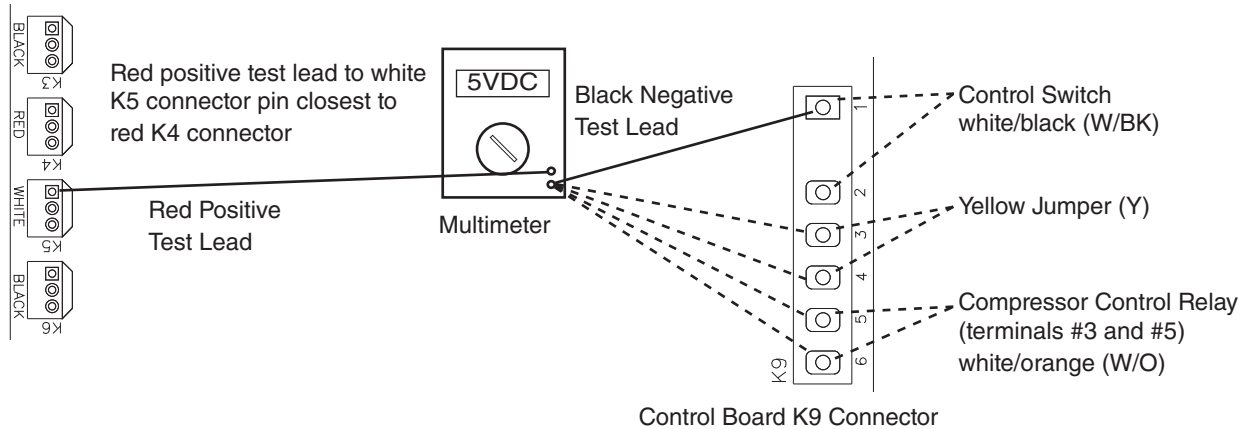
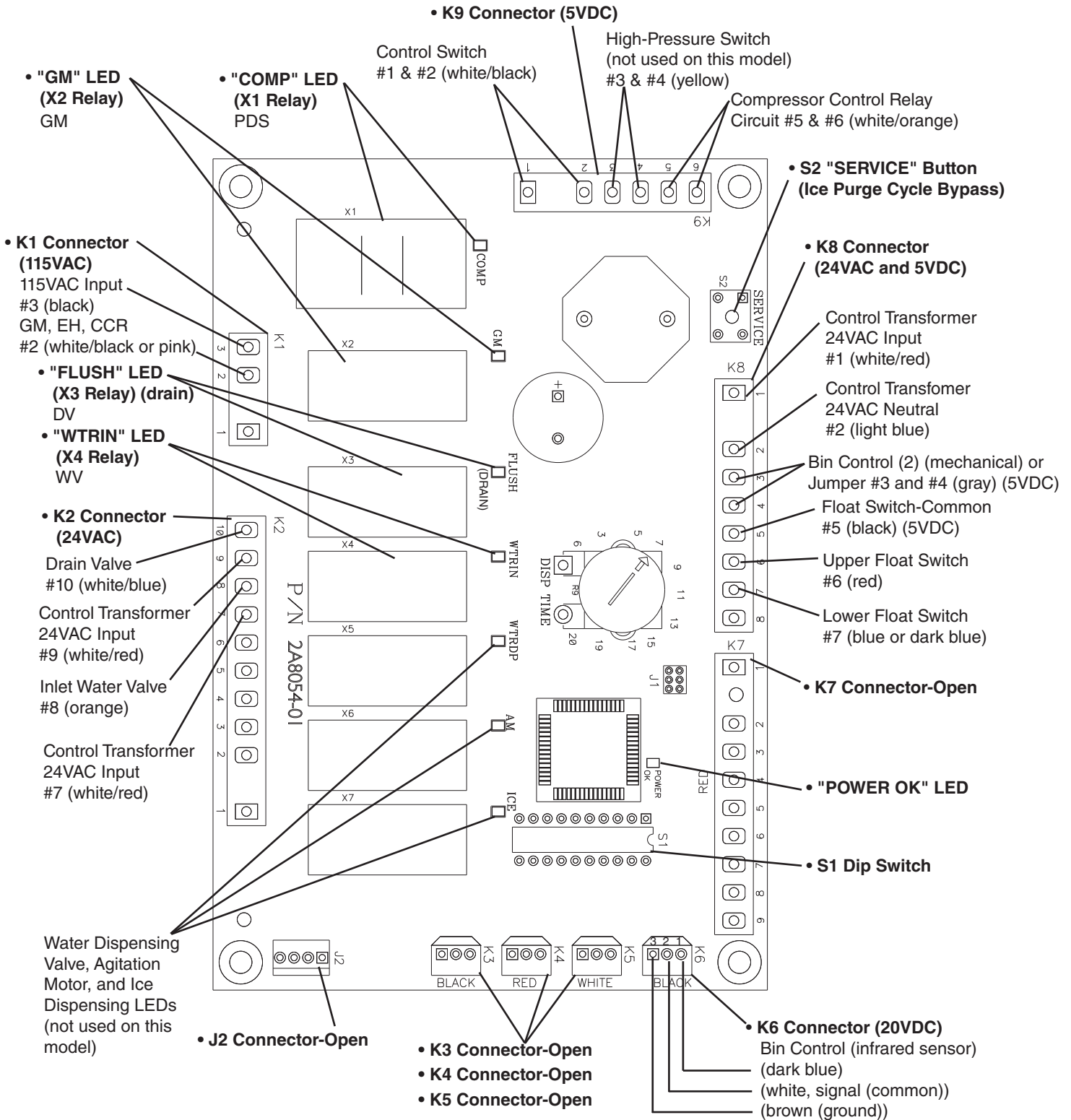

Fig. 2

- a. **Control Switch** – CB K9 #1 (W/BK) and CB K9 #2 (W/BK): 5VDC is present between CB white K5 connector, pin closest to CB red K4 connector and CB K9 #1 (W/BK) at all times. If 5VDC is not present, replace CB. When the control switch is in the "ICE" position, the control switch contacts are open. 0VDC is present between CB white K5 connector, pin closest to CB red K4 connector and CB K9 #2 (W/BK). When in the "ICE" position, 5VDC is present from CB K9 #1 (W/BK) to CB K9 #2 (W/BK). When the control switch is in the "DRAIN" position, the control switch contacts are closed. 5VDC is present between CB white K5 connector, pin closest to CB red K4 connector, to CB K9 #1 (W/BK) or #2 (W/BK). If 5VDC is not present, replace CB. 0VDC is present from CB K9 #1 (W/BK) to CB K9 #2 (W/BK).
- b. **Compressor Control Relay (CCR)** – CB K9 #5 (W/O) and CB K9 #6 (W/O): 5VDC is present from CB white K5 connector, pin closest to CB red K4 connector, to CB K9 #5 (W/O) at all times. If 5VDC is not present, replace CB. When CCR terminals #3 (W/O) and #4 (W/BK) are open (CCR de-energized), 5VDC is present between CB K9 #5 (W/O) and CB K9 #6 (W/O). When CCR terminals #3 (W/O) and #4 (W/BK) are closed (CCR energized), 5VDC is present between CB K9 #5 (W/O) and CB K9 #6 (W/O). When CCR terminals #3 (W/O) & #5 (W/O) are open CB may be in an 8-beep alarm. See "III.A.2. LED Lights and Audible Alarm Safeties."

- c. **Float Switch (LFS and UFS)** – CB K8 #5 (BK) (common), CB K8 #6 (R) (upper), and CB K8 #7 (BU) (lower): 5VDC is present from CB white K5 connector pin closest to CB red K4 connector to CB K8 #5 (BK) (common) at all times. If not, replace CB. 5VDC is present from CB white K5 connector pin closest to CB red K4 connector to CB K8 #6 (R) (upper) and CB K8 #7 (BU) (lower) when FS is open. If 5VDC is present between CB K8 #5 (BK) and CB K8 #6 (R) (upper) or CB K8 #7 (BU) (lower), FS is open. For further FS diagnostics, see "II.F. Float Switch Check and Cleaning."
- 5) **Fill "WTRIN" LED is on:** 24VAC is present at CB K2 #9 (W/R) at all times. If not, confirm 24VAC from CB K2 #9 (W/R) to a neutral (LBU). When LFS open at startup or opens during normal operation, "WTRIN" LED turns on, fill timer (FT) starts, freeze timer (FZT) terminates (only during normal operation), and WV energizes. If LFS is open and "WTRIN" LED is off, confirm LFS status. See "II.F. Float Switch Check and Cleaning." If LFS is open and "WTRIN" LED is off, replace CB. If "WTRIN" LED is on and WV is not energized, check for 24VAC at CB K2 #8 (O) to a neutral (LBU). If 24VAC is not present on CB K2 #8 (O), replace CB. "WTRIN" LED turns off once UFS closes. If not, confirm UFS status. See "II.F. Float Switch Check and Cleaning." If UFS is closed and "WTRIN" LED is on, replace CB. If "WTRIN" LED is off and WV is open, check for 24VAC at CB K2 #8 (O). If 24VAC is present at CB K2 #8 (O), replace CB. If 24VAC is not present, check WV diaphragm.
- 6) **Ice Purge Cycle "GM" LED is on:** When UFS closes, GM delay timer starts (5 or 30 sec. depending on CB S1 dip switch #7). Once GM delay timer terminates, "GM" LED turns on, GM and EH energize and 5-min. ice purge timer starts. If GM does not energize 30 sec. after UFS closes, confirm UFS status. See "II.F. Float Switch Check and Cleaning." If UFS is closed and "GM" LED does not turn, replace CB. If "GM" LED is on and GM and EH are off, check for 115VAC from CB K1 #3 (BK) to a neutral (W). If not, check 115VAC power supply connections from power switch. If 115VAC is present, check for 115VAC from CB K1 #2 (W/BK or P) to a neutral (W). If 115VAC is present on CB K1 #3 (BK) and not on CB K1 #2 (W/BK or P), replace CB.
- 7) **Freeze Cycle "GM" and "COMP" LED are on:** The 5-min. ice purge timer terminates or the ice purge cycle bypass button ("SERVICE") is pressed, "COMP" LED turns on. To bypass the 5-min. Ice Purge Cycle, press the "SERVICE" button on CB after the "GM" LED turns on. **WARNING! Risk of electric shock. Care should be taken not to touch live terminals.** 115VAC is present between CB X1 relay power supply black (BK) and neutral (W) at all times. If not, check 115VAC power supply wire connections from power switch. If "COMP" LED is not on after 5-min. ice purge timer terminates, replace CB. When "COMP" LED turns on, PDS energizes. If "COMP" LED is on and PDS does not energize, check for 115VAC between CB X1 relay violet or dark blue (V or DBU) wire and a neutral (W). If 115VAC is not present, confirm X1 relay black (BK) to a neutral (W). If 115VAC is present on X1 relay black (BK) and not on X1 relay violet or dark blue (V or DBU), replace CB.
- 8) **Refill "WTRIN" LED is on:** See "5) Fill "WTRIN" LED is on:" above.

Legend: **BC**–bin control (infrared sensor); **CB**–control board;
CCR–compressor control relay; **EH**–evaporator heater; **FS**–float switch;
GM–gear motor; **LFS**–lower float switch; **PDS**–pump-down solenoid valve;
UFS–upper float switch; **WV**–inlet water valve



"F-C" Control Board	
Part Number	2A8054-01

D. Bin Control Check

IMPORTANT

Make sure S1 dip switch 7 is in the "ON" position. This allows the control board to monitor the BC (infrared sensor).

- 1) Remove the front panel.
- 2) Move the power switch to the "OFF" position, then unplug the appliance from the electrical outlet.
- 3) Remove the control box cover and access CB. Confirm that S1 dip switch 1, 2, 3 are in the proper position for your application. See "III.B.2. BC (Infrared Sensor) Shutdown Delay (S1 dip switch 1, 2, 3)."
- 4) Confirm that BC is connected to CB K6 connector. Wipe down the lens with a warm, clean, damp cloth. If the bottom of the icemaker is not accessible in your application, remove the thumbscrew securing the BC housing, then remove the housing from the base. See Fig. 3.
- 5) Make sure the control switch is in the "ICE" position, then plug the icemaker into the electrical outlet.
- 6) Move the power switch to the "ON" position to start the automatic icemaking process. Check that BC green LED is on. The BC green LED confirms 20VDC from CB to BC and remains on constantly. **Diagnosis:** If the BC green LED is not on, confirm 20VDC at CB K6 pin #1 (DBU) to CB K6 pin #3 (BR). If 20VDC is present and the BC green LED is off, replace BC. If not, see step "3) BC (infrared sensor) Power Supply," under "II.C. Control Board Check."
- 7) Make sure CB "GM" LED is on. There is a delay of at least 30 sec. before CB "GM" LED turns on after power-up. After CB "GM" LED turns on, press CB "SERVICE" button to bypass the 5-min. ice purge cycle. **WARNING! Risk of electric shock. Care should be taken not to touch live terminals.**

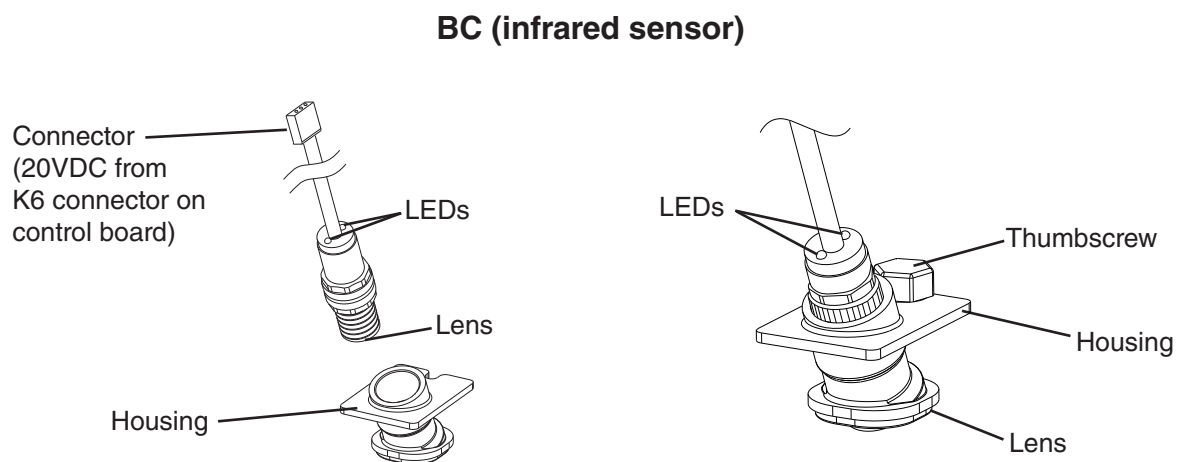

Fig. 3

8) "GM" and "COMP" LEDs are on. Use an object to cover the lens. BC yellow LED turns on (flashing or steady). BC yellow LED flashes when ice is at the outer limit of its range and turns steady as ice nears. After BC yellow LED turns on (flashing or steady), BC shutdown delay timer starts . See "III.B.2. BC (Infrared Sensor) Shutdown Delay (S1 dip switch 1, 2, 3)." PDS should de-energize immediately after the shutdown delay timer terminates. 5 min. later, GM should de-energize.

Diagnosis: If BC yellow LED is not on after covering the lens, replace BC. If the appliance remains on after BC shutdown delay timer terminates and the 5-min. ice purge timer terminates, replace CB.

- 9) Remove the object covering the lens. If you removed BC housing from the base, replace it in its correct position, and secure it with the thumbscrew.
- 10) Move the power switch to the "OFF" position, then unplug the appliance from the electrical outlet.
- 11) Replace the control box cover in its correct positions.
- 12) Plug the appliance into the electrical outlet.
- 13) Move the power switch to the "ON" position to start the automatic icemaking process.
- 14) Replace the front panel in its correct position.

Legend: **BC**—bin control (infrared sensor); **CB**—control board; **GM**—gear motor;
PDS—pump-down solenoid valve

E. Power Switch and Control Switch

The power switch and control switch are used to control the operation of this appliance. They are located on the control box.

1. Power Switch

The power switch has 2 positions, "OFF" and "ON." When the power switch is in the "OFF" position, no power is supplied to the components. When in the "ON" position, power is supplied to the control transformer and control board. The control board then supplies 5VDC to the control switch for unit operation.

2. Control Switch

The control switch has 2 positions, "ICE" and "DRAIN."

When the control switch is in the "ICE" position (open), icemaking begins.

When the control switch is in the "DRAIN" position (closed), the drain valve energizes.

a) ICE

When the control switch is in the "ICE" position, the control board reads an open circuit through the control switch contacts and starts the icemaking process.

b) DRAIN

When the control switch is in the "DRAIN" position, the control board reads a closed circuit through the control switch contacts and the drain valve energizes.

F. Float Switch Check and Cleaning

1. Float Switch Check

- 1) Remove the front panel, then move the power switch to the "OFF" position.
- 2) Move the control switch to the "DRAIN" position.
- 3) Move the power switch to the "ON" position.
- 4) Allow the water to drain from the evaporator, then move the power switch to the "OFF" position and the control switch to the "ICE" position.
- 5) Unplug the appliance from the electrical outlet.
- 6) Remove the control box cover.
- 7) Disconnect FS connector from CB K8 connector and check FS continuity. Both the UFS and LFS should be open. Check continuity between CB K8 #5 (BK) (common) and CB K8 #6 (R) (UFS). Next, check continuity between CB K8 #5 (BK) (common) and CB K8 #7 (DBU) (LFS). If both are open, continue to step 8. If either are closed, follow the steps in "II.F.2. Float Switch Cleaning." After cleaning FS, check UFS and LFS again. Replace if necessary.
- 8) Reconnect FS connector to CB K8 connector.
- 9) Plug the appliance into the electrical outlet, then move the power switch to the "ON" position and let the water reservoir fill.
- 10) Once the reservoir is full and GM starts, move the power switch to the "OFF" position.
- 11) Unplug the appliance from the electrical outlet.
- 12) Disconnect FS connector from CB K8 connector and check FS continuity. Both the UFS and LFS should be closed. Check continuity between CB K8 #5 (BK) (common) and CB K8 #6 (R) (UFS). Next, check continuity between CB K8 #5 (BK) (common) and CB K8 #7 (DBU) (LFS). If either are open, follow the steps in "II.F.2. Float Switch Cleaning." After cleaning FS, check UFS and LFS again. Replace if necessary.

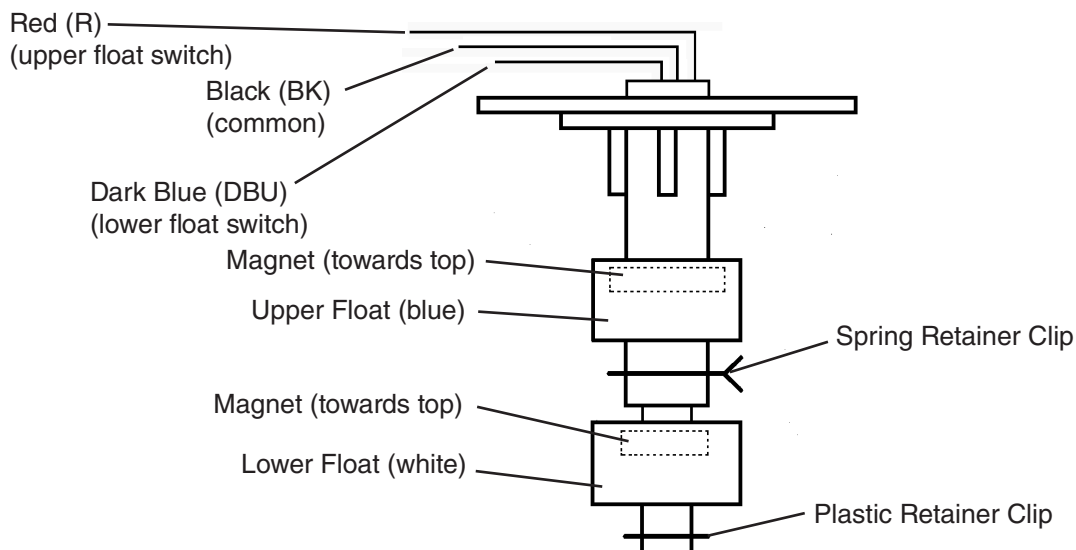

Fig. 4

- 13) Replace CB K8 connector in its correct position. Replace the control box cover in its correct position.
- 14) Plug the appliance into the electrical outlet, then move the power switch to the "ON" position to start the automatic icemaking process.
- 15) Replace the front panel in its correct position.

2. Float Switch Cleaning

Depending on local water conditions, scale may build up on FS. Scale on FS can cause inconsistent operation of UFS and LFS. In this case, both UFS and LFS should be cleaned and checked.

- 1) Remove the front panel, then move the power switch to the "OFF" position.
- 2) Unplug the appliance from the electrical outlet.
- 3) Remove FS assembly from the reservoir cover. See Fig. 5.
- 4) Wipe down FS assembly with a mixture of 1 part Hoshizaki "Scale Away" and 25 parts warm water. Rinse the assembly thoroughly with clean water.
- 5) While not necessary, the floats can be removed from the shaft during cleaning. If you remove them, note that the blue float is on top (UFS) and the white float is on bottom (LFS). The floats must be installed with the magnets inside them towards the top of the switch. See Fig. 4. Installing the floats upside down will affect the timing of FS operation.
- 6) Rinse the float switch assembly thoroughly with clean water and replace in its correct position.
- 7) Plug the appliance into the electrical outlet, then move the power switch to the "ON" position to start the automatic icemaking process.
- 8) Replace the front panel in its correct position.

Legend: **CB**—control board; **FS**—float switch; **GM**—gear motor; **LFS**—lower float switch; **UFS**—upper float switch

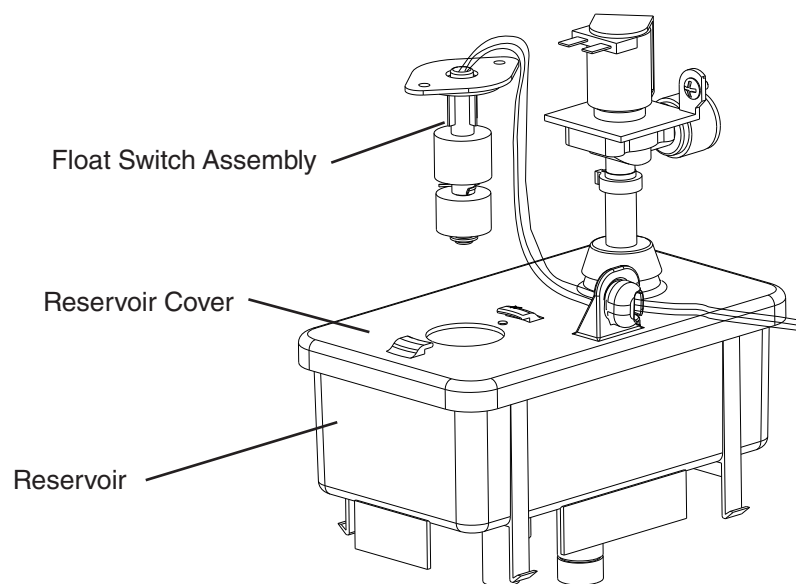

Fig. 5

G. Diagnostic Tables

Before consulting the diagnostic charts, check for correct installation, proper voltage per appliance nameplate, and adequate water supply. Check control board using the steps in "II.C. Control Board Check."

1. No Ice Production

No Ice Production - Possible Cause	
Startup	
1. Power Supply-FS	a) Unplugged, off, blown fuse, or tripped breaker.
	b) Not within specifications.
	c) Loose connection.
	d) Bad contacts.
Power Supply-SRC	a) Off, tripped breaker
	b) Not within specifications.
	c) Loose connection.
	d) Bad contacts.
2. Water Supply	a) Water supply off or improper water pressure.
	b) External water filters clogged.
3. Power Switch (Control Box)	a) "OFF" position.
	b) Bad contacts.
4. Control Transformer (115VAC/24VAC)	a) Coil winding open or shorted.
5. 1A Fuse (Control Box)	a) Blown.
6. Control Board See "II.C. Control Board Check"	a) In alarm.
	b) Defective
7. Control Switch	a) In "DRAIN" position.
	b) Bad contacts.
8. BC (infrared sensor)	a) No power, lens dirty, or defective.
	b) Control board dip switch 7 off.
Fill Cycle	
1. Control Board	a) No power to inlet water valve.
	b) No power to float switch or not reading float switch condition.
2. Inlet Water Valve	a) Screen or orifice clogged.
	b) Coil winding opened.
3. Float Switch	a) Float does not move freely.
	b) Defective.
4. Drain Valve	a) Valve seat clogged and water leaking.
5. Hoses	a) Disconnected.
Ice Purge Cycle	
1. Control Board	a) No power to gear motor.
	b) No power to compressor control relay.
2. Gear Motor	a) Blown fuse.
	b) Internal protector open.
	c) Defective.

Freeze Cycle	
1. Compressor Control Relay	a) No voltage from gear motor.
	b) Defective.
2. Control Board	a) No power to pump-down solenoid valve or not reading compressor control relay condition. Defective.
3. Pump-Down Solenoid Valve	a) Defective.
4. Control Low-Pressure Switch	a) Refrigerant pressure too low.
	b) Out of adjustment or defective.
5. Safety Low-Pressure Switch (manual reset)	a) Refrigerant pressure too low.
	b) Defective.
6. High-Pressure Switch	a) Dirty condenser.
	b) Fan(s) not operating.
	c) Ambient temperature too warm.
	d) Refrigerant overcharged.
	e) Refrigerant line or component restricted.
7. Magnetic Contactor	a) Defective.
8. Condensing Unit Fan Motor(s)	a) Defective capacitor.
	b) Fan blade binding.
	c) Defective.
9. Compressor	a) Start or run capacitor defective.
	b) Start relay defective.
	c) Defective.
10. Refrigerant Line	a) Gas leaks.
	b) Refrigerant line or component restricted.
11. Thermostatic Expansion Valve (TXV) (not adjustable)	a) Defective.
12. Evaporator	a) Dirty.
	b) Damaged or defective.
13. Headmaster (C.P.R.)	a) Not operating properly and liquid line temperature too warm.
14. Drain Valve	a) Dirty, leaking by.
	b) Defective.
15. Water System	a) Water leaks.
Refill	
1. Float Switch	a) Dirty/sticking.
	b) Defective.
2. Inlet Water Valve	a) Clogged or defective.
3. Water Supply	a) Off.
4. Control Board	a) No power to float switch or not reading float switch condition.
	b) No power to inlet water valve.

Shutdown	
1. Bin Control (infrared sensor) See "II.D. Bin Control Check."	a) Dirty lens.
	b) Defective.
	c) Control board (no power to IS).
2. Control Board	a) Control board dip switches set incorrectly.
	b) In alarm.
	c) Defective.
Drain Cycle	
1. Drain Valve	a) Screen or orifice clogged.
	b) Defective.
2. Control Board	a) Defective.

III. Controls and Adjustments

A. Control Board

- A Hoshizaki exclusive control board is employed in Hoshizaki Modular Flakers.
- All models are pre-tested and factory adjusted.
- For a control board check procedure, see "II.C. Control Board Check."

<i>NOTICE</i>
<ul style="list-style-type: none">• The control board is fragile; handle very carefully.• The control board contains integrated circuits, which are susceptible to failure due to static discharge. It is especially important to touch the metal part of the icemaker before handling or replacing the control board.• Do not touch the electronic devices on the control board or the back of the control board.• Do not change wiring and connections. Do not misconnect terminals.• Do not short out power supply to test for voltage.• Always replace the whole control board assembly if it goes bad.

1. Control Board Layout

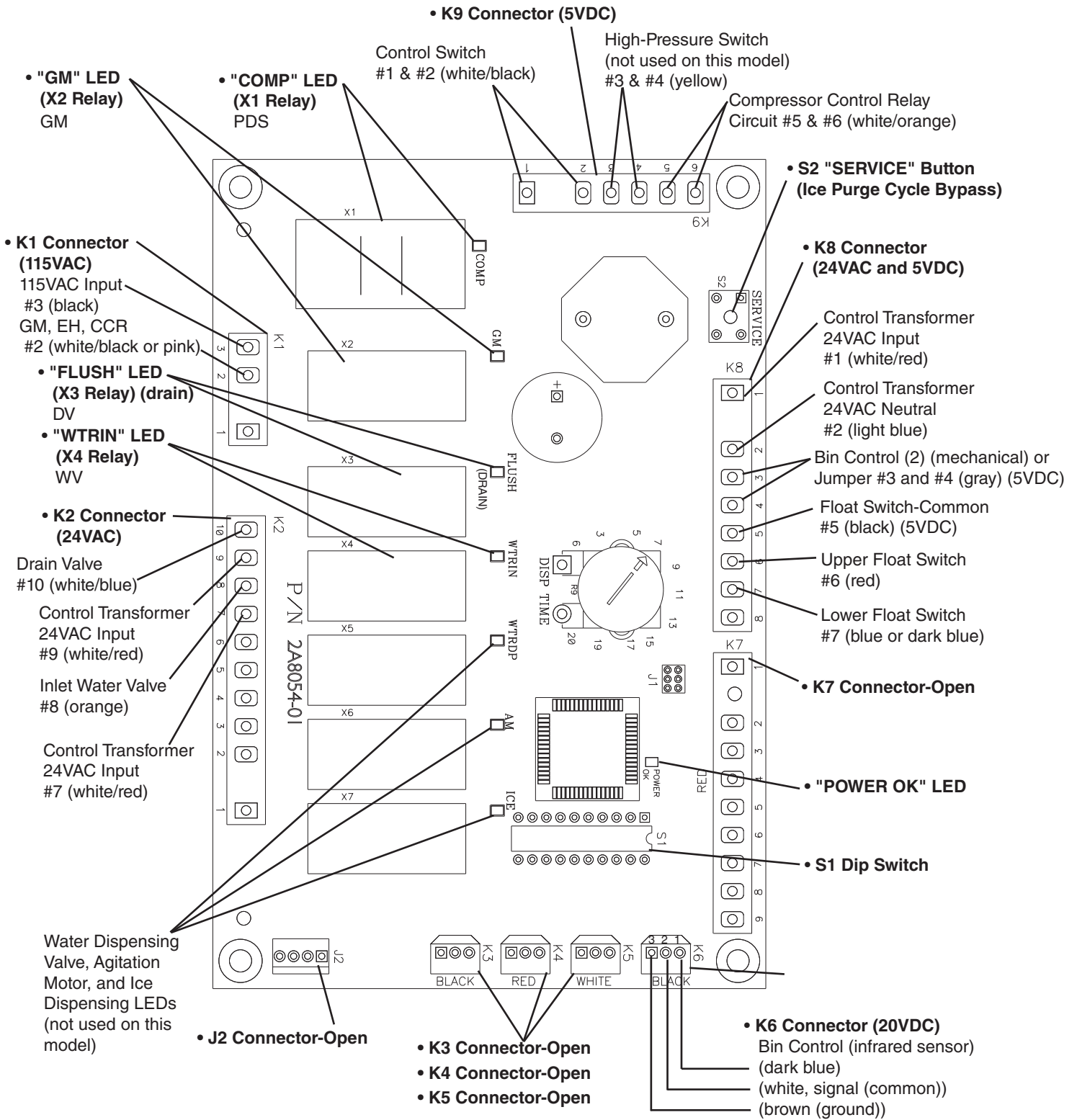

"F-C" Control Board	
Part Number	2A8054-01

2. LED Lights and Audible Alarm Safeties

At startup, CB green "POWER OK" LED turns on immediately to indicate proper control voltage and will remain on unless a control voltage problem occurs. For further details, see "II.B. Service Diagnosis."

Sequence Step	LED	Energized Components	Min.	Max.
Fill Cycle	WTRIN	WV	-	-
Ice Purge Cycle	GM	GM, EH	5 min.	5 min.
Freeze Cycle (with refill)	GM, COMP, WTRIN* (refill)	GM, EH, PDS, Comp, FMR, WV* (refill)	-	*On until UFS closes. Alarm sounds after 90 sec.
1-in-1 Drain Cycle (S1 dip switch 4 off)	FLUSH (Drain) GM, COMP (only if BC not satisfied)	DV Comp, GM, EH, PDS, FMR (only if BC not satisfied)	2 sec.	2 sec.
1-in-12 Drain Cycle (S1 dip switch 4 on)	FLUSH (Drain)	DV	10 min.	10 min.

The built-in safeties shut down the unit and have alarms as listed below.

No. of Beeps (every 5 sec.)	Type of Alarm	Reset Options
1	Low Water Safety (FT) UFS open > 90 sec. after WV energized.	Automatic reset once water supply is restored and UFS closes.
2	Control Switch In "DRAIN" position longer than 15 min..	Automatic reset once the control switch is moved to the "ICE" position.
3	High-Pressure Switch: N/A on this model.	N/A
4	High-Pressure Switch: N/A on this model.	
5	Freeze Timer (FZT) WV off > 30 min. since last WV activation.	Manual reset. Turn power off and on again.
6	Low Voltage (92VAC±5% or less)	CB green "POWER OK" LED turns off if voltage protection operates. The control voltage safeties automatically reset when voltage is corrected.
7	High Voltage (147VAC±5% or more)	
8	Gear Motor CCR contacts fail to close.	Manual reset. Turn power off and on again.

Legend: **BC**—bin control (infrared sensor); **CB**—control board; **CCR**—compressor control relay; **DV**—drain valve; **EH**—evaporator heater; **FMR**—fan motor(s)-remote; **FT**—fill timer (90-sec. low water safety timer); **FZT**—freeze timer (30-min. freeze safety timer); **GM**—gear motor; **PDS**—pump-down solenoid valve; **WV**—inlet water valve

3. Ice Purge Cycle Bypass

To speed up the diagnostic process, the 5-min. ice purge cycle may be bypassed by pressing the "SERVICE" button on the control board after the gear motor starts.

WARNING! Risk of electric shock. Care should be taken not to touch live terminals.

B. Controls and Adjustments

NOTICE

Dip switches are factory set. Failure to maintain factory settings may adversely affect performance and warranty coverage. For more information, contact your Hoshizaki Certified Service Representative.

1. Default Dip Switch Settings

The S1 dip switch settings are factory-set to the following positions:

S1 Dip Switch										
Model	S1 Dip Switch No.									
	1	2	3	4	5	6	7	8	9	10
FS-1001MLJ-C										
FS-1022MLJ-C	ON	OFF	OFF	OFF	OFF	OFF	ON	ON	OFF	OFF
FS-1500MLJ-C										

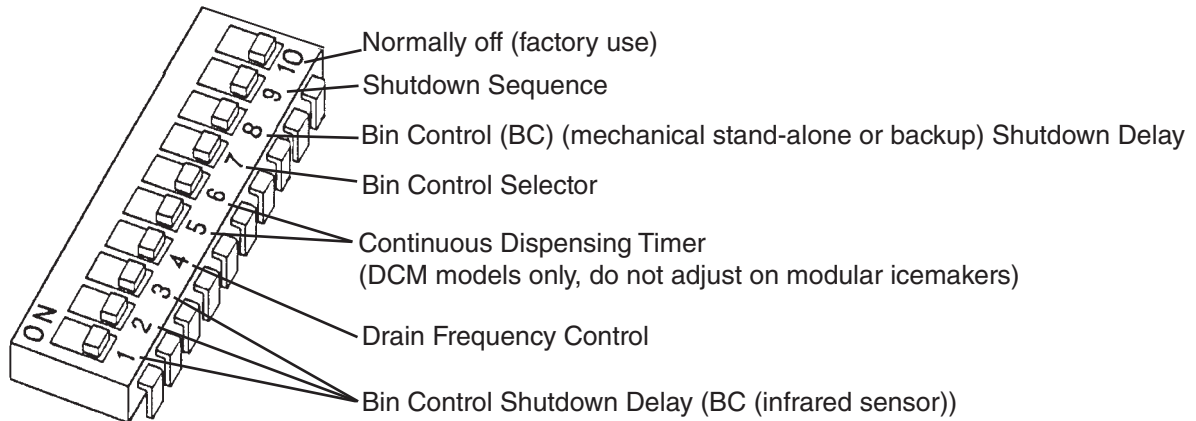

2. BC (Infrared Sensor) Shutdown Delay (S1 dip switch 1, 2, 3)

Infrared sensor shutdown delay is the delay between the infrared sensor detecting ice (infrared sensor yellow LED flashing or steady) and the start of the shutdown sequence. For dispenser unit applications, the ice level at shutoff may need to be adjusted depending on the dispenser agitation or dispense method. Increasing the shutdown delay setting allows for a higher level of ice in the bin before the icemaker shuts down. For a typical dispenser unit application, a 100-sec. shutdown delay is recommended. When used with a standard Hoshizaki storage bin, any shutdown delay setting is acceptable. **WARNING! Increasing the shutdown delay allows a higher level of ice in the dispenser unit/ice storage bin before shutdown. This could lead to icemaker movement or ice overflow.**

S1 Dip Switch Setting			Infrared Sensor Shutdown Delay
No. 1	No. 2	No. 3	
OFF	OFF	OFF	0 Seconds
ON	OFF	OFF	100 Seconds (1.6 minutes) (Factory Default)
OFF	ON	OFF	1100 Seconds (18.3 minutes)
OFF	OFF	ON	1650 Seconds (27.5 minutes)
ON	ON	OFF	2200 Seconds (36.7 minutes)
OFF	ON	ON	0 Seconds
ON	ON	ON	0 Seconds

3. Drain Frequency Control (S1 dip switch 4)

This appliance is factory set for optimum performance with the 1-in-1 drain cycle (S1 dip switch 4 in the off position). This setting allows for removal of sediment from the evaporator without interrupting the icemaking process. An optional 1-in-12 drain cycle is available.

S1 Dip Switch Setting	Drain Timer Interval	Drain Valve Open
No. 4		
OFF (1-in-1)	1 Hour	2 Seconds
ON (1-in-12)	11 Hours 45 Minutes	10 Minutes

4. Continuous Dispensing Timer (S1 dip switch 5 & 6)

DCM models only. The dispense mode switch on DCMs must be in the "CONTINUOUS" position for this setting to apply. The factory setting allows ice to be dispensed continuously as long as the dispense solenoid is activated.

S1 Dip Switch Setting		Dispense Time
No. 5	No. 6	
OFF	OFF	No Limit
ON	OFF	20 Seconds
OFF	ON	60 Seconds
ON	ON	No Limit

5. Bin Control Selector (S1 dip switch 7)

The appliance is factory set for infrared sensor bin control operation. No adjustment is required. In the factory default position (S1 dip switch 7 in the on position), the gear motor delay after the upper float switch closes is 30 sec. **WARNING! Do not place S1 dip switch 7 in the off position. This could lead to icemaker movement or ice overflow.**

S1 Dip Switch Setting	Bin Control Application	Gear Motor Delay
No. 7		
OFF	BC (mechanical stand-alone) (Standard Ice Storage Bins Only)	5 seconds
ON	BC (infrared sensor) and Mechanical Bin Control (mechanical backup)	30 seconds

6. BC (Mech. Stand-Alone or Backup (only)) Shutdown Delay (S1 dip switch 8)

Not available when S1 dip switch 7 is on. Factory set for normal operation. No adjustment is required. This appliance does not utilize a mechanical bin control.

S1 Dip Switch Setting	Mechanical Bin Control Shutdown Delay
No. 8	
OFF	0.25 Seconds
ON	6.7 Seconds

7. Shutdown Sequence (S1 Dip Switch 9)

Factory set for optimum performance. Do not adjust.

S1 Dip Switch Setting	Shutdown Sequence
No. 9	
OFF	Slow timing (90s after Mechanical Bin Control delay is satisfied, the COMP shuts down; after an additional 60s, the GM shuts down)
ON	Fast timing (after Mechanical Bin Control delay is satisfied both COMP & GM shuts down at the same time)

8. Factory Use (S1 Dip Switch 10)

Factory set for optimum performance. Do not adjust.

IV. Refrigeration Circuit and Component Service Information

⚠ WARNING

- This appliance should be diagnosed and repaired only by qualified service personnel to reduce the risk of death, electric shock, serious injury, or fire.
- **Before Servicing: FS:** Move the icemaker's power switch to the "OFF" position. Unplug the icemaker from the electrical outlet. **SRC:** Turn off the power supply to the remote condensing unit. Place the disconnect (if applicable) in the off position. Lockout/Tagout to prevent the power supply from being turned back on inadvertently.
- Do not make any alterations to the icemaker or condensing unit. Alterations could result in electric shock, injury, fire, or damage to the appliance.
- **CHOKING HAZARD:** Ensure all components, fasteners, and thumbscrews are securely in place after the appliance is serviced. Make sure that none have fallen into the dispenser unit/ice storage bin.
- Make sure all food zones in the icemaker and dispenser unit/ice storage bin are clean after service.

A. Refrigeration Circuit Service Information

⚠ WARNING

- Repairs requiring the refrigeration circuit to be opened must be performed by properly trained and EPA-certified service personnel.
- Use an electronic leak detector or soap bubbles to check for leaks. Add a trace of refrigerant to the system (if using an electronic leak detector), and then raise the pressure using nitrogen gas (140 PSIG). Do not use R-404A as a mixture with pressurized air for leak testing.

NOTICE

- Always recover the refrigerant and store it in an approved container. Do not discharge the refrigerant into the atmosphere.
- Do not leave the system open for longer than 15 min. when replacing or servicing parts. The Polyol Ester (POE) oils used in R-404A applications can absorb moisture quickly. Therefore it is important to prevent moisture from entering the system when replacing or servicing parts.
- Always install a new drier every time the sealed refrigeration system is opened. Do not replace the drier until after all other repair or replacement has been made. Install the new drier with the arrow on the drier in the direction of the refrigerant flow.
- When brazing, protect the drier by using a wet cloth to prevent the drier from overheating. Do not allow the drier to exceed 250°F (121°C).

1. Refrigerant Recovery

Using proper refrigerant practices, recover the refrigerant. Recover via the service valves. Store the refrigerant in an approved container. Do not discharge the refrigerant into the atmosphere.

2. Brazing

⚠ WARNING

- R-404A itself is not flammable at atmospheric pressure and temperatures up to 176°F (80°C).
- R-404A itself is not explosive or poisonous. However, when exposed to high temperatures (open flames), R-404A can be decomposed to form hydrofluoric acid and carbonyl fluoride both of which are hazardous.
- Do not use silver alloy or copper alloy containing arsenic.

1) Braze all fittings while purging with nitrogen gas flowing at a pressure of 3 to 4 PSIG.

NOTICE

- Always install a new drier every time the sealed refrigeration system is opened.
- Do not replace the drier until after all other repair or replacement has been made. Install the new drier with the arrow on the drier in the direction of the refrigerant flow.
- When brazing, protect the drier by using a wet cloth to prevent the drier from overheating. Do not allow the drier to exceed 250°F (121°C).

2) Use an electronic leak detector or soap bubbles to check for leaks. Add a trace of refrigerant to the system (if using an electronic leak detector), and then raise the pressure using nitrogen gas (140 PSIG). Do not use R-404A as a mixture with pressurized air for leak testing.

3. Evacuation and Recharge (R-404A)

1) Attach a vacuum pump to the system. Be sure to connect the charging hoses to both high and low-side refrigerant service valves.

IMPORTANT

The vacuum level and vacuum pump may be the same as those for current refrigerants. However, the rubber hose and gauge manifold to be used for evacuation and refrigerant charge should be exclusively for POE oils.

- 2) Turn on the vacuum pump, then open the gauge manifold valves, then open the high and low-side service valves. Never allow the oil in the vacuum pump to flow backwards.
- 3) Allow the vacuum pump to pull down to a 29.9" Hg vacuum. Evacuating period depends on pump capacity.
- 4) Close the low-side valve and high-side valve on the gauge manifold.

- 5) Disconnect the gauge manifold hose from the vacuum pump and attach it to a refrigerant service cylinder. Remember to loosen the connection and purge the air from the hose. See the rating label inside the icemaker for the required refrigerant charge. Hoshizaki recommends only virgin refrigerant or reclaimed refrigerant which meets AHRI Standard 700 (latest edition) be used.
- 6) A liquid charge is required when charging an R-404A system (to prevent fractionation). Place the service cylinder on the scales; if the service cylinder is not equipped with a dip tube, invert the service cylinder, then place it on the scales. Open the high-side valve on the gauge manifold.
- 7) Allow the system to charge with liquid until the proper charge weight is met.
- 8) If necessary, add any remaining charge to the system through the low-side.
NOTICE! To prevent compressor damage, use a throttling valve or liquid dispensing device to add the remaining liquid charge through the low-side service valve with the icemaker running.
- 9) Close the high and low-side gauge manifold valves, then disconnect the gauge manifold hoses.
- 10) Cap the service valves to prevent a possible leak.

B. Component Service Information

NOTICE

- When replacing a component listed below, see the notes to help ensure proper operation.
- When replacing evaporator assembly and water circuit components, make sure there are no water leaks after the repair is complete.
- Seal bolts must be replaced once removed because seal material is one-time use only. If new seal bolts do not have pre-applied threadlocker, apply Loctite 243 or equivalent threadlocker to seal bolt threads. Tighten to the torque values listed below.

Torque for FS-1022 and Smaller: 11.1 ft-lb/15 N·m

Torque for FS-1500 and Larger: 25.8 ft-lb/35 N·m Tighten 2 times. Allow at least 5 sec. in between each tightening.

Component	Notes
Compressor	<ul style="list-style-type: none"> • Install a new drier, start capacitor, and start relay.
Upper and Lower Bearings	<ul style="list-style-type: none"> • Inspect the upper bearing for wear. See "IV.B.1. Upper Bearing Wear Check." Replace if necessary. • When replacing the upper bearing it is advised to also change the lower bearing at the same time.
Evaporator	<ul style="list-style-type: none"> • Install a new drier. • Inspect the mechanical seal and O-ring prior to installing the new evaporator. If worn, cracked, or scratched, the mechanical seal should also be replaced.
Gear Motor	<ul style="list-style-type: none"> • Install a new gear motor capacitor.

Welded Metal Drip Pan Evaporator Assembly FS-1001MLJ-C

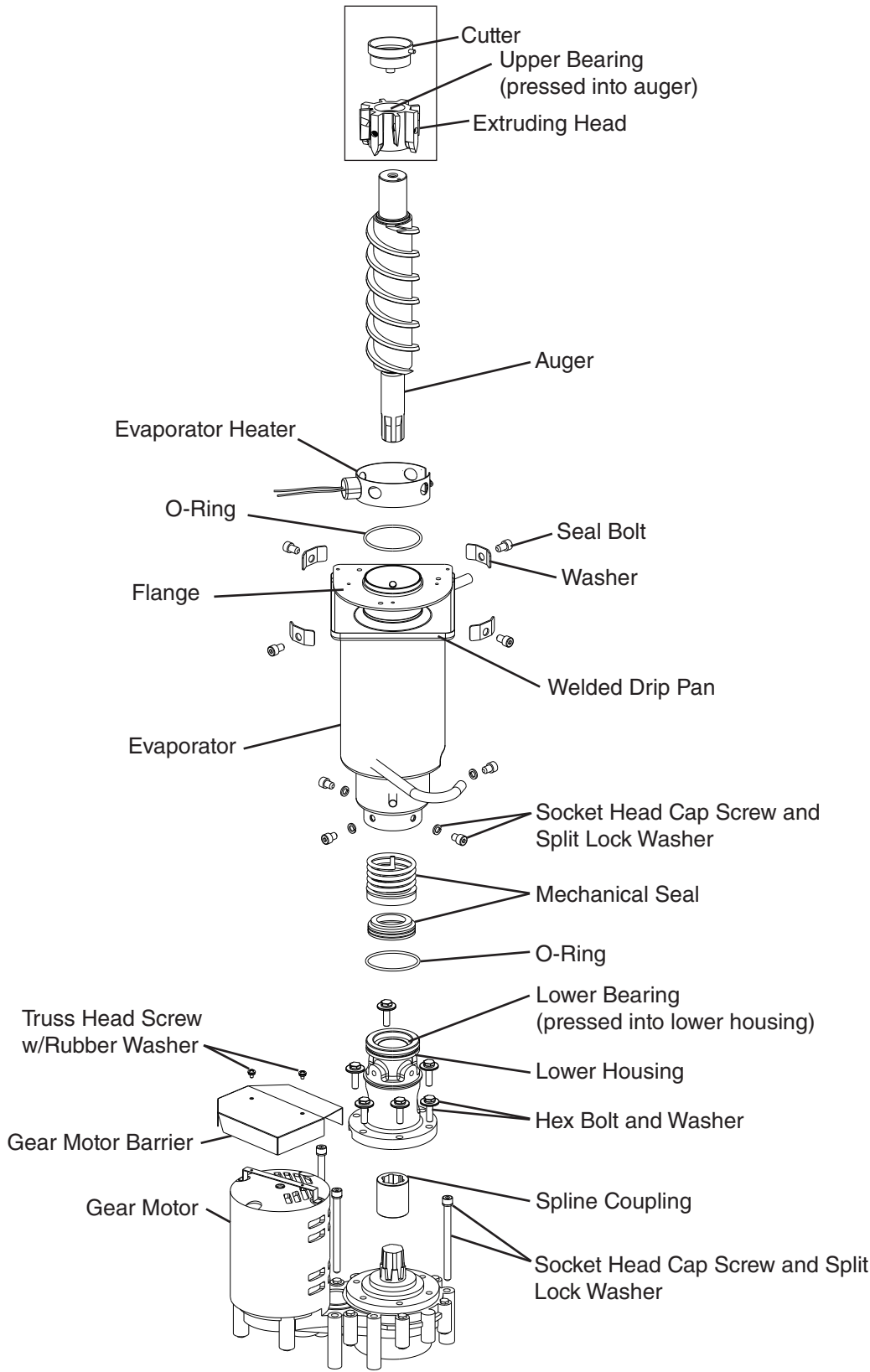
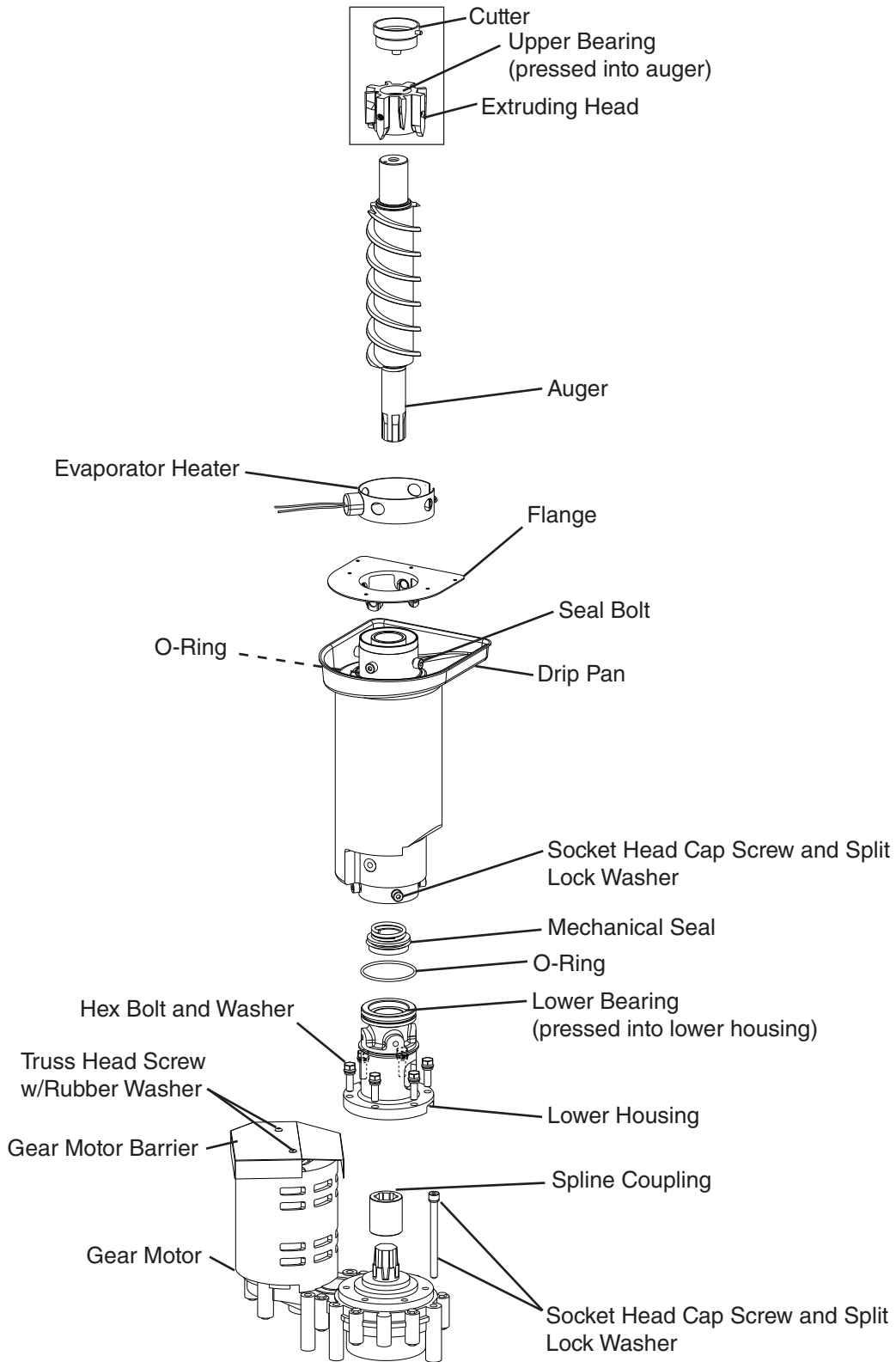

Fig. 6

Removable Rubber Drip Pan Evaporator Assembly FS-1022MLJ-C and FS-1500MLJ-C



Model Shown: FS-1022MLJ-C

Fig. 7

1. Upper Bearing Wear Check

To ensure that the bearing inside the extruding head does not exceed the wear tolerance of .02", follow the instructions below.

- 1) Remove the front panel. Move the power switch to the "OFF" position, then unplug the unit from the electrical outlet.
- 2) Remove the top and side panels.
- 3) Remove the strap connecting the spout to the chute assembly, then remove the spout.
- 4) Remove the bolt (if applicable) or cutter from the auger and lift off the cutter and washer (if applicable).

- 5) Replace the bolt in the auger (if applicable). See Fig. 8. Move the auger towards you and then try to insert a .02" round stock or pin gauge in between the back side of the auger shaft and the bearing surface. Check several locations around the auger shaft. If the gauge goes between the shaft and the bearing at any point or if the bearing is scratched or cracked, both the top bearing in the extruding head and the lower bearing in the lower housing should be replaced. Instructions for removing the extruding head and lower housing are located later in this procedure.

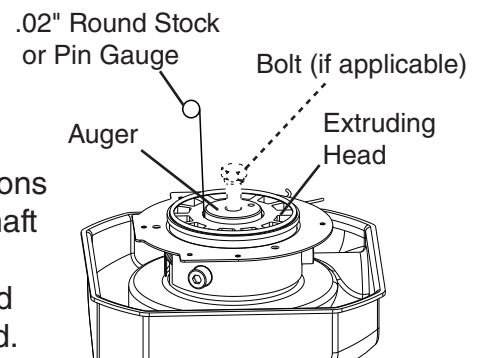

Fig. 8

Note: Replacing the bearing requires a bearing press adaptor. If one is not available, replace the whole extruding head and lower housing.

- 6) Replace the washer (if applicable), cutter, and cutter bolt (if applicable).
- 7) Replace the spout.
- 8) Replace the top and side panels in their correct positions.
- 9) Plug the unit into the electrical outlet, then move the power switch to the "ON" position.
- 10) Replace the front panel in its correct position.

2. Removal and Replacement of Cutter

- 1) Remove the front panel. Move the power switch to the "OFF" position, then unplug the unit from the electrical outlet.
- 2) Remove the top and side panels.
- 3) Remove the strap connecting the spout to the chute assembly, then remove the spout.
- 4) Remove the bolt (if applicable) or cutter and lift off the cutter.
- 5) Install the new cutter. Replace the bolt (if applicable).
- 6) Replace the spout.
- 7) Replace the top and side panels in their correct positions.
- 8) Plug the unit into the electrical outlet, then move the power switch to the "ON" position.
- 9) Replace the front panel in its correct position.

IMPORTANT! Seal Bolt Removal and Installation Instructions: Seal bolts must be replaced once removed because seal material is one-time use only. If new seal bolts do not have preapplied threadlocker, apply Loctite 243 or equivalent threadlocker to seal bolt threads.

- Torque for FS-1022 and Smaller: 11.1 ft-lb/15 N·m
- Torque for FS-1500 and Larger: 25.8 ft-lb/35 N·m Tighten 2 times. Allow at least 5 sec. in between each tightening.

3. Removal and Replacement of Extruding Head

- 1) Drain the water from the evaporator.
 - a) Remove the front panel, then move the power switch to the "OFF" position.
 - b) Move the control switch to the "DRAIN" position.
 - c) Move the power switch to the "ON" position and allow the water to drain from the evaporator.
 - d) Move the power switch to the "OFF" position, then unplug the unit from the electrical outlet.
- 2) Remove the top and side panels.
- 3) Remove the strap connecting the spout to the chute assembly, then remove the spout.
- 4) Remove the cutter bolt (if applicable) or cutter and lift off the cutter and washer (if applicable).
- 5) Remove the seal bolts and lift off the extruding head.
- 6) Place the new extruding head in place and tighten down with new seal bolts.
See "Seal Bolt Removal and Installation Instructions" above.
- 7) Replace the washer (if applicable), cutter, cutter bolt (if applicable), and spout.
- 8) Replace the top and side panels in their correct positions.
- 9) Move the control switch to the "ICE" position.
- 10) Plug the unit into the electrical outlet, then move the power switch to the "ON" position.
- 11) Replace the front panel in its correct position.

4. Removal and Replacement of Auger

- 1) Drain the water from the evaporator.
 - a) Remove the front panel, then move the power switch to the "OFF" position.
 - b) Move the control switch to the "DRAIN" position.
 - c) Move the power switch to the "ON" position and allow the water to drain from the evaporator.
 - d) Move the power switch to the "OFF" position, then turn off the power supply.
- 2) Remove the top and side panels.
- 3) Remove the strap connecting the spout to the chute assembly, then remove the spout.
- 4) Remove the extruding head seal bolts. Using the cutter, lift out the auger assembly.
- 5) Remove the cutter bolt (if applicable), cutter, washer (if applicable), and dowel pin (if applicable). Remove the extruding head from the auger and place on the new auger.
- 6) Install the new auger.

- 7) Replace the removed parts in the reverse order of which they were removed.
Note: Be sure to use new seal bolts. See "Seal Bolt Removal and Installation Instructions" above.
- 8) Replace the top and side panels in their correct positions.
- 9) Move the control switch to the "ICE" position.
- 10) Plug the unit into the electrical outlet, then move the power switch to the "ON" position to start the automatic icemaking process.
- 11) Replace the front panel in its correct position.

5. Removal and Replacement of Evaporator

NOTICE

- Always install a new drier every time the sealed refrigeration system is opened.
- Do not replace the drier until after all other repair or replacement has been made. Install the new drier with the arrow on the drier in the direction of the refrigerant flow.
- When brazing, protect the drier by using a wet cloth to prevent the drier from overheating. Do not allow the drier to exceed 250°F (121°C).

- 1) Drain the water from the evaporator.
 - a) Remove the front panel, then move the power switch to the "OFF" position.
 - b) Move the control switch to the "DRAIN" position.
 - c) Move the power switch to the "ON" position and allow the water to drain from the evaporator.
 - d) Move the power switch to the "OFF" position, then turn off the power supply.
- 2) Remove the top and side panels.
- 3) Recover the refrigerant and store it in an approved container.
- 4) Remove the strap connecting the spout to the chute assembly, then remove the spout.
- 5) Disconnect the water hoses.
- 6) Remove the extruding head seal bolts. Using the cutter, lift out the auger assembly.
- 7) Remove the insulation and the expansion valve bulb on the suction line.
- 8) Disconnect the inlet and outlet tubing.
- 9) Remove the socket head cap screws and split lock washers securing the evaporator to the lower housing.
- 10) Lift off the evaporator.
- 11) Inspect the mechanical seal and O-ring prior to installing the new evaporator. The mechanical seal consists of two parts. One moves along with the auger, and the other is fixed on the lower housing. If the contact surfaces of these two parts are worn, cracked, or scratched, the mechanical seal may cause water leaks and should be replaced. Instructions for removing the mechanical seal and lower housing are located later in this procedure.

- 12) Make sure the lower mechanical seal is in place, then place the evaporator in position. Secure the evaporator to the lower housing using the socket head cap screws and split lock washers.
- 13) Remove the drier, then place the new drier in position.
- 14) Braze all fittings while purging with nitrogen gas flowing at a pressure of 3 to 4 PSIG.
- 15) Use an electronic leak detector or soap bubbles to check for leaks. Add a trace of refrigerant to the system (if using an electronic leak detector), and then raise the pressure using nitrogen gas (140 PSIG). Do Not use R-404A as a mixture with pressurized air for leak testing.
- 16) Evacuate the system, and charge it with refrigerant. See the rating label inside the icemaker for the required refrigerant charge. Hoshizaki recommends only virgin refrigerant or reclaimed refrigerant which meets ARI Standard 700 (latest edition) be used.
- 17) Replace the removed parts in the reverse order of which they were removed.
Note: Be sure to use new seal bolts. See "Seal Bolt Removal and Installation Instructions" earlier in this section.
- 18) Replace the top and side panels in their correct positions.
- 19) Move the control switch to the "ICE" position.
- 20) Plug the unit into the electrical outlet, then move the power switch to the "ON" position to start the automatic icemaking process.
- 21) Replace the front panel in its correct position.

6. Removal and Replacement of Mechanical Seal and Lower Housing

6a. Mechanical Seal

- 1) Drain the water from the evaporator.
 - a) Remove the front panel, then move the power switch to the "OFF" position.
 - b) Move the control switch to the "DRAIN" position.
 - c) Move the power switch to the "ON" position and allow the water to drain from the evaporator.
 - d) Move the power switch to the "OFF" position, then turn off the power supply.
- 2) Remove the top and side panels.
- 3) Remove the strap connecting the spout to the chute assembly, then remove the spout.
- 4) Remove the extruding head seal bolts. Using the cutter, lift out the auger assembly.
- 5) The mechanical seal consists of two parts. One moves along with the auger, and the other is fixed on the lower housing. If the contact surfaces of these two parts are worn, cracked, or scratched, the mechanical seal may cause water leaks and should be replaced.
- 6) Remove the socket head cap screws and split lock washers securing the evaporator to the lower housing.
- 7) Raise the evaporator up to access the lower housing.

- 8) Remove the O-ring and mechanical seal from the housing. If only replacing the mechanical seal, proceed to step 15. **NOTICE! To help prevent water leaks, be careful not to damage the surfaces of the O-ring or mechanical seal.**

NOTICE

To help prevent water leaks, be careful not to damage the surfaces of the O-ring or mechanical seal.

6b. Lower Housing

- 9) Remove the hex bolts w/washers securing the lower housing to the gear motor and remove the lower housing from the gear motor. If inspection of the upper bearing inside the extruding head (see "IV.B.1. Upper Bearing Wear Check") indicates that it is out of tolerance, replace both it and the bearing inside the lower housing.
Note: Replacing the bearing requires a bearing press adaptor. If one is not available, replace the whole extruding head and lower housing.
- 10) Mount the lower housing on the gear motor.
- 11) Install the O-ring and lower part of the mechanical seal on the lower housing.
- 12) Make sure the lower mechanical seal is in place, then place the evaporator in position. Secure the evaporator to the lower housing using the socket head cap screws and split lock washers.
- 13) Install the auger assembly with the upper part of the mechanical seal attached.
- 14) Replace the removed parts in the reverse order of which they were removed.
Note: Be sure to use new seal bolts. See "Seal Bolt Removal and Installation Instructions" earlier in this section.
- 15) Replace the top and side panels in their correct positions.
- 16) Move the control switch to the "ICE" position.
- 17) Plug the unit into the electrical outlet, then move the power switch to the "ON" position to start the automatic icemaking process.
- 18) Replace the front panel in its correct position.

7. Removal and Replacement of Gear Motor

- 1) Drain the water from the evaporator.
a) Remove the front panel, then move the power switch to the "OFF" position.
b) Move the control switch to the "DRAIN" position.
c) Move the power switch to the "ON" position and allow the water to drain from the evaporator.
d) Move the power switch to the "OFF" position, then turn off the power supply.
- 2) Remove the top and side panels.
- 3) Remove the strap connecting the spout to the chute assembly, then remove the spout.
- 4) Remove the hex head bolts and washers securing the lower housing to the gear motor. Lift the evaporator up slightly.
- 5) Remove the socket head cap screws with split lock washers securing the gear motor.

- 6) Disconnect the gear motor wiring, then remove the gear motor.
- 7) Remove the gear motor bracket and spline coupling from the old gear motor and place on the new gear motor.
- 8) Install the new gear motor and reconnect the electrical wires.
- 9) Replace the removed parts in the reverse order of which they were removed.
- 10) Replace the top and side panels in their correct positions.
- 11) Move the control switch to the "ICE" position.
- 12) Plug the unit into the electrical outlet, then move the power switch to the "ON" position to start the automatic icemaking process.
- 13) Replace the front panel in its correct position.

V. Maintenance

The appliance must be maintained in accordance with the instruction manual and labels provided. Consult with your local Hoshizaki Certified Service Representative about maintenance service.

WARNING

- Only qualified service technicians should service the appliance.
- To reduce the risk of electric shock, do not touch the icemaker power switch or control switch with damp hands.
- **Before Servicing: FS:** Move the icemaker's power switch to the "OFF" position. Unplug the icemaker from the electrical outlet. **SRC:** Turn off the power supply to the remote condensing unit. Place the disconnect (if applicable) in the off position. Lockout/Tagout to prevent the power supply from being turned back on inadvertently.
- **CHOKING HAZARD:** Ensure all components, fasteners, and thumbscrews are securely in place after any maintenance is done to the appliance. Make sure that none have fallen into the dispenser unit/ice storage bin.

A. Maintenance Schedule

The maintenance schedule below is a guideline. More frequent maintenance may be required depending on water quality, the appliance's environment, and local sanitation regulations.

Maintenance Schedule		
Frequency	Area	Task
Daily	Scoop	Clean the ice scoop using a neutral cleaner. Rinse thoroughly after cleaning.
Monthly	External Water Filters	Check for proper pressure and change if necessary.
	Icemaker Exterior	Wipe down with a clean, soft cloth. Use a damp cloth containing a neutral cleaner to wipe off oil or dirt build up. Clean any chlorine staining (rust colored spots) using a non-abrasive cleanser.
	Infrared Sensor Lens; Underside of Icemaker and Top Kits; Bin Door and Snout	Wipe down with a clean cloth and warm water.
Every 6 Months	Icemaker and Dispenser Unit/Ice Storage Bin	Clean and sanitize per the cleaning and sanitizing instructions provided in the instruction manual or on maintenance label.
	Evaporator Condensate Drain Pan and Gear Motor Drain Pan	Wipe down with a clean cloth and warm water. Slowly pour one cup of sanitizing solution (prepare as outlined in the sanitizing instructions provided in the instruction manual) into the evaporator condensate drain pan and then slowly pour one cup into the gear motor drain pan. Be careful not to overflow the pans. Repeat with a cup of clean water to rinse.
	Icemaker and Dispenser Unit/Ice Storage Bin Drains	Check to make sure they are clear.
	Extruding Head Seal Bolts	Inspect for leakage around seal bolts. Tighten (see torque values below) or replace as necessary. Seal bolts must be replaced once removed because seal material is one-time use only. If new seal bolts do not have preapplied threadlocker, apply Loctite 243 or equivalent threadlocker to seal bolt threads. Do not apply Loctite 243 threadlocker over preapplied threadlocker. <ul style="list-style-type: none"> • <i>Torque for FS-1022 and Smaller:</i> 11.1 ft-lb/15 N·m • <i>Torque for FS-1500 and Larger:</i> 25.8 ft-lb/35 N·m Tighten 2 times. Allow at least 5 sec. in between each tightening.
Yearly	Inlet Water Valve and Drain Valve	Close the water supply line shut-off valve and drain the water system. Clean the inlet water valve screen and clean and inspect the drain valve.
	Water Hoses	Inspect the water hoses and clean/replace if necessary.
	Condenser	Inspect. Clean if necessary by using a brush or vacuum cleaner.
	Icemaker	Inspect for oil spots, loose components, fasteners, and wires.
	Upper Bearing (extruding head)	Check for wear using .02" round stock or pin gauge. Replace both upper bearing and lower bearing if wear exceeds factory recommendations.
After 3 Years, then Yearly	Upper Bearing (extruding head); Lower Bearing and O-Ring (lower housing); Mechanical Seal; Evaporator Cylinder; Auger	Inspect. Replace both upper bearing and lower bearing if wear exceeds factory recommendations. Replace the mechanical seal if the seal's contact surfaces are worn, cracked, or scratched.

VI. Disposal

The appliance contains refrigerant and must be disposed of in accordance with applicable national, state, and local codes and regulations. Refrigerant must be recovered by properly certified service personnel.

VII. Technical Information

A. Specification and Performance Data Sheets

1. FS-1001MLJ-C with SRC-10J

Specification Sheet

AC SUPPLY VOLTAGE	115/60/1 (Corded)	
AMPERES	3.0 FLA	
MAXIMUM FUSE SIZE	15 A	
MAXIMUM CIRCUIT AMPACITY	15 A	
ELECTRIC & WATER CONSUMPTION	90/70°F	70/50°F
ELECTRIC W (kWH/100 lbs.)	5167(5.07)	4293(4.29)
POTABLE WATER	86(12.0)	102(12.0)
ICE HARDNESS	Approx. 85.8%, Ice (32/21 (90/70), Conductivity 200 µs/cm)	
BIN CONTROL SYSTEM	Photoelectric Sensor	
REFRIGERANT CHARGE	TOTAL R404A, 16 lb. 1.5 oz. (7300g) ICEMAKER, 0 lb. 3.5 oz. (100g) CONDENSER, 15 lb. 14 oz. (7200g)	

Performance Data Sheet

APPROXIMATE ICE PRODUCTION PER 24 HR. lbs./day (kg/day)	Ambient Temp. °F (°C)	Water Temp. °F (°C)		
		50 (10)	70 (21)	90 (32)
	70 (21)	* 851 (386)	844 (383)	818 (371)
	80 (26)	793 (360)	769 (349)	745 (338)
	90 (32)	722 (328)*	720 (327)	679 (308)
	100 (38)	658 (298)	638 (289)	* 597 (271)
APPROXIMATE ELECTRIC CONSUMPTION watts	70 (21)	* 4293 --	4418 --	4543 --
	80 (26)	4668 --	4792 --	4917 --
	90 (32)	5042 --	* 5167 --	5496 --
	100 (38)	5825 --	6154 --	* 6483 --
APPROXIMATE WATER CONSUMPTION PER 24 HR. (TOTAL) gal. / day (l/day)	70 (21)	* 102 (387)	101 (383)	98 (372)
	80 (26)	95 (360)	92 (349)	89 (339)
	90 (32)	87 (328)*	86 (327)	81 (308)
	100 (38)	79 (299)	77 (290)	* 72 (271)
EVAPORATOR OUTLET TEMP. °F (°C)	70 (21)	* 13 ((-11))	14 ((-10))	14 ((-10))
	80 (26)	15 ((-10))	15 ((-9))	16 ((-9))
	90 (32)	16 ((-9))*	17 ((-9))	17 ((-8))
	100 (38)	17 ((-8))	17 ((-8))	* 17 ((-8))
HEAD PRESSURE PSIG (kg/cm ² G)	70 (21)	* 205 (14.4)	210 (14.7)	214 (15.0)
	80 (26)	218 (15.4)	223 (15.7)	227 (16.0)
	90 (32)	231 (16.3)*	236 (16.6)	247 (17.4)
	100 (38)	259 (18.2)	270 (19.0)	* 281 (19.8)
SUCTION PRESSURE PSIG (kg/cm ² G)	70 (21)	* 30 (2.1)	30 (2.1)	30 (2.1)
	80 (26)	30 (2.1)	31 (2.1)	31 (2.2)
	90 (32)	31 (2.2)*	31 (2.2)	32 (2.2)
	100 (38)	33 (2.3)	33 (2.3)	* 34 (2.4)
HEAT OF REJECTION FROM CONDENSER	9,400 BTU/h (AT 90°F / WT 70°F)			
HEAT OF REJECTION FROM COMPRESSOR	1,600 BTU/h (AT 90°F / WT 70°F)			

2. FS-1022MLJ-C with SRC-10J

Specification Sheet

AC SUPPLY VOLTAGE	115/60/1	
AMPERAGE	3.1 A	
MINIMUM CIRCUIT AMPACITY	15 A	
MAXIMUM FUSE SIZE	15 A	
ELECTRIC & WATER CONSUMPTION	90/70°F	70/50°F
ELECTRIC W (kWH/100 lbs.)	1532(5.10)	1445(3.93)
POTABLE WATER	88(12.0)	107(12.0)
ICE HARDNESS	Approx. 91.0%, Ice (32/21 (90/70), Conductivity 200 µs/cm)	
BIN CONTROL SYSTEM	Photoelectric Sensor	
REFRIGERANT CHARGE	R404A, 16 lb. 1 oz. (7300g) Ice Maker: 0 lb. 3.5 oz. (100g) CONDENSOR: 15 lb. 14 oz. (7200g)	

Performance Data Sheet

APPROXIMATE ICE PRODUCTION PER 24 HR. lbs./day (kg/day)	Ambient Temp. °F (°C)	Water Temp. °F (°C)		
		50 (10)	70 (21)	90 (32)
	70 (21)	* 889 (403)	878 (398)	848 (385)
	80 (26)	819 (371)	790 (359)	763 (346)
	90 (32)	737 (334)	* 730 (331)	687 (312)
	100 (38)	663 (301)	641 (291)	* 598 (271)
APPROXIMATE ELECTRIC CONSUMPTION watts	70 (21)	* 1445 --	1457 --	1470 --
	80 (26)	1482 --	1494 --	1507 --
	90 (32)	1519 --	* 1532 --	1541 --
	100 (38)	1550 --	1559 --	* 1568 --
APPROXIMATE WATER CONSUMPTION PER 24 HR. (TOTAL) gal. / day (l/day)	70 (21)	* 107 (404)	105 (399)	102 (385)
	80 (26)	98 (372)	95 (359)	92 (347)
	90 (32)	88 (335)	* 88 (332)	82 (312)
	100 (38)	80 (302)	77 (291)	* 72 (272)
EVAPORATOR OUTLET TEMP. °F (°C)	70 (21)	* 8 ((-13))	9 ((-13))	9 ((-13))
	80 (26)	9 ((-13))	9 ((-13))	10 ((-12))
	90 (32)	10 ((-12))	* 10 ((-12))	11 ((-12))
	100 (38)	12 ((-11))	13 ((-10))	* 14 ((-10))
HEAD PRESSURE PSIG (kg/cm ² G)	70 (21)	* 193 (13.6)	203 (14.3)	214 (15.0)
	80 (26)	224 (15.7)	234 (16.5)	245 (17.2)
	90 (32)	255 (17.9)	* 265 (18.7)	278 (19.5)
	100 (38)	291 (20.4)	304 (21.3)	* 316 (22.2)
SUCTION PRESSURE PSIG (kg/cm ² G)	70 (21)	* 29 (2.0)	29 (2.0)	30 (2.1)
	80 (26)	30 (2.1)	31 (2.2)	31 (2.2)
	90 (32)	32 (2.2)	* 32 (2.3)	33 (2.3)
	100 (38)	33 (2.3)	34 (2.4)	* 35 (2.4)
CONDENSER VOLUME	133 in ³			
HEAT OF REJECTION FROM CONDENSER	9,700 BTU/h (AT 90°F / WT 70°F)			
HEAT OF REJECTION FROM COMPRESSOR	1,500 BTU/h (AT 90°F / WT 70°F)			

3. FS-1500MLJ-C with SRC-14J

Specification Sheet

AC SUPPLY VOLTAGE	115/60/1	
AMPERAGE	3.6 A	
MINIMUM CIRCUIT AMPACITY	15 A	
MAXIMUM FUSE SIZE	15 A	
ELECTRIC & WATER CONSUMPTION	90/70°F	70/50°F
ELECTRIC W (kWH/100 lbs.)	2196(4.75)	2128(3.67)
POTABLE WATER	135(12.0)	107(12.0)
ICE HARDNESS	Approx. 90.0%, Ice (32/21 (90/70), Conductivity 200 µs/cm)	
BIN CONTROL SYSTEM	Photoelectric Sensor	
REFRIGERANT CHARGE	R404A, 11 lb. 0 oz. (5000g) Ice Maker: 0 lb. 3.5 oz. (100g) Cond. Unit: 10 lb. 12.8 oz. (4900g)	

Performance Sheet

APPROXIMATE ICE PRODUCTION PER 24 HR.	Ambient Temp. °F (°C)	Water Temp. °F (°C)		
		50 (10)	70 (21)	90 (32)
lbs./day (kg/day)	70 (21)	* 1386 (629)	1366 (620)	1318 (598)
	80 (26)	1271 (576)	1225 (556)	1181 (536)
	90 (32)	1139 (517)	* 1125 (510)	1059 (480)
	100 (38)	1021 (463)	985 (447)	* 919 (417)
APPROXIMATE ELECTRIC CONSUMPTION	70 (21)	* 2128 --	2138 --	2148 --
	80 (26)	2157 --	2167 --	2177 --
	90 (32)	2187 --	* 2196 --	2202 --
	100 (38)	2207 --	2212 --	* 2217 --
APPROXIMATE WATER CONSUMPTION PER 24 HR. (TOTAL) gal. / day (l/day)	70 (21)	* 166 (630)	164 (621)	158 (599)
	80 (26)	153 (577)	147 (557)	142 (537)
	90 (32)	137 (518)	* 135 (511)	127 (481)
	100 (38)	123 (464)	118 (448)	* 110 (418)
EVAPORATOR OUTLET TEMP. °F (°C)	70 (21)	* 18 ((-8))	19 ((-7))	19 ((-7))
	80 (26)	19 ((-7))	20 ((-7))	20 ((-7))
	90 (32)	20 ((-6))	* 21 ((-6))	21 ((-6))
	100 (38)	21 ((-6))	22 ((-6))	* 22 ((-6))
HEAD PRESSURE	70 (21)	* 198 (13.9)	203 (14.3)	209 (14.7)
	80 (26)	214 (15.1)	220 (15.4)	225 (15.8)
	90 (32)	230 (16.2)	* 236 (16.6)	244 (17.2)
	100 (38)	253 (17.8)	262 (18.4)	* 271 (19.0)
SUCTION PRESSURE PSIG (kg/cm ² G)	70 (21)	* 33 (2.3)	33 (2.3)	34 (2.4)
	80 (26)	34 (2.4)	34 (2.4)	35 (2.5)
	90 (32)	35 (2.5)	* 36 (2.5)	36 (2.6)
	100 (38)	37 (2.6)	38 (2.6)	* 38 (2.7)
CONDENSER VOLUME	133 in ³			
HEAT OF REJECTION FROM CONDENSER	15,300 BTU/h (AT 90°F / WT 70°F)			
HEAT OF REJECTION FROM COMPRESSOR	2,100 BTU/h (AT 90°F / WT 70°F)			

B. Wiring Diagrams

1. FS-1001MLJ-C and FS-1022MLJ-C

DIP SWITCH SI	No. 1	No. 2	No. 3	No. 4	No. 5	No. 6	No. 7	No. 8	No. 9	No. 10
FS-1001MLJ-C	ON	OFF	OFF	OFF	OFF	OFF	ON	ON	OFF	OFF
FS-1022MLJ-C	ON	OFF	OFF	OFF	OFF	OFF	ON	ON	OFF	OFF

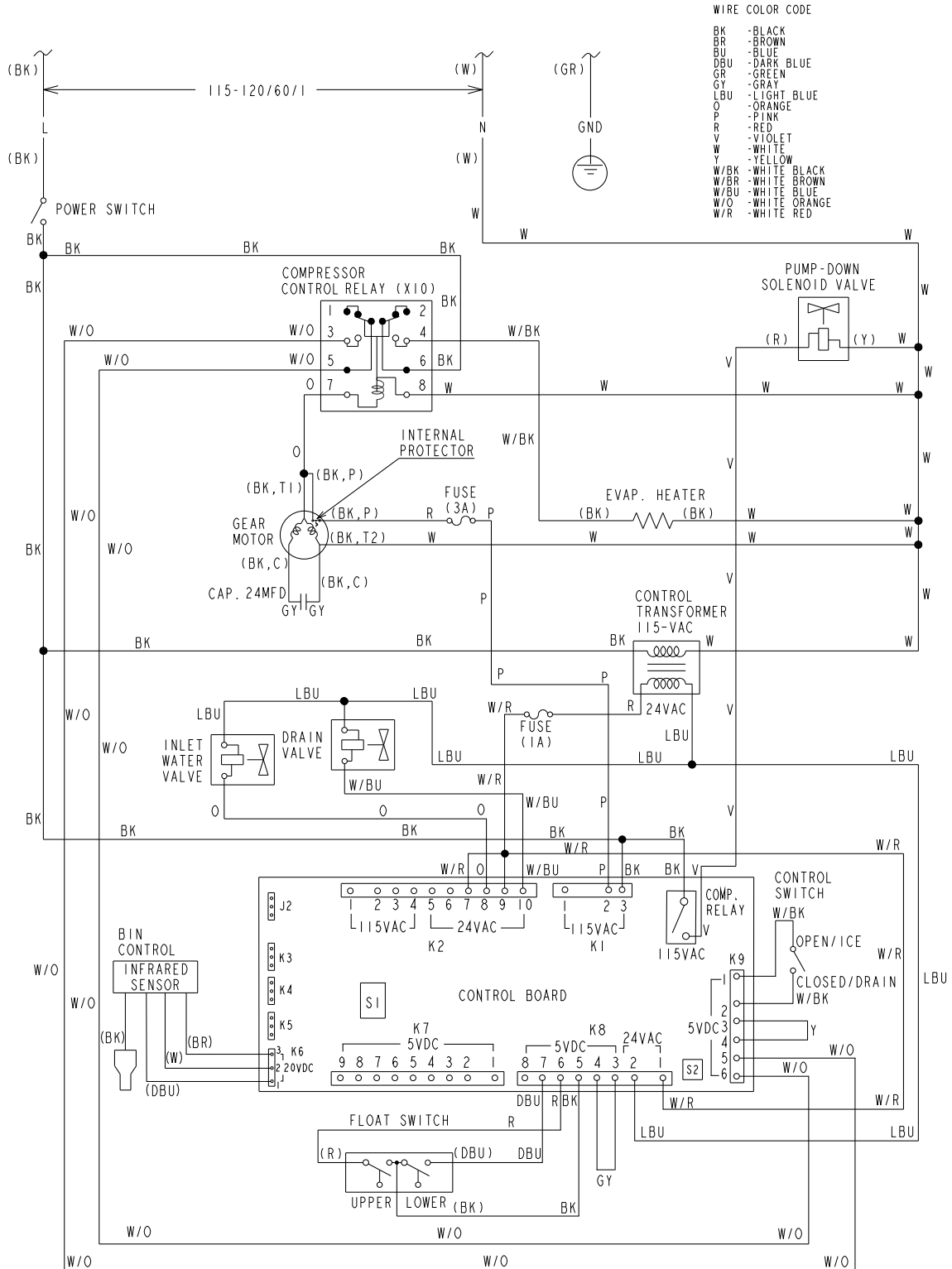

2. FS-1500MLJ-C

DIP SWITCH S1	No. 1	No. 2	No. 3	No. 4	No. 5	No. 6	No. 7	No. 8	No. 9	No. 10
FS-1500MLJ-C	ON	OFF	OFF	OFF	OFF	OFF	ON	ON	OFF	OFF

WIRE COLOR CODE

BK	-BLACK
BR	-BROWN
BU	-BLUE
DBU	-DARK BLUE
GR	-GREEN
GY	-GRAY
LBU	-LIGHT BLUE
O	-ORANGE
P	-PINK
R	-RED
V	-VIOLET
W	-WHITE
Y	-YELLOW
W/BK	-WHITE BLACK
W/BR	-WHITE BROWN
W/BU	-WHITE BLUE
W/O	-WHITE ORANGE
W/R	-WHITE RED

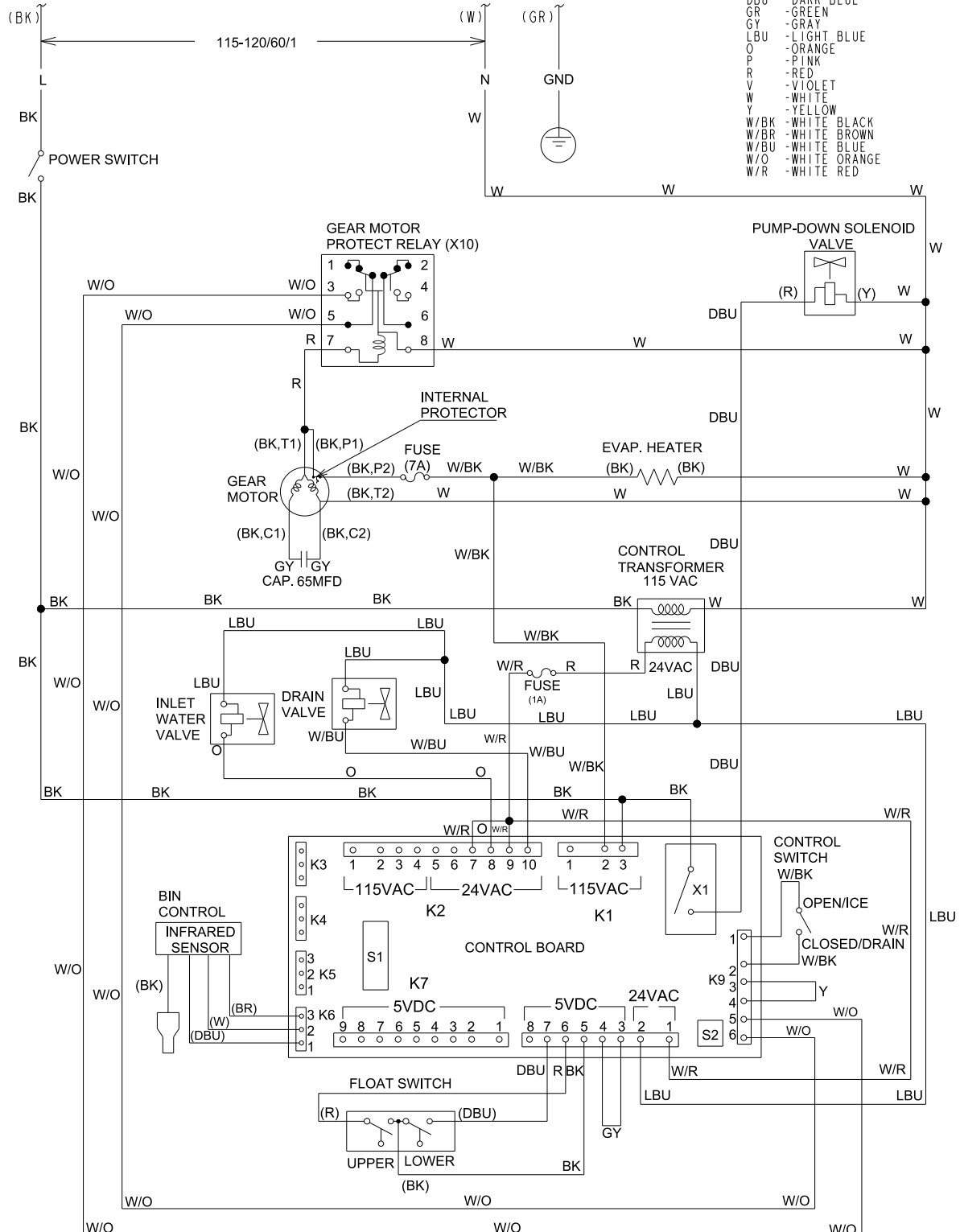

3. SRC-10J Condensing Unit

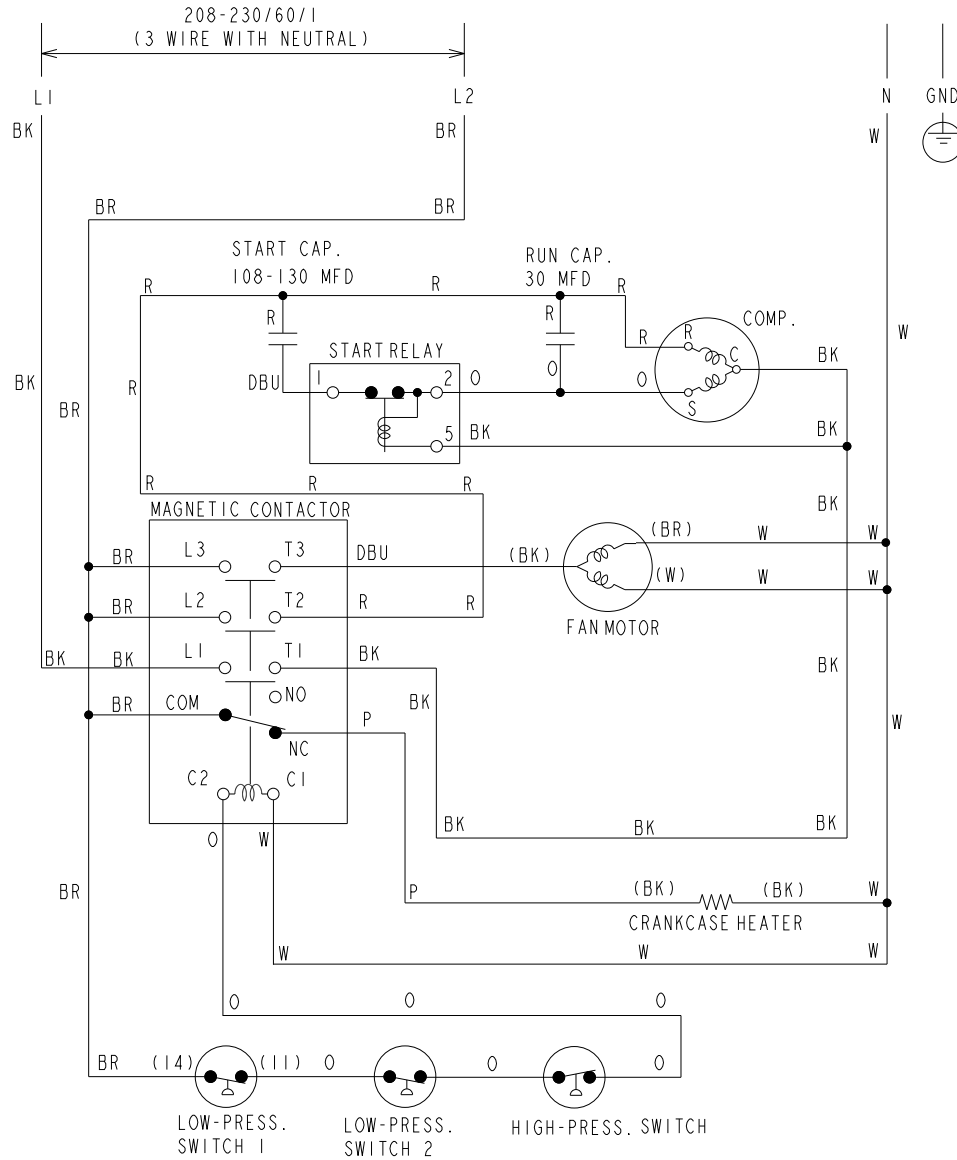

CCH	CRANKCASE HEATER
COMP	COMPRESSOR
FM	FAN MOTOR
HPS	HIGH-PRESSURE SWITCH
LPS1	LOW-PRESSURE SWITCH 1
LPS2	LOW-PRESSURE SWITCH 2
MC	MAGNETIC CONTACTOR
RC	RUN CAPACITOR
SC	START CAPACITOR
SR	START RELAY

WIRE COLOR CODE
BK -BLACK
BR -BROWN
BU -BLUE
DBU -DARK BLUE
GR -GREEN
GY -GRAY
LBU -LIGHT BLUE
O -ORANGE
P -PINK
R -RED
V -VIOLET
W -WHITE
Y -YELLOW
W/BK -WHITE BLACK
W/BR -WHITE BROWN
W/BU -WHITE BLUE
W/O -WHITE ORANGE
W/R -WHITE RED

* Control Low-Pressure Switch	
Cut-in	29± _{0.5} PSIG
Differential	20± _{0.5} ¹⁰ PSIG
Cut-out	9 PSIG

** Safety Low-Pressure Switch (Manual Reset)	
Cut-out	3±2.5 PSIG
Differential	6 PSIG

*** High-Pressure Switch	
Cut-out	384± ₀ ²² PSIG
Cut-in	284±22 PSIG

4. SRC-14J Condensing Unit

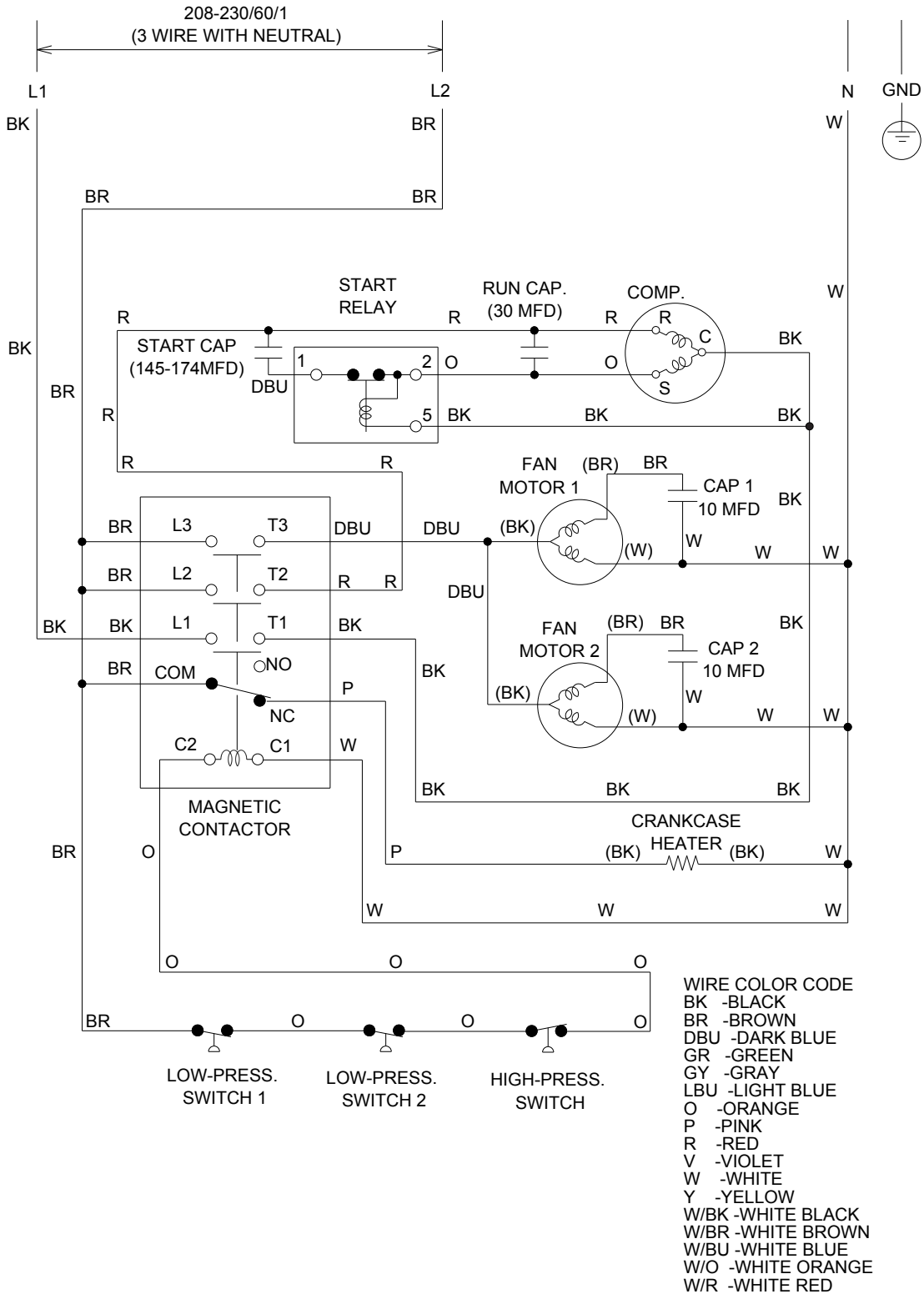

* Control Low-Pressure Switch	
Cut-in	$29 \pm_{0.5}^0$ PSIG
Differential	$20 \pm_{0.5}^{1.0}$ PSIG
Cut-out	9 PSIG

** Safety Low-Pressure Switch (Manual Reset)	
Cut-out	3 ± 2.5 PSIG
Differential	6 PSIG

*** High-Pressure Switch	
Cut-out	$384 \pm_{0}^{22}$ PSIG
Cut-in	284 ± 22 PSIG