

MAS486GDFMXV

MASTER SERIES DUAL-FUEL RANGE 48" - 6 BURNERS + ELECTRIC GRIDDLE -
ELECTRIC OVEN - STAINLESS STEEL FINISH



Fingerprint resistant stainless steel finish

Make cleaning a breeze thanks to the fingerprint resistant finish on all knobs, handles and oven door surfaces.

Bertazzoni signature counter-deep maintop

Bertazzoni signature stainless counter-deep maintop is designed to install flush with most kitchen countertops for a perfectly integrated look. Precise and flexible heating is generated through 6 Mono-bloc aluminum burners. 2 x 19000 BTUs power burners with dual ring of flame boil water in 6 minutes flat. The stainless steel electric griddle comes with a handy integrated cover.

Extra large oven with dual convection

The 4.7 cu.ft electric main oven with dual horizontal convection allows even baking and roasting on 7 shelf levels. A 2.4 cu.ft auxiliary electric oven with broiler helps prepare multiple dishes at the same time. Bertazzoni ovens are equipped with an extra-large high-power broiler for broiling and grilling.

Advanced programming and controls for the oven

The elegant temperature gauge for control of oven temperature during pre-heating and baking is a signature of every Bertazzoni range.

Best-in-class features and design

The soft-motion oven door with edge-to-edge tempered glass is a masterpiece of European engineering and makes the oven door very easy to wipe clean. The range is equipped with an elegant stainless steel toe kick matching the finish of the range.

GENERAL CHARACTERISTICS

Worktop	6 gas burners with 2 lateral dual ring power burner + electric griddle
Burners	Aluminum with brass medallion on power burner
Pan support	Cast iron
Upstand/Lid cover	1" stainless steel island trim
Knobs	Metal
Cooking modes	9
Tray	1 baking tray with grill trivet
Shelves	1 telescopic + 1 standard
Levels	Lateral grids
Inner door	3 layer tempered glass
Door hinges	Soft motion
Auxiliary oven cooking modes	5
Auxiliary oven shelves	1 telescopic + 1 standard
Auxiliary oven levels	Lateral grids
Legs	Stainless steel ø 2 3/8 inches
Toe kick	Integrated stainless steel toe kick included

TECHNICAL SPECIFICATIONS

Electrical requirements	120/208 V 60HZ - 5400W 120/240 V 60HZ - 6700W 40A
Warranty	2 years parts & labor
Packaging dimensions	H:42 1/8 W:51 15/16 D:29 15/16

ACCESSORIES SECTION

DSMASDKSG	Satin gold décor set - 12 knobs
DSMASDKSB	Black nickel décor set - 12 knobs
DSMASHSG	Satin gold décor set - 2 handle terminals
DSMASHSB	Black nickel décor set - 2 handle terminals
CIG36	Cast iron griddle

MAS486GDFMXV

MASTER SERIES DUAL-FUEL RANGE 48" - 6 BURNERS + ELECTRIC GRIDDLE -
ELECTRIC OVEN - STAINLESS STEEL FINISH



DIMENSIONS

SIDE VIEW

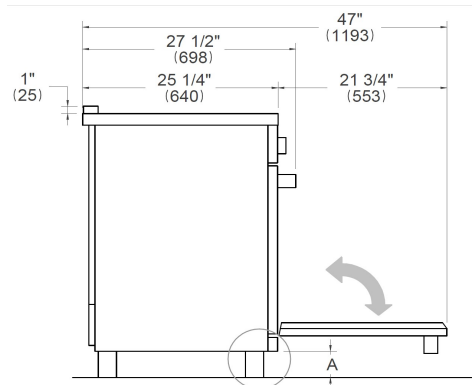

FRONT VIEW

LEG DETAILS

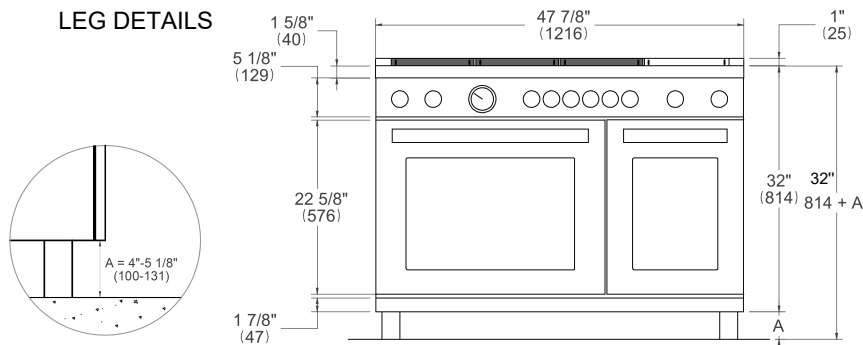

WORKTOP DETAILS

REAR VIEW

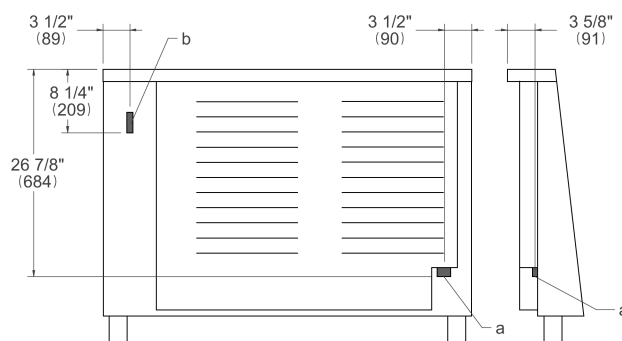
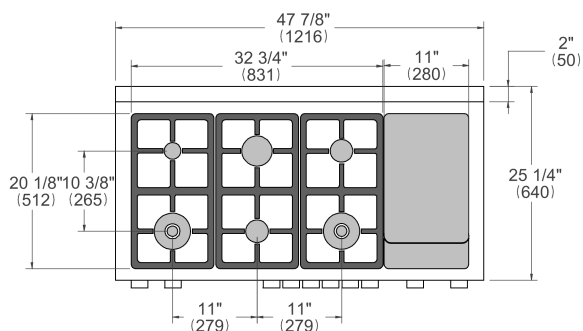

INSTALLATION

E A properly-grounded horizontally mounted electrical receptacle should be installed no higher than 3" (7.6 cm) above the floor, no less than 2" (5 cm) and no more than 8" (20,3 cm) from the left side (facing product). Check all local code requirements.

G Install agency approved, properly sized manual shut-off valve at max. height of 3" from floor, 2" min. height/ 8" max. height from the right side (facing product). Use approved shut-off valve & regulator gas connection, properly sized flex or rigid pipe. Check all local code requirements.

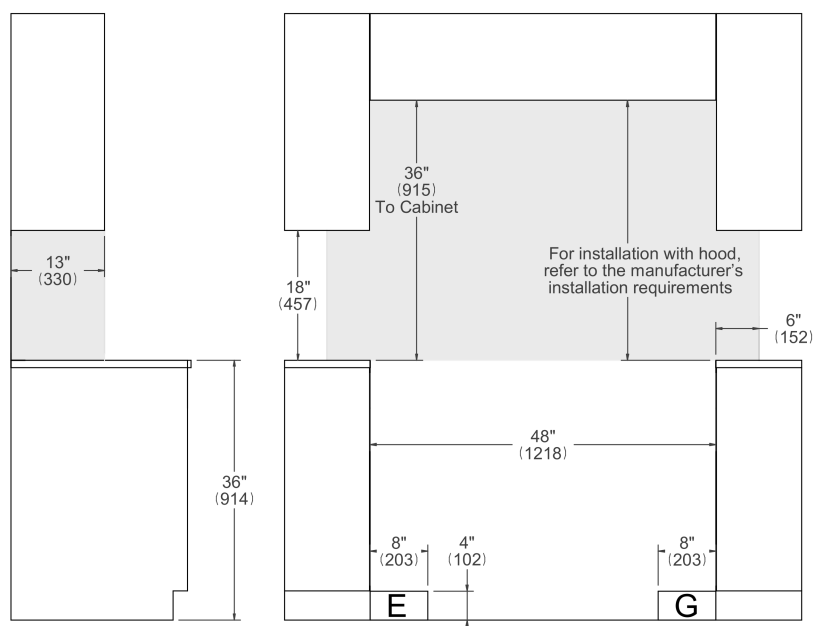

NOTE

a. Electrical Connection
b. Gas Connection

Disclaimer: while every effort has been made to insure the accuracy of the information contained in this document, Fratelli Bertazzoni reserves the right to change any part of the information at any time without notice. For detailed installation specifications consult the installation manual. Fratelli Bertazzoni, Bertazzoni and the winged wheel brand icon are registered trademarks of Bertazzoni Spa.