



HOSHIZAKI

Service Manual

Modular Flaker

Models

F-450 to I002M_J(Z)(-C)(-SC)

FD-650 to FD-I002M_J(Z)(-C)(-CB)

N-2, N-3 and Later Auxiliary Codes



hoshizakiamerica.com

Number: 73253
Issued: 5-22-2024
Revised: 9-23-2024

⚠ WARNING

Only qualified service technicians should install and service the appliance. To obtain the name and phone number of your local Hoshizaki Certified Service Representative, visit www.hoshizakiamerica.com. No service should be undertaken until the technician has thoroughly read this Service Manual. Failure to service and maintain the appliance in accordance with this manual will adversely affect safety, performance, component life, and warranty coverage and may result in costly water damage. Proper installation is the responsibility of the installer. Product failure or property damage due to improper installation is not covered under warranty.

Hoshizaki provides this manual primarily to assist qualified service technicians in the service of the appliance.

Should the reader have any questions or concerns which have not been satisfactorily addressed, please call, send an e-mail message, or write to the Hoshizaki Technical Support Department for assistance.

Phone: 1-800-233-1940; (770) 487-2331

Fax: 1-800-843-1056; (770) 487-3360

E-mail: techsupport@hoshizaki.com

HOSHIZAKI AMERICA, INC.

618 Highway 74 South

Peachtree City, GA 30269

Attn: Hoshizaki Technical Support Department

NOTE: To expedite assistance, all correspondence/communication **MUST** include the following information:

- Model Number _____
- Serial Number _____
- Complete and detailed explanation of the problem.

IMPORTANT

This manual should be read carefully before the appliance is serviced. Read the warnings and guidelines contained in this manual carefully as they provide essential information for the continued safe use, service, and maintenance of the appliance. Retain this manual for any further reference that may be necessary.

CONTENTS

Important Safety Information	5
I. Construction and Water/Refrigeration Circuit Diagram	7
A. Construction	7
1. Air-Cooled Models	7
2. Water-Cooled Models	8
3. Remote Air-Cooled Models	9
4. Low-Side, Parallel Rack System Models	10
B. Icemaking Unit	11
C. Water/Refrigeration Circuit Diagram.....	12
1. Air-Cooled Models	12
2. Water-Cooled Models	13
3. Remote Air-Cooled Models	14
4. Low-Side, Parallel Rack System Models	15
II. Sequence of Operation and Service Diagnosis	16
A. Sequence of Operation Flow Chart.....	16
1. Icemaking and Drain Cycle	16
2. Shutdown	17
B. Service Diagnosis	18
C. Control Board Check	25
D. Bin Control Check and Adjustment.....	30
E. Float Switch Check and Cleaning	39
F. Diagnostic Tables	41
III. Controls and Adjustments	44
A. Control Board	44
1. Control Board Layout	45
2. LED Lights and Audible Alarm Safeties	46
3. Ice Purge Cycle Bypass.....	47
B. Controls and Adjustments	48
1. Default Dip Switch Settings	48
2a. N-2 Auxiliary Code -	48
2b. N-3 Auxiliary Codes and later -	49
3. Drain Frequency Control (S2 dip switch 4)	49
4. Continuous Dispensing Timer (S2 dip switch 5 & 6).....	49
5. Bin Control Selector (S2 dip switch 7)	50
6. BC2 (Mech. Backup) Shutdown Initiation Delay (S2 dip switch 8).....	50
7. BC2 (Mech. Backup) Shutdown Time (S2 Dip Switch 9)	50
8. Factory Use (S2 Dip Switch 10).....	50
C. Power Switch and Control Switch.....	51

IV. Refrigeration Circuit and Component Service Information.....	52
A. Refrigeration Circuit Service Information	52
B. Component Service Information.....	55
V. Maintenance	62
VI. Disposal.....	64
VII. Technical Information.....	65
A. Specification & Performance Data Sheets	65
1a. F-450MAJ	65
1b. F-450MAJ-C	66
2a. F-801MAJ	67
2b. F-801MAJ-C.....	68
2c. F-801MWJ.....	69
2d. F-801MWJ-C.....	70
3. F-1002MLJ.....	71
4a. F-1002MAJ	72
4b. F-1002MAJ-C.....	73
4c. F-1002MAJ-SC	74
4d. F-1002MWJ	75
4e. F-1002MWJ-C.....	76
4f. F-1002MRJZ.....	77
4g. F-1002MRJZ-C	78
4h. F-1002MRJZ-SC.....	79
5a. FD-650MAJ-C.....	80
5b. FD-650MWJ-C.....	81
5c. FD-650MRJZ-C	82
6a. FD-1002MAJ-C	83
6b. FD-1002MAJ-CB.....	84
6c. FD-1002MRJZ-C.....	85
6d. FD-1002MRJZ-CB	86
B. Wiring Diagrams.....	87
1. F-450MAJ(-C)	87
a) N-2 Auxiliary Code (Infrared Bin Control 1)	87
b) N-3 Auxiliary Code and Later (Ultrasonic Bin Control 1)	88
2. F-801M_J(-C).....	89
a) N-2 Auxiliary Code (Infrared Bin Control 1)	89
b) N-3 Auxiliary Code and Later (Ultrasonic Bin Control 1)	90
3. F-1002MAJ(-C)(-SC), F-1002MWJ(-C), F-1002MRJ(Z)(-C)(-SC), F-1002MLJ	91
a) N-2 Auxiliary Code (Infrared Bin Control 1)	91
b) N-3 Auxiliary Code and Later (Ultrasonic Bin Control 1)	92
4. FD-650M_J(Z)(-C)	93
a) N-3 Auxiliary Code and Later (Ultrasonic Bin Control 1)	93
5. FD-1002MAJ-C(-CB), FD-1002MRJZ-C(-CB)	94
a) N-3 Auxiliary Code and Later (Ultrasonic Bin Control 1)	94

Important Safety Information

Throughout this manual, notices appear to bring your attention to situations which could result in death, serious injury, damage to the appliance, or damage to property.

⚠ WARNING Indicates a hazardous situation which could result in death or serious injury.

NOTICE Indicates a situation which could result in damage to the appliance or property.

IMPORTANT Indicates important information about the installation, use, and care of the appliance.

⚠ WARNING

The appliance should be destined only to the use for which it has been expressly conceived. Any other use should be considered improper and therefore dangerous. The manufacturer cannot be held responsible for injury or damage resulting from improper, incorrect, and unreasonable use. Failure to install, operate, and maintain the appliance in accordance with this manual will adversely affect safety, performance, component life, and warranty coverage and may result in costly water damage.

To reduce the risk of death, electric shock, serious injury, or fire, follow basic precautions including the following:

- Only qualified service technicians should install and service the appliance.
- The appliance must be installed in accordance with applicable national, state, and local codes and regulations.
- Electrical connection must be hard-wired and must meet national, state, and local electrical code requirements. Failure to meet these code requirements could result in death, electric shock, serious injury, fire, or damage.
- The icemaker requires an independent power supply of proper capacity. See the nameplate for electrical specifications. Failure to use an independent power supply of proper capacity can result in a tripped breaker, blown fuse, damage to existing wiring, or component failure. This could lead to heat generation or fire.
- **THE ICEMAKER MUST BE GROUNDED.** Failure to properly ground the icemaker could result in death or serious injury.
- To reduce the risk of electric shock, do not touch the power switch or control switch with damp hands.
- Move the power switch to the "OFF" position and turn off the power supply before servicing. Lockout/Tagout to prevent the power supply from being turned back on inadvertently.
- Do not place fingers or any other objects into the ice discharge opening.
- Do not make any alterations to the appliance. Alterations could result in electric shock, injury, fire, or damage.

⚠ WARNING, continued

- The appliance is not intended for use by persons (including children) with reduced physical, sensory, or mental capabilities, or lack of experience and knowledge, unless they have been given supervision or instruction concerning use of the appliance by a person responsible for their safety.
- Children should be properly supervised around the appliance.
- Do not climb, stand, or hang on the appliance or allow children or animals to do so. Serious injury could occur or the appliance could be damaged.
- Do not use combustible spray or place volatile or flammable substances near the appliance. They might catch fire.
- Keep the area around the appliance clean. Dirt, dust, or insects in the appliance could cause harm to individuals or damage to the appliance.

Additional Warning for Remote Models

- **THE REMOTE CONDENSER UNIT MUST BE GROUNDED.** The power supply and ground connection to the remote condenser unit are supplied from the icemaker. Failure to properly ground the remote condenser unit could result in death or serious injury.
- Wire routing (conduit) and disconnect (if required) must meet national, state, and local electrical code requirements. Failure to meet these code requirements could result in death, electric shock, serious injury, fire, or damage.

NOTICE

- Follow the instructions in this manual carefully to reduce the risk of costly water damage.
- In areas where water damage is a concern, install in a contained area with a floor drain.
- Install the appliance in a location that stays above freezing. Normal operating ambient temperature must be within 45°F to 100°F (7°C to 38°C).
- Do not leave the icemaker on during extended periods of non-use, extended absences, or in sub-freezing temperatures. To properly prepare the icemaker for these occasions, follow the instructions provided in the instruction manual.
- Do not place objects on top of the appliance.
- The dispenser unit/ice storage bin is for ice use only. Do not store anything else in the dispenser unit/ice storage bin.

I. Construction and Water/Refrigeration Circuit Diagram

A. Construction

1. Air-Cooled Models

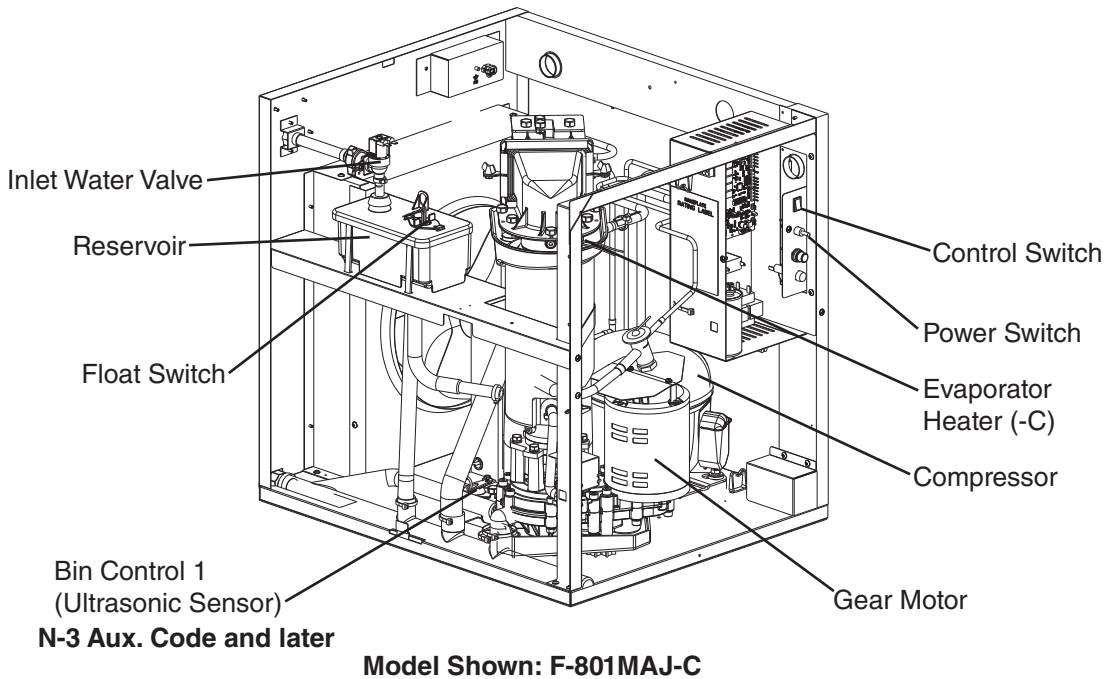
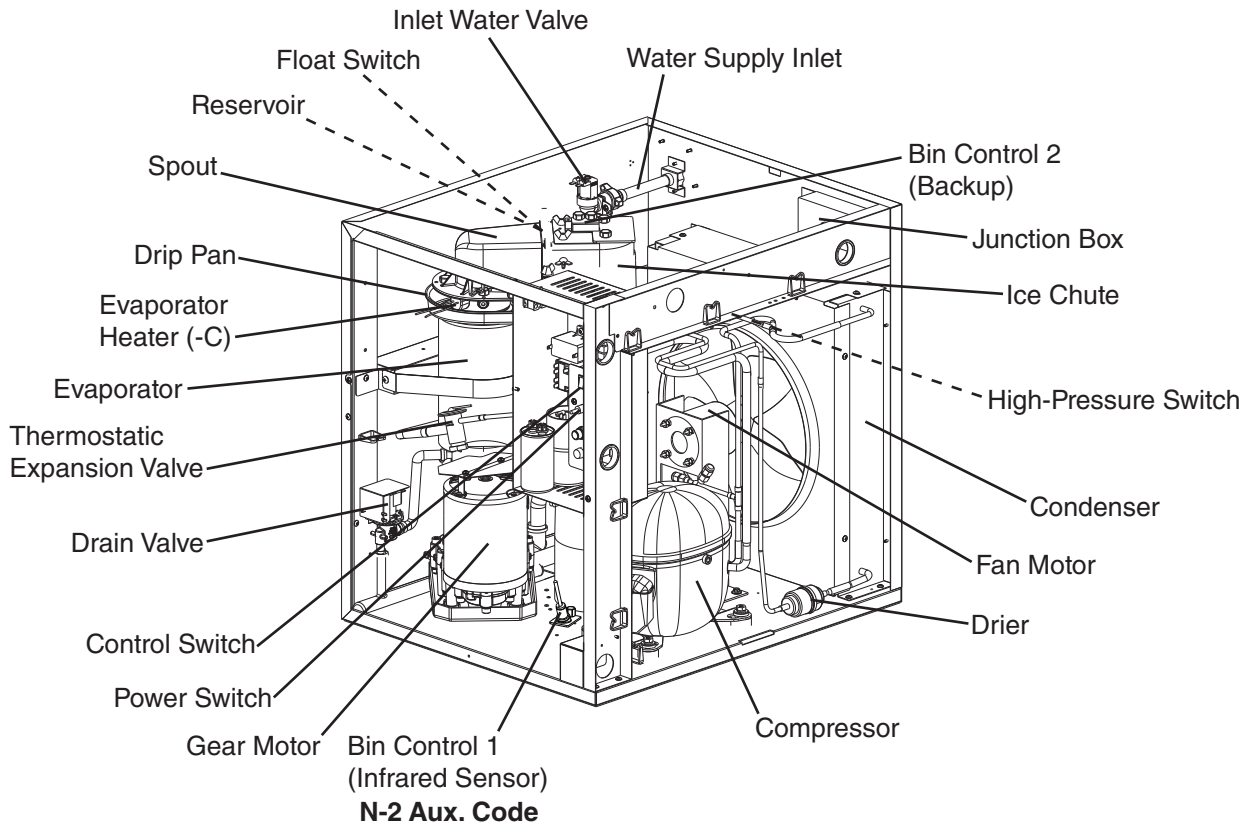

2. Water-Cooled Models

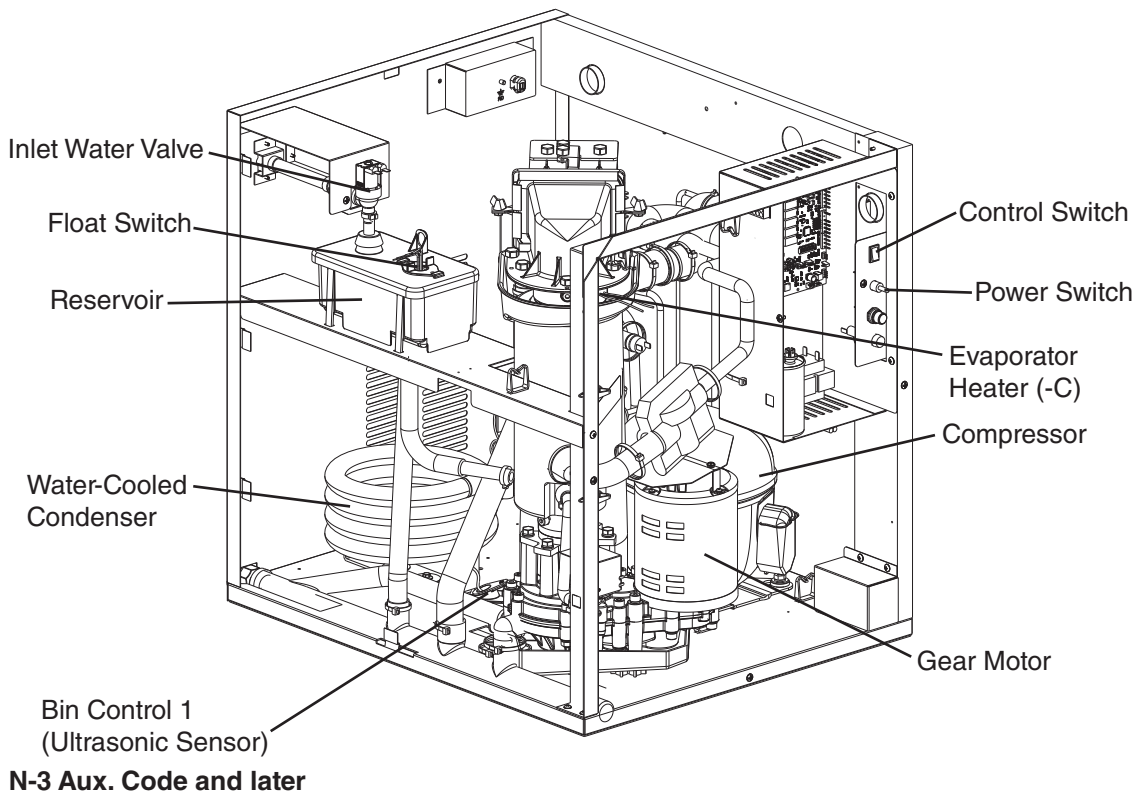
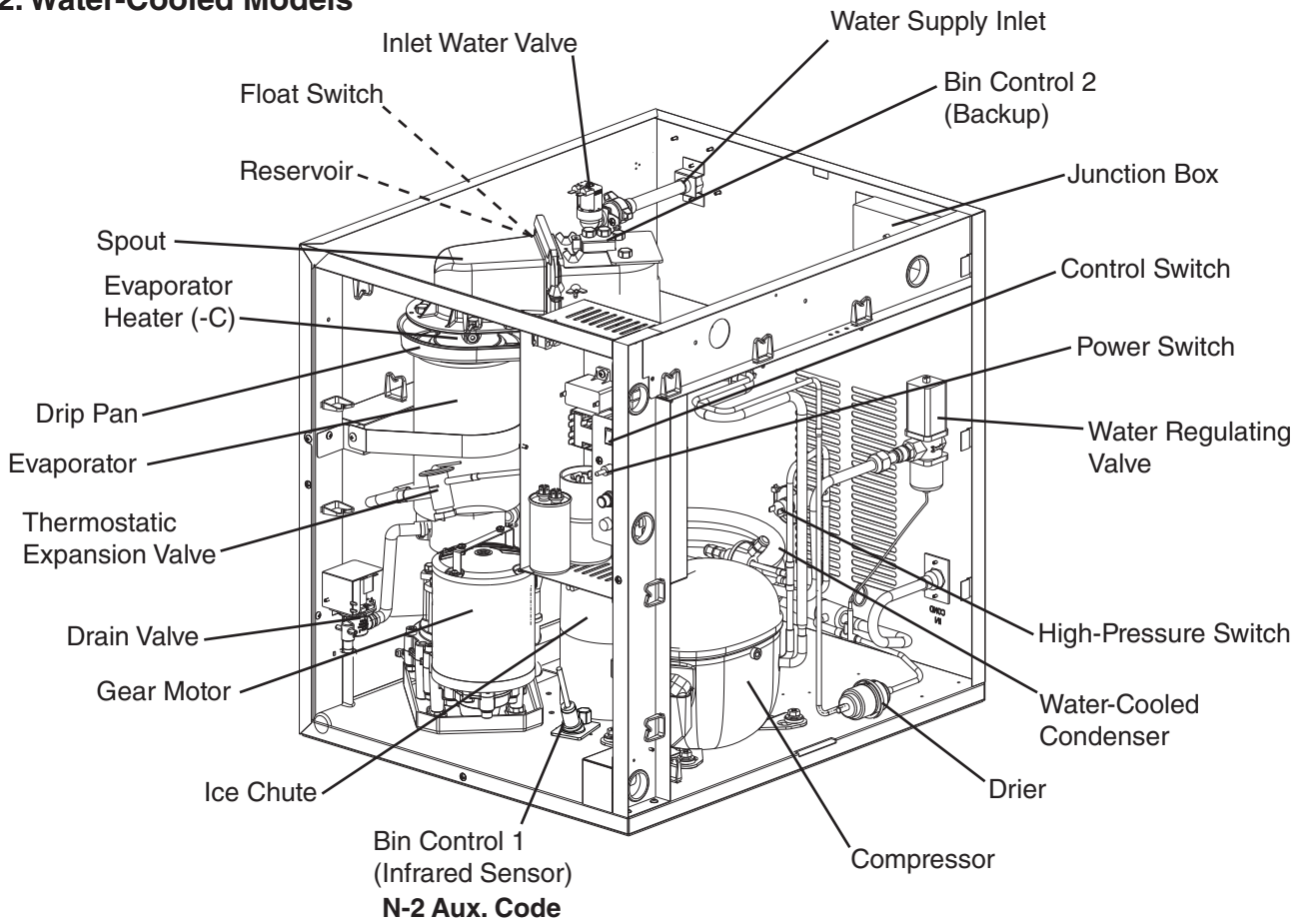

Model Shown: F-801MWJ-C

3. Remote Air-Cooled Models

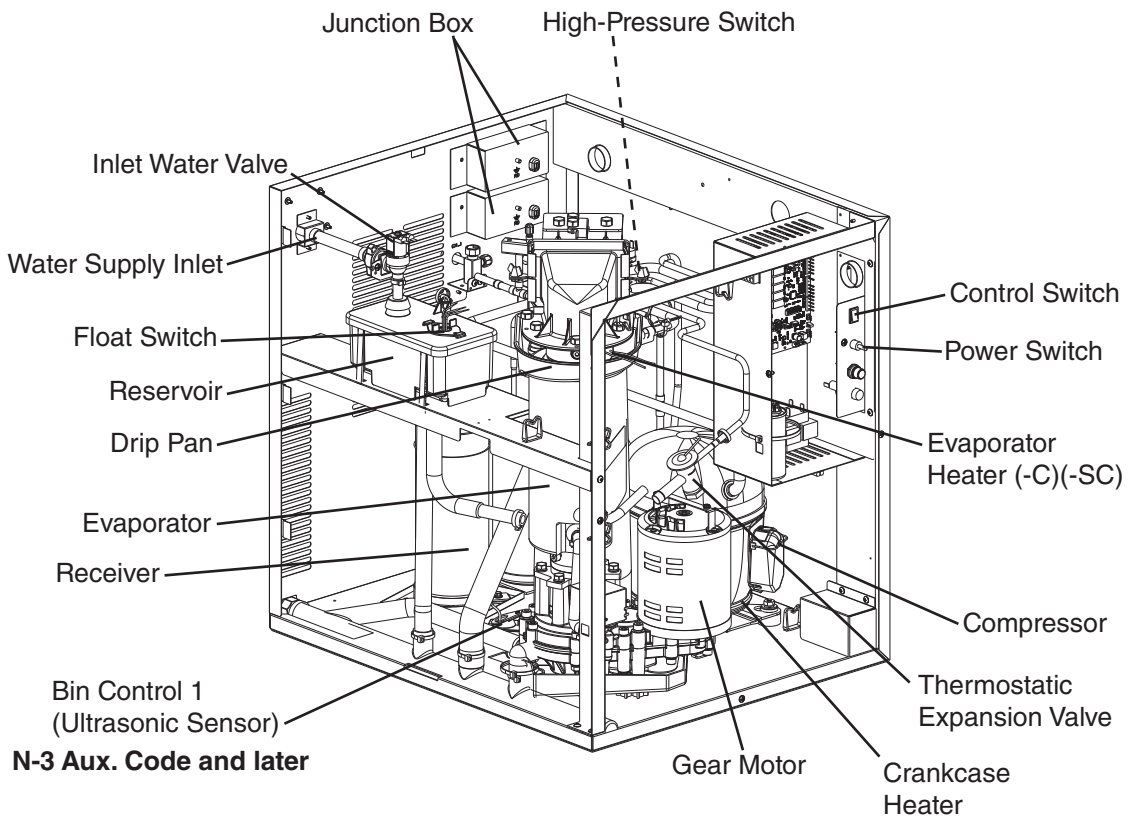
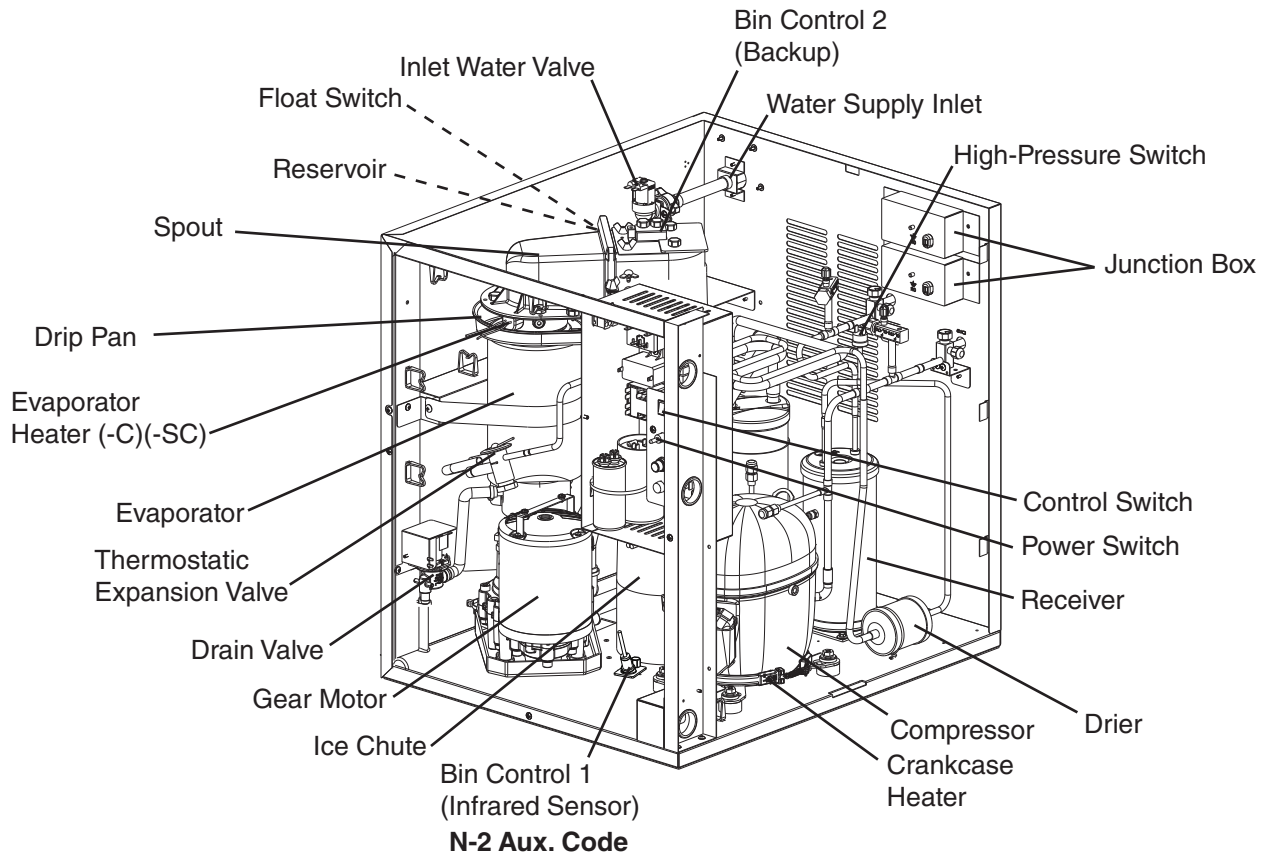

Model Shown: F-1002MRJZ-C

4. Low-Side, Parallel Rack System Models

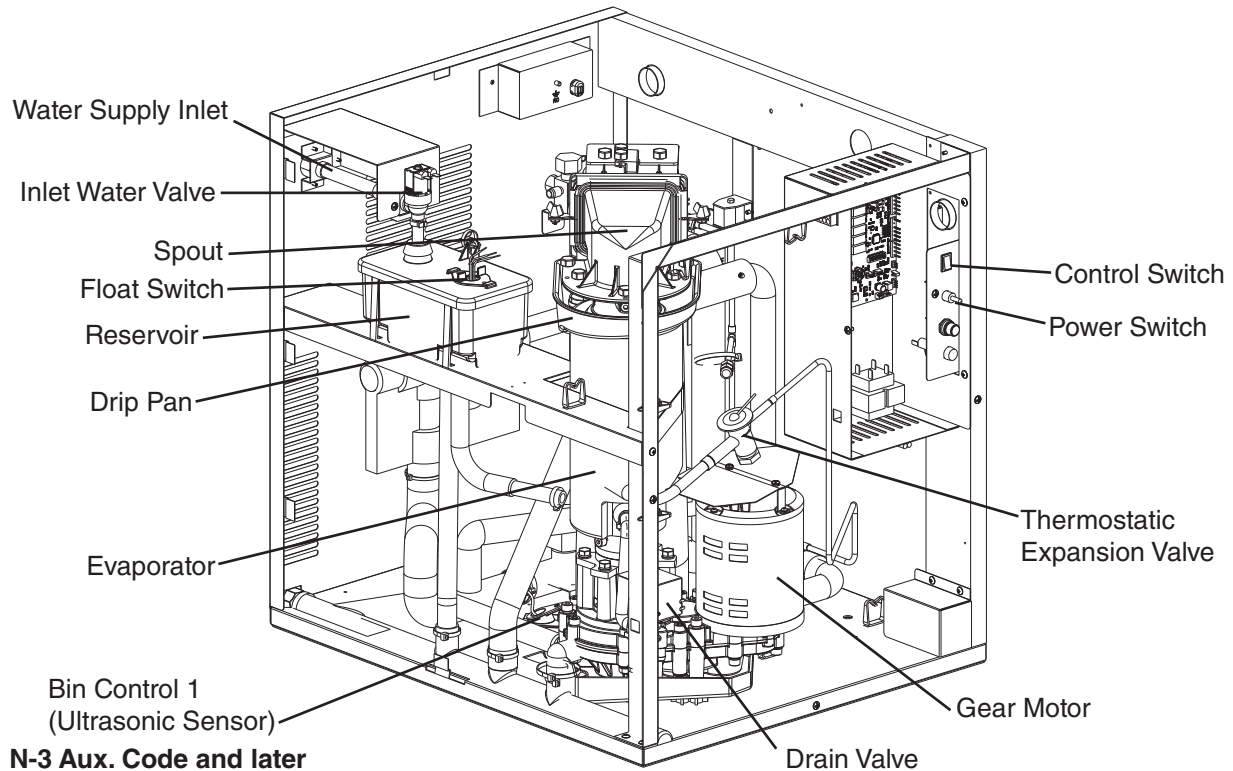
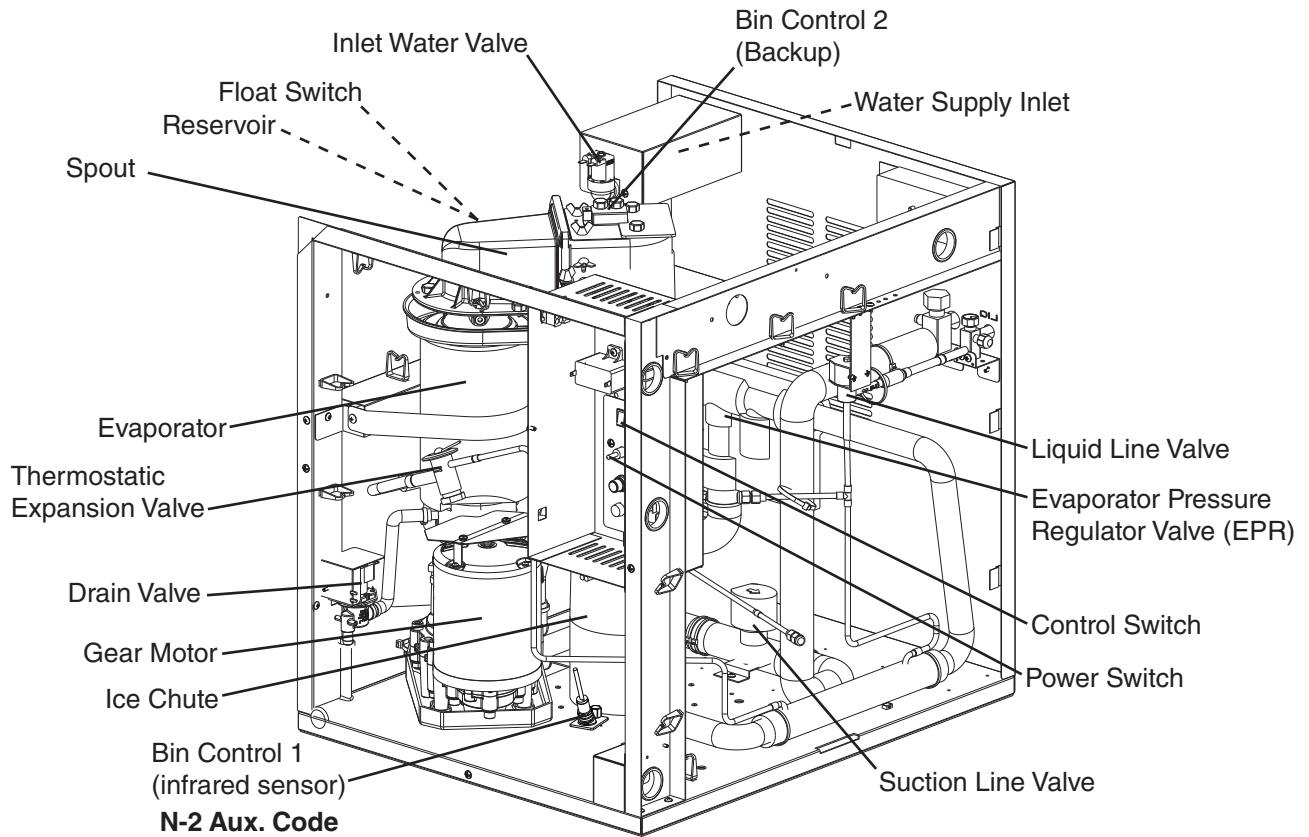

Model Shown: F-1002MLJ

B. Icemaking Unit

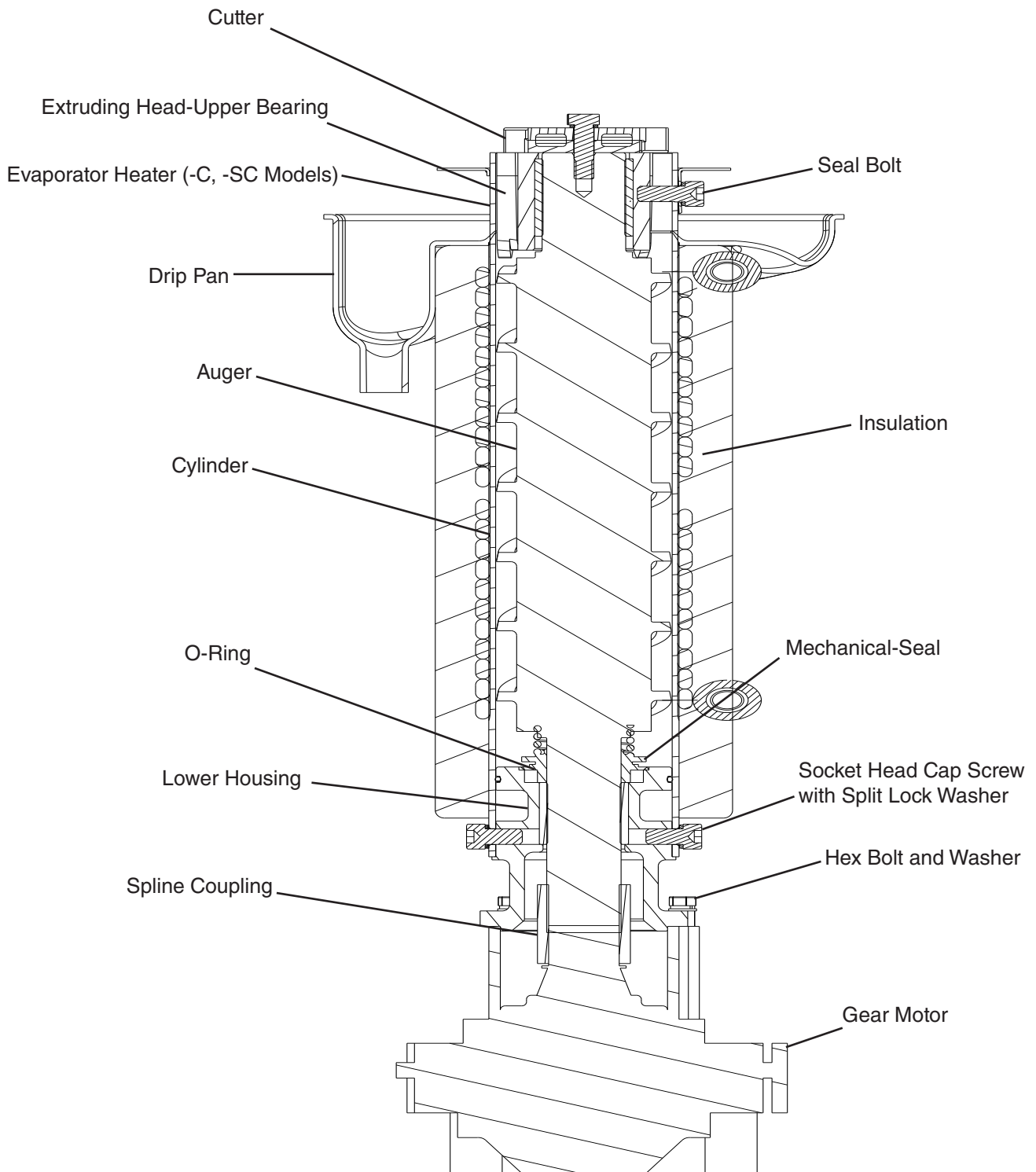

C. Water/Refrigeration Circuit Diagram

1. Air-Cooled Models

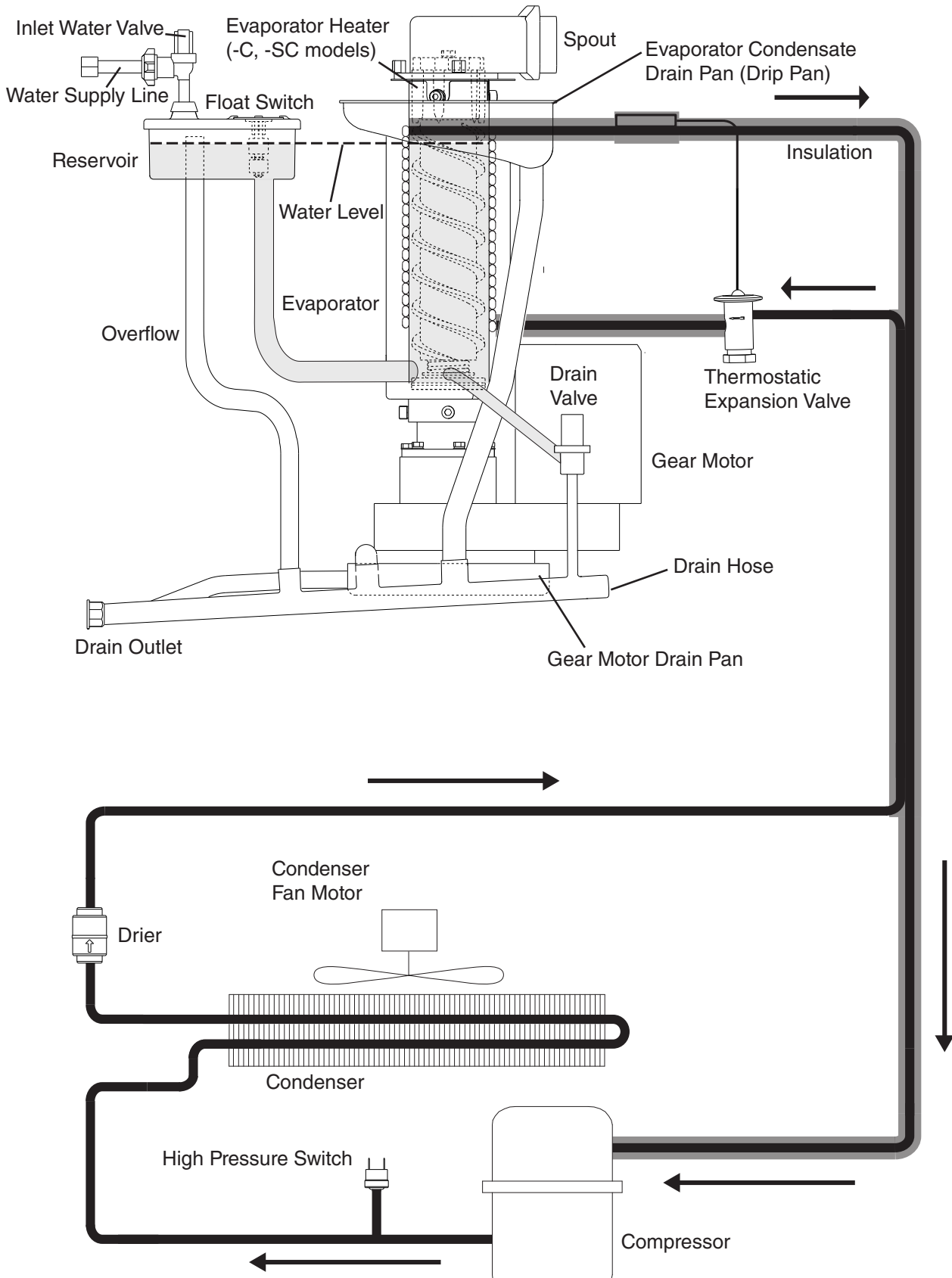

2. Water-Cooled Models

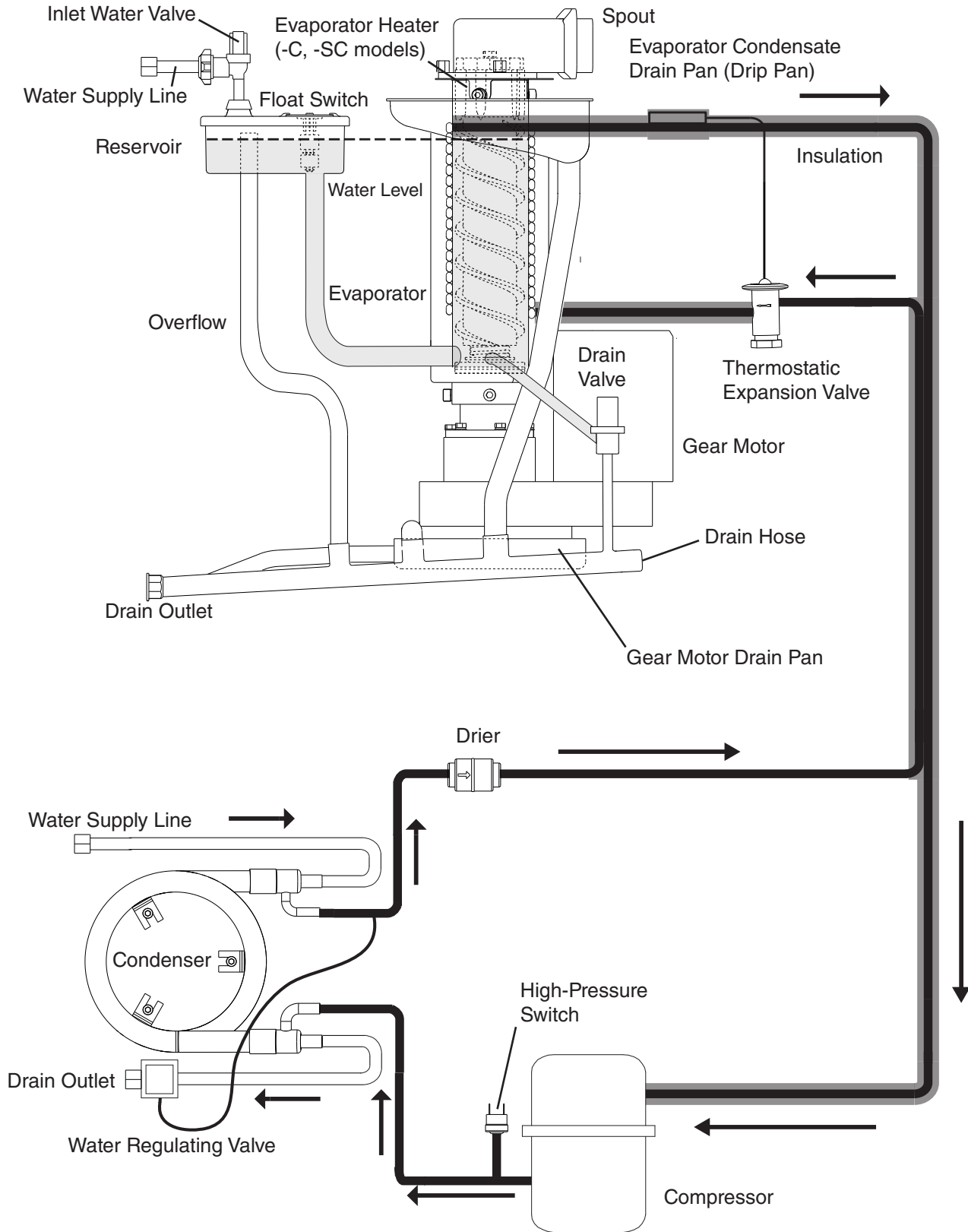

3. Remote Air-Cooled Models

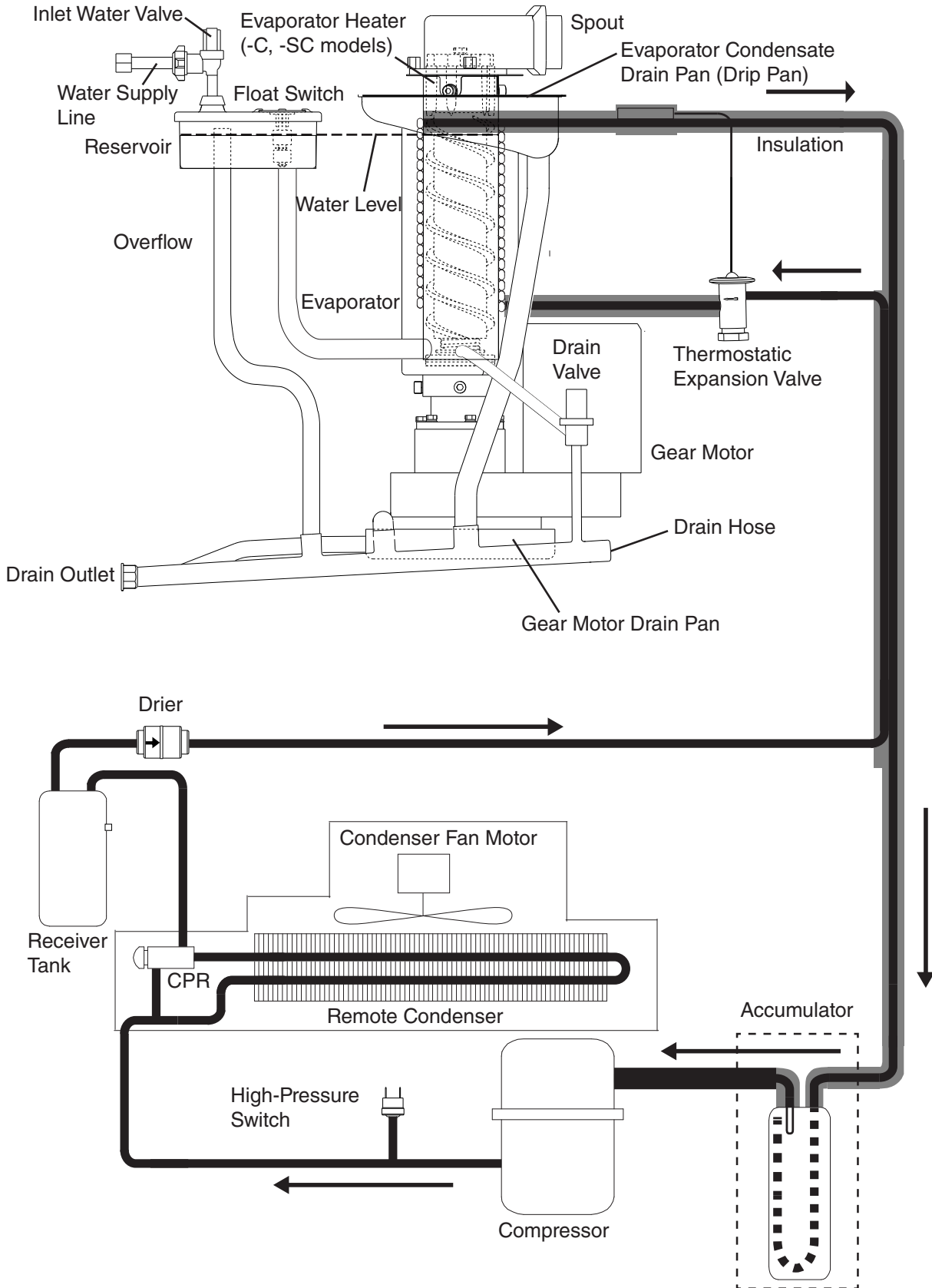

II. Sequence of Operation and Service Diagnosis

A. Sequence of Operation Flow Chart

1. Icemaking and Drain Cycle

Control Board Sequence of Operation Flow Chart - Icemaking and Drain Cycle

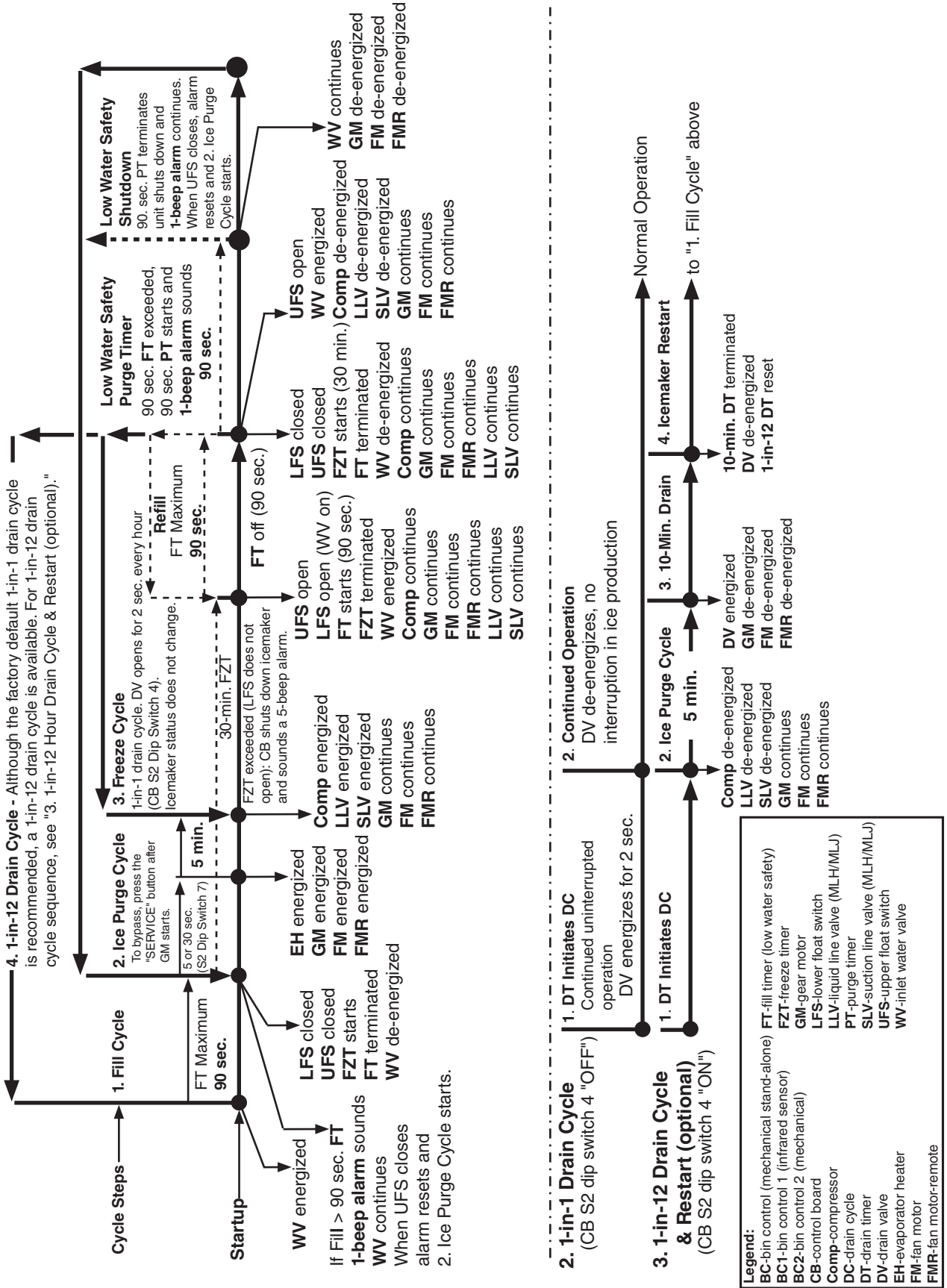

2. Shutdown

Control Board Sequence of Operation Flow Chart - Shutdown

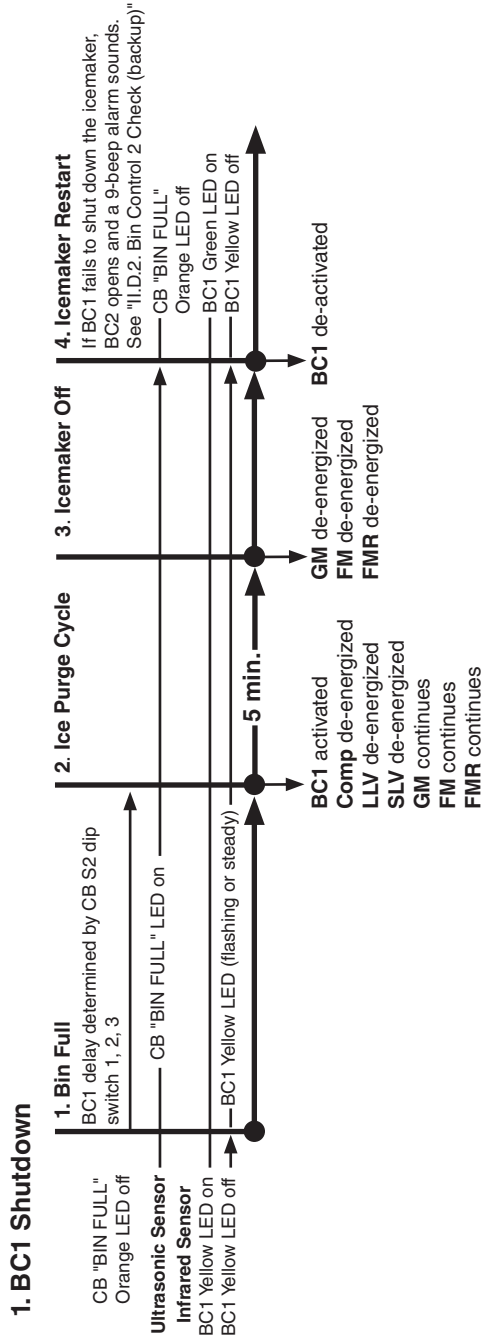

2. BC2 Shutdown (backup)

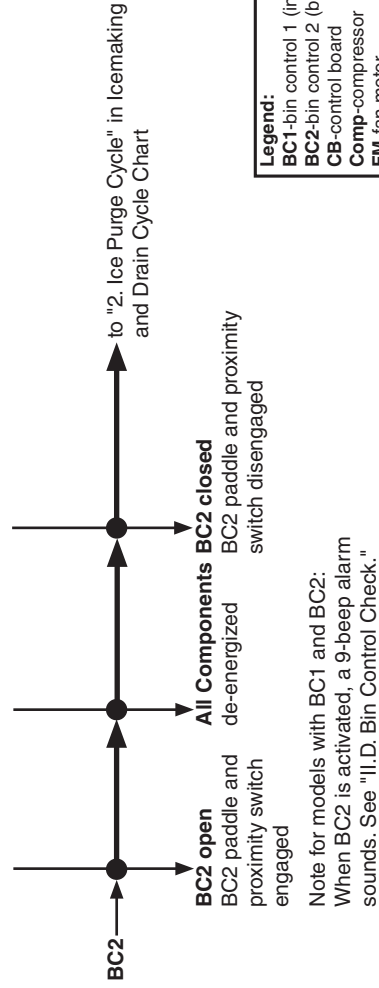

Legend:	
BC1	-bin control 1 (infrared/ultrasonic sensor)
BC2	-bin control 2 (backup)
CB	-control board
Comp	-compressor
FM	-fan motor
FMR	-fan motor-remote
GM	-gear motor
LLV	-liquid line valve (MLJ)
SLV	-suction line valve (MLJ)

B. Service Diagnosis

WARNING

- The appliance should be diagnosed and repaired only by qualified service personnel to reduce the risk of death, electric shock, serious injury, or fire.
- Risk of electric shock. Use extreme caution and exercise safe electrical practices.
- Moving parts (e.g., fan blade or auger) can crush and cut. Keep hands clear.
- **CHOKING HAZARD:** Ensure all components, fasteners, and thumbscrews are securely in place after the appliance is serviced. Make sure that none have fallen into the dispenser unit/ice storage bin.
- Make sure all food zones in the icemaker and dispenser unit/ice storage bin are clean after service.

1. Ice Production Check

To check production, prepare a bucket or pan to catch the ice and a set of scales to weigh the ice. After the appliance has operated for 10 to 20 min., catch the ice production for 10 min.. Weigh the ice to establish the batch weight. Multiply the batch weight by 144 for the total production in 24 hours. When confirming production or diagnosing low production, reference production information found in "VII.A. Specification and Performance Data."

2. Diagnostic Procedure

This diagnostic procedure is a sequence check that allows you to diagnose the electrical system and components. Before proceeding, check for correct installation, proper voltage per appliance nameplate, and adequate water pressure (10 PSIG to 113 PSIG).

Note: • When checking high voltage (115VAC), always choose a neutral (W) wire to establish a good neutral connection.

- When checking low voltage (24VAC), always choose a neutral (LBU) wire to establish a good neutral connection.
 - When checking control board DC voltage (5VDC), always place the red positive test lead from the multimeter to CB K7:1 red connector (open) pin 1, (closest to CB K8:2 white connector. See "II.C. Control Board Check."
 - **N-2 Auxiliary Code:** When checking BC1 (infrared sensor) (24VDC), check that the infrared sensor green LED is on. This green LED confirms 24VDC power from CB K6 to the infrared sensor and remains on constantly. If green LED is not on, check for 24VDC from CB K6 #1 (DBU) to CB K6 #3 (BR). See "II.D.1a. Bin Control Check."
 - **N-3 Auxiliary Code and Later:** When checking BC1 (ultrasonic sensor), check that the CB orange "BIN FULL" LED comes on when an object is placed in front of the sensor. This orange LED confirms power from CB K10 to the ultrasonic sensor and remains on constantly. If CB orange "BIN FULL" LED does not come on, see "II.D.1b. Bin Control Check." Note: It is strongly advised to keep a known "good" ultrasonic sensor on your truck, for troubleshooting assistance.
 - To speed up the diagnostic process, the 5-min. ice purge cycle may be bypassed by pressing the "SERVICE" button on the control board after the gear motor starts. **WARNING! Risk of electric shock. Care should be taken not to touch live terminals.**
 - If the icemaker is in alarm, see "III.A.2. LED Lights and Audible Alarm Safeties."
 - FM/FMR and EH (-C model except FD-650) energize when "GM" LED turns on.
 - MLJ Model: CB X1 relay energizes LLV and SLV.
 - CB monitors the following switches with 5VDC during the icemaking process: Control Switch (CS), High-Pressure Switch (HPS), Float Switch (FS), Compressor Control Relay/Gear Motor Protect Relay (CCR/GMPR), and Bin Control 2 (mechanical stand-alone or backup). When 5VDC is present across any of these switches, the switch is open.
- 1) Remove the front panel, then move the power switch to the "OFF" position. Move the control switch to the "DRAIN" position, then move the power switch back to the "ON" position. Replace the front panel in its correct position.
 - 2) Allow the water system to drain for 5 min.
 - 3) Remove the front panel. Move the power switch to the "OFF" position, then turn off the power supply.
 - 4) Remove the control box cover and access CB.
 - 5) Check the CB S2 dip switch settings, see "III.B.1. Default Dip Switch Settings" to assure that they are in the correct positions. For proper operation of BC1 (infrared or ultrasonic sensor), confirm that S2 dip switch 7 is in the "ON" position.

6) **Startup—CB "POWER" LED is on.** Turn on the power supply, then move the power switch to the "ON" position. Make sure the control switch is in the "ICE" position. CB "POWER" LED and "BIN FULL" orange LED is off.

Diagnosis CB "POWER" LED: Check that CB "POWER" LED is on. If not, check for 115VAC at control transformer; black (BK) wire to neutral (W). If 115VAC is not present, check the power switch and breaker. If 115VAC is present, check control transformer continuity. Replace as needed. Next, check for 24VAC at control transformer red (R) wire to neutral (LBU). If 24VAC is not present, check control transformer continuity. Replace as needed. If 24VAC is present, check 24VAC 1A fuse. If fuse is good, check for 24VAC at CB K8 #1 (W/R) to CB K8 #2 (LBU). If 24VAC is present and "POWER" LED is off, replace CB.

Diagnosis BC2 (mechanical backup): Check that the actuator paddle is properly positioned. Check continuity across BC2. If open, replace BC2. Next, check VDC at CB K8 #3 (GY) to CB K8 #4 (GY). When BC2 is closed 0VDC is read. Move the actuator paddle to open BC2. When open, 5VDC is present between CB K8 #3 (GY) and CB K8 #4 (GY). If 5VDC is not present when BC2 is open, replace CB. Return actuator to its normal position.

• **N-2 Auxiliary Code - Diagnosis BC1 (infrared/ultrasonic sensor):** If "POWER" LED is on and BC1 green LED is off, check 24VDC at CB K6 #1 (DBU) to CB K6 #3 (BR). If 24VDC is not present, confirm S2 dip switch 7 is in the "ON" position. If S2 dip switch 7 is in the "ON" position and 24VDC is not present, replace CB. If BC1 orange LED is on or flashing, move ice away from lens. If no ice is present, clean the lens with a warm, clean damp cloth. If cleaning the lens does not work, replace BC1.

• **N-3 Auxiliary Code and Later - Diagnosis BC1 (ultrasonic sensor):** If CB "POWER" LED is on and BC1 orange "BIN FULL" LED is on, check that the BC1 is connected to the CB white K10 connector. If not, connect BC1 wire connector to CB K10 connector. After 30 seconds, CB orange "BIN FULL" LED will turn off. If not, check for ice in front of sensor lens. If no ice is present, clean the lens with a warm, clean damp cloth. If cleaning the lens does not work, replace BC1.

7) **Fill Cycle – "WTRIN" LED is on.** Reservoir is empty and LFS and UFS are open. 90-sec. FT starts. WV energizes and fill cycle starts. LFS closes. Nothing occurs at this time. Reservoir continues to fill until UFS closes. When UFS closes, WV de-energizes, 90-sec. FT is terminated, and CB "WTRIN" LED turns off. 30-min. FZT and 30-sec. GM delay timer start. If UFS remains open longer than 90 sec. after LFS opens, FT exceeded and CB sounds a 1-beep alarm. WV remains energized until UFS closes. Alarm resets automatically when UFS closes. **Diagnosis:** If reservoir is empty and "WTRIN" LED is off, confirm LFS status. See "II.E.1. Float Switch Check." If LFS is open and "WTRIN" LED is off, replace CB. If "WTRIN" LED is on, check that the reservoir fills. If not, check water supply line shut-off valve, water filters, and WV screen. If "WTRIN" LED is on and WV is off, check CB K2 #8 (O) to a neutral (LBU) for 24VAC. If 24VAC is not present, check CB K2 #9 (W/R) to a neutral (LBU) for 24VAC. If 24VAC is present on CB K2 #9 (W/R) and not on CB K2 #8 (O), replace CB. If 24VAC is present on CB K2 #8 (O), check continuity through WV solenoid. If open, replace WV. If WV is energized and refill exceeds FT with no water in the reservoir, check for DV leaking. If reservoir is full and overflowing check for open UFS. See "II.E.1. Float Switch Check." If UFS is closed, check that WV de-energizes. If not, check CB K2 #8 (O) to a neutral (LBU) for 24VAC. If 24VAC is present, replace CB. If WV de-energizes and water continues to fill the reservoir, replace WV.

- 8) **Ice Purge Cycle – "GM" LED is on.** 30-sec. GM delay timer terminates. GM, CCR/GMPR, FM/FMR, and EH (-C model except FD-650) energize. Once CCR/GMPR energizes, 5VDC circuit closes through CCR/GMPR terminal #3 (W/O) and terminal #5 (W/O) and CB K9 #5 (W/O) and K9 #6 (W/O). After 5VDC circuit closes, 5-min. ice purge timer starts. To bypass the 5-min. Ice Purge Cycle, press the "SERVICE" button on CB after the "GM" LED turns on. **WARNING! Risk of electric shock. Care should be taken not to touch live terminals.** **Diagnosis:** If "GM" LED is off, check that UFS closes and WV de-energizes. If UFS is closed, 30 sec. has passed, and "GM" LED remains off, replace CB. If "GM" LED is on and GM is off, check CB K1 #2 (BK) to a neutral (W) for 115VAC. If 115VAC is not present, check 115VAC power supply. If 115VAC is present, check CB K1 #3 (BK) to a neutral (W). If 115VAC is present on CB K1 #2 (BK) and not on CB K1 #3 (P), replace CB. If 115VAC is present on CB K1 #3 (P), check GM fuse, GM internal protector, GM windings and capacitor, and GM coupling between auger and GM. When GM energizes, CCR/GMPR energizes starting 5-min. ice purge timer. If FM/FMR does not start, check FM/FMR capacitor, FM/FMR windings, and FM/FMR bearings.
- 9) **Freeze Cycle – "COMP" and "GM" LEDs are on.** The 5-min. ice purge timer terminates. GM, EH, CCR, and FM/FMR continue. Comp or LLV/SLV (MLJ model) energize. Ice production starts 4 to 6 min. after Comp or LLV/SLV (MLJ model) energize depending on ambient and water conditions. As ice is produced, the water level in the reservoir drops. UFS opens. Nothing happens at this time. When LFS opens, WV energizes and refill cycle begins, FZT terminates, and FT starts.
- FZT: 30-Min. Freeze Safety Timer –** FZT starts when UFS closes and terminates when LFS opens. If LFS does not open within 30 min. of UFS closing, CB shuts down the icemaker and sounds a 5-beep alarm. See "III.A.2. LED Lights and Audible Alarm Safeties." To reset, turn the power supply off and on again. See "II.F. Diagnostic Tables" for troubleshooting details.
- Icemaker Diagnosis (CCR/GMPR):** 5-min. ice purge timer terminates, CB "COMP" LED is on and COMP or LLV/SLV (MLJ model) energizes. If not, check for 5VDC between CB K7:1 red connector (open) pin 1 (closest to CB K8:2 white connector) and CB K9 connector #5 (W/O). If 5VDC is not present, replace CB. If 5VDC is present, check for 5VDC between CB K7:1 red connector (open) pin 1, (closest to CB K8:2 white connector) and CB K9 connector #6 (W/O). If 5VDC is present and CB "Comp" LED is off (CR, COMP, or LLV/SLV (MLJ model) not energized), replace CB. If 5VDC is not present, check for 115VAC between CCR/GMPR terminal #7 (O) to CCR/GMPR terminal #8 (W) for 115VAC. If 115VAC is not present (GM not energized), see step 8 above. If 115VAC is present and CCR/GMPR contacts are open (5VDC present between CCR/GMPR terminals #3 (W/O) and #5 (W/O)), check CCR/GMPR solenoid voltage and solenoid continuity. Replace CCR/GMPR if necessary.
- Icemaker Diagnosis (COMP or LLV/SLV (MLJ model)):** If "COMP" LED is on and COMP or LLV/SLV (MLJ model) is not energized, check CB X1 relay BK wire to a neutral (W) and CB X1 relay V or R wire to a neutral (W) for 115VAC. If 115VAC is present on CB X1 BK wire and not on CB X1 V or R wire, replace CB. If 115VAC is present on CB X1 V or R wire and COMP or LLV/SLV (MLJ model) is not energized, check for 115VAC at CB X1 Comp relay, Comp or LLV/SLV (MLJ model). Check Comp internal overload (motor protector), start relay, and capacitors. Check LLV/SLV (MLJ model) solenoid continuity.

10) **Refill Cycle – "GM", "COMP", and "WTRIN" LEDs are on.**

LFS opens. WV energizes and 90-sec. FT starts. Comp or LLV/SLV (MLJ model), GM, CCR/GMPR, and FM/FMR continue. LFS closes. Nothing occurs at this time. Reservoir continues to fill until UFS closes. When UFS closes, WV de-energizes, 90-sec. FT terminates, and 30-min. FZT starts. If UFS remains open longer than 90 sec. after LFS opens, FT exceeded and CB sounds a 1-beep alarm. WV remains energized until UFS closes. Alarm resets automatically when UFS closes.

Diagnosis – Confirm that the water level has dropped and the UFS and LFS are open. See "II.E.1. Float Switch Check." Check that "WTRIN" LED is on. If LFS is open and "WTRIN" LED is off, replace CB. If "WTRIN" LED is on, check that the reservoir fills. If not, check water supply line shut-off valve, water filters, and WV screen. If "WTRIN" LED is on and WV is off, check CB K2 #8 (O) to a neutral (LBU) for 24VAC. If 24VAC is not present, check CB K2 #9 (W/R) to a neutral (LBU) for 24VAC. If 24VAC is present on CB K2 #9 (W/R) and not on CB K2 #8 (O), replace CB. If 24VAC is present on CB K2 #8 (O), check continuity through WV solenoid. If open, replace WV. If WV is energized and refill exceeds FT with no water in the reservoir, check for DV leaking. If reservoir is full and overflowing check for open UFS. See "II.E. Float Switch Check and Cleaning." If UFS is closed, check that WV de-energizes. If not, check CB K2 #8 (O) to a neutral (LBU) for 24VAC. If 24VAC is present, replace CB. If WV de-energizes and water continues to fill the reservoir, replace WV.

Note: Each time UFS closes, 30-min. freeze timer starts. The 30-min. freeze timer resets when UFS closes again. If UFS does not close again within 30 min., CB shuts down the unit and sounds a 5-beep alarm every 5 sec.

See "III.A.2 LED Lights and Audible Alarm Safeties."

FT: 90-Sec. Low Water Safety Timer – When LFS opens, 90-sec. low water safety timer starts. If UFS does not close within 90 sec. after LFS opens (FT exceeded), CB sounds a 1-beep alarm and a 90-sec. shutdown cycle starts

See "III.A.2. LED Lights and Audible Alarm Safeties." Comp or LLV/SLV (MLH model) de-energizes. GM, CCR/GMPR, and EH continue. 90-sec. purge timer terminates, GM, EH, and CCR/GMPR de-energize. WV and 1-beep alarm continue until UFS closes.

11) **Drain Cycle**

- a) **1-in-1 Drain Cycle:** DV energizes once every hour when the 1-in-1 drain cycle is activated (S2 dip switch 4 in the "OFF" position (factory default position)). GM, FM/FMR, Comp, LLV/SLV (MLJ model), continue. DV energizes for 2 sec. every hour. This setting is recommended for optimum icemaker performance. The 1-in-1 drain cycle allows any sediment to drain from the evaporator without interrupting the icemaking process.
- b) **1-in-12 Drain Cycle (optional):** DV energizes once every 12 hours when the 1-in-12 drain cycle is activated (S2 dip switch 4 in the "ON" position (optional)). 12-hour drain cycle timer terminates, Comp or LLV/SLV (MLJ model) de-energize. GM, and FM/FMR continue. The 5-min. ice purge timer starts. When the 5-min. ice purge timer terminates, GM and FM/FMR de-energize. 10-min. DT starts, DV energizes. After 10-min. DT terminates, DV de-energizes icemaking process restarts and 12-hour drain cycle timer starts.

- c) **Manual Drain:** Manual drain is used when servicing evaporator components and cleaning and sanitizing the unit. When the unit is making ice and the control switch is moved to the "DRAIN" position, there is a 3-sec. delay, then Comp or LLV/SLV (MLJ models) de-energize and the 5-min. ice purge timer begins. When the 5-min. ice purge timer terminates, GM, and FM/FMR de-energize. DV energizes to drain the evaporator and reservoir. To avoid the 5-min. shutdown delay, turn off the power supply, then move the control switch to the "DRAIN" position. Turn on the power supply. DV energizes to drain the evaporator and reservoir. DV de-energizes when the control switch is moved to the "ICE" position.

3. Shutdown

- a) **BC1 (infrared sensor):** When power is supplied to the icemaker, the green LED on BC1 turns on. The green LED remains on constantly. As ice fills the storage bin to the level of activating BC1, BC1 orange LED turns on (flashing or steady). The orange LED flashes when ice is at the outer limit of its range and turns steady as ice nears. After the orange LED turns on (flashing or steady), BC1 shutdown delay timer (S2 dip switch 1, 2, 3) starts. For a typical dispenser unit application, a 100-sec. shutdown delay is recommended. When used with a standard Hoshizaki storage bin, any shutdown delay setting is acceptable. See "III.B.2a. BC1 (Infrared Sensor) Shutdown Delay (S2 dip switch 1, 2, 3)." Once BC1 shutdown delay timer terminates, Comp or LLV/SLV (MLJ models) de-energize and the 5-min. ice purge timer starts. When the 5-min. ice purge timer terminates, GM, CCR/GMPR, and FM/FMR de-energize. **Diagnosis:** See "II.D.1a. Bin Control 1 (infrared sensor) Check."
- b) **BC1 (ultrasonic sensor):** When power is supplied to the icemaker, the CB green "POWER" LED turns on. As ice fills the storage bin to the level of activating BC1, the CB BC1 orange LED turns on. After the orange LED turns on, BC1 shutdown delay timer (S2 dip switch 1, 2, 3) starts. For a typical dispenser unit application, a 100-sec. shutdown delay is recommended. When used with a standard Hoshizaki storage bin, any shutdown delay setting is acceptable. See "III.B.2b. BC1 (Ultrasonic Sensor) Shutdown Delay (S2 dip switch 1, 2, 3)." Once BC1 shutdown delay timer terminates, Comp or LLV/SLV (MLJ models) de-energize and the 5-min. ice purge timer starts. When the 5-min. ice purge timer terminates, GM, CCR/GMPR, and FM/FMR de-energize. **Diagnosis:** See "II.D.1b. Bin Control 1 (ultrasonic sensor) Check."

Note: When BC1 and BC2 are applied—If BC1 fails to shut down the icemaker, BC2 opens, CB shuts down the icemaker and sounds a 9-beep alarm.

- c) **BC2 (backup):** BC2 opens (actuator paddle engaged). CB shuts down the icemaker immediately and sounds a 9-beep alarm.
Diagnosis: See "II.D.2. Bin Control 2 Check (backup)."

4. Freeze-Up Detection - N-3 Auxiliary Codes and Later

Freeze-Up detection function is enabled when the Evaporator Thermistor is connected to the white K5 "EVAP" connection on CB.

a) **Low Evaporator Thermistor Temperature at GM Startup:**

Evaporator Thermistor (Evaporator Outlet) temperature is $<-20^{\circ}\text{C}$ (-4°F) at GM startup.
Audible 8 beep alarm. Orange "ALARM" LED blinks in sequence with audible alarm.

b) **Low Evaporator Thermistor Temperature in Ice making mode:**

Evaporator Thermistor (Evaporator Outlet) temperature reaches -30°C (-22°F).

1st detection - Comp and GM shut down, unit restarts once temperature reaches 0° .

2nd detection - Comp and GM shut down, unit restarts once temperature reaches 0° .

3rd consecutive detection - Appliance shuts down.

Audible 10 beep alarm. Orange "ALARM" LED blinks in sequence with audible alarm.

c) **Appliance Cycle Reset and CB Alarm Reset:**

Alarm Reset: Power supply or control switch turned off and on again: Appliance turns off, then re-starts at 1.Fill Cycle.

Legend: **BC1**—bin control 1 (infrared/ultrasonic sensor); **BC2**—bin control 2 (backup);
CB—control board; **CCR**—compressor control relay (formerly GMPR gear motor protect relay); **Comp**—compressor; **DV**—drain valve; **EH**—evaporator heater (-C model except FD-650); **FM**—fan motor; **FMR**—fan motor-remote; **GM**—gear motor; **LFS**—lower float switch; **LLV**—liquid line valve (MLJ model); **SLV**—suction line valve (MLJ model); **UFS**—upper float switch; **WV**—inlet water valve

C. Control Board Check

Before replacing a control board that does not show a visible defect and that you suspect is bad, always conduct the following check procedure. This procedure will help you verify your diagnosis.

- 1) Check CB S2 dip switch settings to assure that they are in the factory default position. For factory default settings, see "III.B.1. Default Dip Switch Settings."

Note: S2 dip switch 7 determines bin control application:

BC2 (mechanical backup only): S2 dip switch 7 in the "OFF" position. **WARNING! Do not put S2 dip switch 9 in the "OFF" position when S2 dip switch 7 is in the "OFF" position.**

BC1 (infrared or ultrasonic sensor) or with BC2 (backup): S2 dip switch 7 in the "ON" position.

- 2) Move the power switch to the "ON" position and move the control switch to the "ICE" position. The "POWER" LED turns on. **Diagnosis "POWER" LED:** Check that the CB "POWER" LED is on. If not, check for proper supply voltage (115VAC) input to the control transformer (power switch, breaker, and fuse). Next, check for proper low-voltage (24VAC) output from the control transformer and that the 1A fuse is good. Check for 24VAC at CB K8 #1 (W/R) to CB K8 #2 (LBU). If 24VAC is present and the "POWER" LED is off, replace CB.

- 3a) **N-2 Auxiliary Code - BC1 (infrared sensor) Power Supply (K6 connector):** CB supplies 24VDC to BC1 and BC1 green LED is on. **Diagnosis:** Check that BC1 green LED is on. If not, check for 24VDC between CB K6 #1 (DBU) and CB K6 #3 (BR). See Fig. 1. If 24VDC is not present, replace CB. If 24VDC is present, confirm that the orange LED is not flashing or steady. If BC1 orange LED is on or flashing, move ice away from lens. If no ice is present, clean the lens with a warm, clean damp cloth. If cleaning the lens does not work, replace BC1 (infrared sensor).

BC1 (infrared sensor) (24VDC) Closed
 24VDC K6 #1 (DBU) to K6 #3 (BR)
 24VDC K6 #1 (DBU) to K6 #2 (W)
 0VDC K6 #2 (W) to K6 #3 (BR)

BC1 (infrared sensor) (24VDC)
 Open (orange LED flashing or steady)
 24VDC K6 #1 (DBU) to K6 #3 (BR)
 0VDC K6 #1 (DBU) to K6 #2 (W)
 24VDC K6 #2 (W) to K6 #3 (BR)

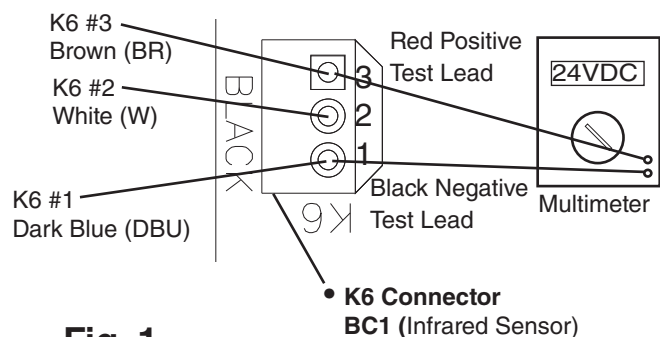

Fig. 1

3b) **N-3 Auxiliary Codes and Later - BC1 (ultrasonic sensor) Power Supply (K10 connector):** CB K10 connector is supplied with a 60 kHz signal. **Diagnosis:** Check that CB BC1 "BIN FULL" orange LED is off. Disconnect BC1 from K10 connector. See Fig. 2. CB BC1 "BIN FULL" orange LED should come on. If not, replace CB. Reconnect BC1 to K10 connector. If LED is on, move ice away from lens. If no ice is present, clean the lens with a warm, clean damp cloth. If cleaning the lens does not work, replace BC1 (ultrasonic sensor).

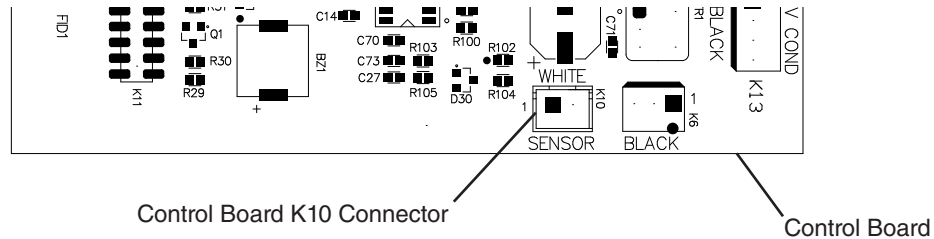

Fig. 2

4) **5VDC Output Checks:**

CB K9 Connector: Control Switch (CB K9 #1 and #2) (open contacts for icemaking, closed contacts for drain), High-Pressure Switch (CB K9 #3 and #4), Compressor Control Relay/Gear Motor Protect Relay (K9 #5 and #6).

CB K8 Connector: Bin Control 2 (K8 #3 and #4) and Float Switch (K8 #5 (common), #6 (upper), and #7 (lower)).

When checking 5VDC control voltage, always place the red positive test lead from the multimeter to the CB K7:1 red connector (open) pin 1, (closest to CB K8:2 white connector). See Fig. 3. Then place the black negative test lead from the multimeter to the corresponding pin to complete the 5VDC check.

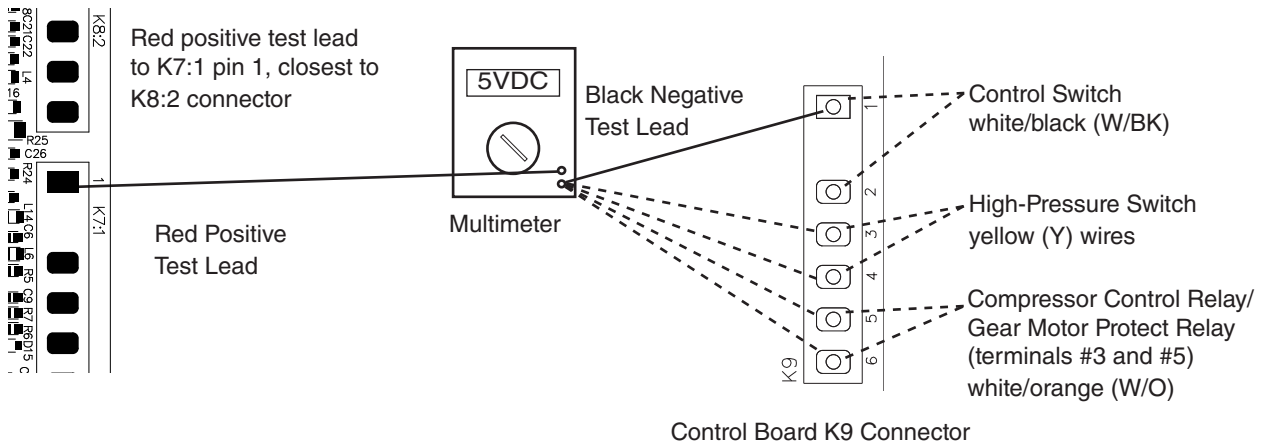

Fig. 3

- a) **Control Switch** – CB K9 #1 (W/BK) and CB K9 #2 (W/BK):
 5VDC is present between CB K7:1 red connector (open) pin 1, (closest to CB K8:2 white connector) and CB K9 #1 (W/BK) at all times. If 5VDC is not present, replace CB. When the control switch is in the "ICE" position, the control switch contacts are open. 0VDC is present between CB K7:1 red connector (open) pin 1, (closest to CB K8:2 white connector) and CB K9 #2 (W/BK). When in the "ICE" position, 5VDC is present between CB K9 #1 (W/BK) to CB K9 #2 (W/BK). When the control switch is in the "DRAIN" position, the control switch contacts are closed. 5VDC is present between CB K7:1 red connector (open) pin 1, (closest to CB K8:2 white connector), to CB K9 #1 (W/BK) or #2 (W/BK). If 5VDC is not present, replace CB. 0VDC is present from CB K9 #1 (W/BK) to CB K9 #2 (W/BK).
- b) **High-Pressure Switch** – CB K9 #3 (Y) and CB K9 #4 (Y):
 5VDC is present between CB K7:1 red connector (open) pin 1, (closest to CB K8:2 white connector) and CB K9 #3 (Y) at all times. When the high-pressure switch is closed, 5VDC is present between CB K7:1 red connector (open) pin 1, (closest to CB K8:2 white connector) to CB K9 #3 (Y) and CB K9 #4 (Y). If 5VDC is not present, replace CB. When the high-pressure switch is closed, 0VDC is present at CB K9 #3 (Y) to CB K9 #4 (Y). When the high-pressure switch is open, 5VDC is present at CB K9 #3 (Y) to CB K9 #4 (Y). If the high-pressure switch is open and CB is not in alarm, replace CB. If 5VDC is present at CB K9 #3 (Y) and not at CB K9 #4 (Y), the high-pressure switch is open and CB sounds a 3-beep alarm. Check continuity across the high-pressure switch (CB K9 #3 (Y) and CB K9 #4 (Y)).
- c) **Compressor Control Relay/Gear Motor Protect Relay (CCR/GMPR)** –
 CB K9 #5 (W/O) and CB K9 #6 (W/O): 5VDC is present from CB white K5 connector, pin closest to CB red K4 connector to CB K9 #5 (W/O) at all times. If 5VDC is not present, replace CB. When CCR/GMPR terminals #3 (W/O) and #5 (W/O) are open (CCR/GMPR de-energized), 5VDC is present between CB K9 #5 (W/O) and CB K9 #6 (W/O). When CCR/GMPR terminals #3 (W/O) and #5 (W/O) are closed (CCR/GMPR energized), 5VDC is present between CB K9 #5 (W/O) and CB K9 #6 (W/O). When CCR/GMPR terminals #3 (W/O) & #5 (W/O) are open CB may be in an 8-beep alarm. See "III.A.2. LED Lights and Audible Alarm Safeties."
- d) **Bin Control 2 (backup)** –
 CB K8 #3 (GY) and CB K8 #4 (GY): 5VDC is present from CB white K5 connector, pin closest to CB red K4 connector to CB K8 #3 (GY) at all times. If 5VDC is not present, replace CB. When BC(2) is closed (calling for ice), 5VDC is present from CB K7:1 red connector (open) pin 1, (closest to CB K8:2 white connector) to CB K8 #3 (GY) and CB K8 #4 (GY). If 5VDC is not present to either CB K8 #3 (GY) or CB K8 #4 (GY), replace CB. If 5VDC is present at CB K8 #3 (GY) and not to CB K8 #4 (GY), BC(2) is open. See "II.D.2. Bin Control (2) (mechanical stand-alone or backup) Check."
- e) **Float Switch (LFS and UFS)** – CB K8 #5 (BK) (common), CB K8 #6 (R) (upper), and CB K8 #7 (BU) (lower): 5VDC is present from CB K7:1 red connector (open) pin 1, (closest to CB K8:2 white connector) at all times. If not, replace CB. 5VDC is present from CB K7:1 red connector (open) pin 1, (closest to CB K8:2 white connector) to CB K8 #6 (R) (upper) and CB K8 #7 (BU) (lower) when FS is open. If 5VDC is present between CB K8 #5 (BK) and CB K8 #6 (R) (upper) or CB K8 #7 (BU) (lower), FS is open. For further FS diagnostics, see "II.E. Float Switch Check and Cleaning."

- 5) **Fill "WTRIN" LED is on:** 24VAC is present at CB K2 #9 (W/R) at all times. If not, confirm 24VAC from CB K2 #9 (W/R) to a neutral (LBU). When LFS open at startup or opens during normal operation, "WTRIN" LED turns on, fill timer (FT) starts, freeze timer (FZT) terminates (only during normal operation), and WV energizes. If LFS is open and "WTRIN" LED is off, confirm LFS status. See "II.E. Float Switch Check and Cleaning." If LFS is open and "WTRIN" LED is off, replace CB. If "WTRIN" LED is on and WV is not energized, check for 24VAC at CB K2 #8 (O) to a neutral (LBU). If 24VAC is not present at CB K2 #8 (O), replace CB. "WTRIN" LED turns off once UFS closes. If not, confirm UFS status. See "II.E. Float Switch Check and Cleaning." If UFS is closed and "WTRIN" LED is on, replace CB. If "WTRIN" LED is off and WV is open, check for 24VAC at CB K2 #8 (O). If 24VAC is present at CB K2 #8 (O), replace CB. If 24VAC is not present, check WV diaphragm.
- 6) **Ice Purge Cycle "GM" LED is on:** When UFS closes, GM delay timer starts (5 or 30 sec. depending on CB S2 dip switch #7). Once GM delay timer terminates, "GM" LED turns on, GM and EH (-C model except FD-650) energize and 5-min. ice purge timer starts. If GM does not energize 30 sec. after UFS closes, confirm UFS status. See "II.E. Float Switch Check and Cleaning." If UFS is closed and GM LED does not turn, replace CB. If "GM" LED is on and GM and EH are off, check for 115VAC from CB K1 #2 to a neutral (W). If 115VAC is not present, check 115VAC power supply connections from power switch. If 115VAC is present, check for 115VAC from CB K1 #3 to a neutral (W). If 115VAC is present on CB K1 #2 and not on CB K1 #3, replace CB.
- 7) **Freeze Cycle "GM" and "COMP" LED are on:** The 5-min. ice purge timer terminates or the ice purge cycle bypass button ("SERVICE") is pressed, "COMP" LED turns on. To bypass the 5-min. Ice Purge Cycle, press the "SERVICE" button on CB after the "GM" LED turns on. **WARNING! Risk of electric shock. Care should be taken not to touch live terminals.** 115VAC is present between CB X1 relay power supply brown (BR) or black (BK) wire and neutral (W) at all times. If not, check 115VAC power supply wire connections from power switch. If "COMP" LED is not on after 5-min. ice purge timer terminates, replace CB.
When "COMP" LED turns on, CR (if applicable) and compressor energize. If "COMP" LED is on and compressor relay (CR) (if applicable) and compressor are not, check for 115VAC from CB X1 relay power supply brown (BR) or black (BK) wire to neutral (W). If 115VAC is present, check X1 relay red (R), violet (V), or brown (BR) to neutral (W). If 115VAC is present on X1 relay brown (BR) or black (BK) and not on X1 relay red (R), violet (V), or brown (BR), replace CB.
- 8) **Refill "WTRIN" LED is on:** See "5) Fill "WTRIN" LED is on:" above.

Legend: **BC1**—bin control 1 (infrared/ultrasonic sensor); **BC2**—bin control 2 (backup);
CB—control board; **CR**—compressor relay; **CCR/GMPR**—compressor control relay/gear motor protect relay; **EH**—evaporator heater (-C model except FD-650);
FS—float switch; **GM**—gear motor; **LFS**—lower float switch; **UFS**—upper float switch;
WV—inlet water valve

Control Board

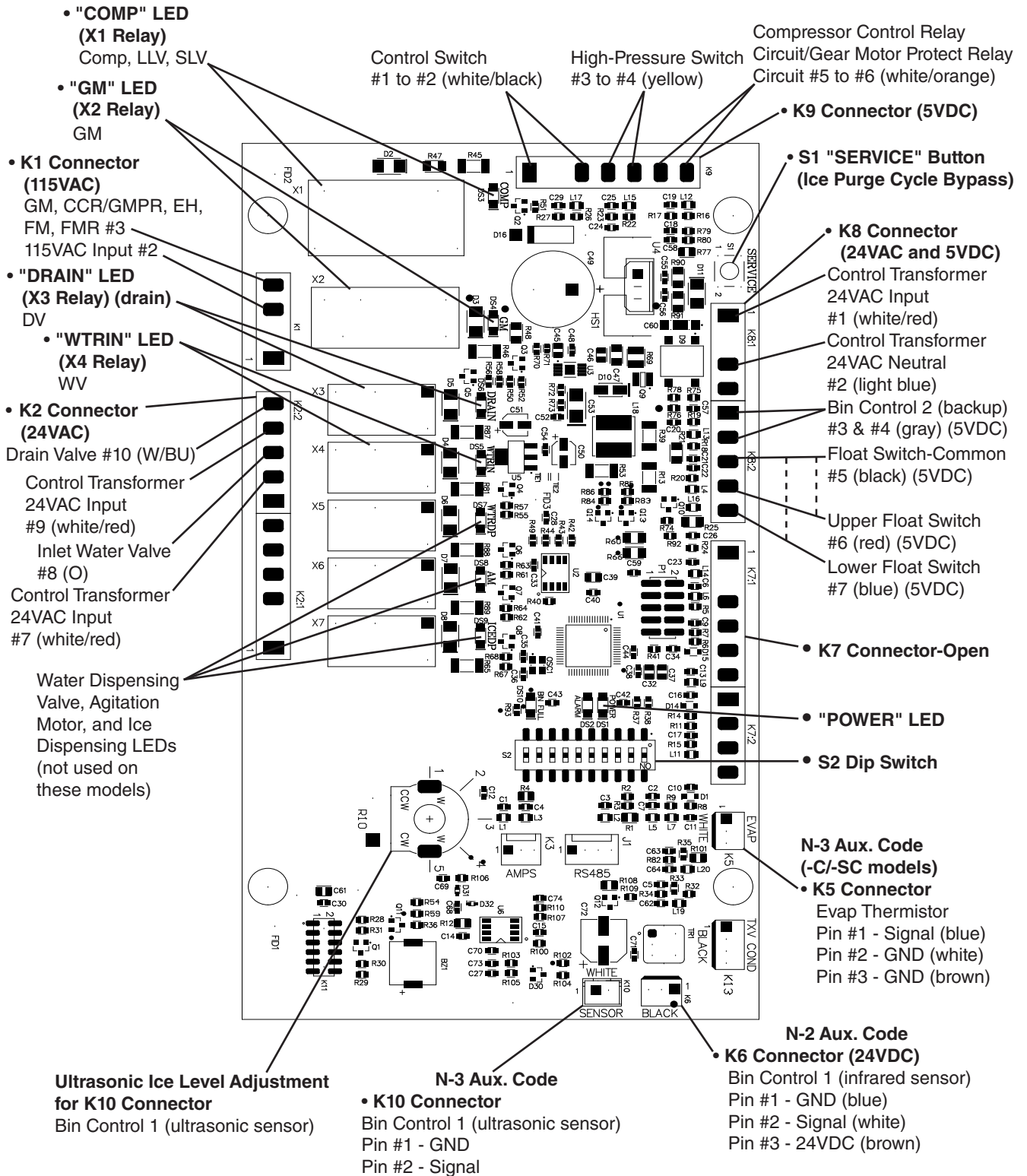

Control Board	
Part Number	2A9874-01

D. Bin Control Check and Adjustment

1a. N-2 Auxiliary Code - Bin Control 1 Check (infrared sensor)

IMPORTANT

Make sure CB S2 dip switch 7 is in the "ON" position. This allows the control board to monitor BC1 (infrared sensor) along with BC2 (mechanical) backup bin control.

- 1) Turn off the power supply.
- 2) Remove the front panel, top panel, and control box cover.
- 3) Confirm that CB S2 dip switch 1, 2, 3 are in the proper position for your application. See "III.B.2a. N-2 Auxiliary Code - BC1 (Infrared Sensor) Shutdown Delay (S2 dip switch 1, 2, 3)". CB S2 dip switch 1, 2, and 3 are used to adjust ice level.
- 4) Confirm that BC1 is connected to CB K6 connector. Wipe down BC1 lens with a warm, clean, damp cloth. If the bottom of the icemaker is not accessible in your application, remove the thumbscrew securing the BC1 housing, then remove the housing from the base. See Fig. 4.
- 5) Move the control switch to the "ICE" position, then move the power switch to the "ON" position.
- 6) Turn on the power supply to start the automatic icemaking process. Check that BC1 green LED is on. The BC1 green LED confirms 24VDC power from CB to BC1 and remains on constantly. **Diagnosis:** If the BC1 green LED is not on, confirm 24VDC at CB K6 #1 (DBU) to CB K6 #3 (BR). If 24VDC is present and the BC1 green LED is off, replace BC1. If not, see step "3a) BC1 (infrared sensor) Power Supply," under "II.C. Control Board Check.
- 7) Make sure CB "GM" LED is on. There is a delay of at least 30 sec. before the "GM" LED turns on after power-up. After CB "GM" LED turns on, press CB "SERVICE" button to bypass the 5-min. ice purge cycle. **WARNING! Risk of electric shock. Care should be taken not to touch live terminals.**

BC1 (infrared sensor)

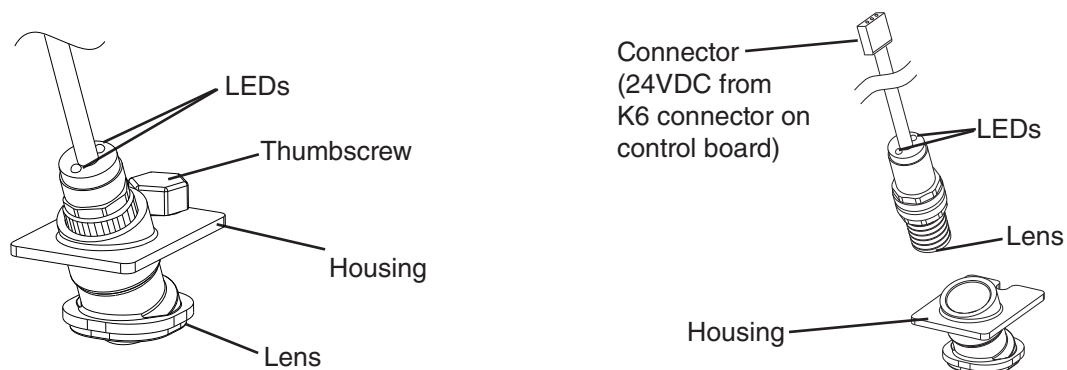

Fig. 4

8) CB "GM" and "COMP" LEDs are on. Use an object to cover BC1 lens at the bottom of the icemaker. If the bottom of the icemaker is not accessible in your application, remove the thumbscrew securing BC1 housing, remove the housing from the base, then cover BC1 lens. See Fig. 4. The orange LED on BC1 turns on (flashing or steady). The orange LED flashes when ice is at the outer limit of its range and turns steady as ice nears. After the orange LED turns on (flashing or steady), BC1 shutdown delay timer starts. See "III.B.2a. BC1 (Infrared Sensor) Shutdown Delay (S2 dip switch 1, 2, 3)." Comp (LLV/SLV on MLJ model) should de-energize immediately after the shutdown delay timer terminates. 5 min. later, GM and FM/FMR should de-energize.

Diagnosis: If BC1 orange LED is not on after covering the lens, replace BC1. If the appliance remains on after BC1 shutdown delay timer terminates and the 5-min. ice purge timer terminates, replace CB. If BC1 fails to shut down the icemaker and the level of ice activates BC2, the icemaker shuts down and a 9-beep alarm sounds. To reset, move the power switch to the "OFF" position, and then back to the "ON" position.

9) Remove the object covering the lens. If you removed BC1 housing from the base, replace it in its correct position, and secure it with the thumbscrew.

10) Move the power switch to the "OFF" position. Turn off the power supply, then proceed to "II.D.3. Bin Control 2 Check (backup)".

Legend: **BC1**—bin control 1 (infrared sensor); **BC2**—bin control 2 (backup); **CB**—control board; **Comp**—compressor; **FM**—fan motor; **FMR**—fan motor-remote; **GM**—gear motor; **LLV**—liquid line valve; **SLV**—suction line valve

1b. N-3 Auxiliary Code and Later - Bin Control 1 Check (ultrasonic sensor)

IMPORTANT

Make sure CB S2 dip switch 7 is in the "ON" position. This allows the control board to monitor BC1 (ultrasonic sensor) along with BC2 (mechanical) backup bin control.

- 1) Turn off the power supply.
- 2) Remove the front panel, top panel, and control box cover.
- 3) See "III.B.2b. N-3 Auxiliary Codes and later - BC1 (Ultrasonic Sensor) Shutdown Delay (S2 dip switch 1, 2, 3)."
- 4) Confirm that BC1 is connected to CB K10 connector. Wipe down BC1 lens with a warm, clean, damp cloth. If the bottom of the icemaker is not accessible in your application, remove the thumbscrew securing the BC1 housing, then remove the housing from the base. See Fig. 5.
- 5) Move the control switch to the "ICE" position, then move the power switch to the "ON" position.
- 6) Turn on the power supply to start the automatic icemaking process. Check that CB BC1 orange "BIN FULL" LED is off. **Diagnosis:** If the CB BC1 orange "BIN FULL" LED is on, move ice away from lens. If no ice is present, clean the lens with a warm, clean damp cloth. If cleaning the lens does not work, replace BC1 (ultrasonic sensor). See step "3b) BC1 (ultrasonic sensor) Power Supply," under "II.C. Control Board Check."
- 7) Make sure CB "GM" LED is on. There is a delay of at least 30 sec. before the "GM" LED turns on after power-up. After CB "GM" LED turns on, press CB "SERVICE" button to bypass the 5-min. ice purge cycle. **WARNING! Risk of electric shock. Care should be taken not to touch live terminals.**

BC1 (ultrasonic sensor)

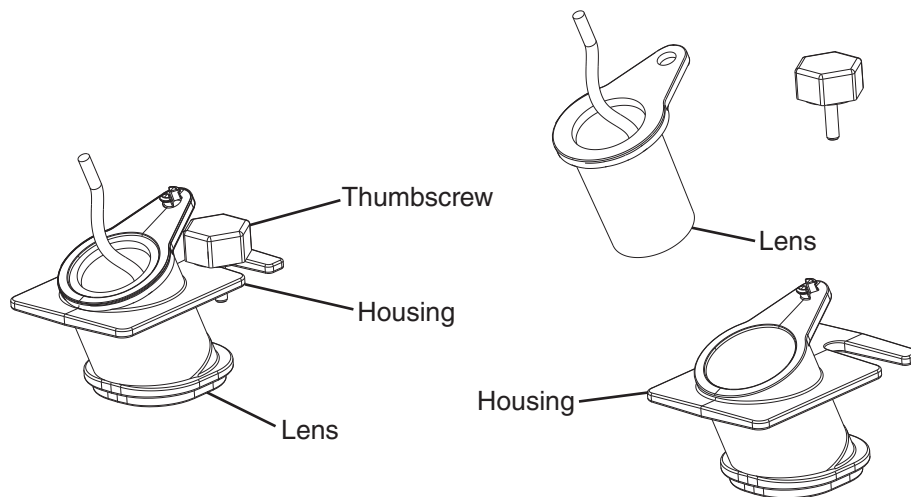

Fig. 5

8) CB "GM" and "COMP" LEDs are on. Use an object to cover BC1 lens at the bottom of the icemaker. If the bottom of the icemaker is not accessible in your application, remove the thumbscrew securing BC1 housing, remove the housing from the base, then cover BC1 lens. See Fig. 5. The CB BC1 "BIN FULL" orange LED on turns on. After the orange LED turns on, BC1 shutdown delay timer starts. See "III.B.2b. BC1 (Ultrasonic Sensor) Shutdown Delay (S2 dip switch 1, 2, 3)." Comp (LLV/SLV on MLJ model) should de-energize immediately after the shutdown delay timer terminates. 5 min. later, GM and FM/FMR should de-energize.

Diagnosis: If CB BC1 "BIN FULL" orange LED is not on after covering the lens, replace BC1. If the appliance remains on after BC1 shutdown delay timer terminates and the 5-min. ice purge timer terminates, replace CB. If BC1 fails to shut down the icemaker and the level of ice activates BC2, the icemaker shuts down and a 9-beep alarm sounds. To reset, move the power switch to the "OFF" position, and then back to the "ON" position.

9) Remove the object covering the lens. If you removed BC1 housing from the base, replace it in its correct position, and secure it with the thumbscrew.

10) Move the power switch to the "OFF" position. Turn off the power supply, then proceed to "II.D.3. Bin Control 2 Check (backup)".

Legend: **BC1**—bin control 1 (ultrasonic sensor); **BC2**—bin control 2 (backup); **CB**—control board; **Comp**—compressor; **FM**—fan motor; **FMR**—fan motor-remote; **GM**—gear motor; **LLV**—liquid line valve; **SLV**—suction line valve

2. N-3 Auxiliary Code and Later - Bin Control 1 Adjustment (ultrasonic sensor)

⚠ WARNING

- Improper adjustment may adversely affect safety, performance, component life, and warranty coverage.
- On dispenser unit applications, do not increase ice level above the recommended setting listed below. Higher ice levels could result in icemaker movement, water leakage, or ice overflow.

NOTICE

Do not allow top kits or top kit risers (if applicable) to interfere with the bin control lens sensing area or the icemaker will not operate properly.

- 1) Move the power switch to the "OFF" position. Make sure the power supply is off to the icemaker and condensing unit. Remove the front panel to access the control box assembly. See Fig. 6. Remove the control box cover to access the control board. See Fig. 7.

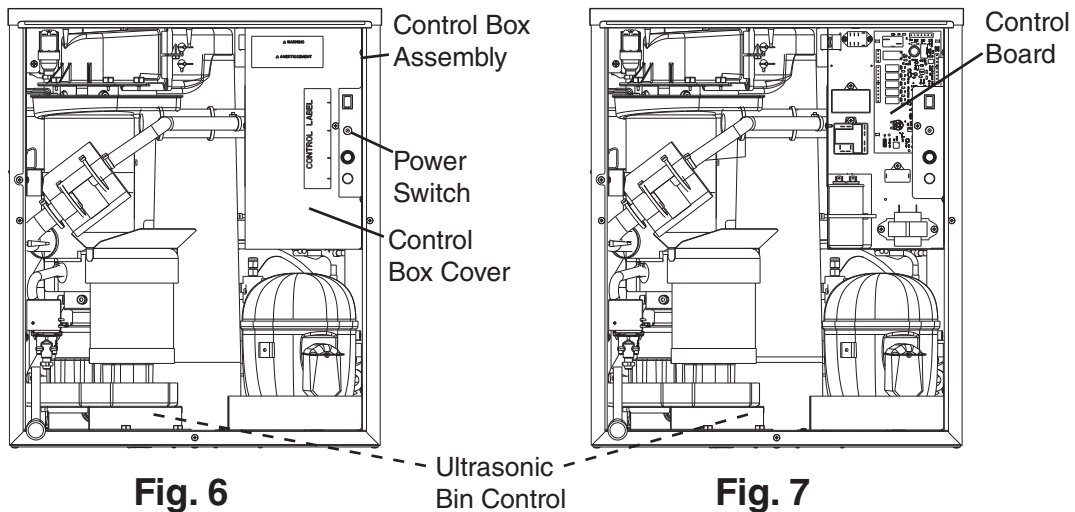

- 2) Confirm the correct control board bin control setting required for your application and adjust according to the following tables. See Fig. 8 and Fig. 9.

For Standard Ice Storage Bins, and Coca-Cola Freestyle® Dispenser Units

Application	Bin Control Ice Level Settings	
	Bin Control Setting	Shutdown Distance From Ultrasonic Bin Control Lens (Restart is 4 in. (102 mm) below shutdown distance)
Standard Ice Storage Bins	1 (Factory Default)	127 mm (5") Do not adjust dispensers to this setting.
Coca-Cola Freestyle® Dispensers	3	254 mm (10")
Optional Setting	4	356 mm (14")
	5	457 mm (18")

⚠ WARNING

Confirm that the final ice level location does not allow for icemaker movement, water leakage, or ice overflow.

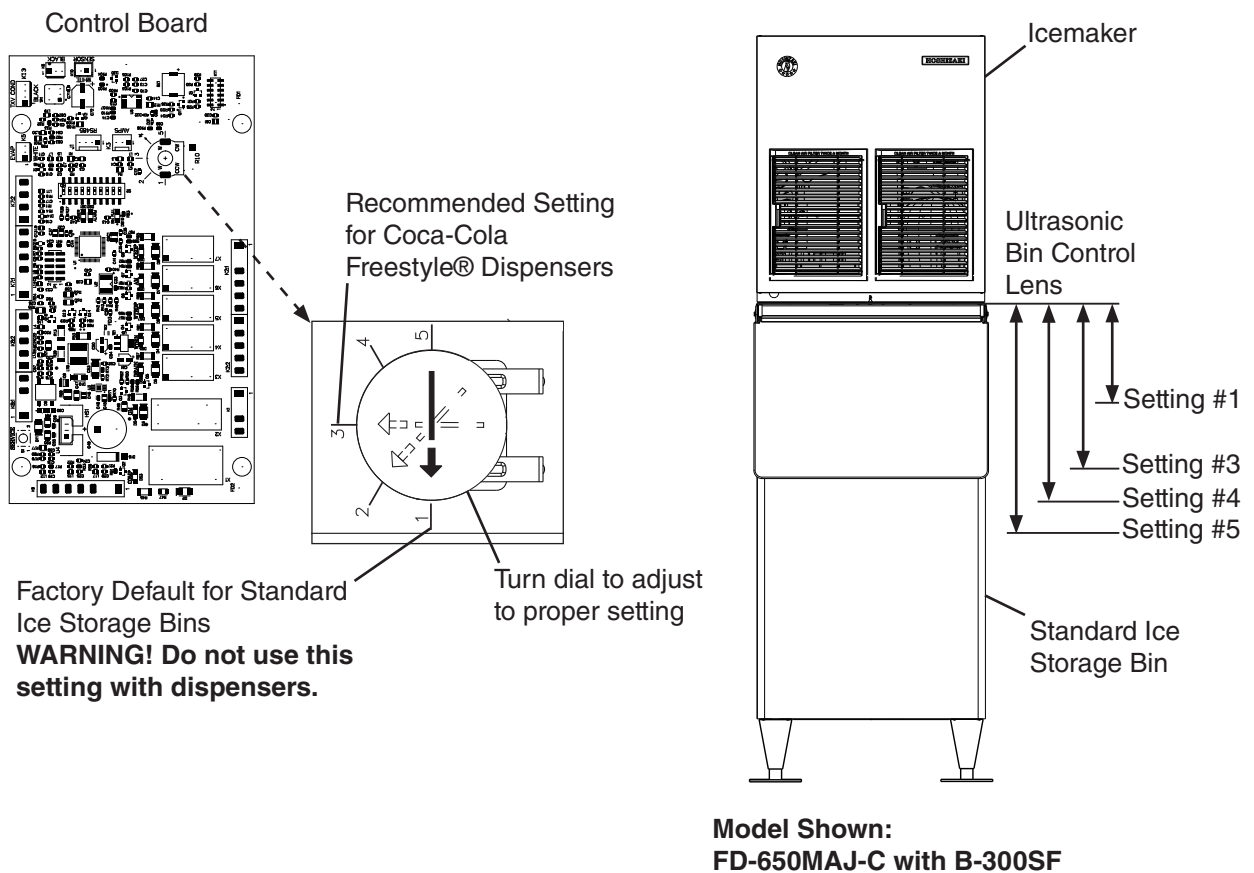

Fig. 8

For Non-Hoshizaki Dispenser Units

Bin Control Ice Level Settings	
Bin Control Setting	Shutdown Distance From Bin Control Lens (Restart is 4 in. (102 mm) below shutdown distance)
1 (Factory Default)	127 mm (5") Do not adjust dispensers to this setting.
2	178 mm (7")
3	254 mm (10")
4	356 mm (14")
5	457 mm (18")

⚠ WARNING

Confirm that the final ice level location does not allow for icemaker movement, water leakage, or ice overflow.

NOTICE

The ice level must be lower than the top of the dispenser unit. Also, be sure the top kit or top kit riser (if applicable) are clear from the bin control lens sensing area.

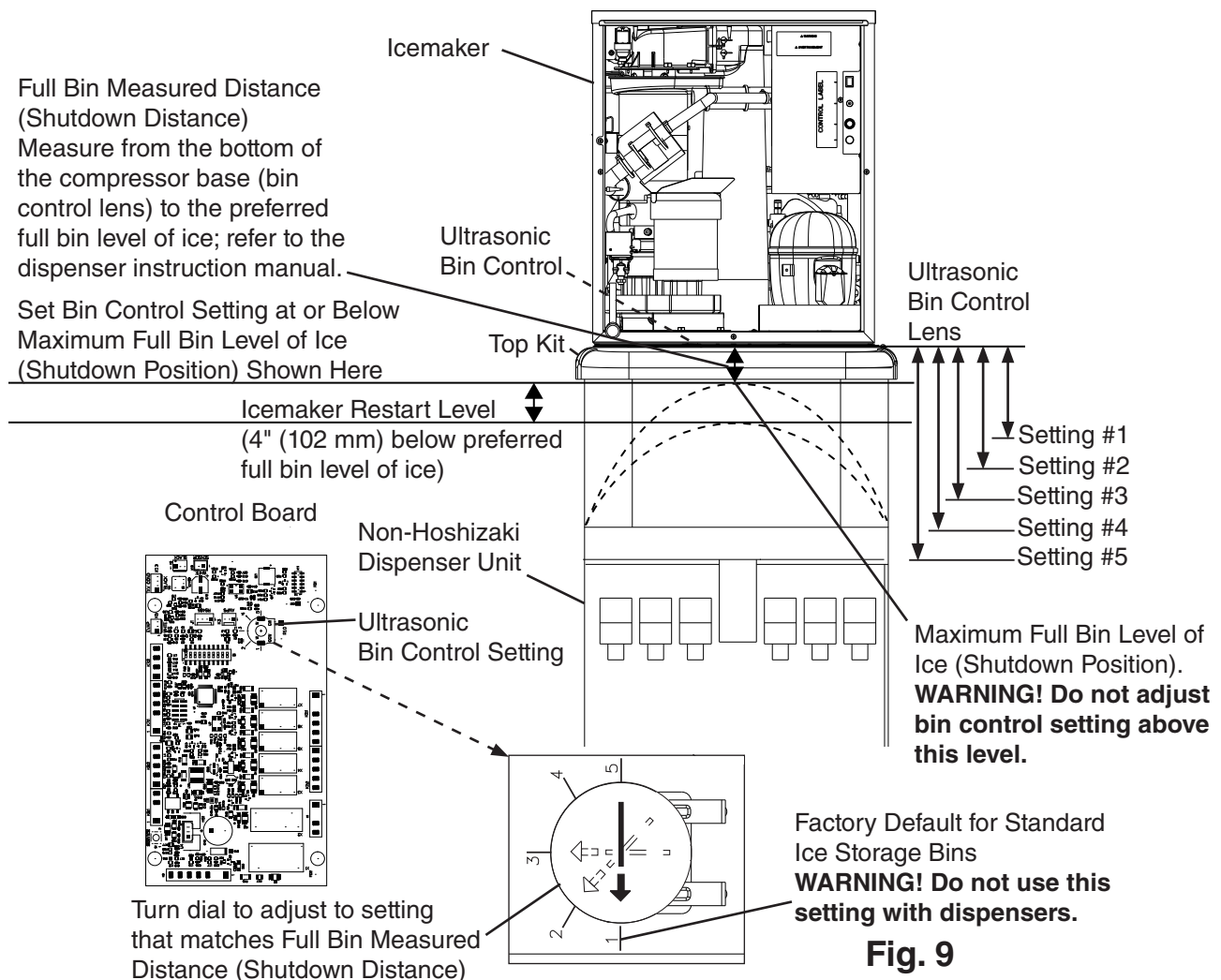

3. Bin Control 2 Check (backup)

When the actuator paddle is not engaged BC2 is closed and the icemaker produces ice.

a) Bin Control 2 (Mechanical Backup): With CB S2 dip switch 7 placed in the "ON" position, BC2 is used as a backup bin control safety. When ice fills the chute and engages the actuator paddle, BC2 opens and CB shuts down the icemaker immediately and sounds a 9-beep alarm.

- 1) Make sure the power supply is off. Remove the front panel, top panel, and control box cover.
- 2) Remove the spout-to-chute strap connecting the spout to the chute assembly. See Fig. 10. Pull up the chute assembly slightly so that you can access the actuator paddle located in the top of the chute.

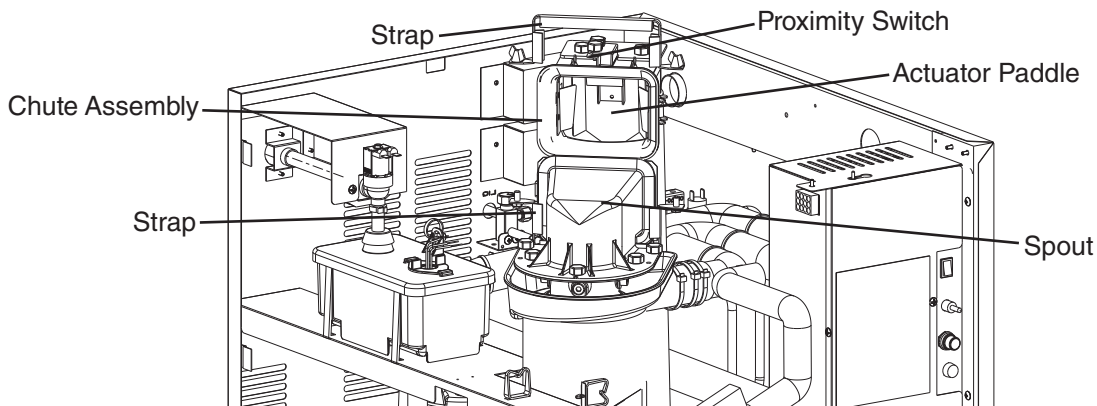

Model Shown: F-1002MRJZ

Fig. 10

- 3) Move the power switch to the "ON" position.
- 4) Turn on the power supply to start the automatic icemaking process.
- 5) Make sure CB "GM" LED is on. There is a delay of at least 30 sec. before "GM" LED turns on after power-up. After "GM" LED turns on, press CB "SERVICE" button to bypass the 5-min. compressor delay. **WARNING! Risk of electric shock. Care should be taken not to touch live terminals.** The "COMP" LED turns on.

6) Press the actuator paddle located in the top of the chute. Comp (LLV and SLV on MLJ model) and GM de-energize within 10 sec.

Diagnosis: If BC2 does not open and the icemaker continues to make ice (mechanical stand-alone or backup), CB fails to shutdown icemaker within 10 sec. or go into alarm, check that the actuator paddle is engaged. Check for continuity across BC2 wires. If BC2 contacts are found open and the icemaker continues to make ice or CB fails to go into alarm (BC2), replace CB. If BC2 is closed with the actuator paddle engaged, replace BC2.

WARNING! If dip switch 9 is in the "OFF" position, the shut down delay is too long. This could lead to icemaker movement or ice overflow.

7) Move the power switch to the "OFF" position and turn off the power supply.

8) Replace the chute assembly and strap in their correct positions.

9) Move the power switch to the "ON" position.

10) Replace the control box cover, top panel, and front panel in their correct positions.

11) Turn on the power supply to start the automatic icemaking process.

Legend: **BC1**—bin control 1 (infrared/ultrasonic sensor); **BC2**—bin control 2 (backup);
CB—control board; **Comp**—compressor; **FM**—fan motor; **FMR**—fan motor-remote;
GM—gear motor; **LLV**—liquid line valve; **SLV**—suction line valve

E. Float Switch Check and Cleaning

1. Float Switch Check

A dual float switch is used to determine that there is sufficient water in the reservoir during fill and refill. CB monitors UFS to de-energize WV when UFS closes during fill and refill. CB monitors LFS to energize WV when LFS opens during the freeze cycle (refill). CB monitors the time between LFS opening and UFS closing (90-sec. low water safety). CB also monitors the time between UFS closing and LFS opening (30-min. freeze timer). No adjustment is required.

- 1) Remove the front panel and move the power switch to the "OFF" position. Move the control switch to the "DRAIN" position.
- 2) Move the power switch to the "ON" position.
- 3) Allow the water to drain from the reservoir, then move the power switch to the "OFF" position and the control switch to the "ICE" position.
- 4) Disconnect the molex plug from the control box and check continuity across FS wires. (BK) to (R) for UFS and (BK) to (BU) for LFS. See Fig. 11. With the water reservoir empty, FS switches are open. If open, continue to step 5. If closed, follow the steps in "II.E.2. Float Switch Cleaning." After cleaning the floats, check them again. Replace if necessary.
- 5) Reconnect the molex plug on the control box.
- 6) Move the power switch to the "ON" position and let the water reservoir fill.
- 7) Once the reservoir is full and GM starts, move the power switch to the "OFF" position.
- 8) Disconnect the molex plug from the control box and check continuity across FS wires. (BK) to (R) for UFS and (BK) to (BU) for LFS. They should be closed. Clean or replace if necessary.

Fig. 11

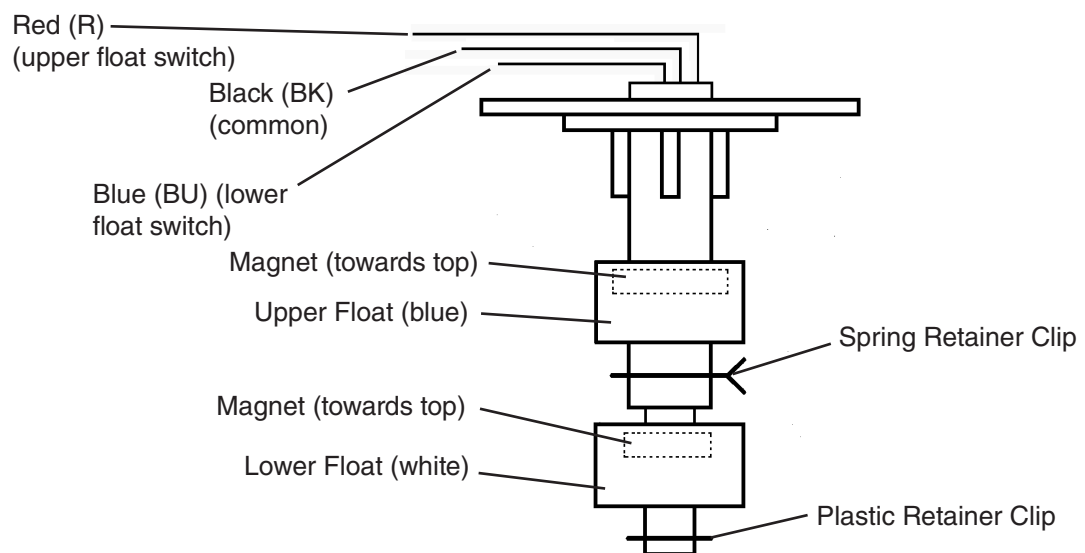

2. Float Switch Cleaning

Depending on local water conditions, scale may build up on FS. Scale on FS can cause the floats to stick. In this case, FS should be cleaned and checked.

- 1) Turn off the power supply.
- 2) Remove the float switch assembly from the reservoir cover. See Fig. 12.
- 3) Wipe down FS assembly with a mixture of 1 part Hoshizaki "Scale Away" and 25 parts warm water.
- 4) While not necessary, the floats can be removed from the shaft during cleaning. If you remove them, note that the blue float is on top. The floats must be installed with the magnets inside them towards the top of the switch. See Fig. 6. Installing the floats upside down will affect the timing of FS operation.
- 5) Rinse FS assembly thoroughly with clean water and replace in its original position.

Legend: **CB**—control board; **FS**—float switch; **GM**—gear motor; **LFS**—lower float switch; **UFS**—upper float switch; **WV**—inlet water valve

Fig. 12

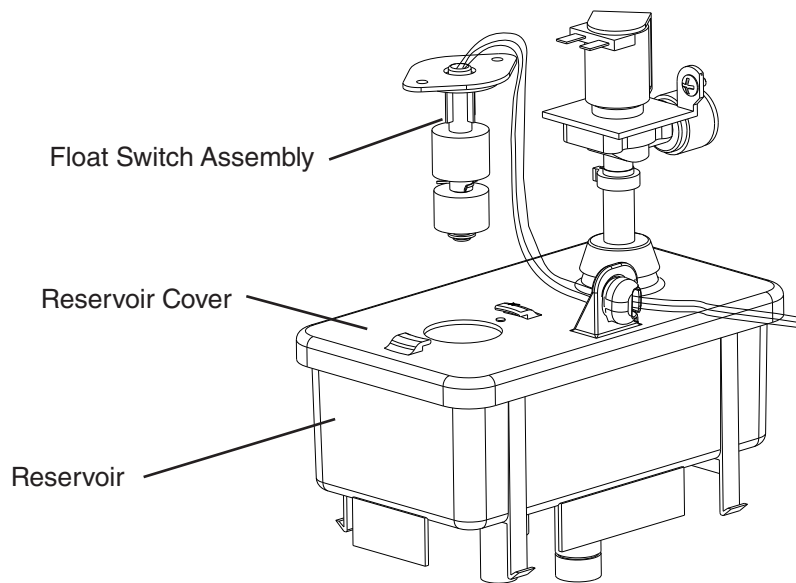

F. Diagnostic Tables

Before consulting the diagnostic charts, check for correct installation, proper voltage per appliance nameplate, and adequate water supply. Check control board using the steps in "II.C. Control Board Check."

1. No Ice Production

No Ice Production - Possible Cause	
Startup	
1. Power Supply	a) Off, blown fuse, or tripped breaker. b) Loose connection. c) Bad contacts. d) Not within specifications.
2. Water Supply	a) Water supply off or pressure too low.
3. Power Switch (Control Box)	a) "OFF" position. b) Bad contacts.
4. Control Transformer	a) Coil winding opened.
5. Fuse (Control Box)	a) Blown.
6. BC1 (Infrared Sensor)	a) No power or defective.
BC1 (Ultrasonic Sensor)	a) Defective.
7. BC2 (Backup)	a) Tripped with bin filled with ice. (9-beep alarm when used in conjunction with BC1 (infrared sensor)) b) Switch stuck open. c) Actuator paddle does not move freely.
8. High-Pressure Switch	a) Bad Contacts. b) Dirty air filter or condenser. c) Ambient or condenser water temperature too warm. d) Refrigerant overcharged. e) Fan not operating (except water-cooled model). f) Refrigerant line or component restricted. g) Condenser water pressure too low or off (water-cooled model). h) Water regulating valve set too high (water-cooled model).
9. Control Switch	a) "DRAIN" position. 2-beep alarm if in "DRAIN" position for more than 15 min. b) Bad contacts.
Fill Cycle	
1. Control Board	a) No Power to inlet water valve. b) No power to float switch or not reading float switch condition.
2. Inlet Water Valve	a) Screen or orifice clogged. b) Coil winding opened.
3. Float Switch	a) Float does not move freely. b) Defective.
4. Drain Water Valve	a) Valve seat clogged and water leaking.
5. Hoses	a) Disconnected.

Ice Purge Cycle	
1. Control Board	a) No power to gear motor.
	b) No power to compressor control relay.
2. Gear Motor	a) Blown fuse.
	b) Internal protector open.
	c) Defective.
Freeze Cycle	
1. Compressor Control Relay	a) No voltage from gear motor.
	b) Defective.
2. Control Board	a) Defective.
3. Start Relay	a) Bad contacts.
	b) Coil winding opened.
	c) Loose connections.
4. Capacitor (start or run)	a) Defective, weak.
5. Power Supply	a) Not within specifications.
6. Refrigerant Line	a) Gas leaks.
	b) Refrigerant line or component restricted.
7. Thermostatic Expansion Valve (TXV) (not adjustable)	a) Defective.
8. Compressor	a) Defective.
9. Liquid Line Valve (MLJ models)	a) Defective.
10. Suction Line Valve (MLJ models)	a) Defective.
11. Fan Motor (if applicable)	a) Compressor Control Relay/Magnetic Contactor defective.
	b) Defective capacitor.
	c) Defective.
	d) Control board defective.
12. Evaporator	a) Dirty.
	b) Damaged or defective.
13. Headmaster (C.P.R.) (remote air-cooled model)	a) Not operating properly and liquid line temperature too warm.
14. Water Supply Line (water-cooled model)	a) Condenser water pressure too low or off and high pressure control opens and closes frequently.
15. Water Regulating Valve (water-cooled model)	a) Set too high.
16. Magnetic Contactor (if applicable)	a) Defective.
17. Drain Valve	a) Dirty, leaking by.
	b) Defective.
18. Water System	a) Water leaks.

Refill	
1. Float Switch	a) Dirty/sticking.
	b) Defective.
2. Inlet Water Valve	a) Clogged or defective.
3. Water Supply	a) Off.
4. Control Board	a) No power to float switch or not reading float switch condition.
	b) No power to inlet water valve.
Shutdown	
1. BC1 (Infrared Sensor) See "II.D. 1a. Bin Control Check."	a) Dirty Infrared lens.
	b) Defective.
BC1 (Ultrasonic Sensor) See "II.D. 1b. Bin Control Check."	a) Dirty Bin Control lens.
	b) Defective.
2. BC2 (Backup) See "II.D. Bin Control Check."	a) Actuator paddle does not move freely.
	b) Defective.
3. Control Board	a) Control board dip switches set incorrectly.
	b) In alarm.
	c) Defective.
Drain Cycle	
1. Drain Valve	a) Screen or orifice clogged.
	b) Defective.
2. Control Board	a) Defective.

III. Controls and Adjustments

A. Control Board

- A Hoshizaki exclusive control board is employed.
- All models are pretested and factory adjusted.
- For a control board check procedure, see "II.C. Control Board Check."

NOTICE

- Fragile, handle very carefully.
- The control board contains integrated circuits, which are susceptible to failure due to static discharge. It is especially important to touch the metal part of the icemaker when handling or replacing the control board.
- Do not touch the electronic devices on the control board or the back of the control board.
- Do not change wiring and connections. Do not misconnect terminals.
- Do not short out power supply to test for voltage.
- Always replace the whole control board assembly if it goes bad.

1. Control Board Layout

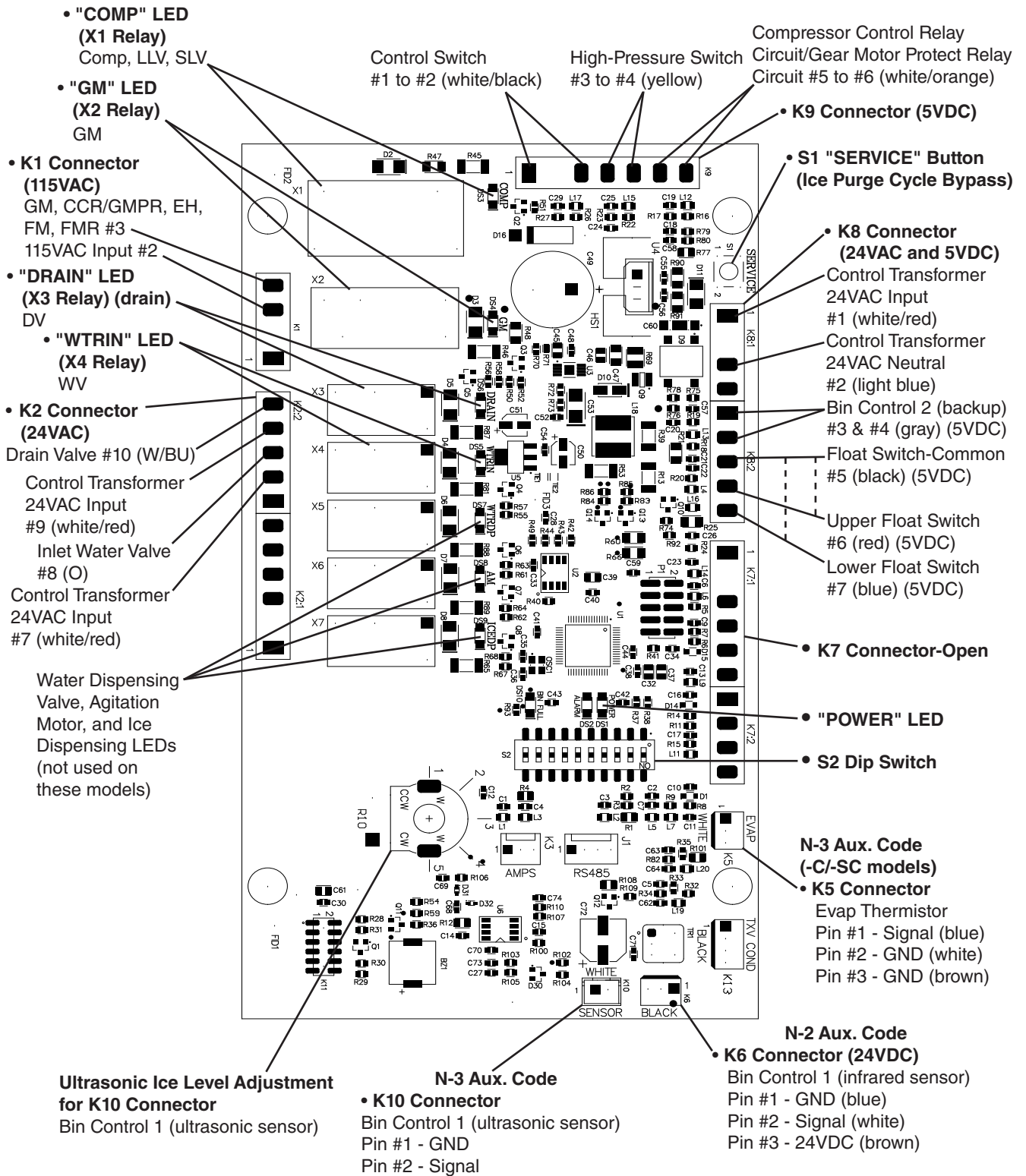

Control Board	
Part Number	2A9874-01

2. LED Lights and Audible Alarm Safeties

The "POWER" LED indicates proper control voltage and will remain on unless a control voltage problem occurs. For further details, see "II.A. Sequence of Operation Flow Chart."

Sequence Step	LED	Energized Components	Min.	Max.
Fill Cycle	WTRIN	WV	-	-
Ice Purge Cycle	GM	GM, EH, FM/FMR	5 min.	5 min.
Freeze Cycle (with refill)	GM, WTRIN* (refill), COMP	GM, EH, Comp, FM/FMR, LLV, SLV, WV* (refill)	-	*On until UFS closes. Alarm sounds after 90 sec.
Drain Cycle 1-in-1 hr. or 1-in-12 hr.	DRAIN	1-in-1 hr: DV 1-in-12 hr: DV (Icemaker status does not change)	2 sec. (1-in-1 hr.)	10 min. (1-in-12 hr.)

In case of alarm, the built-in alarm safeties shut down the unit, the orange "ALARM" LED turns on, and audible alarms sound as listed below.

No. of Beeps (every 5 sec.)	Type of Alarm	Notes and Reset Options
1	Low-Water Safety UFS open > 90 sec. after WV energized.	Automatic reset once water supply is restored and UFS closes.
2	Control Switch In "DRAIN" position longer than 15 min.	Automatic reset once the control switch is moved to the "ICE" position.
3	High-Pressure Switch First and second activation in 1 hr.	Automatic reset once pressure drops below the high pressure threshold and the high-pressure switch closes.
4	High-Pressure Switch Third activation in 1 hr.	Turn power off. Call for service. To avoid possible catastrophic failure, it is recommended to leave the icemaker off until this alarm is resolved.
5	Freeze Timer WV off > 30 min. since last WV activation.	Call for service. Manual reset. Turn power off and on again. Check for FS stuck (up), WV leaking by, TXV defective, LLV not opening, low charge, HM not bypassing, or inefficient Comp.
6	Low Voltage 92VAC ± 5% or less.	Green "POWER" LED turns off if voltage protection operates.
7	High Voltage 147VAC ± 5% or more.	Control voltage safeties automatically reset when voltage is corrected.
8	a) Gear Motor Fuse or Protector Open CCR contacts fail to close. Used on all models.	Turn power off. Check for GM fuse or protector open. Replace fuse or let protector cool and reset. If persistent trips occur, call for service.
	b) Evaporator Thermistor At GM startup Evaporator thermistor < -4°F (-20°C). Used on cubelet (-C)(-SC)(-CB) models only.	Turn power off. Call for service. To avoid possible catastrophic failure, it is recommended to leave the icemaker off until this alarm is resolved. Manual reset. Turn power off and on again.
9	Bin Control 2 (Mechanical) Open Circuit Control Board K8 (#3 and #4) Not used on DCM or self-contained models.	Manual reset. Turn power off and on again. Modular Flaker and Cubelet (-C)(-SC)(-CB) Models: Control Board S2 Dip Switch #7 must be ON. DCM and Self-Contained Models: Control Board S2 Dip Switch #7 must be OFF.
10	Evaporator Thermistor Evaporator thermistor reaches -22°F (-30°C) for 3 consecutive cycles. Used on cubelet (-C)(-SC)(-CB) models only.	Turn power off. Call for service. To avoid possible catastrophic failure, it is recommended to leave the icemaker off until this alarm is resolved. Manual reset. Turn power off and on again.

Legend: **CCR**—compressor control relay; **Comp**—compressor; **DV**—drain valve; **EH**—evaporator heater; **FM**—fan motor; **FMR**—fan motor-remote; **FS**—float switch; **GM**—gear motor; **HM**—headmaster (C.P.R.); **LLV**—liquid line valve; **SLV**—suction line valve; **TXV**—thermostatic expansion valve; **UFS**—upper float switch; **WV**—inlet water valve

3. Ice Purge Cycle Bypass

To speed up the diagnostic process, the 5-min. ice purge cycle may be bypassed by pressing the "SERVICE" button on the control board after the gear motor starts.

WARNING! Risk of electric shock. Care should be taken not to touch live terminals.

B. Controls and Adjustments

NOTICE

Dip switches are factory set. Failure to maintain factory settings may adversely affect performance and warranty coverage. For more information, contact your Hoshizaki Certified Service Representative.

1. Default Dip Switch Settings

The S2 dip switch settings are factory-set to the following positions:

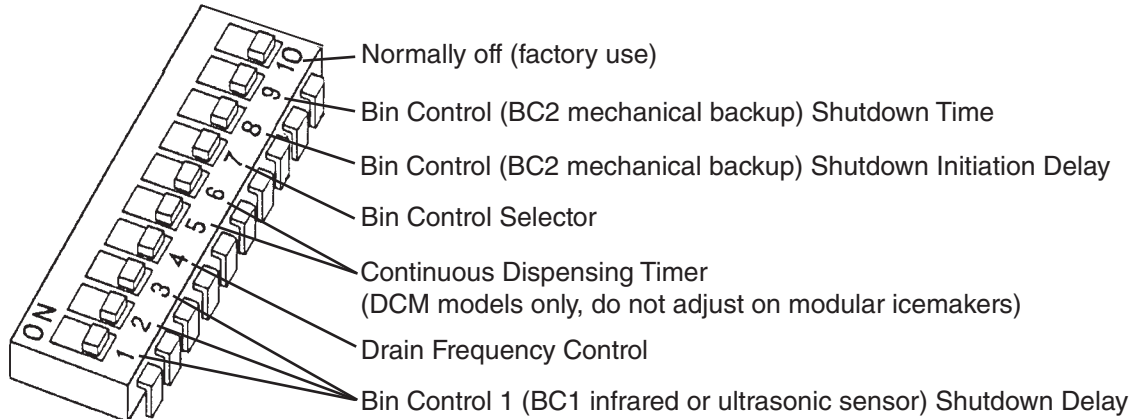

Control Board	Dip Switch No.	1	2	3	4	5	6	7	8	9	10
2A9874-01 (BC1 and BC2)	F-450MAJ(-C) F-801M_J(-C) F-1002M_J(Z)(-C)(-SC) FD-1002M_J(Z)(-C)(-CB) FD-650M_J(Z)-C	ON	OFF	OFF	OFF	OFF	OFF	ON	ON	OFF	OFF

2a. N-2 Auxiliary Code -

BC1 (Infrared Sensor) Shutdown Delay (S2 dip switch 1, 2, 3)

Infrared sensor shutdown delay is the delay between the infrared sensor detecting ice (infrared sensor orange LED flashing or steady and CB "BIN FULL" orange LED on) and the start of the shutdown sequence. For dispenser unit applications, the ice level at shutoff may need to be adjusted depending on the dispenser agitation or dispense method. Increasing the shutdown delay setting allows for a higher level of ice in the bin before the icemaker shuts down. For a typical dispenser unit application, a 100-sec. shutdown delay is recommended. When used with a standard Hoshizaki ice storage bin, any shutdown delay setting is acceptable. **WARNING! Increasing the shutdown delay allows a higher level of ice in the dispenser unit/ice storage bin before shutdown. This could lead to icemaker movement or ice overflow.**

S2 Dip Switch Setting			Infrared Sensor Shutdown Delay
No. 1	No. 2	No. 3	
OFF	OFF	OFF	0 Seconds
ON	OFF	OFF	100 Seconds (1.7 minutes) (Factory Default)
OFF	ON	OFF	1100 Seconds (18.3 minutes)
OFF	OFF	ON	1650 Seconds (27.5 minutes)
ON	ON	OFF	2200 Seconds (36.7 minutes)
OFF	ON	ON	0 Seconds
ON	ON	ON	0 Seconds

2b. N-3 Auxiliary Codes and later -

BC1 (Ultrasonic Sensor) Shutdown Delay (S2 dip switch 1, 2, 3)

Ultrasonic sensor shutdown delay is the delay between the ultrasonic sensor detecting ice (CB "BIN FULL" orange LED on) and the start of the shutdown sequence.

Note: For ice level adjustment, reference the Instruction Manual for this appliance.

S2 Dip Switch Setting			Ultrasonic Sensor Shutdown Delay
No. 1	No. 2	No. 3	
OFF	OFF	OFF	30 seconds
ON	OFF	OFF	
OFF	ON	OFF	
OFF	OFF	ON	
ON	ON	OFF	
OFF	ON	ON	
ON	ON	ON	

3. Drain Frequency Control (S2 dip switch 4)

This appliance is factory set for optimum performance with the 1-in-1 drain cycle (S2 dip switch 4 in the off position). This setting allows for removal of sediment from the evaporator without interrupting the icemaking process. An optional 1-in-12 drain cycle is available.

S2 Dip Switch Setting	Drain Timer Interval	Drain Valve Open
No. 4		
OFF (1-in-1)	1 Hour	2 Seconds
ON (1-in-12)	11 Hours 45 Minutes	10 Minutes

4. Continuous Dispensing Timer (S2 dip switch 5 & 6)

DCM models only. The dispense mode switch on DCMs must be in the "CONTINUOUS" position for this setting to apply. The factory setting allows ice to be dispensed continuously as long as the dispense solenoid is activated.

S2 Dip Switch Setting		Dispense Time
No. 5	No. 6	
OFF	OFF	No Limit
ON	OFF	20 Seconds
OFF	ON	60 Seconds
ON	ON	No Limit

5. Bin Control Selector (S2 dip switch 7)

The bin control is factory set. No adjustment required. **WARNING! Do not place S2 dip switch 7 in the "OFF" position on dispenser unit applications. This could lead to icemaker movement or ice overflow.**

S2 Dip Switch Setting	Bin Control Application	Gear Motor Delay
No. 7		
OFF	BC2 (mechanical stand-alone) (Standard Ice Storage Bins Only) Use for emergency use only, if needed.	5 seconds
ON	BC1 (infrared sensor or ultrasonic sensor) Stand-Alone with BC2 (backup)	30 seconds

6. BC2 (Mech. Backup) Shutdown Initiation Delay (S2 dip switch 8)

Only available when S2 dip switch 7 is in the "OFF" position. Factory set for normal operation. No adjustment is required. The shutdown initiation delay is the time between the mechanical bin control opening and dip switch 9 timer starting.

S2 Dip Switch Setting	Shutdown Delay
No. 8	
OFF	0.25 Seconds
ON	6.7 Seconds

7. BC2 (Mech. Backup) Shutdown Time (S2 Dip Switch 9)

Only available when S2 dip switch 7 is in the "OFF" position. Factory set for optimum performance. Do not adjust. Dip switch 9 shutdown timing starts when Dip Switch 8 timer terminates.

S2 Dip Switch Setting	Shutdown Sequence
No. 9	
OFF	Slow timing (90s after dip switch 8 timer terminates, the COMP shuts down; 60 sec. later, the GM shuts down)
ON	Fast timing (immediate)(after dip switch 8 timer terminates, both COMP & GM shuts down at the same time)

8. Factory Use (S2 Dip Switch 10)

Factory set for optimum performance. Do not adjust.

C. Power Switch and Control Switch

The power switch and the control switch are used to control the icemaker. They are located on the control box.

1. Power Switch

The power switch has 2 positions, "OFF" and "ON." When the power switch is in the "OFF" position, no power is supplied to the components. When in the "ON" position, power is supplied to the control transformer and control board. The control board then supplies 5VDC to the control switch for unit operation.

2. Control Switch

The control switch has 2 positions, "ICE" and "DRAIN."

When the control switch is in the "ICE" position (open), icemaking begins.

When the control switch is in the "DRAIN" position (closed), the drain valve energizes.

a) ICE

When the control switch is in the "ICE" position, the control board reads an open circuit through the control switch contacts and starts the icemaking process.

b) DRAIN

When the control switch is in the "DRAIN" position, the control board reads a closed circuit through the control switch and the drain valve energizes. See "IV. Refrigeration Circuit and Component Service Information."

IV. Refrigeration Circuit and Component Service Information

⚠ WARNING

- This appliance should be diagnosed and repaired only by qualified service personnel to reduce the risk of death, electric shock, serious injury, or fire.
- Move the power switch to the "OFF" position and turn off the power supply. Place the disconnect in the "OFF" position. Lockout/Tagout to prevent the power supply from being turned back on inadvertently.
- **CHOKING HAZARD:** Ensure all components, fasteners, and thumbscrews are securely in place after the appliance is serviced. Make sure that none have fallen into the dispenser unit/ice storage bin.
- Make sure all food zones in the icemaker and dispenser unit/ice storage bin are clean after service.

A. Refrigeration Circuit Service Information

⚠ WARNING

- Repairs requiring the refrigeration circuit to be opened must be performed by properly trained and EPA-certified service personnel.
- Use an electronic leak detector or soap bubbles to check for leaks. Add a trace of refrigerant to the system (if using an electronic leak detector), and then raise the pressure using nitrogen gas (140 PSIG). Do not use R-404A as a mixture with pressurized air for leak testing.

NOTICE

- Always recover the refrigerant and store it in an approved container. Do not discharge the refrigerant into the atmosphere.
- Do not leave the system open for longer than 15 min. when replacing or servicing parts. The Polyol Ester (POE) oils used in R-404A applications can absorb moisture quickly. Therefore it is important to prevent moisture from entering the system when replacing or servicing parts.
- Always install a new drier every time the sealed refrigeration system is opened. Do not replace the drier until after all other repair or replacement has been made. Install the new drier with the arrow on the drier in the direction of the refrigerant flow.
- When brazing, protect the drier by using a wet cloth to prevent the drier from overheating. Do not allow the drier to exceed 250°F (121°C).

1. Refrigerant Recovery

Using proper refrigerant practices, recover the refrigerant. Recover via the access valves. Store the refrigerant in an approved container. Do not discharge the refrigerant into the atmosphere.

2. Brazing

⚠ WARNING

- R-404A itself is not flammable at atmospheric pressure and temperatures up to 176°F (80°C).
- R-404A itself is not explosive or poisonous. However, when exposed to high temperatures (open flames), R-404A can be decomposed to form hydrofluoric acid and carbonyl fluoride both of which are hazardous.
- Do not use silver alloy or copper alloy containing arsenic.

- 1) Braze all fittings while purging with nitrogen gas flowing at a pressure of 3 to 4 PSIG.

NOTICE

- Always install a new drier every time the sealed refrigeration system is opened.
- Do not replace the drier until after all other repair or replacement has been made. Install the new drier with the arrow on the drier in the direction of the refrigerant flow.
- When brazing, protect the drier by using a wet cloth to prevent the drier from overheating. Do not allow the drier to exceed 250°F (121°C).

- 2) Use an electronic leak detector or soap bubbles to check for leaks. Add a trace of refrigerant to the system (if using an electronic leak detector), and then raise the pressure using nitrogen gas (140 PSIG). Do not use R-404A as a mixture with pressurized air for leak testing.

3. Evacuation and Recharge (R-404A)

- 1) Attach a vacuum pump to the system. Be sure to connect the charging hoses to both high and low-side refrigerant access valves.

IMPORTANT

The vacuum level and vacuum pump may be the same as those for current refrigerants. However, the rubber hose and gauge manifold to be used for evacuation and refrigerant charge should be exclusively for POE oils.

- 2) Turn on the vacuum pump, then open the gauge manifold valves. Never allow the oil in the vacuum pump to flow backwards.
- 3) Allow the vacuum pump to pull down to a 29.9" Hg vacuum. Evacuating period depends on pump capacity.
- 4) Close the low-side valve and high-side valve on the gauge manifold.
- 5) Disconnect the gauge manifold hose from the vacuum pump and attach it to a refrigerant service cylinder. Remember to loosen the connection and purge the air from the hose. For the required refrigerant charge, see the nameplate. Hoshizaki recommends only virgin refrigerant or reclaimed refrigerant which meets ARI Standard 700 (latest edition) be used.

- 6) A liquid charge is required when charging an R-404A system (to prevent fractionation). Place the service cylinder on the scales; if the service cylinder is not equipped with a dip tube, invert the service cylinder, then place it on the scales. Open the high-side valve on the gauge manifold.
- 7) Allow the system to charge with liquid until the proper charge weight is met.
- 8) If necessary, add any remaining charge to the system through the low-side.
NOTICE! To prevent compressor damage, use a throttling valve or liquid dispensing device to add the remaining liquid charge through the low-side refrigerant access valve with the icemaker running.
- 9) Close the high and low-side gauge manifold valves, then disconnect the gauge manifold hoses.
- 10) Cap the refrigerant access valves to prevent a possible leak.

B. Component Service Information

NOTICE

- When replacing a component listed below, see the notes to help ensure proper operation.
- When replacing evaporator assembly and water circuit components, make sure there are no water leaks after the repair is complete.
- Seal bolts must be replaced once removed because seal material is one-time use only. If new seal bolts do not have preapplied threadlocker, apply Loctite 243 or equivalent threadlocker to seal bolt threads. Tighten to the torque values listed below.

Torque for F-1002 and Smaller: 11.1 ft-lb/15 N·m

Component	Notes
Compressor	<ul style="list-style-type: none"> • Install a new drier, start capacitor, and start relay.
Upper and Lower Bearings	<ul style="list-style-type: none"> • Inspect the upper bearing for wear. See "IV.B.1. Upper Bearing Wear Check." Replace if necessary. • When replacing the upper bearing it is advised to also change the lower bearing at the same time.
Evaporator	<ul style="list-style-type: none"> • Install a new drier. • Inspect the mechanical seal and O-ring prior to installing the new evaporator. If worn, cracked, or scratched, the mechanical seal should also be replaced.
Gear Motor	<ul style="list-style-type: none"> • Install a new gear motor capacitor.
Evaporator Pressure Regulator (EPR Valve)	MLJ models use with only R-404A, R-407A, or R-407F. R-404A EPR setting: 31 PSIG. R-407A EPR setting: 22 PSIG. R-407F EPR setting: 23 PSIG.

Evaporator Assembly

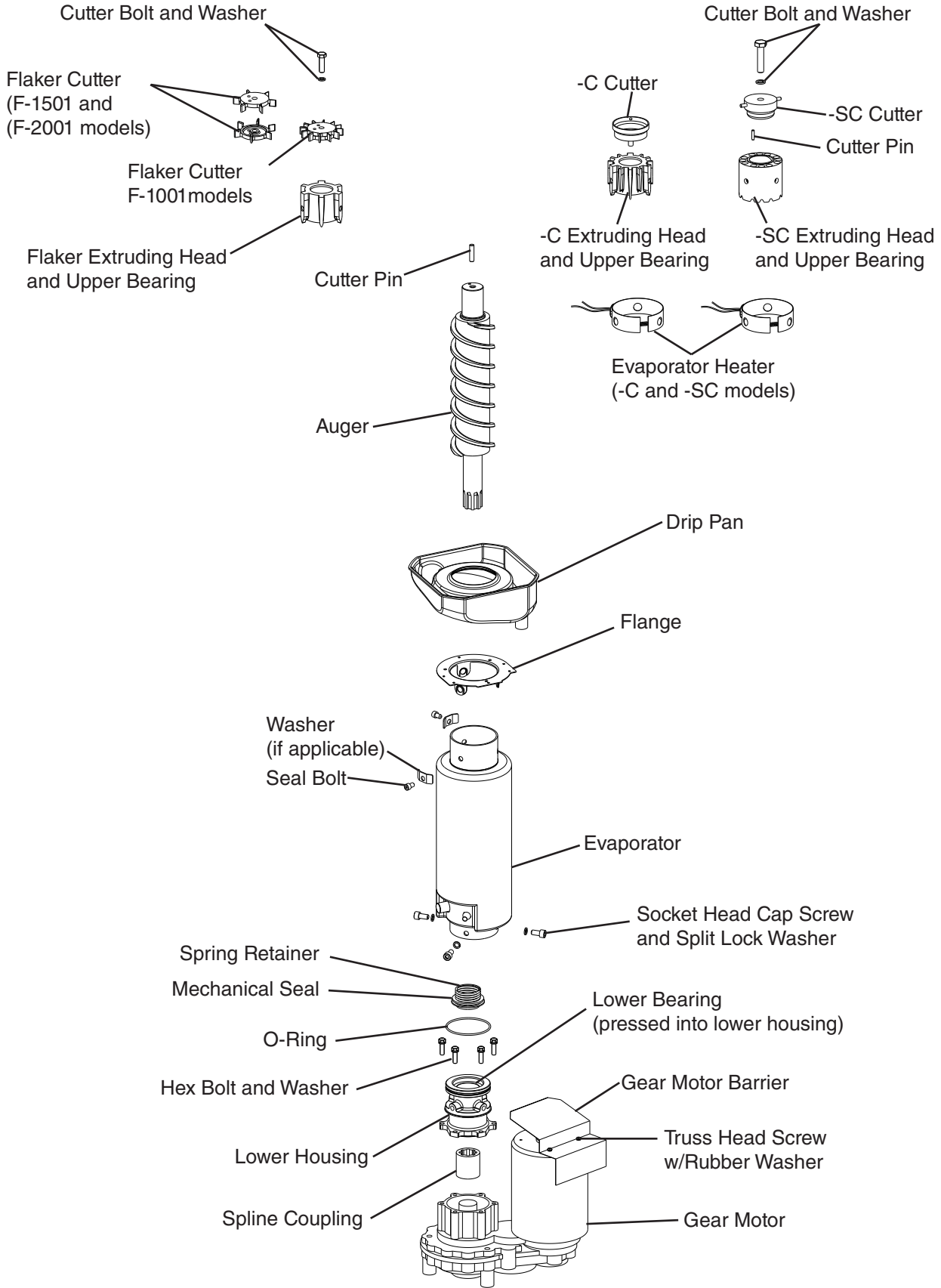

Fig. 13

1. Upper Bearing Wear Check

To ensure that the bearing inside the extruding head does not exceed the wear tolerance of .02", follow the instructions below.

- 1) Remove the front panel. Move the power switch to the "OFF" position, then turn off the power supply.
- 2) Remove the top and side panels.
- 3) Remove the strap connecting the spout to the chute assembly, then remove the spout.
- 4) Remove the bolt (if applicable) or cutter from the auger and lift off the cutter and washer (if applicable).

- 5) Replace the bolt in the auger (if applicable). See Fig. 14. Move the auger towards you and then try to insert a .02" round stock or pin gauge in between the back side of the auger shaft and the bearing surface. Check several locations around the auger shaft. If the gauge goes between the shaft and the bearing at any point or if the bearing is scratched or cracked, both the top bearing in the extruding head and the lower bearing in the housing should be replaced. Instructions for removing the extruding head and housing are located later in this procedure.

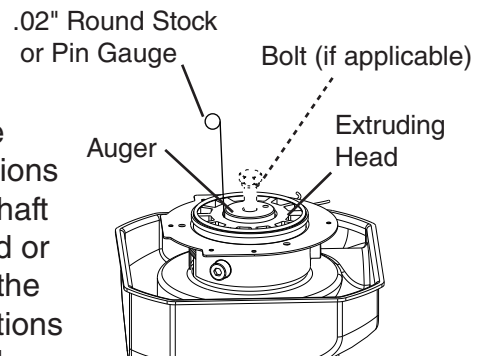

Fig. 14

Note: Replacing the bearing requires a bearing press adaptor. If one is not available, replace the whole extruding head and housing.

- 6) Replace the washer (if applicable), cutter, and cutter bolt (if applicable).
- 7) Replace the spout.
- 8) Replace the top and side panels in their correct positions.
- 9) Move the power switch to the "ON" position, then turn on the power supply.
- 10) Replace the front panel in its correct position.

2. Removal and Replacement of Cutter

- 1) Remove the front panel. Move the power switch to the "OFF" position, then turn off the power supply.
- 2) Remove the top and side panels.
- 3) Remove the strap connecting the spout to the chute assembly, then remove the spout.
- 4) Remove the bolt (if applicable) or cutter and lift off the cutter.
- 5) Install the new cutter. Replace the bolt (if applicable).
- 6) Replace the spout.
- 7) Replace the top and side panels in their correct position.
- 8) Move the power switch to the "ON" position, then turn on the power supply.
- 9) Replace the front panel in its correct position.

IMPORTANT! Seal Bolt Removal and Installation Instructions: Seal bolts must be replaced once removed because seal material is one-time use only. If new seal bolts do not have preapplied threadlocker, apply Loctite 243 or equivalent threadlocker to seal bolt threads.

- Torque for F-1002 and Smaller: 11.1 ft-lb/15 N·m

3. Removal and Replacement of Extruding Head

- 1) Drain the water from the evaporator.
 - a) Remove the front panel, then move the power switch to the "OFF" position.
 - b) Move the control switch to the "DRAIN" position.
 - c) Move the power switch to the "ON" position and allow the water to drain from the evaporator.
 - d) Move the power switch to the "OFF" position, then turn off the power supply.
- 2) Remove the top and side panels.
- 3) Remove the strap connecting the spout to the chute assembly, then remove the spout.
- 4) Remove the cutter bolt (if applicable) or cutter and lift off the cutter and washer (if applicable).
- 5) Remove the seal bolts from the extruding head and lift off the extruding head.
- 6) Place the new extruding head in place and tighten down with new seal bolts. See "Seal Bolt Removal and Installation Instructions" above.
- 7) Replace the washer (if applicable), cutter, cutter bolt (if applicable), and spout.
- 8) Replace the top and side panels in their correct positions.
- 9) Move the control switch to the "ICE" position.
- 10) Move the power switch to the "ON" position, then turn on the power supply.
- 11) Replace the front panel in its correct position.

4. Removal and Replacement of Auger

- 1) Drain the water from the evaporator.
 - a) Remove the front panel, then move the power switch to the "OFF" position.
 - b) Move the control switch to the "DRAIN" position.
 - c) Move the power switch to the "ON" position and allow the water to drain from the evaporator.
 - d) Move the power switch to the "OFF" position, then turn off the power supply.
- 2) Remove the top and side panels.
- 3) Remove the strap connecting the spout to the chute assembly, then remove the spout.
- 4) Remove the extruding head seal bolts. Using the cutter, lift out the auger assembly.
- 5) Remove the cutter bolt (if applicable), cutter, washer (if applicable), and dowel pin (if applicable). Remove the extruding head from the auger and place on the new auger.
- 6) Install the new auger.

- 7) Replace the removed parts in the reverse order of which they were removed.
Note: Be sure to use new seal bolts. See "Seal Bolt Removal and Installation Instructions" above.
- 8) Replace the top and side panels in their correct positions.
- 9) Move the control switch to the "ICE" position.
- 10) Move the power switch to the "ON" position, then turn on the power supply.
- 11) Replace the front panel in its correct position.

5. Removal and Replacement of Evaporator

<i>IMPORTANT</i>

Always install a new drier every time the sealed refrigeration system is opened. Do not replace the drier until after all other repair or replacement has been made.
--

- 1) Drain the water from the evaporator.
 - a) Remove the front panel, then move the power switch to the "OFF" position.
 - b) Move the control switch to the "DRAIN" position.
 - c) Move the power switch to the "ON" position and allow the water to drain from the evaporator.
 - d) Move the power switch to the "OFF" position, then turn off the power supply.
- 2) Remove the top and side panels.
- 3) Recover the refrigerant and store it in an approved container.
- 4) Remove the strap connecting the spout to the chute assembly, then remove the spout.
- 5) Disconnect the water hoses.
- 6) Remove the extruding head seal bolts. Using the cutter, lift out the auger assembly.
- 7) Remove the insulation and the expansion valve bulb on the suction line.
- 8) Disconnect the inlet and outlet tubing.
- 9) Remove the socket head cap screws and split lock washers securing the evaporator to the lower housing.
- 10) Lift off the evaporator.
- 11) Inspect the mechanical seal and O-ring prior to installing the new evaporator. The mechanical seal consists of two parts. One moves along with the auger, and the other is fixed on the lower housing. If the contact surfaces of these two parts are worn, cracked, or scratched, the mechanical seal may cause water leaks and should be replaced. Instructions for removing the mechanical seal and lower housing are located later in this procedure.
- 12) Make sure the lower mechanical seal is in place, then place the evaporator in position. Secure the evaporator to the lower housing using the socket head cap screws and split lock washers.
- 13) Remove the drier, then place the new drier in position.
- 14) Braze all fittings while purging with nitrogen gas flowing at a pressure of 3 to 4 PSIG.

- 15) Use an electronic leak detector or soap bubbles to check for leaks. Add a trace of refrigerant to the system (if using an electronic leak detector), and then raise the pressure using nitrogen gas (140 PSIG). Do not use R-404A as a mixture with pressurized air for leak testing.
- 16) Evacuate the system, and charge it with refrigerant. For air-cooled and water-cooled models, see the nameplate for the required refrigerant charge. For remote models, see the rating label inside the icemaker. Hoshizaki recommends only virgin refrigerant or reclaimed refrigerant which meets AHRI Standard 700 (latest edition) be used.
- 17) Replace the removed parts in the reverse order of which they were removed.
Note: Be sure to use new seal bolts. See "Seal Bolt Removal and Installation Instructions" earlier in this section.
- 18) Replace the top and side panels in their correct positions.
- 19) Move the control switch to the "ICE" position.
- 20) Move the power switch to the "ON" position, then turn on the power supply.
- 21) Replace the front panel in its correct position.

6. Removal and Replacement of Mechanical Seal and Lower Housing

6a. Mechanical Seal

- 1) Drain the water from the evaporator.
 - a) Remove the front panel, then move the power switch to the "OFF" position.
 - b) Move the control switch to the "DRAIN" position.
 - c) Move the power switch to the "ON" position and allow the water to drain from the evaporator.
 - d) Move the power switch to the "OFF" position, then turn off the power supply.
- 2) Remove the top and side panels.
- 3) Remove the strap connecting the spout to the chute assembly, then remove the spout.
- 4) Remove the extruding head seal bolts. Using the cutter, lift out the auger assembly.
- 5) The mechanical seal consists of two parts. One moves along with the auger, and the other is fixed on the lower housing. If the contact surfaces of these two parts are worn, cracked, or scratched, the mechanical seal may cause water leaks and should be replaced.
- 6) Remove the socket head cap screws and split lock washers securing the evaporator to the lower bearing housing.
- 7) Raise the evaporator up to access the lower housing.
- 8) Remove the O-ring and mechanical seal from the housing. If only replacing the mechanical seal, proceed to step 11.

<i>NOTICE</i>
To help prevent water leaks, be careful not to damage the surfaces of the O-ring or mechanical seal.

6b. Lower Housing

- 9) Remove the hex bolts w/washers securing the lower housing to the gear motor and remove the lower housing from the gear motor. If inspection of the upper bearing inside the extruding head (see "IV.B.1. Upper Bearing Wear Check") indicates that it is out of tolerance, replace both it and the bearing inside the lower housing.
Note: Replacing the bearing requires a bearing press adaptor. If one is not available, replace the whole extruding head and lower housing.
- 10) Mount the lower housing on the gear motor.
- 11) Install the O-ring and lower part of the mechanical seal on the lower housing.
- 12) Make sure the lower mechanical seal is in place, then place the evaporator in position. Secure the evaporator to the lower housing using the socket head cap screws and split lock washers.
- 13) Install the auger assembly with the upper part of the mechanical seal attached.
- 14) Replace the removed parts in the reverse order of which they were removed.
Note: Be sure to use new seal bolts. See "Seal Bolt Removal and Installation Instructions" earlier in this section.
- 15) Replace the top and side panels in their correct positions.
- 16) Move the control switch to the "ICE" position.
- 17) Move the power switch to the "ON" position, then turn on the power supply.
- 18) Replace the front panel in its correct position.

7. Removal and Replacement of Gear Motor

- 1) Drain the water from the evaporator.
 - a) Remove the front panel, then move the power switch to the "OFF" position.
 - b) Move the control switch to the "DRAIN" position.
 - c) Move the power switch to the "ON" position and allow the water to drain from the evaporator.
 - d) Move the power switch to the "OFF" position, then turn off the power supply.
- 2) Remove the top and side panels.
- 3) Remove the strap connecting the spout to the chute assembly, then remove the spout.
- 4) Remove the hex head bolts and washers securing the lower housing to the gear motor. Lift the evaporator up slightly.
- 5) Remove the socket head cap screws and split lock washers securing the gear motor.
- 6) Disconnect the gear motor wiring, then remove the gear motor.
- 7) Remove the gear motor bracket and spline coupling from the old gear motor and place on the new gear motor.
- 8) Install the new gear motor and re-connect the electrical wires.
- 9) Replace the removed parts in the reverse order of which they were removed.
- 10) Replace the top and side panels in their correct positions.
- 11) Move the control switch to the "ICE" position.
- 12) Move the power switch to the "ON" position, then turn on the power supply.
- 13) Replace the front panel in its correct position.

V. Maintenance

The appliance must be maintained in accordance with the instruction manual and labels provided. Consult with your local Hoshizaki Certified Service Representative about maintenance service. To obtain the name and phone number of your local Hoshizaki Certified Service Representative, visit www.hoshizakiamerica.com.

WARNING

- Only qualified service technicians should service the appliance.
- To reduce the risk of electric shock, do not touch the icemaker power switch or control switch with damp hands.
- **Before Servicing:** Move the icemaker's power switch to the "OFF" position. Turn off the power supply. Place the disconnect (if applicable) in the off position. Lockout/Tagout to prevent the power supply from being turned back on inadvertently.
- **CHOKING HAZARD:** Ensure all components, fasteners, and thumbscrews are securely in place after any maintenance is done to the appliance. Make sure that none have fallen into the dispenser unit/ice storage bin.

A. Maintenance Schedule

The maintenance schedule below is a guideline. More frequent maintenance may be required depending on water quality, the appliance's environment, and local sanitation regulations.

Maintenance Schedule		
Frequency	Area	Task
Daily	Scoop	Clean the ice scoop using a neutral cleaner. Rinse thoroughly after cleaning.
Bi-Weekly	Air Filters	Inspect. Wash with warm water and neutral cleaner if dirty.
Monthly	External Water Filters	Check for proper pressure and change if necessary.
	Icemaker Exterior	Wipe down with a clean, soft cloth. Use a damp cloth containing a neutral cleaner to wipe off oil or dirt build up. Clean any chlorine staining (rust colored spots) using a non-abrasive cleanser.
	Infrared Sensor Lens; Underside of Icemaker and Top Kits; Bin Door and Snout	Wipe down with a clean cloth and warm water.
	Ultrasonic Bin Control Lens	Wipe down the bin control lens, (located on the bottom of the icemaker) with a neutral cleaner. Rinse thoroughly after cleaning.
Every 6 Months	Icemaker and Dispenser Unit/Ice Storage Bin	Clean and sanitize per the cleaning and sanitizing instructions provided in the instruction manual or on maintenance label.
	Evaporator Condensate Drain Pan and Gear Motor Drain Pan	Wipe down with a clean cloth and warm water. Slowly pour one cup of sanitizing solution (prepare as outlined in the sanitizing instructions provided in the instruction manual) into the evaporator condensate drain pan and then slowly pour one cup into the gear motor drain pan. Be careful not to overflow the pans. Repeat with a cup of clean water to rinse.
	Icemaker and Dispenser Unit/Ice Storage Bin Drains	Check to make sure they are clear.
	Extruding Head Seal Bolts	Inspect for leakage around seal bolts. Tighten (see torque values below) or replace as necessary. Seal bolts must be replaced once removed because seal material is one-time use only. If new seal bolts do not have preapplied threadlocker, apply Loctite 243 or equivalent threadlocker to seal bolt threads. • <i>Torque for F-1002 and Smaller: 11.1 ft-lb/15 N·m</i>
Yearly	Inlet Water Valve and Drain Valve	Close the water supply line shut-off valve and drain the water system. Clean the inlet water valve screen and clean and inspect the drain valve.
	Water Hoses	Inspect the water hoses and clean/replace if necessary.
	Condenser	Inspect. Clean if necessary by using a brush or vacuum cleaner.
	Icemaker	Inspect for oil spots, loose components, fasteners, and wires.
	Upper Bearing (extruding head)	Check for wear using .02" round stock or pin gauge. Replace both upper bearing and lower bearing if wear exceeds factory recommendations.
After 3 Years, then Yearly	Upper Bearing (extruding head); Lower Bearing and O-Ring (lower housing); Mechanical Seal; Evaporator Cylinder; Auger	Inspect. Replace both upper bearing and lower bearing if wear exceeds factory recommendations. Replace the mechanical seal if the seal's contact surfaces are worn, cracked, or scratched.

VI. Disposal

The appliance contains refrigerant and must be disposed of in accordance with applicable national, state, and local codes and regulations. Refrigerant must be recovered by properly certified service personnel.

VII. Technical Information

We reserve the right to make changes in specifications and design without prior notice.

A. Specification & Performance Data Sheets

Note: The data in bold should be used for reference.

1a. F-450MAJ

Specification Sheet

AC SUPPLY VOLTAGE	115/60/1		
COMPRESSOR	115/60/1	8.4 RLA	50 LRA
GEAR MOTOR	115 V	2.4 FLA	1/4 HP
OTHER	115 V	0.03 A	
MAXIMUM FUSE SIZE	20 A		
MAX. HACR BREAKER (USA ONLY)	20 A		
MAX. CIRC. BREAKER (CANADA ONLY)	20 A		
MINIMUM CIRCUIT AMPACITY	20 A		
ELECTRIC & WATER CONSUMPTION	90/70°F	70/50°F	
ELECTRIC W (kWH/100 lbs.)	789(4.94)	760(3.71)	
POTABLE WATER	47(12.0)	59(12.0)	
	gal./24HR (gal./100 lbs.)		
SHAPE OF ICE	Flake		
ICE HARDNESS	Approx. 68%, Ice (90/70°F, Conductivity 200 µs/cm)		
BIN CONTROL SYSTEM	Ultrasonic Sensor		
REFRIGERANT CHARGE	R404A, 0 lb. 15.2 oz. (430g)		

Performance Data Sheet

APPROXIMATE ICE PRODUCTION PER 24 HR.	Ambient Temp. °F (°C)	Water Temp. °F (°C)		
		50 (10)	70 (21)	90 (32)
lbs./day (kg/day)	70 (21)	492 (223)	486 (220)	467 (212)
	80 (26)	449 (204)	432 (196)	415 (188)
	90 (32)	399 (181)	395 (179)	369 (167)
	100 (38)	355 (161)	341 (155)	315 (143)
APPROXIMATE ELECTRIC CONSUMPTION	70 (21)	760 --	764 --	769 --
	80 (26)	773 --	777 --	781 --
	90 (32)	785 --	789 --	796 --
	100 (38)	802 --	808 --	814 --
APPROXIMATE WATER CONSUMPTION PER 24 HR. (TOTAL) gal. / day (l/day)	70 (21)	59 (224)	58 (221)	56 (212)
	80 (26)	54 (204)	52 (196)	50 (189)
	90 (32)	48 (181)	47 (180)	44 (168)
	100 (38)	43 (161)	41 (155)	38 (143)
EVAPORATOR OUTLET TEMP. °F (°C)	70 (21)	0 ((-18))	1 ((-17))	3 ((-16))
	80 (26)	4 ((-15))	6 ((-15))	7 ((-14))
	90 (32)	9 ((-13))	10 ((-12))	9 ((-13))
	100 (38)	7 ((-14))	6 ((-15))	4 ((-15))
HEAD PRESSURE PSIG (kg/cm ² G)	70 (21)	191 (13.4)	199 (14.0)	207 (14.6)
	80 (26)	215 (15.1)	224 (15.7)	232 (16.3)
	90 (32)	240 (16.9)	248 (17.4)	259 (18.2)
	100 (38)	270 (19.0)	281 (19.7)	291 (20.5)
SUCTION PRESSURE PSIG (kg/cm ² G)	70 (21)	25 (1.8)	26 (1.8)	26 (1.8)
	80 (26)	27 (1.9)	27 (1.9)	28 (2.0)
	90 (32)	28 (2.0)	29 (2.0)	30 (2.1)
	100 (38)	30 (2.1)	31 (2.2)	31 (2.2)
HEAT OF REJECTION FROM CONDENSER	4,300 BTU/h (AT 90°F / WT 70°F)			
HEAT OF REJECTION FROM COMPRESSOR	700 BTU/h (AT 90°F / WT 70°F)			

1b. F-450MAJ-C

Specification Sheet

AC SUPPLY VOLTAGE	115/60/1		
COMPRESSOR	115/60/1	8.4 RLA	50 LRA
GEAR MOTOR	115 V	2.4 FLA	1/4 HP
OTHER	115 V	0.03 A	
MAXIMUM FUSE SIZE	15 A		
MAX. HACR BREAKER (USA ONLY)	15 A		
MAX. CIRC. BREAKER (CANADA ONLY)	15 A		
MINIMUM CIRCUIT AMPACITY	15 A		
ELECTRIC & WATER CONSUMPTION	90/70°F	70/50°F	
ELECTRIC W (kWH/100 lbs.)	813(6.10)	795(4.63)	
POTABLE WATER	38(12.0)	49(12.0)	
gal./24HR (gal./100 lbs.)			
SHAPE OF ICE	Cubelet		
ICE HARDNESS	Approx. 80.8%, Ice (90/70°F, Conductivity 200 µs/cm)		
BIN CONTROL SYSTEM	Ultrasonic Sensor		
REFRIGERANT CHARGE	R404A, 0 lb. 15.2 oz. (430g)		

Performance Data Sheet

APPROXIMATE ICE PRODUCTION PER 24 HR.	Ambient Temp. °F (°C)	Water Temp. °F (°C)		
		50 (10)	70 (21)	90 (32)
	70 (21)	412 (187)	400 (181)	384 (174)
	80 (26)	369 (168)	355 (161)	341 (155)
	90 (32)	328 (149)	316 (143)	303 (138)
lbs./day (kg/day)	100 (38)	292 (132)	280 (127)	267 (121)
APPROXIMATE ELECTRIC CONSUMPTION	70 (21)	795 --	798 --	800 --
	80 (26)	803 --	805 --	808 --
	90 (32)	811 --	813 --	825 --
	100 (38)	837 --	848 --	860 --
APPROXIMATE WATER CONSUMPTION PER 24 HR. (TOTAL) gal. / day (l/day)	70 (21)	49 (187)	48 (182)	46 (175)
	80 (26)	44 (168)	43 (161)	41 (155)
	90 (32)	39 (149)	38 (144)	36 (138)
	100 (38)	35 (133)	34 (127)	32 (121)
EVAPORATOR OUTLET TEMP. °F (°C)	70 (21)	5 ((-15))	5 ((-15))	6 ((-15))
	80 (26)	6 ((-14))	7 ((-14))	7 ((-14))
	90 (32)	8 ((-13))	8 ((-13))	10 ((-12))
	100 (38)	12 ((-11))	14 ((-10))	16 ((-9))
HEAD PRESSURE	70 (21)	194 (13.6)	202 (14.2)	210 (14.8)
	80 (26)	219 (15.4)	227 (16.0)	235 (16.5)
	90 (32)	244 (17.1)	252 (17.7)	261 (18.3)
	100 (38)	269 (18.9)	278 (19.5)	286 (20.1)
SUCTION PRESSURE PSIG (kg/cm ² G)	70 (21)	28 (2.0)	28 (2.0)	29 (2.0)
	80 (26)	29 (2.0)	29 (2.0)	29 (2.1)
	90 (32)	30 (2.1)	30 (2.1)	33 (2.3)
	100 (38)	36 (2.5)	38 (2.7)	41 (2.9)
HEAT OF REJECTION FROM CONDENSER		4,700	BTU/h (AT 90°F / WT 70°F)	
HEAT OF REJECTION FROM COMPRESSOR		800	BTU/h (AT 90°F / WT 70°F)	

2a. F-801MAJ

Specification Sheet

AC SUPPLY VOLTAGE	115/60/1	
COMPRESSOR	115/60/1	7.5 RLA 54.5 LRA
GEAR MOTOR	115 V	3.0 FLA 1/4 HP
FAN MOTOR	115 V	1.0 FLA 1/15 HP
OTHER	115 V	0.03 A
MAXIMUM FUSE SIZE	15 A	
MAX. HACR BREAKER (USA ONLY)	15 A	
MAX. CIRC. BREAKER (CANADA ONLY)	15 A	
MINIMUM CIRCUIT AMPACITY	15 A	
ELECTRIC & WATER CONSUMPTION	90/70°F	70/50°F
ELECTRIC W (kWH/100 lbs.)	1078 (4.50)	1022 (3.27)
POTABLE WATER gal./24HR (gal./100 lbs.)	68 (12.0)	90 (12.0)
SHAPE OF ICE	Flake	
ICE HARDNESS	Approx. 79.4%, Ice (90/70°F, Conductivity 200 µs/cm)	
BIN CONTROL SYSTEM	Ultrasonic Sensor	
REFRIGERANT CHARGE	R404A, 1 lb. 12 oz. (793g)	

Performance Data Sheet

APPROXIMATE ICE PRODUCTION PER 24 HR.	Ambient Temp. °F (°C)	Water Temp. °F (°C)					
		50 (10)		70 (21)		90 (32)	
70 (21)		751	(340)	730	(331)	699	(317)
80 (26)		669	(303)	640	(290)	612	(278)
90 (32)		586	(266)	566	(257)	537	(243)
100 (38)		514	(233)	492	(223)	462	(210)
lbs./day (kg/day)							
APPROXIMATE ELECTRIC CONSUMPTION	70 (21)	1022	--	1030	--	1038	--
80 (26)		1046	--	1054	--	1062	--
90 (32)		1070	--	1078	--	1089	--
100 (38)		1101	--	1113	--	1124	--
watts							
APPROXIMATE WATER CONSUMPTION PER 24 HR. (TOTAL)	70 (21)	90	(341)	88	(332)	84	(317)
80 (26)		80	(304)	77	(291)	74	(278)
90 (32)		70	(266)	68	(257)	64	(244)
100 (38)		62	(233)	59	(223)	55	(210)
gal. / day (l/day)							
EVAPORATOR OUTLET TEMP. °F (°C)	70 (21)	13	((-11))	13	((-11))	13	((-10))
80 (26)		14	((-10))	14	((-10))	14	((-10))
90 (32)		14	((-10))	15	((-10))	15	((-9))
100 (38)		16	((-9))	17	((-8))	17	((-8))
HEAD PRESSURE	70 (21)	202	(14.2)	210	(14.8)	219	(15.4)
80 (26)		227	(16.0)	236	(16.6)	245	(17.2)
90 (32)		253	(17.8)	262	(18.4)	273	(19.2)
100 (38)		284	(19.9)	294	(20.7)	305	(21.5)
PSIG (kg/cm ² G)							
SUCTION PRESSURE	70 (21)	39	(2.7)	39	(2.8)	40	(2.8)
80 (26)		40	(2.8)	40	(2.8)	41	(2.8)
90 (32)		41	(2.9)	41	(2.9)	42	(3.0)
100 (38)		43	(3.0)	44	(3.1)	44	(3.1)
PSIG (kg/cm ² G)							
HEAT OF REJECTION FROM CONDENSER		5,900	BTU/h (AT 90°F / WT 70°F)				
HEAT OF REJECTION FROM COMPRESSOR		900	BTU/h (AT 90°F / WT 70°F)				

2b. F-801MAJ-C

Specification Sheet

AC SUPPLY VOLTAGE	115/60/1		
COMPRESSOR	115/60/1	7.5 RLA	54.5 LRA
GEAR MOTOR	115 V	3.0 FLA	200W
FAN MOTOR	115 V	1.0 FLA	1/15 HP
OTHER	115 V	0.03 A	
MAXIMUM FUSE SIZE	15 A		
MAX. HACR BREAKER (USA ONLY)	15 A		
MAX. CIRC. BREAKER (CANADA ONLY)	15 A		
MINIMUM CIRCUIT AMPACITY	15 A		
ELECTRIC & WATER CONSUMPTION	90/70°F		70/50°F
ELECTRIC W (kWH/100 lbs.)	1104(5.00)		1078(3.75)
POTABLE WATER	64(12.0)		83(12.0)
WATER-COOLED CONDENSER			
gal./24HR (gal./100 lbs.)			
SHAPE OF ICE	Cubelet		
ICE HARDNESS	Approx. 86.6%, Ice (90/70°F, Conductivity 200 µs/cm)		
BIN CONTROL SYSTEM	Ultrasonic Sensor		
REFRIGERANT CHARGE	R404A, 1 lb. 12 oz. (790g)		

Performance Data Sheet

APPROXIMATE ICE PRODUCTION PER 24 HR. lbs./day (kg/day)	Ambient Temp. °F (°C)	Water Temp. °F (°C)		
		50 (10)	70 (21)	90 (32)
	70 (21)	690 (313)	670 (304)	645 (292)
	80 (26)	620 (281)	596 (270)	574 (260)
	90 (32)	552 (250)	532 (241)	510 (231)
	100 (38)	491 (223)	472 (214)	450 (204)
APPROXIMATE ELECTRIC CONSUMPTION watts	70 (21)	1078 --	1081 --	1085 --
	80 (26)	1089 --	1093 --	1096 --
	90 (32)	1100 --	1104 --	1117 --
	100 (38)	1130 --	1143 --	1156 --
APPROXIMATE WATER CONSUMPTION PER 24 HR. (TOTAL) gal. / day (l/day)	70 (21)	83 (314)	80 (305)	77 (293)
	80 (26)	74 (282)	72 (271)	69 (261)
	90 (32)	66 (251)	64 (242)	61 (232)
	100 (38)	59 (223)	57 (215)	54 (205)
EVAPORATOR OUTLET TEMP. °F (°C)	70 (21)	16 ((-9))	16 ((-9))	16 ((-9))
	80 (26)	17 ((-9))	17 ((-8))	17 ((-8))
	90 (32)	17 ((-8))	17 ((-8))	18 ((-8))
	100 (38)	19 ((-7))	19 ((-7))	20 ((-7))
HEAD PRESSURE PSIG (kg/cm ² G)	70 (21)	202 (14.2)	210 (14.8)	219 (15.4)
	80 (26)	228 (16.0)	237 (16.6)	245 (17.2)
	90 (32)	254 (17.9)	263 (18.5)	273 (19.2)
	100 (38)	282 (19.8)	292 (20.5)	302 (21.2)
SUCTION PRESSURE PSIG (kg/cm ² G)	70 (21)	39 (2.7)	39 (2.8)	40 (2.8)
	80 (26)	40 (2.8)	41 (2.9)	41 (2.9)
	90 (32)	42 (2.9)	42 (3.0)	43 (3.0)
	100 (38)	43 (3.0)	44 (3.1)	44 (3.1)
HEAT OF REJECTION FROM CONDENSER		5,000	BTU/h (AT 90°F / WT 70°F)	
HEAT OF REJECTION FROM COMPRESSOR		500	BTU/h (AT 90°F / WT 70°F)	

2c. F-801MWJ

Specification Sheet

AC SUPPLY VOLTAGE	115/60/1		
COMPRESSOR	115/60/1	7.5 RLA	54.5 LRA
GEAR MOTOR	115 V	3.0 FLA	200W
FAN MOTOR	115 V	1.0 FLA	1/15 HP
OTHER	115 V	0.03 A	
MAXIMUM FUSE SIZE	15 A		
MAX. HACR BREAKER (USA ONLY)	15 A		
MAX. CIRC. BREAKER (CANADA ONLY)	15 A		
MINIMUM CIRCUIT AMPACITY	15 A		
ELECTRIC & WATER CONSUMPTION	90/70°F	70/50°F	
ELECTRIC W (kWH/100 lbs.)	960(3.90)	963(3.39)	
POTABLE WATER	73(12.0)	82(12.0)	
WATER-COOLED CONDENSER	602(119.0)	334(49.1)	
	gal./24HR (gal./100 lbs.)		
SHAPE OF ICE	Flake		
ICE HARDNESS	Approx. 76.9%, Ice (90/70°F, Conductivity 200 µs/cm)		
BIN CONTROL SYSTEM	Ultrasonic Sensor		
REFRIGERANT CHARGE	R404A, 0 lb. 10.6 oz. (300g)		

Performance Data Sheet

APPROXIMATE ICE PRODUCTION PER 24 HR.	Ambient Temp. °F (°C)	Water Temp. °F (°C)		
		50 (10)	70 (21)	90 (32)
	70 (21)	680 (309)	681 (309)	663 (301)
	80 (26)	647 (293)	631 (286)	615 (279)
	90 (32)	599 (272)	605 (274)	570 (258)
lbs./day (kg/day)	100 (38)	556 (252)	542 (246)	506 (230)
APPROXIMATE ELECTRIC CONSUMPTION	70 (21)	963 --	962 --	962 --
	80 (26)	962 --	961 --	961 --
	90 (32)	961 --	960 --	963 --
	100 (38)	967 --	970 --	973 --
APPROXIMATE WATER CONSUMPTION PER 24 HR. (TOTAL) gal. / day (l/day)	70 (21)	416 (1573)	684 (2589)	1544 (5843)
	80 (26)	412 (1558)	678 (2566)	1538 (5821)
	90 (32)	406 (1537)	675 (2555)	1532 (5800)
	100 (38)	401 (1517)	667 (2526)	1525 (5771)
EVAPORATOR OUTLET TEMP. °F (°C)	70 (21)	17 ((-8))	18 ((-8))	18 ((-8))
	80 (26)	18 ((-8))	18 ((-8))	18 ((-8))
	90 (32)	18 ((-8))	18 ((-8))	18 ((-8))
	100 (38)	19 ((-7))	19 ((-7))	20 ((-7))
HEAD PRESSURE	70 (21)	228 (16.0)	229 (16.1)	230 (16.2)
	80 (26)	231 (16.2)	232 (16.3)	233 (16.4)
	90 (32)	234 (16.4)	235 (16.5)	238 (16.7)
	100 (38)	242 (17.0)	245 (17.2)	248 (17.5)
SUCTION PRESSURE PSIG (kg/cm ² G)	70 (21)	41 (2.9)	41 (2.9)	41 (2.9)
	80 (26)	41 (2.9)	41 (2.9)	41 (2.9)
	90 (32)	41 (2.9)	41 (2.9)	41 (2.9)
	100 (38)	41 (2.9)	42 (2.9)	42 (3.0)
WATER FLOW FOR CONDENSER	25 gal/h (AT 90°F / WT 70°F)			
PRESSURE DROP OF COOLING WATER LINE	Less than 7 PSIG			
HEAT OF REJECTION FROM CONDENSER	6,200 BTU/h (AT 90°F / WT 70°F)			
HEAT OF REJECTION FROM COMPRESSOR	900 BTU/h (AT 90°F / WT 70°F)			

2d. F-801MWJ-C

Specification Sheet

AC SUPPLY VOLTAGE	115/60/1		
COMPRESSOR	115/60/1	7.5 RLA	54.5 LRA
GEAR MOTOR	115 V	3.0 FLA	200W
FAN MOTOR	115 V	1.0 FLA	1/15 HP
OTHER	115 V	0.03 A	
MAXIMUM FUSE SIZE	15 A		
MAX. HACR BREAKER (USA ONLY)	15 A		
MAX. CIRC. BREAKER (CANADA ONLY)	15 A		
MINIMUM CIRCUIT AMPACITY	15 A		
ELECTRIC & WATER CONSUMPTION	90/70°F	70/50°F	
ELECTRIC W (kWH/100 lbs.)	977(4.13)	990(3.76)	
POTABLE WATER	70(12.0)	76(12.0)	
WATER-COOLED CONDENSER	634(120.0)	332(51.6)	
gal./24HR (gal./100 lbs.)			
SHAPE OF ICE	Cubelet		
ICE HARDNESS	Approx. 82%, Ice (90/70°F, Conductivity 200 µs/cm)		
BIN CONTROL SYSTEM	Ultrasonic Sensor		
REFRIGERANT CHARGE	R404A, 0 lb. 10.6 oz. (300g)		

Performance Data Sheet

APPROXIMATE ICE PRODUCTION PER 24 HR. lbs./day (kg/day)	Ambient Temp. °F (°C)	Water Temp. °F (°C)		
		50 (10)	70 (21)	90 (32)
	70 (21)	632 (287)	637 (289)	623 (282)
	80 (26)	609 (276)	595 (270)	582 (264)
	90 (32)	569 (258)	580 (263)	544 (247)
	100 (38)	532 (241)	520 (236)	484 (220)
APPROXIMATE ELECTRIC CONSUMPTION watts	70 (21)	990 --	988 --	986 --
	80 (26)	984 --	983 --	981 --
	90 (32)	979 --	977 --	984 --
	100 (38)	991 --	998 --	1006 --
APPROXIMATE WATER CONSUMPTION PER 24 HR. (TOTAL) gal. / day (l/day)	70 (21)	408 (1545)	711 (2690)	1648 (6239)
	80 (26)	405 (1535)	706 (2672)	1644 (6221)
	90 (32)	401 (1517)	704 (2665)	1639 (6204)
	100 (38)	396 (1500)	697 (2637)	1632 (6176)
EVAPORATOR OUTLET TEMP. °F (°C)	70 (21)	15 ((-9))	15 ((-9))	16 ((-9))
	80 (26)	16 ((-9))	16 ((-9))	16 ((-9))
	90 (32)	17 ((-9))	17 ((-8))	18 ((-8))
	100 (38)	18 ((-8))	19 ((-7))	19 ((-7))
HEAD PRESSURE PSIG (kg/cm ² G)	70 (21)	229 (16.1)	229 (16.1)	229 (16.1)
	80 (26)	230 (16.1)	230 (16.2)	231 (16.2)
	90 (32)	231 (16.2)	231 (16.3)	236 (16.6)
	100 (38)	240 (16.9)	245 (17.2)	249 (17.5)
SUCTION PRESSURE PSIG (kg/cm ² G)	70 (21)	38 (2.7)	38 (2.7)	39 (2.7)
	80 (26)	39 (2.7)	39 (2.7)	39 (2.7)
	90 (32)	39 (2.8)	39 (2.8)	40 (2.8)
	100 (38)	41 (2.8)	41 (2.9)	42 (2.9)
WATER FLOW FOR CONDENSER	26 gal/h (AT 90°F / WT 70°F)			
PRESSURE DROP OF COOLING WATER LINE	Less than 7 PSIG			
HEAT OF REJECTION FROM CONDENSER	6,000 BTU/h (AT 90°F / WT 70°F)			
HEAT OF REJECTION FROM COMPRESSOR	900 BTU/h (AT 90°F / WT 70°F)			

3. F-1002MLJ

Specification Sheet

AC SUPPLY VOLTAGE	115/60/1		
GEAR MOTOR	115 V	3.0 FLA	200 W
OTHER	115 V	0.03 A	
MAXIMUM FUSE SIZE	15 A		
MAX. HACR BREAKER (USA ONLY)	15 A		
MAX. CIRC. BREAKER (CANADA ONLY)	15 A		
MINIMUM CIRCUIT AMPACITY	15 A		
ELECTRIC & WATER CONSUMPTION	90/70°F	70/50°F	
ELECTRIC W (kWH/100 lbs.)	132(1.51)	130(1.20)	
POTABLE WATER	96(12.0)	123(12.0)	
gal./24HR (gal./100 lbs.)			
SHAPE OF ICE	Flake		
ICE HARDNESS	Approx. 72.8%, Ice (32/21 (90/70), Conductivity 200 µs/cm)		
BIN CONTROL SYSTEM	Ultrasonic Sensor		
CONDENSING UNIT	Required refrigeration capacity for ice maker is estimated at 8,600BTU/h. Suction pressure need to be set to (EPR): R404A - 31PSIG R407A - 22PSIG R407F - 23PSIG		
REFRIGERANT CONTROL	Evaporator Pressure Regulator (EPR)		
REFRIGERANT CHARGE	Nitrogen Holding Charge (5 PSIG) Can be used with refrigerant R404A, R407A, and R407F		

Performance Data Sheet

APPROXIMATE ICE PRODUCTION PER 24 HR.	Ambient Temp. °F (°C)	Water Temp. °F (°C)		
		50 (10)	70 (21)	90 (32)
lbs./day (kg/day)	70 (21)	1028 (466)	996 (452)	960 (436)
	80 (26)	926 (420)	893 (405)	861 (390)
	90 (32)	830 (376)	797 (362)	771 (350)
	100 (38)	743 (337)	717 (325)	690 (313)
APPROXIMATE ELECTRIC CONSUMPTION watts	70 (21)	130 --	130 --	131 --
	80 (26)	131 --	131 --	131 --
	90 (32)	132 --	132 --	133 --
	100 (38)	134 --	134 --	135 --
APPROXIMATE WATER CONSUMPTION PER 24 HR. (TOTAL) gal. / day (l/day) °F (°C)	70 (21)	123 (467)	120 (453)	115 (436)
	80 (26)	111 (421)	107 (406)	103 (391)
	90 (32)	100 (377)	96 (362)	93 (350)
	100 (38)	89 (338)	86 (326)	83 (314)
	80 (26)	17 ((-9))	17 ((-8))	17 ((-8))
	90 (32)	17 ((-8))	18 ((-8))	18 ((-8))
	100 (38)	19 ((-8))	19 ((-7))	19 ((-7))
	HEAD PRESSURE	70 (21)	205 (14.4)	212 (14.9)
	80 (26)	226 (15.9)	233 (16.4)	240 (16.9)
	90 (32)	247 (17.3)	254 (17.8)	259 (18.2)
PSIG (kg/cm2G)	100 (38)	264 (18.6)	270 (19.0)	275 (19.3)
SUCTION PRESSURE PSIG (kg/cm2G)	70 (21)	32 (2.2)	32 (2.3)	33 (2.3)
	80 (26)	33 (2.3)	34 (2.4)	34 (2.4)
	90 (32)	35 (2.4)	35 (2.5)	36 (2.5)
	100 (38)	37 (2.6)	37 (2.6)	38 (2.7)
HEAT OF REJECTION FROM CONDENSER		8,600 BTU/h (AT 90°F / WT 70°F)		

4a. F-1002MAJ

Specification Sheet

AC SUPPLY VOLTAGE	115/60/1		
COMPRESSOR	115/60/1	11.2 RLA	93 LRA
GEAR MOTOR	115 V	3.0 FLA	200 W
FAN MOTOR	115 V	1.0 FLA	1/15 HP
OTHER	115 V	0.03 A	
MAXIMUM FUSE SIZE	20 A		
MAX. HACR BREAKER (USA ONLY)	20 A		
MAX. CIRC. BREAKER (CANADA ONLY)	20 A		
MINIMUM CIRCUIT AMPACITY	20 A		
ELECTRIC & WATER CONSUMPTION	90/70°F		70/50°F
ELECTRIC W (kWH/100 lbs.)	1200(4.36)		1160(3.09)
POTABLE WATER	91(12.0)		118(12.0)
	gal./24HR (gal./100 lbs.)		
SHAPE OF ICE	Flake		
ICE HARDNESS	Approx. 80.1%, Ice (90/70°F, Conductivity 200 µs/cm)		
BIN CONTROL SYSTEM	Ultrasonic Sensor		
REFRIGERANT CHARGE	R404A, 2 lb. 4.2 oz. (1025g)		

Performance Data Sheet

APPROXIMATE ICE PRODUCTION PER 24 HR. lbs./day (kg/day)	Ambient Temp. °F (°C)	Water Temp. °F (°C)		
		50 (10)	70 (21)	90 (32)
	70 (21)	980 (445)	963 (437)	921 (418)
	80 (26)	881 (400)	843 (382)	806 (366)
	90 (32)	772 (350)	758 (344)	706 (320)
	100 (38)	676 (306)	646 (293)	595 (270)
APPROXIMATE ELECTRIC CONSUMPTION watts	70 (21)	1160 --	1166 --	1171 --
	80 (26)	1177 --	1183 --	1189 --
	90 (32)	1194 --	1200 --	1205 --
	100 (38)	1210 --	1215 --	1220 --
APPROXIMATE WATER CONSUMPTION PER 24 HR. (TOTAL) gal. / day (l/day)	70 (21)	118 (445)	116 (437)	111 (419)
	80 (26)	106 (400)	101 (383)	97 (367)
	90 (32)	93 (351)	91 (344)	85 (321)
	100 (38)	81 (307)	78 (294)	71 (270)
EVAPORATOR OUTLET TEMP. °F (°C)	70 (21)	19 (-7)	20 (-7)	20 (-7)
	80 (26)	20 (-7)	20 (-6)	21 (-6)
	90 (32)	21 (-6)	21 (-6)	22 (-6)
	100 (38)	22 (-6)	23 (-5)	23 (-5)
HEAD PRESSURE PSIG (kg/cm ² G)	70 (21)	213 (15.0)	222 (15.6)	230 (16.2)
	80 (26)	239 (16.8)	248 (17.4)	257 (18.0)
	90 (32)	265 (18.6)	274 (19.3)	284 (20.0)
	100 (38)	295 (20.7)	305 (21.4)	315 (22.1)
SUCTION PRESSURE PSIG (kg/cm ² G)	70 (21)	32 (2.2)	33 (2.3)	34 (2.4)
	80 (26)	35 (2.4)	35 (2.5)	36 (2.5)
	90 (32)	37 (2.6)	38 (2.7)	35 (2.4)
	100 (38)	32 (2.2)	28 (2.0)	25 (1.8)
HEAT OF REJECTION FROM CONDENSER	8,500 BTU/h (AT 90°F / WT 70°F)			
HEAT OF REJECTION FROM COMPRESSOR	1,400 BTU/h (AT 90°F / WT 70°F)			

4b. F-1002MAJ-C

Specification Sheet

AC SUPPLY VOLTAGE	115/60/1		
COMPRESSOR	115/60/1	11.2 RLA	93 LRA
GEAR MOTOR	115 V	3.0 FLA	200 W
FAN MOTOR	115 V	1.0 FLA	1/15 HP
OTHER	115 V	0.03 A	
MAXIMUM FUSE SIZE	20 A		
MAX. HACR BREAKER (USA ONLY)	20 A		
MAX. CIRC. BREAKER (CANADA ONLY)	20 A		
MINIMUM CIRCUIT AMPACITY	20 A		
ELECTRIC & WATER CONSUMPTION	90/70°F		70/50°F
ELECTRIC W (kWH/100 lbs.)	1366(4.57)		1301(3.51)
POTABLE WATER	87(12.0)		107(12.0)
gal./24HR (gal./100 lbs.)			
SHAPE OF ICE	Cubelet		
ICE HARDNESS	Approx. 87.1%, Ice (90/70°F, Conductivity 200 µs/cm)		
BIN CONTROL SYSTEM	Ultrasonic Sensor		
REFRIGERANT CHARGE	R404A, 2 lb. 4 oz. (1025g)		

Performance Data Sheet

APPROXIMATE ICE PRODUCTION PER 24 HR. lbs./day (kg/day)	Ambient Temp. °F (°C)	Water Temp. °F (°C)		
		50 (10)	70 (21)	90 (32)
	70 (21)	890 (404)	882 (400)	849 (385)
	80 (26)	817 (371)	786 (357)	757 (343)
	90 (32)	729 (331)	726 (329)	675 (306)
	100 (38)	650 (295)	625 (284)	575 (261)
APPROXIMATE ELECTRIC CONSUMPTION watts	70 (21)	1301 --	1310 --	1319 --
	80 (26)	1329 --	1338 --	1347 --
	90 (32)	1356 --	1366 --	1381 --
	100 (38)	1396 --	1411 --	1426 --
APPROXIMATE WATER CONSUMPTION PER 24 HR. (TOTAL) gal. / day (l/day)	70 (21)	107 (404)	106 (401)	102 (386)
	80 (26)	98 (371)	94 (357)	91 (344)
	90 (32)	87 (331)	87 (330)	81 (307)
	100 (38)	78 (295)	75 (284)	69 (261)
EVAPORATOR OUTLET TEMP. °F (°C)	70 (21)	16 ((-9))	16 ((-9))	16 ((-9))
	80 (26)	17 ((-9))	17 ((-8))	17 ((-8))
	90 (32)	17 ((-8))	18 ((-8))	18 ((-8))
	100 (38)	19 ((-8))	19 ((-7))	19 ((-7))
HEAD PRESSURE PSIG (kg/cm ² G)	70 (21)	213 (15.0)	222 (15.6)	231 (16.2)
	80 (26)	240 (16.8)	248 (17.5)	257 (18.1)
	90 (32)	266 (18.7)	275 (19.3)	285 (20.0)
	100 (38)	295 (20.7)	305 (21.4)	315 (22.1)
SUCTION PRESSURE PSIG (kg/cm ² G)	70 (21)	32 (2.2)	33 (2.3)	34 (2.4)
	80 (26)	35 (2.4)	35 (2.5)	36 (2.5)
	90 (32)	37 (2.6)	38 (2.7)	39 (2.7)
	100 (38)	40 (2.8)	40 (2.8)	41 (2.9)
HEAT OF REJECTION FROM CONDENSER		8,700	BTU/h (AT 90°F / WT 70°F)	
HEAT OF REJECTION FROM COMPRESSOR		1,400	BTU/h (AT 90°F / WT 70°F)	

4c. F-1002MAJ-SC

Specification Sheet

AC SUPPLY VOLTAGE	115/60/1		
COMPRESSOR	115/60/1	16.0 RLA	93 LRA
GEAR MOTOR	115V	3.0 FLA	200 W
FAN MOTOR	115V	1.0 FLA	1/15 HP
OTHER	115V	0.03 A	
MAXIMUM FUSE SIZE	20 A		
MAX. HACR BREAKER (USA ONLY)	20 A		
MAX. CIRC. BREAKER (CANADA ONLY)	20 A		
MINIMUM CIRCUIT AMPACITY	20 A		
ELECTRIC & WATER CONSUMPTION	90/70°F	70/50°F	
ELECTRIC W (kWH/100 lbs.)	1366(4.65)	1316(3.53)	
POTABLE WATER	84(12.0)	107(12.0)	
gal./24HR (gal./100 lbs.)			
SHAPE OF ICE	Soft Cubelet		
ICE HARDNESS	Approx. 87%, Ice (32/21 (90/70), Conductivity 200 µs/cm)		
BIN CONTROL SYSTEM	Ultrasonic Sensor		
REFRIGERANT CHARGE	R404A, 2 lb. 4 oz. (1025g)		

Performance Data Sheet

APPROXIMATE ICE PRODUCTION PER 24 HR.	Ambient	Water Temp. °F (°C)		
	Temp. °F (°C)	50 (10)	70 (21)	90 (32)
70 (21)	892 (405)	874 (396)	840 (381)	
90 (32)	716 (325)	700 (317)	661 (300)	
100 (38)	635 (288)	610 (277)	571 (259)	
lbs./day (kg/day)				
APPROXIMATE ELECTRIC CONSUMPTION	70 (21)	1316 --	1323 --	1331 --
80 (26)	1338 --	1345 --	1352 --	
90 (32)	1359 --	1366 --	1370 --	
watts	100 (38)	1374 --	1378 --	1381 --
APPROXIMATE WATER CONSUMPTION PER 24 HR. (TOTAL)	70 (21)	107 (405)	105 (397)	101 (382)
80 (26)	97 (367)	93 (352)	89 (338)	
90 (32)	86 (325)	84 (318)	79 (300)	
gal. / day (l/day)	100 (38)	76 (288)	73 (277)	69 (259)
EVAPORATOR OUTLET TEMP. °F (°C)	70 (21)	17 ((-8))	18 ((-8))	18 ((-8))
80 (26)	19 ((-7))	20 ((-7))	21 ((-6))	
90 (32)	22 ((-6))	22 ((-5))	23 ((-5))	
100 (38)	24 ((-5))	25 ((-4))	25 ((-4))	
HEAD PRESSURE	70 (21)	229 (16.1)	238 (16.8)	248 (17.4)
80 (26)	257 (18.0)	266 (18.7)	275 (19.3)	
90 (32)	284 (20.0)	294 (20.6)	303 (21.3)	
PSIG (kg/cm ² G)	100 (38)	312 (22.0)	322 (22.6)	331 (23.3)
SUCTION PRESSURE	70 (21)	32 (2.3)	32 (2.3)	32 (2.3)
PSIG (kg/cm ² G)	80 (26)	32 (2.3)	32 (2.3)	33 (2.3)
90 (32)	33 (2.3)	33 (2.3)	34 (2.4)	
100 (38)	35 (2.5)	37 (2.6)	38 (2.7)	
HEAT OF REJECTION FROM CONDENSER	8,700 BTU/h (AT 90°F / WT 70°F)			
HEAT OF REJECTION FROM COMPRESSOR	1,400 BTU/h (AT 90°F / WT 70°F)			

4d. F-1002MWJ

Specification Sheet

AC SUPPLY VOLTAGE	115/60/1		
COMPRESSOR	115/60/1	10.7 RLA	93 LRA
GEAR MOTOR	115 V	3.0 FLA	200W
FAN MOTOR	-		
OTHER	115 V	0.03 A	
MAXIMUM FUSE SIZE	20 A		
MAX. HACR BREAKER (USA ONLY)	20 A		
MAX. CIRC. BREAKER (CANADA ONLY)	20 A		
MINIMUM CIRCUIT AMPACITY	20 A		
ELECTRIC & WATER CONSUMPTION	90/70°F		70/50°F
ELECTRIC W (kWH/100 lbs.)	1224(3.57)		1215(3.06)
POTABLE WATER	100(12.0)		115(12.0)
WATER-COOLED CONDENSER	858(110.0)		462(48.4)
	gal./24HR (gal./100 lbs.)		
SHAPE OF ICE	Flake		
ICE HARDNESS	Approx. 79.0%, Ice (90/70°F, Conductivity 200 µs/cm)		
BIN CONTROL SYSTEM	Ultrasonic Sensor		
REFRIGERANT CHARGE	R404A, 0 lb. 12.3 oz. (350g)		

Performance Data Sheet

APPROXIMATE ICE PRODUCTION PER 24 HR.	Ambient Temp. °F (°C)	Water Temp. °F (°C)		
		50 (10)	70 (21)	90 (32)
	70 (21)	955 (433)	958 (434)	929 (421)
	80 (26)	901 (409)	873 (396)	847 (384)
	90 (32)	821 (373)	833 (378)	773 (350)
lbs./day (kg/day)	100 (38)	749 (340)	727 (330)	667 (302)
APPROXIMATE ELECTRIC CONSUMPTION	70 (21)	1215 --	1217 --	1218 --
	80 (26)	1219 --	1220 --	1222 --
	90 (32)	1223 --	1224 --	1235 --
watts	100 (38)	1245 --	1255 --	1265 --
APPROXIMATE WATER CONSUMPTION PER 24 HR. (TOTAL)	70 (21)	577 (2184)	973 (3681)	2007 (7597)
	80 (26)	570 (2159)	963 (3643)	1997 (7560)
	90 (32)	561 (2123)	958 (3625)	1988 (7526)
gal. / day (l/day)	100 (38)	552 (2090)	945 (3576)	1976 (7478)
EVAPORATOR OUTLET TEMP. °F (°C)	70 (21)	15 ((-9))	15 ((-9))	16 ((-9))
	80 (26)	16 ((-9))	17 ((-9))	17 ((-8))
	90 (32)	17 ((-8))	18 ((-8))	18 ((-8))
	100 (38)	19 ((-7))	19 ((-7))	20 ((-7))
HEAD PRESSURE	70 (21)	227 (16.0)	228 (16.0)	229 (16.1)
	80 (26)	230 (16.2)	231 (16.2)	232 (16.3)
	90 (32)	233 (16.4)	234 (16.5)	241 (16.9)
PSIG (kg/cm ² G)	100 (38)	247 (17.3)	253 (17.8)	259 (18.2)
SUCTION PRESSURE	70 (21)	31 (2.2)	31 (2.2)	31 (2.2)
PSIG (kg/cm ² G)	80 (26)	31 (2.2)	31 (2.2)	31 (2.2)
	90 (32)	31 (2.2)	31 (2.2)	32 (2.2)
	100 (38)	32 (2.3)	33 (2.3)	33 (2.3)
WATER FLOW FOR CONDENSER	36 gal/h (AT 90°F / WT 70°F)			
PRESSURE DROP OF COOLING WATER LINE	Less than 7 PSIG			
HEAT OF REJECTION FROM CONDENSER	8,200 BTU/h (AT 90°F / WT 70°F)			
HEAT OF REJECTION FROM COMPRESSOR	1,200 BTU/h (AT 90°F / WT 70°F)			

4e. F-1002MWJ-C

Specification Sheet

AC SUPPLY VOLTAGE	115/60/1		
COMPRESSOR	115/60/1	10.7 RLA	93 LRA
GEAR MOTOR	115 V	3.0 FLA	200W
FAN MOTOR	N/A		
OTHER	115 V	0.03 A	
MAXIMUM FUSE SIZE	20 A		
MAX. HACR BREAKER (USA ONLY)	20 A		
MAX. CIRC. BREAKER (CANADA ONLY)	20 A		
MINIMUM CIRCUIT AMPACITY	20 A		
ELECTRIC & WATER CONSUMPTION	90/70°F		70/50°F
ELECTRIC W (KWH/100 lbs.)	1224(3.95)		1215(3.47)
POTABLE WATER	92(12.0)		105(12.0)
WATER-COOLED CONDENSER	858(111.0)		462(54.5)
gal./24HR (gal./100 lbs.)			
SHAPE OF ICE	Cubelet		
ICE HARDNESS	Approx. 88.0%, Ice (90/70°F, Conductivity 200 µs/cm)		
BIN CONTROL SYSTEM	Ultrasonic Sensor		
REFRIGERANT CHARGE	R404A, 0 lb. 12.3 oz. (350g)		

Performance Data Sheet

APPROXIMATE ICE PRODUCTION PER 24 HR. lbs./day (kg/day)	Ambient Temp. °F (°C)	Water Temp. °F (°C)		
		50 (10)	70 (21)	90 (32)
	70 (21)	878 (398)	871 (395)	850 (386)
	80 (26)	830 (377)	810 (368)	791 (359)
	90 (32)	772 (350)	770 (349)	736 (334)
	100 (38)	718 (326)	701 (318)	667 (302)
APPROXIMATE ELECTRIC CONSUMPTION watts	70 (21)	1215 --	1217 --	1218 --
	80 (26)	1219 --	1220 --	1222 --
	90 (32)	1223 --	1224 --	1235 --
	100 (38)	1245 --	1255 --	1265 --
APPROXIMATE WATER CONSUMPTION PER 24 HR. (TOTAL) gal. / day (l/day)	70 (21)	568 (2149)	962 (3642)	1998 (7562)
	80 (26)	562 (2127)	955 (3615)	1991 (7535)
	90 (32)	555 (2101)	950 (3596)	1984 (7510)
	100 (38)	549 (2076)	942 (3565)	1976 (7478)
EVAPORATOR OUTLET TEMP. °F (°C)	70 (21)	15 ((-9))	15 ((-9))	16 ((-9))
	80 (26)	16 ((-9))	17 ((-9))	17 ((-8))
	90 (32)	17 ((-8))	18 ((-8))	18 ((-8))
	100 (38)	19 ((-7))	19 ((-7))	20 ((-7))
HEAD PRESSURE PSIG (kg/cm ² G)	70 (21)	227 (16.0)	228 (16.0)	229 (16.1)
	80 (26)	230 (16.2)	231 (16.2)	232 (16.3)
	90 (32)	233 (16.4)	234 (16.5)	241 (16.9)
	100 (38)	247 (17.3)	253 (17.8)	259 (18.2)
SUCTION PRESSURE PSIG (kg/cm ² G)	70 (21)	31 (2.2)	31 (2.2)	31 (2.2)
	80 (26)	31 (2.2)	31 (2.2)	31 (2.2)
	90 (32)	31 (2.2)	31 (2.2)	32 (2.2)
	100 (38)	32 (2.3)	33 (2.3)	33 (2.3)
WATER FLOW FOR CONDENSER	36 gal/h (AT 90°F / WT 70°F)			
PRESSURE DROP OF COOLING WATER LINE	Less than 7 PSIG			
HEAT OF REJECTION FROM CONDENSER	8,200 BTU/h (AT 90°F / WT 70°F)			
HEAT OF REJECTION FROM COMPRESSOR	1,200 BTU/h (AT 90°F / WT 70°F)			

4f. F-1002MRJZ

Specification Sheet

AC SUPPLY VOLTAGE	115/60/1		
COMPRESSOR	115/60/1	11.2 RLA	93 LRA
GEAR MOTOR	115 V	3.0 FLA	200 W
FAN MOTOR	115 V	1.0 FLA	
OTHER	115 V	0.03 A	
MAXIMUM FUSE SIZE	20 A		
MAX. HACR BREAKER (USA ONLY)	20 A		
MAX. CIRC. BREAKER (CANADA ONLY)	20 A		
MINIMUM CIRCUIT AMPACITY	20 A		
ELECTRIC & WATER CONSUMPTION	90/70°F		70/50°F
ELECTRIC W (kWH/100 lbs.)	1321(4.51)		1297(3.43)
POTABLE WATER	87(12.0)		109(12.0)
gal./24HR (gal./100 lbs.)			
SHAPE OF ICE	Flake		
ICE HARDNESS	Approx. 79.5%, Ice (32/21 (90/70), Conductivity 200 µs/cm)		
BIN CONTROL SYSTEM	Ultrasonic Sensor		
CONDENSER	Air Cooled Remote Condenser Unit URC-5FZ Recommended		
REFRIGERANT CHARGE	R404A, 4 lb. 1 oz. (1850g) Ice Maker: 2 lb. 3.3 oz. (1000g), Cond. Unit: 1 lb. 14 oz. (850g)		

Performance Data Sheet

APPROXIMATE ICE PRODUCTION PER 24 HR.	Ambient Temp. °F (°C)	Water Temp. °F (°C)		
		50 (10)	70 (21)	90 (32)
lbs./day (kg/day)	70 (21)	907 (411)	887 (403)	856 (388)
	80 (26)	825 (374)	796 (361)	767 (348)
	90 (32)	740 (336)	722 (327)	688 (312)
	100 (38)	663 (301)	640 (290)	605 (274)
APPROXIMATE ELECTRIC CONSUMPTION	70 (21)	1297 --	1300 --	1304 --
	80 (26)	1307 --	1311 --	1314 --
	90 (32)	1318 --	1321 --	1501 --
	100 (38)	1681 --	1860 --	2040 --
APPROXIMATE WATER CONSUMPTION PER 24 HR. (TOTAL) gal. / day (l/day)	70 (21)	109 (412)	107 (403)	103 (389)
	80 (26)	99 (375)	96 (362)	92 (349)
	90 (32)	89 (336)	87 (328)	83 (313)
	100 (38)	80 (301)	77 (291)	73 (275)
EVAPORATOR OUTLET TEMP. °F (°C)	70 (21)	16 ((-9))	16 ((-9))	16 ((-9))
	80 (26)	17 ((-9))	17 ((-8))	17 ((-8))
	90 (32)	17 ((-8))	18 ((-8))	18 ((-8))
	100 (38)	19 ((-8))	19 ((-7))	19 ((-7))
HEAD PRESSURE	70 (21)	205 (14.4)	212 (14.9)	219 (15.4)
	80 (26)	226 (15.9)	233 (16.4)	240 (16.9)
	90 (32)	247 (17.3)	254 (17.8)	259 (18.2)
	100 (38)	264 (18.6)	270 (19.0)	275 (19.3)
SUCTION PRESSURE PSIG (kq/cm ² G)	70 (21)	32 (2.2)	32 (2.3)	33 (2.3)
	80 (26)	33 (2.3)	34 (2.4)	34 (2.4)
	90 (32)	35 (2.4)	35 (2.5)	36 (2.5)
	100 (38)	37 (2.6)	37 (2.6)	38 (2.7)
CONDENSER VOLUME	44 cu. in.			
HEAT OF REJECTION FROM CONDENSER	8,600	BTU/h (AT 90°F / WT 70°F)		
HEAT OF REJECTION FROM COMPRESSOR	1,300	BTU/h (AT 90°F / WT 70°F)		

4g. F-1002MRJZ-C

Specification Sheet

AC SUPPLY VOLTAGE	115/60/1		
COMPRESSOR	115/60/1	11.2 RLA	93 LRA
GEAR MOTOR	115 V	3.0 FLA	200 W
FAN MOTOR	115 V	1.0 FLA	
OTHER	115 V	0.03 A	
MAXIMUM FUSE SIZE	20 A		
MAX. HACR BREAKER (USA ONLY)	20 A		
MAX. CIRC. BREAKER (CANADA ONLY)	20 A		
MINIMUM CIRCUIT AMPACITY	20 A		
ELECTRIC & WATER CONSUMPTION	90/70°F		70/50°F
ELECTRIC W (kWH/100 lbs.)	1393(4.94)		1333(3.90)
POTABLE WATER	82(12.0)		99(12.0)
	gal./24HR (gal./100 lbs.)		
SHAPE OF ICE	Cubelet		
ICE HARDNESS	Approx. 85.9%, Ice (32/21 (90/70), Conductivity 200 µs/cm)		
BIN CONTROL SYSTEM	Ultrasonic Sensor		
CONDENSER	Air Cooled Remote Condenser Unit URC-5FZ Recommended		
REFRIGERANT CHARGE	R404A, 4 lb. 1 oz. (1850g)		
	Ice Maker: 2 lb. 3.3 oz. (1000g), Cond. Unit: 1 lb. 14 oz. (850g)		

Performance Data Sheet

APPROXIMATE ICE PRODUCTION PER 24 HR.	Ambient Temp. °F (°C)	Water Temp. °F (°C)		
		50 (10)	70 (21)	90 (32)
lbs./day (kg/day)	70 (21)	821 (372)	808 (367)	783 (355)
	80 (26)	759 (344)	735 (333)	712 (323)
	90 (32)	690 (313)	680 (308)	648 (294)
	100 (38)	627 (285)	608 (276)	575 (261)
APPROXIMATE ELECTRIC CONSUMPTION	70 (21)	1333 --	1342 --	1350 --
	80 (26)	1359 --	1367 --	1376 --
	90 (32)	1384 --	1393 --	1395 --
	100 (38)	1396 --	1398 --	1400 --
APPROXIMATE WATER CONSUMPTION PER 24 HR. (TOTAL) gal. / day (l/day)	70 (21)	99 (373)	97 (367)	94 (356)
	80 (26)	91 (345)	88 (334)	86 (324)
	90 (32)	83 (314)	82 (309)	78 (294)
	100 (38)	75 (285)	73 (276)	69 (261)
EVAPORATOR OUTLET TEMP. °F (°C)	70 (21)	16 ((-9))	16 ((-9))	16 ((-9))
	80 (26)	17 ((-9))	17 ((-8))	17 ((-8))
	90 (32)	17 ((-8))	18 ((-8))	18 ((-8))
	100 (38)	19 ((-8))	19 ((-7))	19 ((-7))
HEAD PRESSURE	70 (21)	209 (14.7)	216 (15.2)	223 (15.7)
	80 (26)	230 (16.2)	237 (16.7)	244 (17.2)
	90 (32)	251 (17.7)	258 (18.2)	268 (18.8)
	100 (38)	277 (19.4)	286 (20.1)	295 (20.7)
SUCTION PRESSURE PSIG (kg/cm ² G)	70 (21)	32 (2.2)	32 (2.3)	33 (2.3)
	80 (26)	33 (2.3)	34 (2.4)	34 (2.4)
	90 (32)	35 (2.4)	35 (2.5)	36 (2.5)
	100 (38)	37 (2.6)	37 (2.6)	38 (2.7)
CONDENSER VOLUME	44 cu. in.			
HEAT OF REJECTION FROM CONDENSER	8,500 BTU/h (AT 90°F / WT 70°F)			
HEAT OF REJECTION FROM COMPRESSOR	1,300 BTU/h (AT 90°F / WT 70°F)			

4h. F-1002MRJZ-SC

Specification Sheet

AC SUPPLY VOLTAGE	115/60/1		
COMPRESSOR	115/60/1	11.2 RLA	93 LRA
GEAR MOTOR	115 V	3.0 FLA	200 W
FAN MOTOR	115 V	1.0 FLA	
OTHER	115 V	0.03 A	
MAXIMUM FUSE SIZE	20 A		
MAX. HACR BREAKER (USA ONLY)	20 A		
MAX. CIRC. BREAKER (CANADA ONLY)	20 A		
MINIMUM CIRCUIT AMPACITY	20 A		
ELECTRIC & WATER CONSUMPTION	90/70°F		70/50°F
ELECTRIC W (kWH/100 lbs.)	1409(5.15)		1341(3.73)
POTABLE WATER	79(12.0)		104(12.0)
gal./24HR (gal./100 lbs.)			
SHAPE OF ICE	Soft Cubelet		
ICE HARDNESS	Approx. 86.6%, Ice (32/21 (90/70), Conductivity 200 µs/cm)		
BIN CONTROL SYSTEM	Ultrasonic Sensor		
CONDENSER	Air Cooled Remote Condenser Unit URC-5FZ Recommended		
REFRIGERANT CHARGE	R404A, 4 lb. 1 oz. (1850g)		
	Ice Maker: 2 lb. 3.3 oz. (1000g), Cond. Unit: 1 lb. 14 oz. (850g)		

Performance Data Sheet

APPROXIMATE ICE PRODUCTION PER 24 HR.	Ambient Temp. °F (°C)	Water Temp. °F (°C)		
		50 (10)	70 (21)	90 (32)
lbs./day (kg/day)	70 (21)	864 (392)	837 (380)	805 (365)
	80 (26)	774 (351)	744 (338)	716 (325)
	90 (32)	688 (312)	660 (299)	636 (289)
	100 (38)	612 (277)	588 (267)	564 (256)
APPROXIMATE ELECTRIC CONSUMPTION	70 (21)	1341 --	1351 --	1361 --
	80 (26)	1370 --	1380 --	1390 --
	90 (32)	1400 --	1409 --	1414 --
	100 (38)	1418 --	1422 --	1426 --
APPROXIMATE WATER CONSUMPTION PER 24 HR. (TOTAL) gal. / day (l/day)	70 (21)	104 (393)	100 (380)	97 (366)
	80 (26)	93 (352)	89 (338)	86 (325)
	90 (32)	83 (313)	79 (300)	76 (289)
	100 (38)	73 (278)	71 (267)	68 (256)
EVAPORATOR OUTLET TEMP. °F (°C)	70 (21)	17 ((-8))	18 ((-8))	18 ((-8))
	80 (26)	19 ((-7))	20 ((-7))	21 ((-6))
	90 (32)	22 ((-6))	22 ((-5))	23 ((-5))
	100 (38)	24 ((-4))	25 ((-4))	26 ((-4))
HEAD PRESSURE	70 (21)	209 (14.7)	218 (15.3)	227 (15.9)
	80 (26)	236 (16.6)	245 (17.2)	254 (17.9)
	90 (32)	264 (18.5)	273 (19.2)	281 (19.7)
	100 (38)	289 (20.3)	298 (20.9)	306 (21.5)
SUCTION PRESSURE PSIG (kg/cm ² G)	70 (21)	32 (2.2)	32 (2.3)	33 (2.3)
	80 (26)	34 (2.4)	34 (2.4)	35 (2.4)
	90 (32)	35 (2.5)	36 (2.5)	37 (2.6)
	100 (38)	37 (2.6)	38 (2.6)	38 (2.7)
CONDENSER VOLUME	44 cu. in.			
HEAT OF REJECTION FROM CONDENSER	8,900 BTU/h (AT 90°F / WT 70°F)			
HEAT OF REJECTION FROM COMPRESSOR	1,300 BTU/h (AT 90°F / WT 70°F)			

5a. FD-650MAJ-C

Specification Sheet

AC SUPPLY VOLTAGE	115/60/1	
AMPERAGE	11.3 A	
MINIMUM CIRCUIT AMPACITY	20 A	
MAXIMUM FUSE SIZE	20 A	
ELECTRIC & WATER CONSUMPTION	90/70°F	70/50°F
ELECTRIC W (kWH/100 lbs.)	1108 (5.60)	1037 (3.79)
POTABLE WATER gal./24HR (gal./100 lbs.)	58 (12.0)	107 (12.0)
SHAPE OF ICE	Cubelet	
ICE HARDNESS	Approx. 87.0%, Ice (32/21 (90/70), Conductivity 200 µs/cm)	
BIN CONTROL SYSTEM	Ultrasonic Sensor	
REFRIGERANT CHARGE	R404A, 0 lb. 12.3 oz. (350g)	

Performance Data Sheet

APPROXIMATE ICE PRODUCTION PER 24 HR. lbs./day (kg/day)	Ambient Temp. °F (°C)	Water Temp. °F (°C)		
		50 (10)	70 (21)	90 (32)
	70 (21)	* 656 (298)	635 (288)	606 (275)
	80 (26)	579 (263)	* 553 (251)	528 (240)
	90 (32)	504 (229)	* 483 (219)	460 (209)
	100 (38)	440 (199)	420 (190)	* 396 (180)
APPROXIMATE ELECTRIC CONSUMPTION watts	70 (21)	* 1037 --	1047 --	1057 --
	80 (26)	1067 --	* 1077 --	1087 --
	90 (32)	1098 --	* 1108 --	1113 --
	100 (38)	1119 --	1125 --	* 1131 --
APPROXIMATE WATER CONSUMPTION PER 24 HR. (TOTAL) gal. / day (l/day)	70 (21)	* 79 (298)	76 (288)	73 (276)
	80 (26)	70 (263)	* 66 (251)	63 (240)
	90 (32)	61 (229)	* 58 (220)	55 (209)
	100 (38)	53 (200)	50 (191)	* 48 (180)
EVAPORATOR OUTLET TEMP. °F (°C)	70 (21)	* 19 ((-7))	19 ((-7))	20 ((-7))
	80 (26)	21 ((-6))	* 22 ((-6))	22 ((-5))
	90 (32)	23 ((-5))	* 24 ((-5))	24 ((-4))
	100 (38)	25 ((-4))	26 ((-3))	* 27 ((-3))
HEAD PRESSURE PSIG (kg/cm ² G)	70 (21)	* 252 (17.7)	262 (18.4)	272 (19.1)
	80 (26)	282 (19.8)	* 292 (20.5)	301 (21.2)
	90 (32)	311 (21.9)	* 321 (22.6)	331 (23.3)
	100 (38)	341 (24.0)	351 (24.6)	* 360 (25.3)
SUCTION PRESSURE PSIG (kg/cm ² G)	70 (21)	* 42 (3.0)	43 (3.0)	43 (3.0)
	80 (26)	44 (3.1)	* 45 (3.1)	45 (3.2)
	90 (32)	46 (3.2)	* 46 (3.3)	47 (3.3)
	100 (38)	47 (3.3)	48 (3.4)	* 49 (3.4)
HEAT OF REJECTION FROM CONDENSER	6,100 BTU/h (AT 90°F / WT 70°F)			
HEAT OF REJECTION FROM COMPRESSOR	1,100 BTU/h (AT 90°F / WT 70°F)			

5b. FD-650MWJ-C

Specification Sheet

AC SUPPLY VOLTAGE	115/60/1	
AMPERAGE	7.9 A	
MINIMUM CIRCUIT AMPACITY	20 A	
MAXIMUM FUSE SIZE	20 A	
ELECTRIC & WATER CONSUMPTION	90/70°F	70/50°F
ELECTRIC W (kWH/100 lbs.)	839 (3.90)	837 (3.25)
POTABLE WATER	63 (12.0)	107 (12.0)
WATER-COOLED CONDENSER	604 (115.0)	282 (45.6)
gal./24HR (gal./100 lbs.)		
SHAPE OF ICE	Cubelet	
ICE HARDNESS	Approx. 87.0%, Ice (32/21 (90/70), Conductivity 200 µs/cm)	
BIN CONTROL SYSTEM	Ultrasonic Sensor	
REFRIGERANT CHARGE	R404A, 0 lb. 15 oz. (425g)	

Performance Data Sheet

APPROXIMATE ICE PRODUCTION PER 24 HR. lbs./day (kg/day)	Ambient Temp. °F (°C)	Water Temp. °F (°C)		
		50 (10)	70 (21)	90 (32)
	70 (21)	* 618 (281)	611 (277)	594 (269)
	80 (26)	577 (262)	561 (255)	545 (247)
	90 (32)	530 (240)	* 525 (238)	501 (227)
	100 (38)	487 (221)	473 (215)	* 448 (203)
APPROXIMATE ELECTRIC CONSUMPTION watts	70 (21)	* 837 --	837 --	837 --
	80 (26)	838 --	838 --	838 --
	90 (32)	838 --	* 839 --	844 --
	100 (38)	850 --	855 --	* 861 --
APPROXIMATE WATER CONSUMPTION PER 24 HR. (TOTAL) gal. / day (l/day)	70 (21)	* 356 (1347)	620 (2347)	814 (3081)
	80 (26)	351 (1329)	614 (2324)	808 (3059)
	90 (32)	345 (1307)	* 610 (2308)	803 (3039)
	100 (38)	340 (1287)	603 (2284)	* 796 (3015)
EVAPORATOR OUTLET TEMP. °F (°C)	70 (21)	* 15 ((-10))	15 ((-9))	15 ((-9))
	80 (26)	16 ((-9))	16 ((-9))	16 ((-9))
	90 (32)	16 ((-9))	* 16 ((-9))	17 ((-9))
	100 (38)	17 ((-8))	17 ((-8))	* 18 ((-8))
HEAD PRESSURE PSIG (kg/cm ² G)	70 (21)	* 268 (18.9)	268 (18.9)	268 (18.9)
	80 (26)	268 (18.9)	268 (18.9)	268 (18.9)
	90 (32)	268 (18.9)	* 268 (18.9)	273 (19.2)
	100 (38)	277 (19.5)	282 (19.8)	* 286 (20.1)
SUCTION PRESSURE PSIG (kg/cm ² G)	70 (21)	* 41 (2.9)	41 (2.9)	41 (2.9)
	80 (26)	42 (2.9)	42 (2.9)	42 (3.0)
	90 (32)	42 (3.0)	* 43 (3.0)	43 (3.0)
	100 (38)	44 (3.1)	44 (3.1)	* 45 (3.2)
WATER FLOW FOR CONDENSER	25 gal/h (AT 90°F / WT 70°F)			
PRESSURE DROP OF COOLING WATER LINE	Less than 7 PSIG			
HEAT OF REJECTION FROM CONDENSER	5,400 BTU/h (AT 90°F / WT 70°F)			
HEAT OF REJECTION FROM COMPRESSOR	800 BTU/h (AT 90°F / WT 70°F)			

5c. FD-650MRJZ-C

Specification Sheet

AC SUPPLY VOLTAGE	115/60/1	
AMPERAGE	10.9 A	
MINIMUM CIRCUIT AMPACITY	20 A	
MAXIMUM FUSE SIZE	20 A	
ELECTRIC & WATER CONSUMPTION	90/70°F	70/50°F
ELECTRIC W (kWH/100 lbs.)	960 (4.80)	924 (3.65)
POTABLE WATER	58 (12.0)	107 (12.0)
gal./24HR (gal./100 lbs.)		
SHAPE OF ICE	Cubelet	
ICE HARDNESS	Approx. 87.0%, Ice (32/21 (90/70), Conductivity 200 µs/cm)	
BIN CONTROL SYSTEM	Ultrasonic Sensor	
CONDENSER	Air-cooled, Remote Condensing Unit, URC-5FZ	
REFRIGERANT CHARGE	R404A, 4 lb.1 oz. (1850g)	

Performance Data Sheet

APPROXIMATE ICE PRODUCTION PER 24 HR.	Ambient Temp. °F (°C)	Water Temp. °F (°C)		
		50 (10)	70 (21)	90 (32)
lbs./day (kg/day)	70 (21)	* 608 (276)	593 (269)	572 (259)
	80 (26)	551 (250)	531 (241)	512 (232)
	90 (32)	493 (224)	* 480 (218)	458 (208)
	100 (38)	441 (200)	425 (193)	* 403 (183)
APPROXIMATE ELECTRIC CONSUMPTION	70 (21)	* 924 --	929 --	934 --
	80 (26)	939 --	945 --	950 --
	90 (32)	955 --	* 960 --	966 --
	100 (38)	972 --	979 --	* 985 --
APPROXIMATE WATER CONSUMPTION PER 24 HR. (TOTAL) gal. / day (l/day)	70 (21)	* 73 (276)	71 (270)	69 (260)
	80 (26)	66 (250)	64 (241)	61 (233)
	90 (32)	59 (224)	* 58 (218)	55 (208)
	100 (38)	53 (200)	51 (193)	* 48 (183)
EVAPORATOR OUTLET TEMP. °F (°C)	70 (21)	* 19 ((-7))	19 ((-7))	20 ((-7))
	80 (26)	20 ((-7))	20 ((-6))	21 ((-6))
	90 (32)	21 ((-6))	* 21 ((-6))	22 ((-6))
	100 (38)	22 ((-6))	22 ((-5))	* 23 ((-5))
HEAD PRESSURE	70 (21)	* 196 (13.8)	203 (14.3)	210 (14.8)
	80 (26)	217 (15.3)	224 (15.8)	232 (16.3)
	90 (32)	239 (16.8)	* 246 (17.3)	253 (17.8)
	100 (38)	261 (18.3)	268 (18.8)	* 275 (19.3)
SUCTION PRESSURE PSIG (kg/cm ² G)	70 (21)	* 42 (2.9)	42 (3.0)	43 (3.0)
	80 (26)	43 (3.0)	43 (3.0)	44 (3.1)
	90 (32)	44 (3.1)	* 45 (3.1)	45 (3.2)
	100 (38)	45 (3.2)	46 (3.2)	* 46 (3.2)
CONDENSER VOLUME	44 cu. in.			
HEAT OF REJECTION FROM CONDENSER	5,900 BTU/h (AT 90°F / WT 70°F)			
HEAT OF REJECTION FROM COMPRESSOR	800 BTU/h (AT 90°F / WT 70°F)			

6a. FD-1002MAJ-C

Specification Sheet

AC SUPPLY VOLTAGE	115/60/1		
COMPRESSOR	115/60/1	11.2 RLA	93 LRA
GEAR MOTOR	115 V	3.0 FLA	200 W
FAN MOTOR	115 V	1.0 FLA	1/15 HP
OTHER	115 V	0.03 A	
MAXIMUM FUSE SIZE	20 A		
MAX. HACR BREAKER (USA ONLY)	20 A		
MAX. CIRC. BREAKER (CANADA ONLY)	20 A		
MINIMUM CIRCUIT AMPACITY	20 A		
ELECTRIC & WATER CONSUMPTION	90/70°F	70/50°F	
ELECTRIC W (kWH/100 lbs.)	1366 (4.57)	1301 (3.51)	
WATER gal./24HR (gal./100 lbs.)	87 (12.0)	107 (12.0)	
SHAPE OF ICE	Cubelet		
ICE HARDNESS	Approx. 87.1%, Ice (90/70°F, Conductivity 200 µs/cm)		
BIN CONTROL SYSTEM	Ultrasonic Sensor		
REFRIGERANT CHARGE	R404A, 2 lb. 4 oz. (1025g)		

Performance Data Sheet

APPROXIMATE ICE PRODUCTION PER 24 HR.	Ambient Temp. °F (°C)	Water Temp. °F (°C)		
		50 (10)	70 (21)	90 (32)
lbs./day (kg/day)	70 (21)	890 (404)	882 (400)	849 (385)
	80 (26)	817 (371)	786 (357)	757 (343)
	90 (32)	729 (331)	726 (329)	675 (306)
	100 (38)	650 (295)	625 (284)	575 (261)
APPROXIMATE ELECTRIC CONSUMPTION	70 (21)	1301 --	1310 --	1319 --
	80 (26)	1329 --	1338 --	1347 --
	90 (32)	1356 --	1366 --	1381 --
	100 (38)	1396 --	1411 --	1426 --
APPROXIMATE WATER CONSUMPTION PER 24 HR. (TOTAL) gal. / day (l/day)	70 (21)	107 (404)	106 (401)	102 (386)
	80 (26)	98 (371)	94 (357)	91 (344)
	90 (32)	87 (331)	87 (330)	81 (307)
	100 (38)	78 (295)	75 (284)	69 (261)
EVAPORATOR OUTLET TEMP. °F (°C)	70 (21)	16 ((-9))	16 ((-9))	16 ((-9))
	80 (26)	17 ((-9))	17 ((-8))	17 ((-8))
	90 (32)	17 ((-8))	18 ((-8))	18 ((-8))
	100 (38)	19 ((-8))	19 ((-7))	19 ((-7))
HEAD PRESSURE	70 (21)	213 (15.0)	222 (15.6)	231 (16.2)
	80 (26)	240 (16.8)	248 (17.5)	257 (18.1)
	90 (32)	266 (18.7)	275 (19.3)	285 (20.0)
	100 (38)	295 (20.7)	305 (21.4)	315 (22.1)
SUCTION PRESSURE PSIG (kg/cm ² G)	70 (21)	32 (2.2)	33 (2.3)	34 (2.4)
	80 (26)	35 (2.4)	35 (2.5)	36 (2.5)
	90 (32)	37 (2.6)	38 (2.7)	39 (2.7)
	100 (38)	40 (2.8)	40 (2.8)	41 (2.9)
HEAT OF REJECTION FROM CONDENSER	8,700 BTU/h (AT 90°F / WT 70°F)			
HEAT OF REJECTION FROM COMPRESSOR	1,400 BTU/h (AT 90°F / WT 70°F)			

6b. FD-1002MAJ-CB

Specification Sheet

AC SUPPLY VOLTAGE	115/60/1		
COMPRESSOR	115/60/1	11.2 RLA	93 LRA
GEAR MOTOR	115 V	3.0 FLA	200 W
FAN MOTOR	115 V	1.0 FLA	1/15 HP
OTHER	115 V	0.03 A	
MAXIMUM FUSE SIZE	20 A		
MAX. HACR BREAKER (USA ONLY)	20 A		
MAX. CIRC. BREAKER (CANADA ONLY)	20 A		
MINIMUM CIRCUIT AMPACITY	20 A		
ELECTRIC & WATER CONSUMPTION	90/70°F	70/50°F	
ELECTRIC W (kWH/100 lbs.)	1366 (4.57)	1301 (3.51)	
WATER gal./24HR (gal./100 lbs.)	87 (12.0)	107 (12.0)	
SHAPE OF ICE	Cubelet		
ICE HARDNESS	Approx. 87.1%, Ice (90/70°F, Conductivity 200 µs/cm)		
BIN CONTROL SYSTEM	Ultrasonic Sensor		
REFRIGERANT CHARGE	R404A, 2 lb. 4 oz. (1025g)		

Performance Data Sheet

APPROXIMATE ICE PRODUCTION PER 24 HR.	Ambient Temp. °F (°C)	Water Temp. °F (°C)		
		50 (10)	70 (21)	90 (32)
	70 (21)	890 (404)	882 (400)	849 (385)
	80 (26)	817 (371)	786 (357)	757 (343)
	90 (32)	729 (331)	726 (329)	675 (306)
lbs./day (kg/day)	100 (38)	650 (295)	625 (284)	575 (261)
APPROXIMATE ELECTRIC CONSUMPTION	70 (21)	1301 --	1310 --	1319 --
	80 (26)	1329 --	1338 --	1347 --
	90 (32)	1356 --	1366 --	1381 --
	100 (38)	1396 --	1411 --	1426 --
APPROXIMATE WATER CONSUMPTION PER 24 HR. (TOTAL) gal. / day (l/day)	70 (21)	107 (404)	106 (401)	102 (386)
	80 (26)	98 (371)	94 (357)	91 (344)
	90 (32)	87 (331)	87 (330)	81 (307)
	100 (38)	78 (295)	75 (284)	69 (261)
EVAPORATOR OUTLET TEMP. °F (°C)	70 (21)	16 ((-9))	16 ((-9))	16 ((-9))
	80 (26)	17 ((-9))	17 ((-8))	17 ((-8))
	90 (32)	17 ((-8))	18 ((-8))	18 ((-8))
	100 (38)	19 ((-8))	19 ((-7))	19 ((-7))
HEAD PRESSURE	70 (21)	213 (15.0)	222 (15.6)	231 (16.2)
	80 (26)	240 (16.8)	248 (17.5)	257 (18.1)
	90 (32)	266 (18.7)	275 (19.3)	285 (20.0)
	100 (38)	295 (20.7)	305 (21.4)	315 (22.1)
SUCTION PRESSURE PSIG (kg/cm ² G)	70 (21)	32 (2.2)	33 (2.3)	34 (2.4)
	80 (26)	35 (2.4)	35 (2.5)	36 (2.5)
	90 (32)	37 (2.6)	38 (2.7)	39 (2.7)
	100 (38)	40 (2.8)	40 (2.8)	41 (2.9)
HEAT OF REJECTION FROM CONDENSER		8,700 BTU/h (AT 90°F / WT 70°F)		
HEAT OF REJECTION FROM COMPRESSOR		1,400 BTU/h (AT 90°F / WT 70°F)		

6c. FD-1002MRJZ-C

Specification Sheet

AC SUPPLY VOLTAGE	115/60/1		
COMPRESSOR	115/60/1	11.2 RLA	93 LRA
GEAR MOTOR	115 V	3.0 FLA	200 W
FAN MOTOR	115 V	1.0 FLA	
OTHER	115 V	0.03 A	
MAXIMUM FUSE SIZE	20 A		
MAX. HACR BREAKER (USA ONLY)	20 A		
MAX. CIRC. BREAKER (CANADA ONLY)	20 A		
MINIMUM CIRCUIT AMPACITY	20 A		
ELECTRIC & WATER CONSUMPTION	90/70°F		70/50°F
ELECTRIC W (kWH/100 lbs.)	1393(4.94)		1333(3.90)
POTABLE WATER	82(12.0)		99(12.0)
gal./24HR (gal./100 lbs.)			
SHAPE OF ICE	Cubelet		
ICE HARDNESS	Approx. 85.9%, Ice (32/21 (90/70), Conductivity 200 µs/cm)		
BIN CONTROL SYSTEM	Ultrasonic Sensor		
CONDENSER	Air-cooled remote condenser, URC-5FZ		
REFRIGERANT CHARGE	R404A, 4 lb. 1 oz. (1850g)		
	Ice Maker: 2 lb. 3.3 oz. (1000g), Cond. Unit: 1 lb. 14 oz. (850g)		

Performance Data Sheet

APPROXIMATE ICE PRODUCTION PER 24 HR.	Ambient Temp. °F (°C)	Water Temp. °F (°C)		
		50 (10)	70 (21)	90 (32)
	70 (21)	821 (372)	808 (367)	783 (355)
	80 (26)	759 (344)	735 (333)	712 (323)
	90 (32)	690 (313)	680 (308)	648 (294)
lbs./day (kg/day)	100 (38)	627 (285)	608 (276)	575 (261)
APPROXIMATE ELECTRIC CONSUMPTION	70 (21)	1333 --	1342 --	1350 --
	80 (26)	1359 --	1367 --	1376 --
	90 (32)	1384 --	1393 --	1395 --
watts	100 (38)	1396 --	1398 --	1400 --
APPROXIMATE WATER CONSUMPTION PER 24 HR. (TOTAL)	70 (21)	99 (373)	97 (367)	94 (356)
	80 (26)	91 (345)	88 (334)	86 (324)
	90 (32)	83 (314)	82 (309)	78 (294)
gal. / day (l/day)	100 (38)	75 (285)	73 (276)	69 (261)
EVAPORATOR OUTLET TEMP. °F (°C)	70 (21)	16 ((-9))	16 ((-9))	16 ((-9))
	80 (26)	17 ((-9))	17 ((-8))	17 ((-8))
	90 (32)	17 ((-8))	18 ((-8))	18 ((-8))
	100 (38)	19 ((-8))	19 ((-7))	19 ((-7))
HEAD PRESSURE	70 (21)	209 (14.7)	216 (15.2)	223 (15.7)
	80 (26)	230 (16.2)	237 (16.7)	244 (17.2)
	90 (32)	251 (17.7)	258 (18.2)	268 (18.8)
PSIG (kg/cm ² G)	100 (38)	277 (19.4)	286 (20.1)	295 (20.7)
SUCTION PRESSURE	70 (21)	32 (2.2)	32 (2.3)	33 (2.3)
PSIG (kg/cm ² G)	80 (26)	33 (2.3)	34 (2.4)	34 (2.4)
	90 (32)	35 (2.4)	35 (2.5)	36 (2.5)
	100 (38)	37 (2.6)	37 (2.6)	38 (2.7)
CONDENSER VOLUME	44 cu. in.			
HEAT OF REJECTION FROM CONDENSER	8,500 BTU/h (AT 90°F / WT 70°F)			
HEAT OF REJECTION FROM COMPRESSOR	1,300 BTU/h (AT 90°F / WT 70°F)			

6d. FD-1002MRJZ-CB

Specification Sheet

AC SUPPLY VOLTAGE	115/60/1		
COMPRESSOR	115/60/1	11.2 RLA	93 LRA
GEAR MOTOR	115 V	3.0 FLA	200 W
FAN MOTOR	115 V	1.0 FLA	
OTHER	115 V	0.03 A	
MAXIMUM FUSE SIZE	20 A		
MAX. HACR BREAKER (USA ONLY)	20 A		
MAX. CIRC. BREAKER (CANADA ONLY)	20 A		
MINIMUM CIRCUIT AMPACITY	20 A		
ELECTRIC & WATER CONSUMPTION	90/70°F		70/50°F
ELECTRIC W (kWH/100 lbs.)	1393(4.94)		1333(3.90)
POTABLE WATER	82(12.0)		99(12.0)
gal./24HR (gal./100 lbs.)			
SHAPE OF ICE	Cubelet		
ICE HARDNESS	Approx. 85.9%, Ice (32/21 (90/70), Conductivity 200 μs/cm)		
BIN CONTROL SYSTEM	Ultrasonic Sensor		
CONDENSER	Air-cooled remote condenser, URC-5FZ		
REFRIGERANT CHARGE	R404A, 4 lb. 1 oz. (1850g)		
	Ice Maker: 2 lb. 3.3 oz. (1000g), Cond. Unit: 1 lb. 14 oz. (850g)		

Performance Data Sheet

APPROXIMATE ICE PRODUCTION PER 24 HR.	Ambient Temp. °F (°C)	Water Temp. °F (°C)		
		50 (10)	70 (21)	90 (32)
	70 (21)	821 (372)	808 (367)	783 (355)
	80 (26)	759 (344)	735 (333)	712 (323)
	90 (32)	690 (313)	680 (308)	648 (294)
lbs./day (kg/day)	100 (38)	627 (285)	608 (276)	575 (261)
APPROXIMATE ELECTRIC CONSUMPTION	70 (21)	1333 --	1342 --	1350 --
	80 (26)	1359 --	1367 --	1376 --
	90 (32)	1384 --	1393 --	1395 --
watts	100 (38)	1396 --	1398 --	1400 --
APPROXIMATE WATER CONSUMPTION PER 24 HR. (TOTAL)	70 (21)	99 (373)	97 (367)	94 (356)
	80 (26)	91 (345)	88 (334)	86 (324)
	90 (32)	83 (314)	82 (309)	78 (294)
gal. / day (l/day)	100 (38)	75 (285)	73 (276)	69 (261)
EVAPORATOR OUTLET TEMP. °F (°C)	70 (21)	16 ((-9))	16 ((-9))	16 ((-9))
	80 (26)	17 ((-9))	17 ((-8))	17 ((-8))
	90 (32)	17 ((-8))	18 ((-8))	18 ((-8))
	100 (38)	19 ((-8))	19 ((-7))	19 ((-7))
HEAD PRESSURE	70 (21)	209 (14.7)	216 (15.2)	223 (15.7)
	80 (26)	230 (16.2)	237 (16.7)	244 (17.2)
	90 (32)	251 (17.7)	258 (18.2)	268 (18.8)
PSIG (kq/cm ² G)	100 (38)	277 (19.4)	286 (20.1)	295 (20.7)
SUCTION PRESSURE	70 (21)	32 (2.2)	32 (2.3)	33 (2.3)
PSIG (kq/cm ² G)	80 (26)	33 (2.3)	34 (2.4)	34 (2.4)
	90 (32)	35 (2.4)	35 (2.5)	36 (2.5)
	100 (38)	37 (2.6)	37 (2.6)	38 (2.7)
CONDENSER VOLUME	44 cu. in.			
HEAT OF REJECTION FROM CONDENSER	8,500 BTU/h (AT 90°F / WT 70°F)			
HEAT OF REJECTION FROM COMPRESSOR	1,300 BTU/h (AT 90°F / WT 70°F)			

B. Wiring Diagrams

1. F-450MAJ(-C)

a) N-2 Auxiliary Code (Infrared Bin Control 1)

S1 DIP SWITCH SETTING	1	2	3	4	5	6	7	8	9	10
F-450M..J/-C	ON	OFF	OFF	OFF	OFF	OFF	ON	ON	OFF	OFF

- WIRE COLOR CODE
- BK - BLACK
 - BR - BROWN
 - BU - BLUE
 - DBU - DARK BLUE
 - GR - GREEN
 - GY - GRAY
 - LBU - LIGHT BLUE
 - O - ORANGE
 - P - PINK
 - R - RED
 - V - VIOLET
 - W - WHITE
 - Y - YELLOW
 - W/BK - WHITE BLACK
 - W/BR - WHITE BROWN
 - W/BU - WHITE BLUE
 - W/O - WHITE ORANGE
 - W/R - WHITE RED

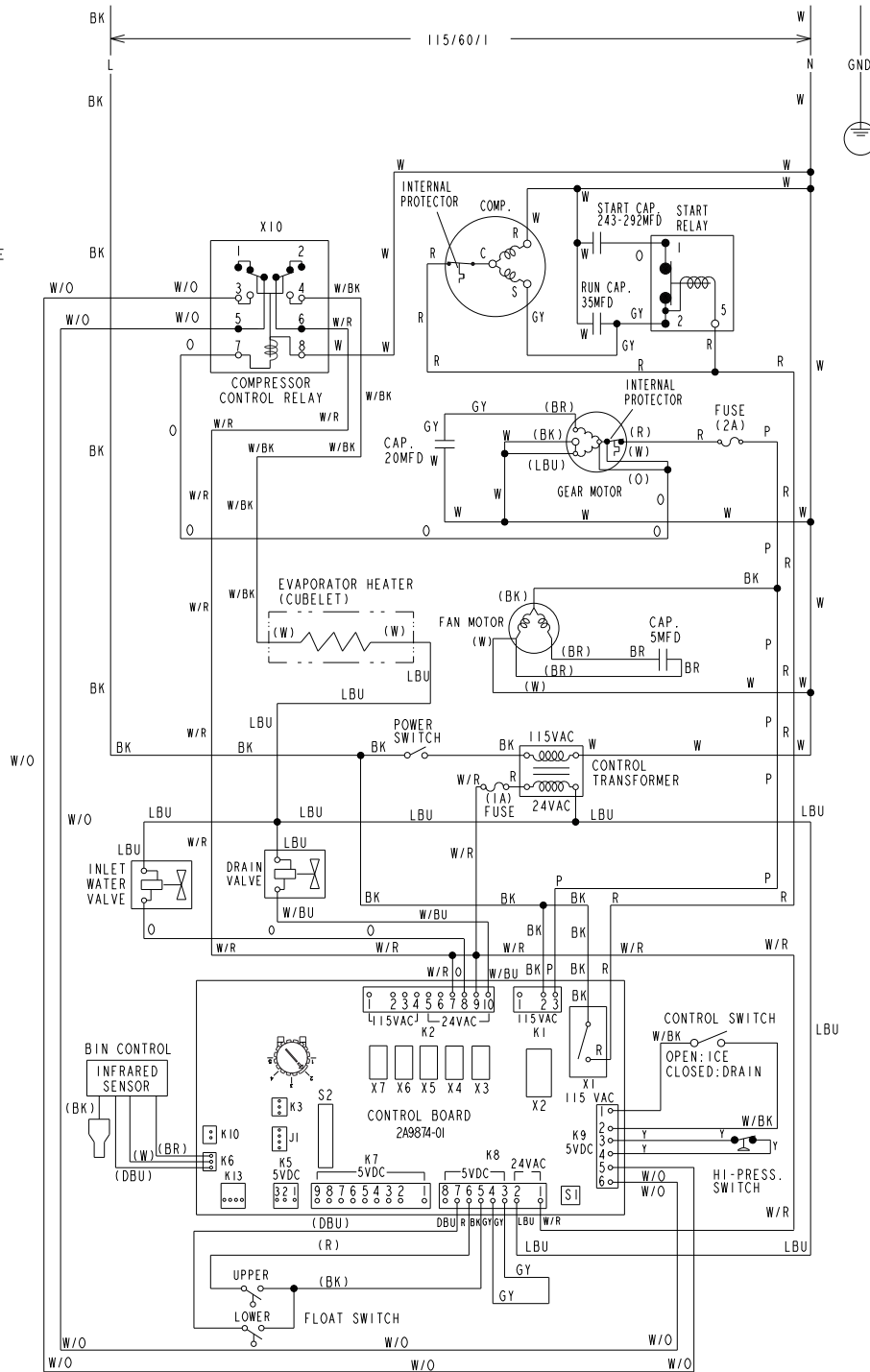

For S2 Dip Switch Settings
See "III.B.1. Default Dip Switch Settings"

b) N-3 Auxiliary Code and Later (Ultrasonic Bin Control 1)

S2 DIP SWITCH SETTING	1	2	3	4	5	6	7	8	9	10
F-450MAJ/-C	ON	OFF	OFF	OFF	OFF	OFF	ON	ON	OFF	OFF

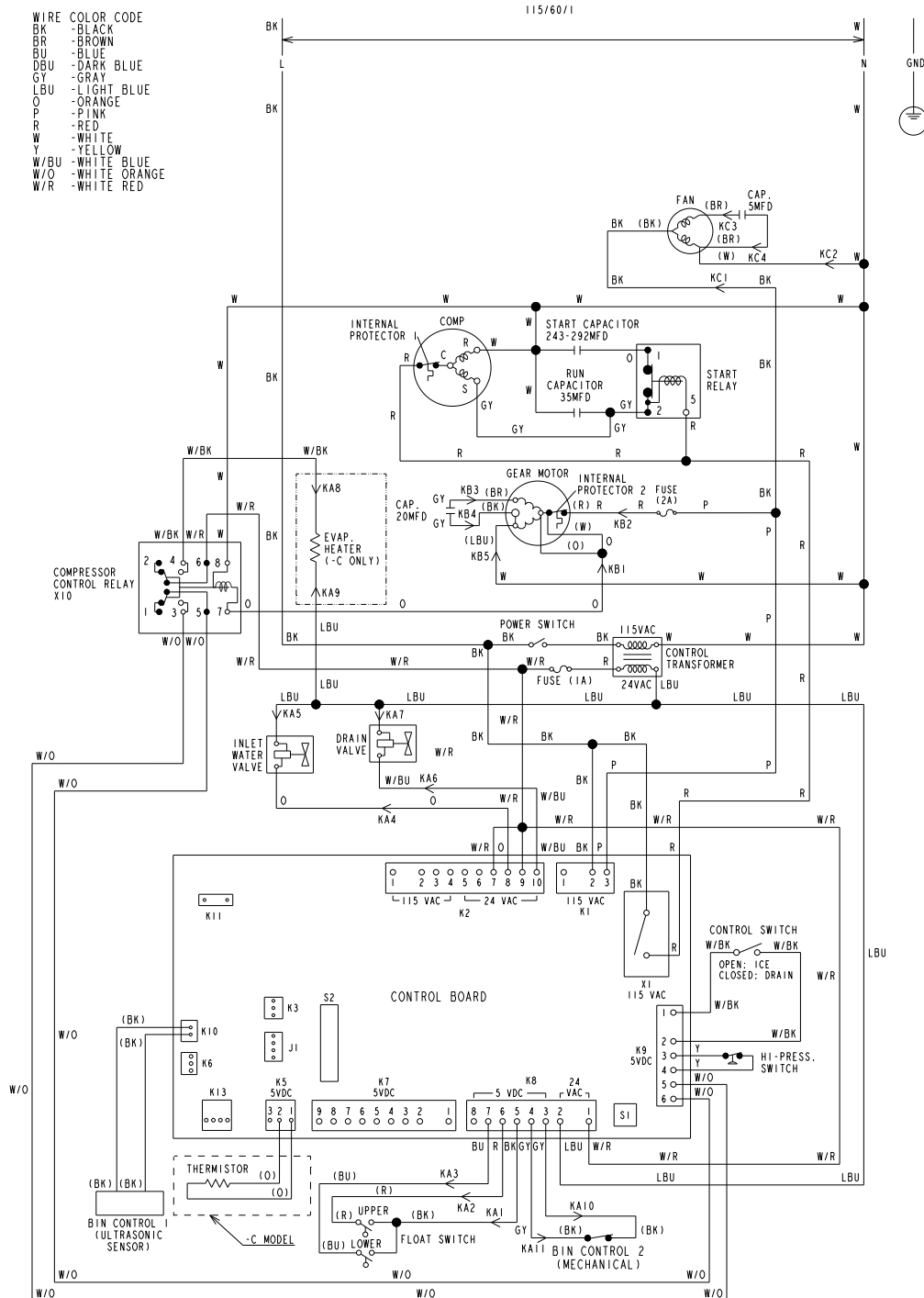

For S2 Dip Switch Settings
See "III.B.1. Default Dip Switch Settings"

2. F-801M_J(-C)

a) N-2 Auxiliary Code (Infrared Bin Control 1)

SI DIP SWITCH SETTING	1	2	3	4	5	6	7	8	9	10	
F-801M_J/-C	ON	OFF	OFF	OFF	OFF	OFF	OFF	ON	ON	OFF	OFF

WIRE COLOR CODE

BK	-BLACK
BR	-BROWN
BU	-BLUE
DBU	-DARK BLUE
GR	-GREEN
GY	-GRAY
LBU	-LIGHT BLUE
O	-ORANGE
P	-PINK
R	-RED
V	-VIOLET
W	-WHITE
Y	-YELLOW
W/BK	-WHITE BLACK
W/BR	-WHITE BROWN
W/BU	-WHITE BLUE
W/O	-WHITE ORANGE
W/R	-WHITE RED

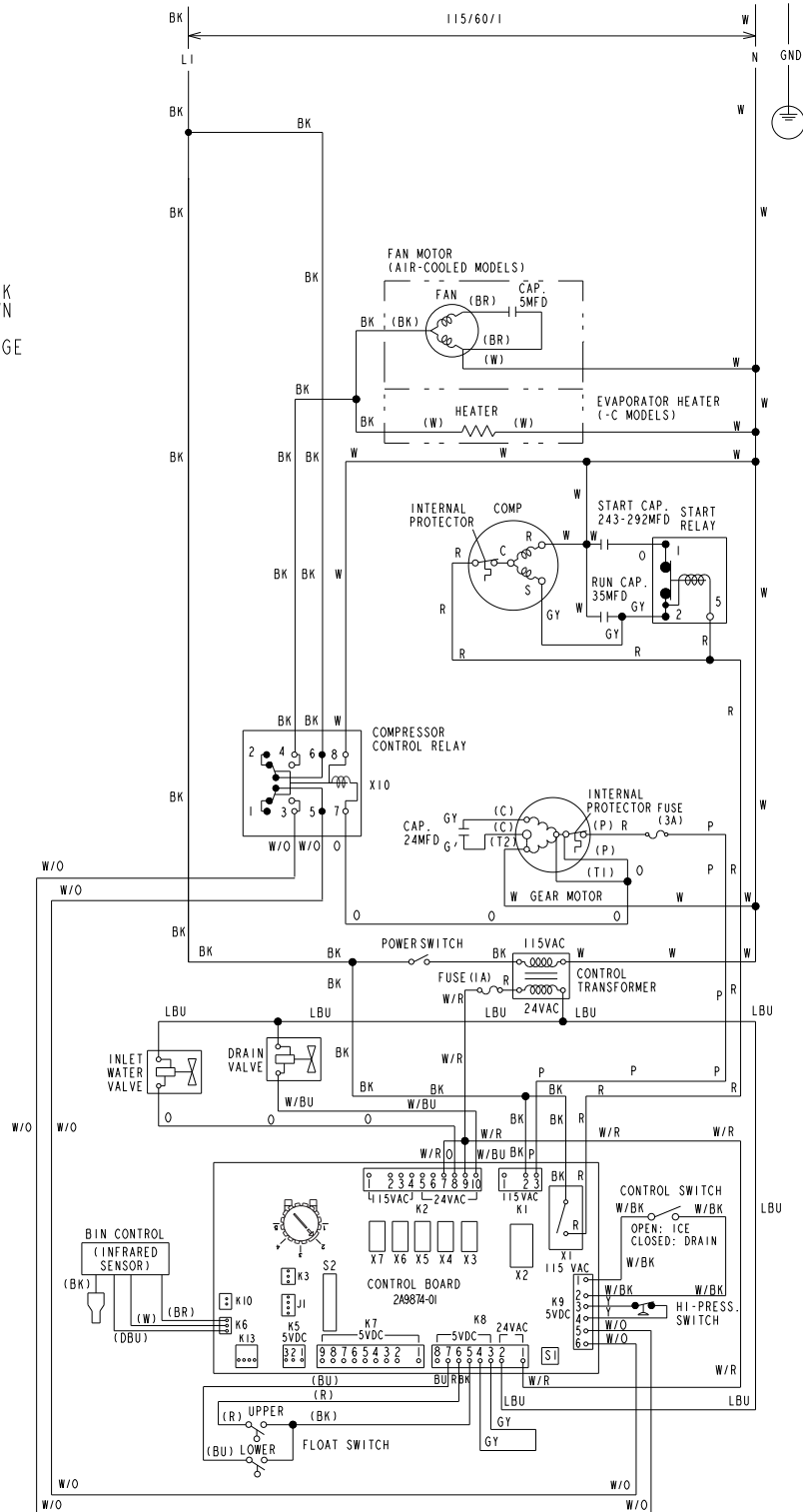

For S2 Dip Switch Settings
See "III.B.1. Default Dip Switch Settings"

b) N-3 Auxiliary Code and Later (Ultrasonic Bin Control 1)

S2 DIP SWITCH SETTING	1	2	3	4	5	6	7	8	9	10
F-801M_J/-C	ON	OFF	OFF	OFF	OFF	OFF	ON	ON	OFF	OFF

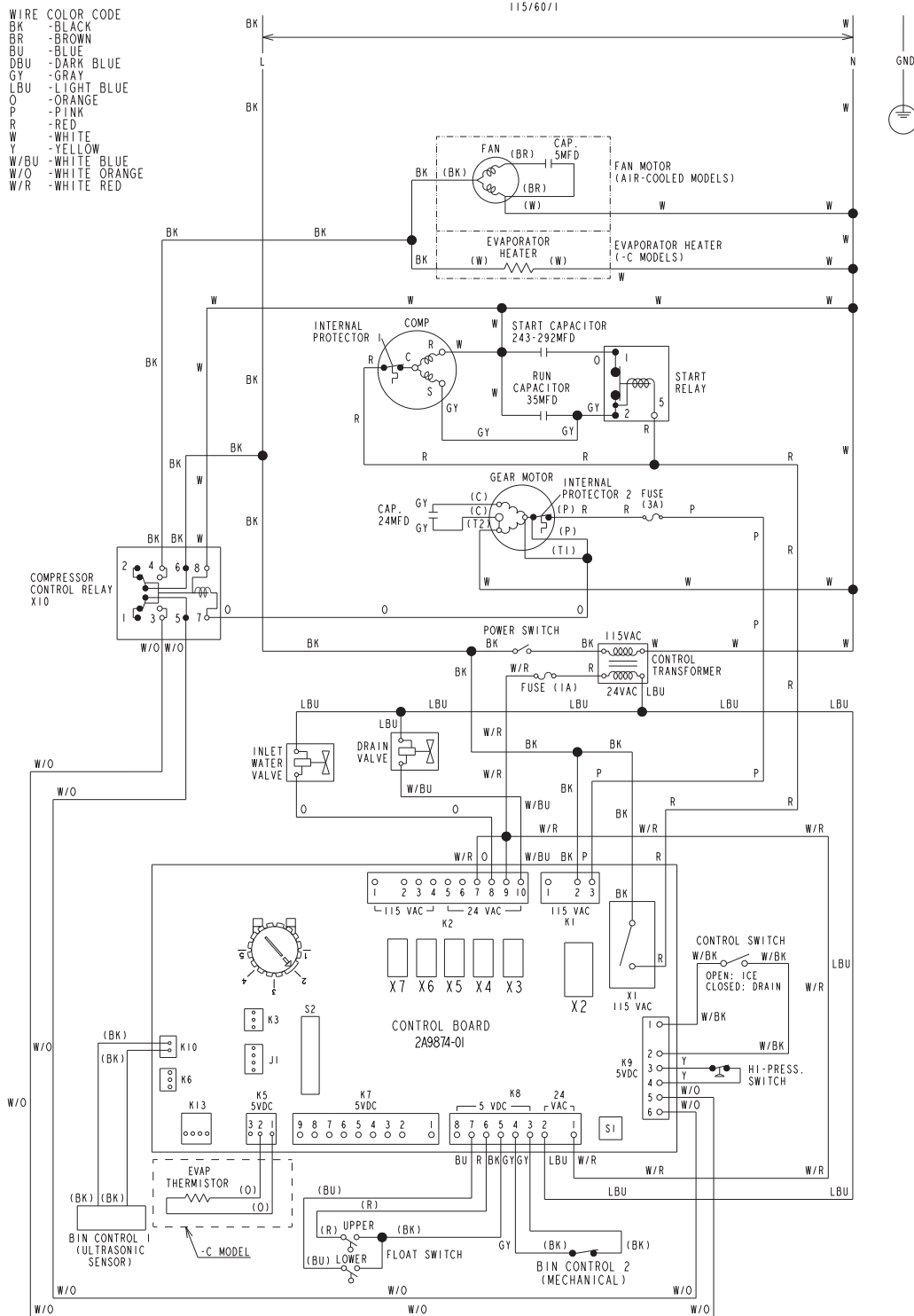

For S2 Dip Switch Settings
See "III.B.1. Default Dip Switch Settings"

3. F-1002MAJ(-C)(-SC), F-1002MWJ(-C), F-1002MRJ(Z)(-C)(-SC), F-1002MLJ

a) N-2 Auxiliary Code (Infrared Bin Control 1)

S2 DIP SWITCH SETTING	1	2	3	4	5	6	7	8	9	10
F-1002M_J(Z) / -C / -SC	ON	OFF	OFF	OFF	OFF	OFF	ON	ON	OFF	OFF

- WIRE COLOR CODE
- BK - BLACK
 - BR - BROWN
 - BU - BLUE
 - DBU - DARK BLUE
 - GR - GREEN
 - GY - GRAY
 - LBU - LIGHT BLUE
 - O - ORANGE
 - P - PINK
 - R - RED
 - V - VIOLET
 - W - WHITE
 - Y - YELLOW
 - W/BK - WHITE BLACK
 - W/BR - WHITE BROWN
 - W/BU - WHITE BLUE
 - W/O - WHITE ORANGE
 - W/R - WHITE RED

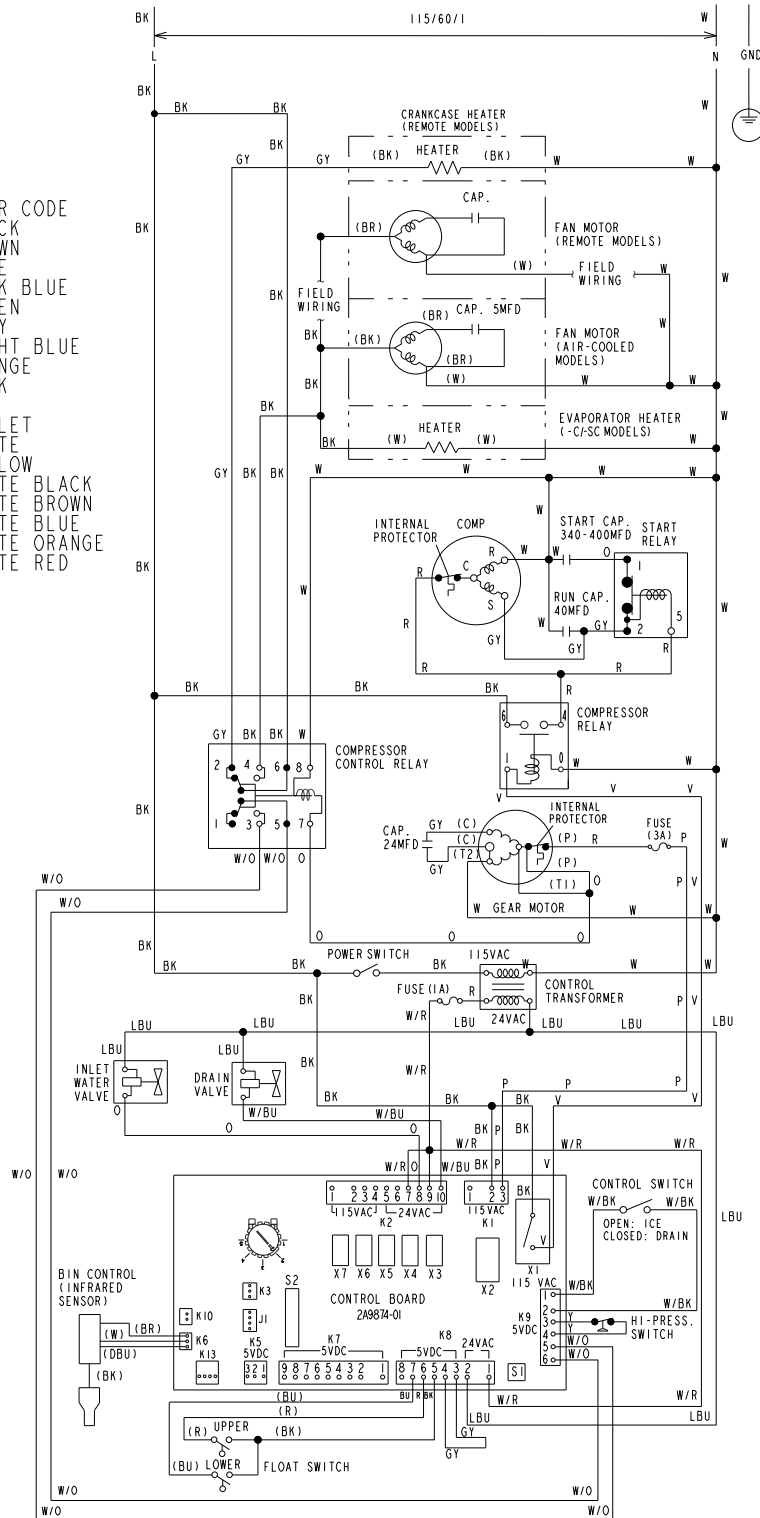

For S2 Dip Switch Settings
See "III.B.1. Default Dip Switch Settings"

b) N-3 Auxiliary Code and Later (Ultrasonic Bin Control 1)

S2 DIP SWITCH SETTING	1	2	3	4	5	6	7	8	9	10
F-1002M_Z(J)/-C/-SC	ON	OFF	OFF	OFF	OFF	OFF	ON	ON	OFF	OFF

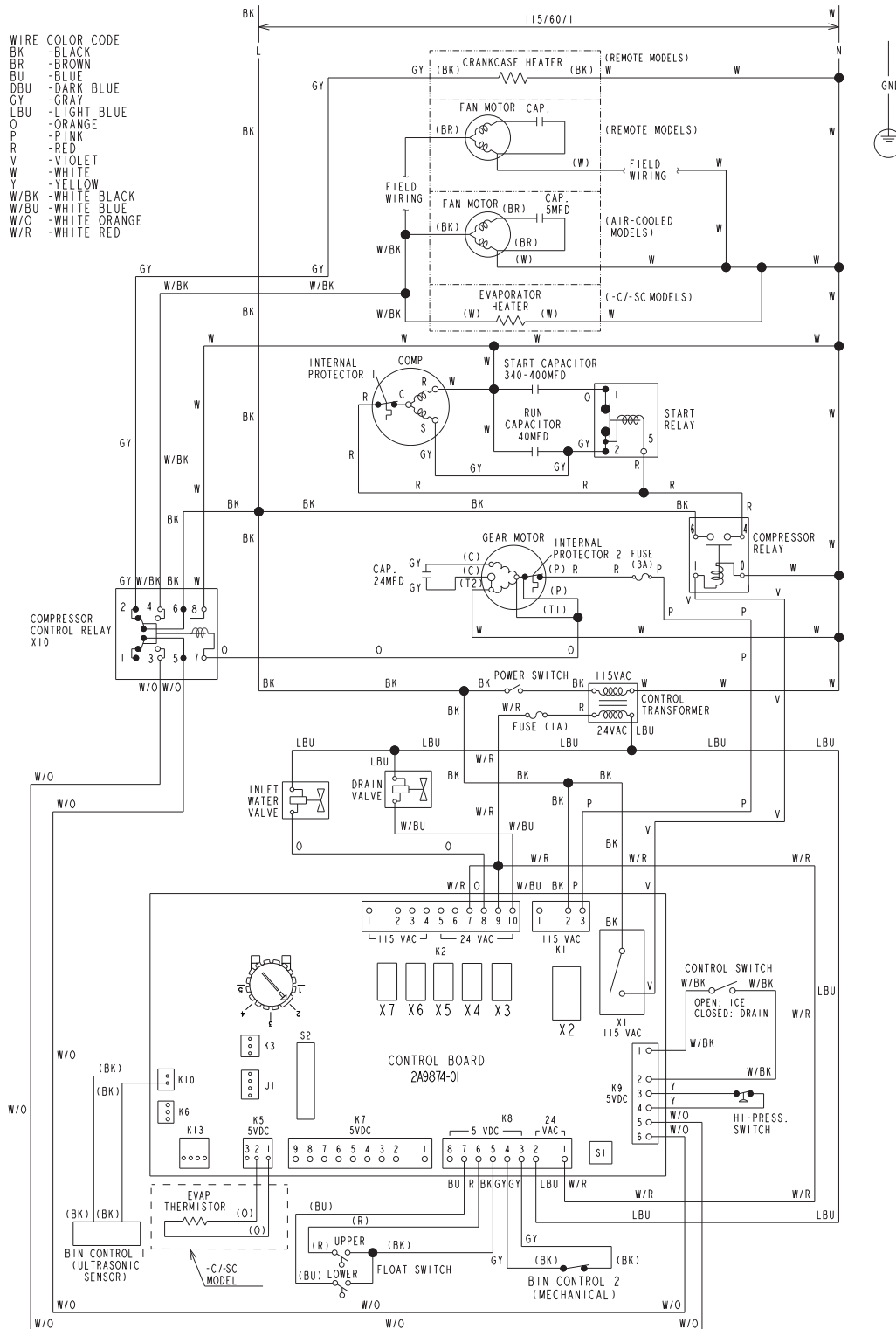

For S2 Dip Switch Settings
See "III.B.1. Default Dip Switch Settings"

4. FD-650M_J(Z)-(C)

a) N-3 Auxiliary Code and Later (Ultrasonic Bin Control 1)

S2 DIP SWITCH SETTING	1	2	3	4	5	6	7	8	9	10
FD-650M_J(Z)-C	ON	OFF	OFF	OFF	OFF	OFF	ON	ON	OFF	OFF

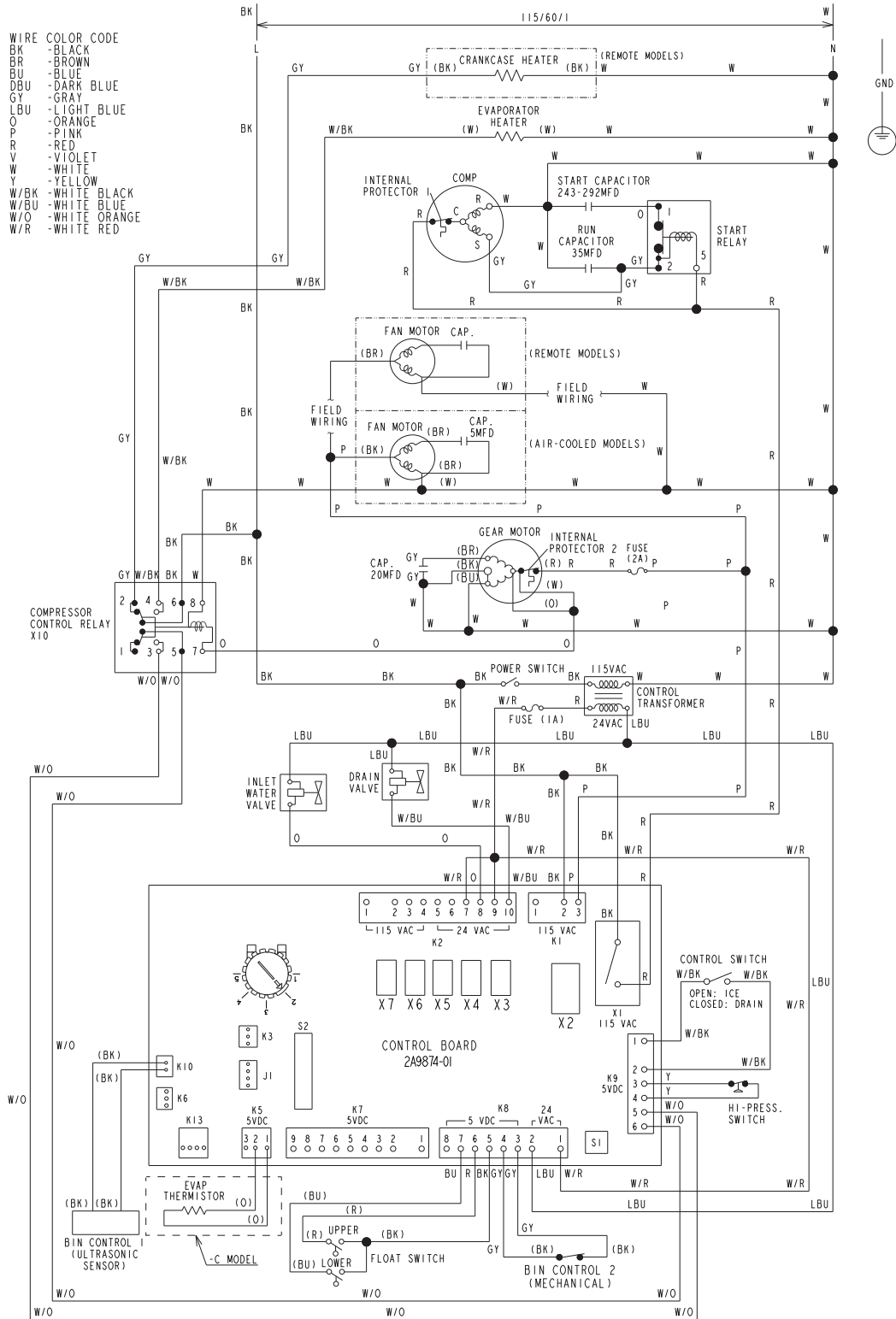

For S2 Dip Switch Settings
See "III.B.1. Default Dip Switch Settings"

5. FD-1002MAJ-C(-CB), FD-1002MRJZ-C(-CB)

a) N-3 Auxiliary Code and Later (Ultrasonic Bin Control 1)

S2 DIP SWITCH SETTING	1	2	3	4	5	6	7	8	9	10
FD-1002M_J(-C)/-CB	ON	OFF	OFF	OFF	OFF	OFF	ON	ON	OFF	OFF

