

ASSEMBLY INSTRUCTIONS

MODEL #

CM3256CH-AC-2PK

Questions?

GIVE US A CALL: 1-888-980-5122
MON-FRI 8:30AM - 5:30PM (PT)

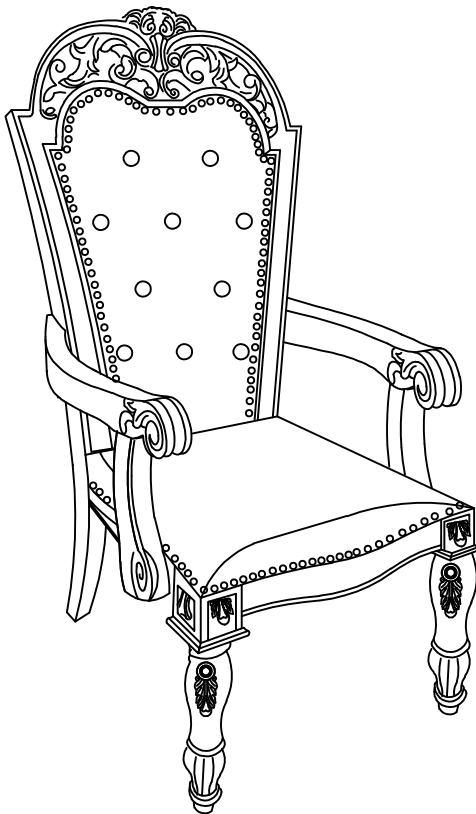

TOOLS REQUIRED



Allen Wrench

(Included)



Phillips Screwdriver

(Not Included)



2 - People
Recommended

ASSEMBLY RATING

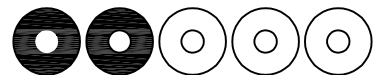

EASY → DIFFICULT

The Assembly Rating is a 5-point system showing the level of effort needed to assemble a specific product.



FOA Intro

Thank you for your purchase!

We hope you enjoy this new addition to your home for many years to come.

Our commitment to providing quality products does not simply end when you purchase our product. We fully stand behind our products from start to finish. Our customer service department is available Monday – Friday 8:30 AM – 5:30 PM Pacific and can help with assembly questions as well as, if necessary, replacing damaged or missing parts. To help expedite our service, please have these assembly instructions readily available, along with your order receipt.



Consumer Hotline
Toll-Free 1-888-980-5122



Monday to Friday
8:30AM- 5:30PM (PST)



WEBSITE
www.foagroup.com



E-MAIL
cs.ec@foagroup.com



foagroup



FurnitureOfAmerica



CHECK BEFORE STARTING



Are you missing anything?

Double-check all parts, hardware and accessories listed on Page 6 are accounted for.



Check out our Quick Tips!

We recommend reviewing the pre-assembly handouts. Even experts need a refresher now and then!



Should we send any replacements?

Are there any irregularities or flaws in the parts? We can send replacements!



Prep Time!

Please review the assembly instructions and all diagrams prior to assembling. Set up your workspace by laying the parts and hardware out separately, then begin!

PRE ASSEMBLY INTRODUCTION

We understand building ready-to-assemble furniture can be a challenging experience for some. To help avoid confusion, we have provided some helpful tips that may speed up the process.



Teamwork

ALWAYS have at least two people to help with transporting and assembling the product to avoid potential injury and/or damage.



Suitable Location

Assembling near the area of the intended location is highly recommended.



Sufficient Space

Make sure you have enough space to move around during the assembly.



Avoid Scratches

Use cardboard, blankets or a carpeted area while assembling furniture to prevent scratches.



Flat Surface

Make sure the furniture rests on a flat and level surface with each leg evenly touching the floor.

ASSEMBLY AND CARE ADVICE



FAILURE TO FOLLOW THE GUIDELINES BELOW MAY RESULT IN INJURY AND/OR PROPERTY DAMAGE.



Position each part correctly and insert screws or bolts into their respective holes.



Turn clockwise to tighten and only tighten when step is completed or when instructed to do so.



Use the appropriate hand tools or power tools for assembly. Select steps, such as tightening screws and/or bolts, may require hand tools to avoid causing damage during assembly.



Save the instructions and store any supplied tools for later maintenance.



After two weeks, check and tighten any loose hardware and repeat again every six months thereafter.

IT IS THE USER'S RESPONSIBILITY TO MAINTAIN THE FURNITURE. THE HARDWARE MAY LOOSEN OVER TIME AND MAY CAUSE THE FURNITURE TO BE WOBBLY AND UNABLE TO SUPPORT ITS INTENDED WEIGHT CAPACITY. THIS MAY LEAD TO COLLAPSE AND MAY CAUSE SERIOUS INJURY.

ARM CHAIR

CM3256-AC-2PK



- Please keep instructions for future reference.
- Check the quantity and irregularity of parts and hardware before you start.

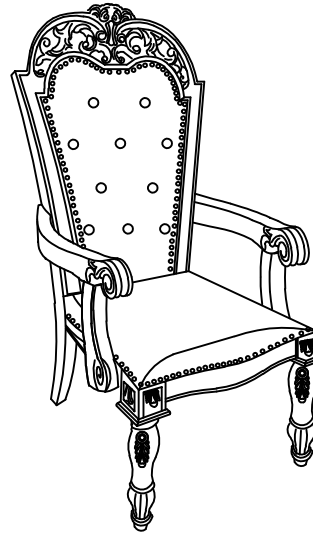

PARTS

#1 1pc x2

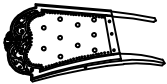

Chair Back

#2 1pc x2

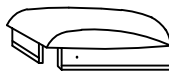

Chair Seat

#3 2pcs x2

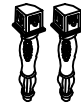

Legs

#4 2pcs x2

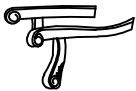

Arm (L&R)

HARDWARE

#A 4pcs x2



Bolt
Ø5/16" x 3-1/4"

#B 4pcs x2



Bolt
Ø5/16" x 2-1/4"

#C 3pcs x2



Bolt
Ø5/16" x 1-3/4"

#D 11pcs x2



Lock Washer
Ø5/16"

#E 11pc x2



Flat Washer
Ø5/16"x22mm

#F 1pc x2



Allen Wrench M4

#G 2pcs x2



Screw
#8 x 50mm

Exploded View

x 2

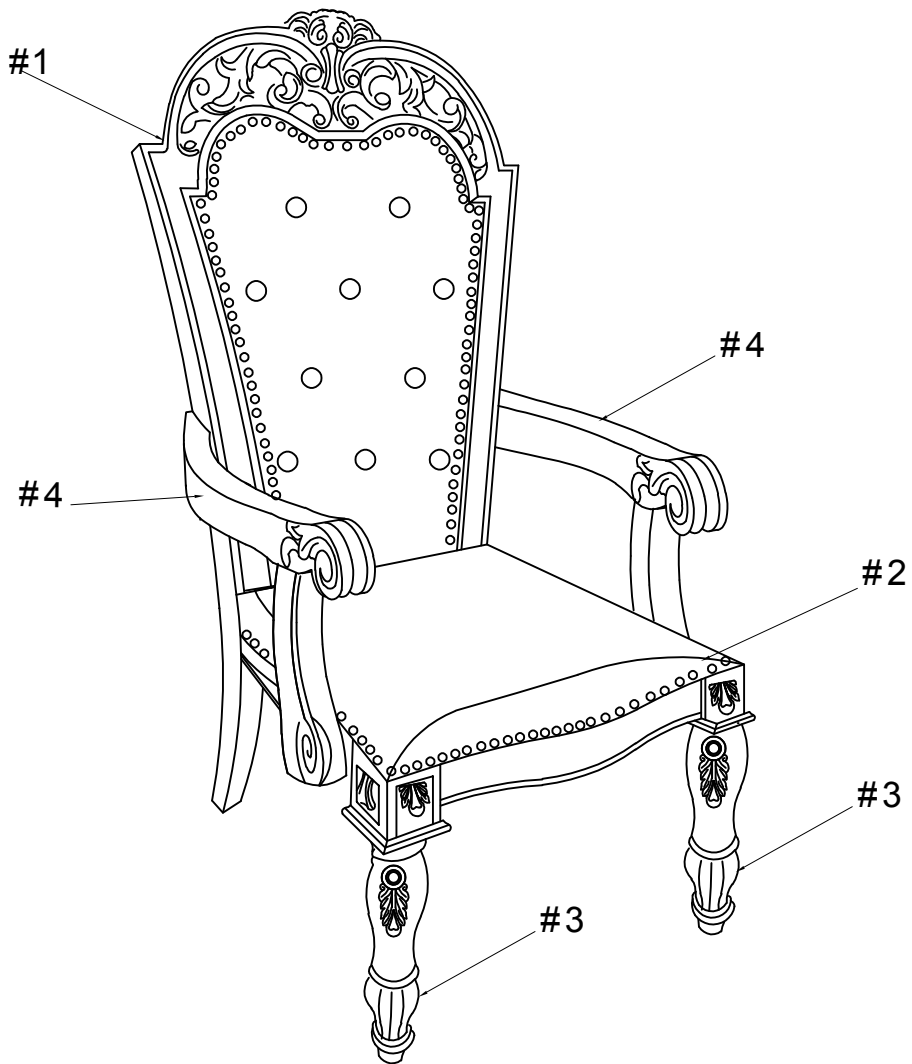

ASSEMBLY INSTRUCTIONS

1

- Part (#2) x1pc
- Part (#3) x2pc
- Hardware (#B) x4pcs
- Hardware (#D) x4pcs
- Hardware (#E) x4pcs

Align the Leg (#3) to the Chair Seat (#2) and secure by using Bolt (#B) with Lock Washer (#D) and Flat washer (#E).

x2

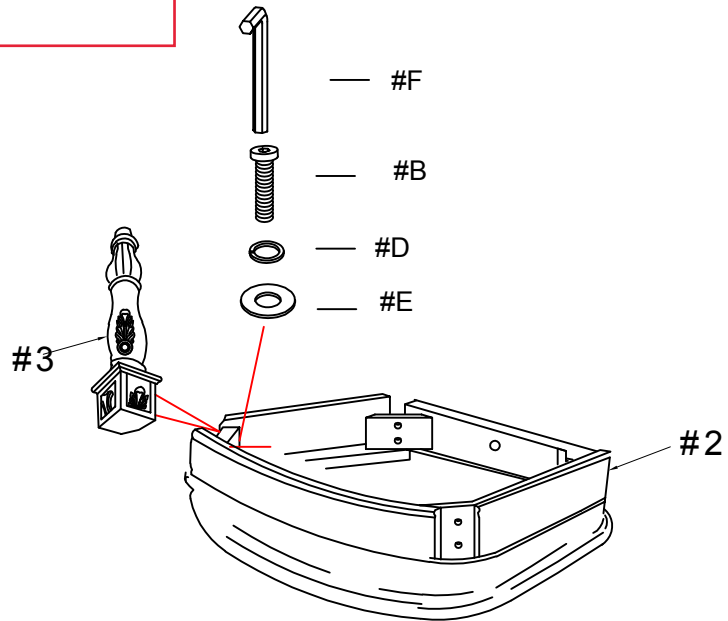

2

- Hardware (#C) x1pc
- Hardware (#D) x1pc
- Hardware (#E) x1pc

Align the Chair back (#1) to the Chair Seat (#2). Secure at the center of the seat by using Bolt (#C) with Lock washer (#D) and Flat washer (#E).

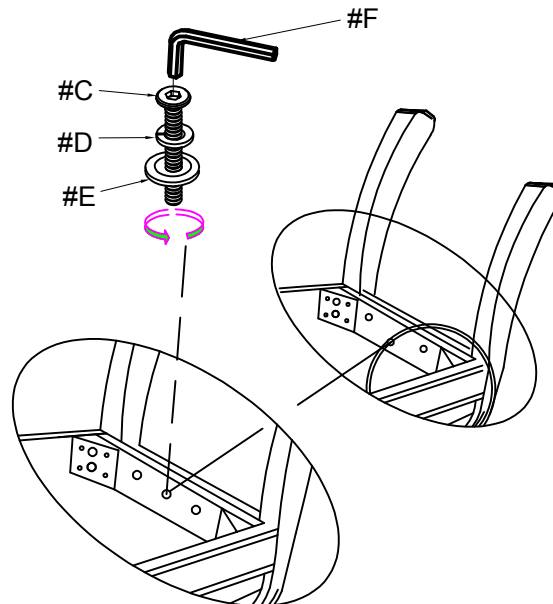

ASSEMBLY INSTRUCTIONS

Secure the Chair Back (#1) to the Chair seat (#2) at the corners by using Bolt (#A) with Lock washer (#D) and Flat washer (#E).

3

- Hardware #A x4pcs
- Hardware #D x4pcs
- Hardware #E x4pcs

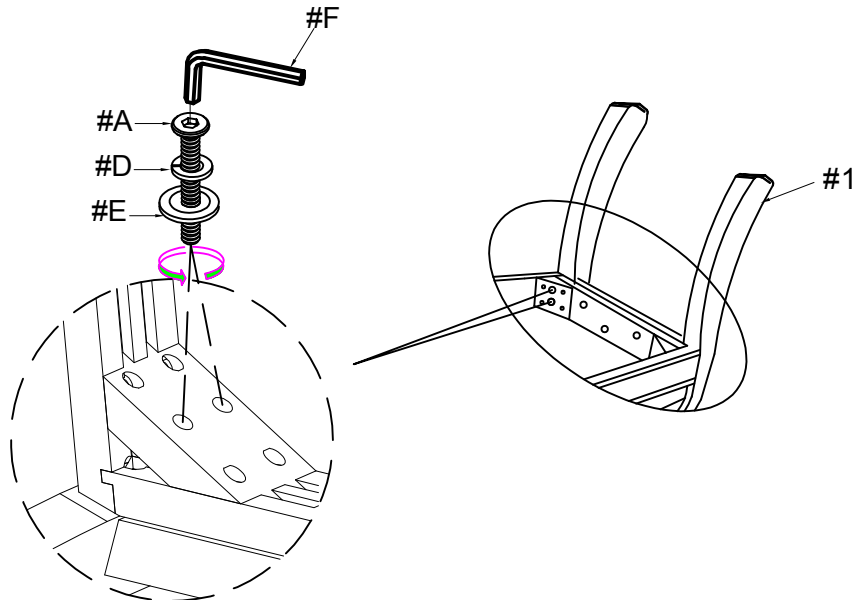

4

- Part #4 x2pcs
- Hardware #C x2pcs
- Hardware #D x2pcs
- Hardware #E x2pcs

Align the Arm (#3) to the Chair Back (#1) and Chair seat (#2). Use Bolts (#C) with Lock Washer (#D) and Flat washer (#E) to secure at the seat.

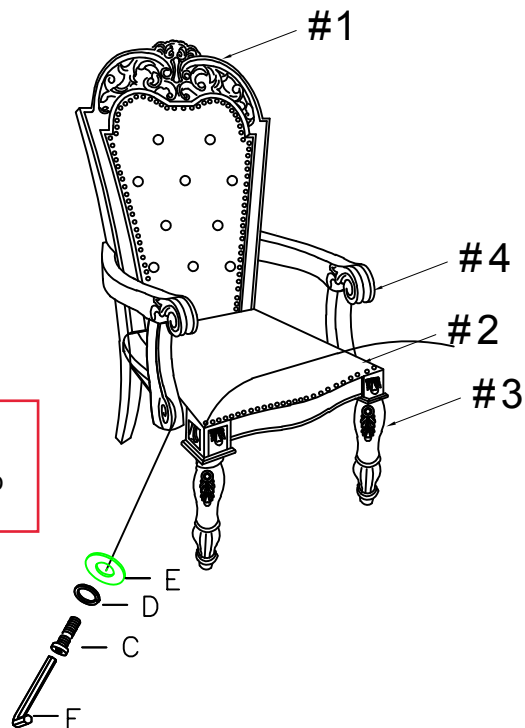

ASSEMBLY INSTRUCTIONS

5

Use Screw (#G) to secure the top of the arms to the Chair back (#1).

HARDWARE #G x 2pcs

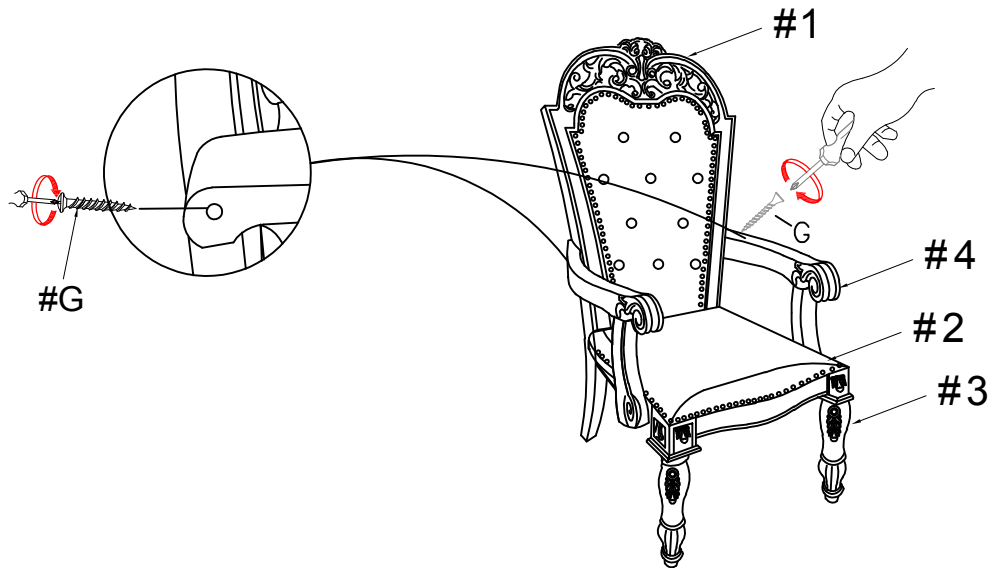

6

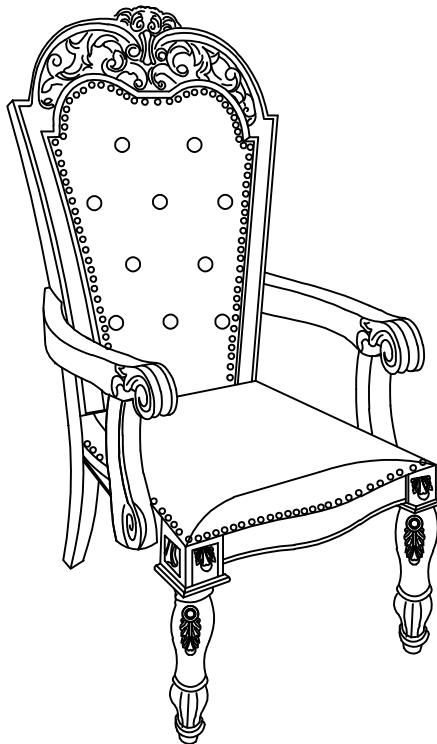

ASSEMBLY COMPLETED



Please ensure the furniture rests on an even and flat surface. If the product wobbles or feels loose, double-check all bolts and/or screws are properly tightened and secured.

✓ **Keep this handy!**

Please retain this instruction manual and any order-related information for future reference.

✓ **Lift, don't drag!**

To avoid damage to product please always LIFT the product when transporting or adjusting the placement.