

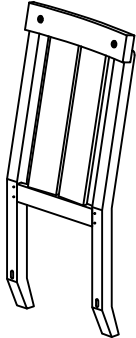

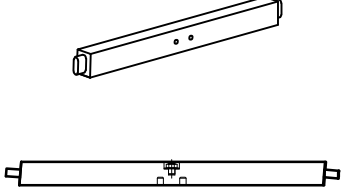

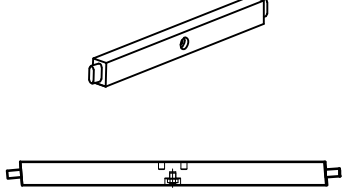

YOSEMITE WOOD BACK CHAIR ASSEMBLY INSTRUCTIONS

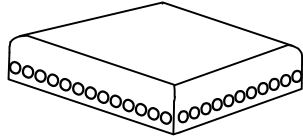
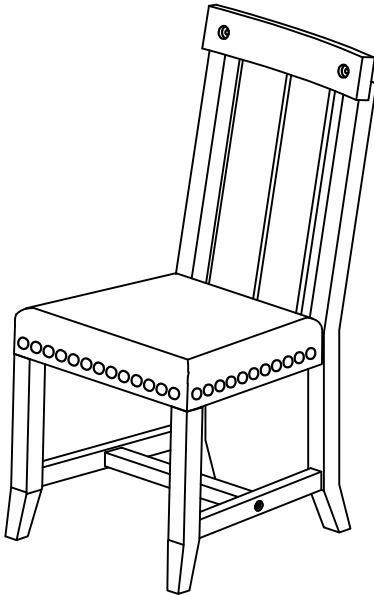
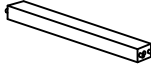
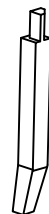
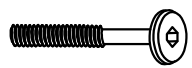

<p>A. CHAIR BACK 1 PC</p> 	<p>F. LEFT STRETCHER 1 PC</p> 	<p>G. RIGHT STRETCHER 1 PC</p> 
<p>B. CHAIR SEAT 1 PC</p> 	<p>YOSEMITE WOOD BACK CHAIR ASSEMBLED</p> 	
<p>C. CENTER STRETCHER 1 PC</p> 		
<p>D. LEFT LEG 1 PC</p> 		

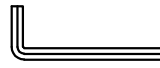
HARDWARE PACKED IN BOX

<p>1 ALLEN BOLT (M6X50) 04 PCS</p>	<p>2 ALLEN BOLT (M6X70) 04 PCS</p>	<p>3 SPRING WASHER (M9) 08 PCS</p>	<p>4 FLAT WASHER (M9) 08 PCS</p>	<p>5 ALLEN KEY 01 PC</p>
				
<p>6 WOOD SCREW (M4X40) 06 PCS</p>				
				

TOOL REQUIRED

PHILIPS HEAD SCREW DRIVER
(NOT PROVIDED)

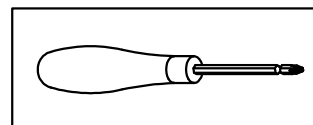

STEP 1:

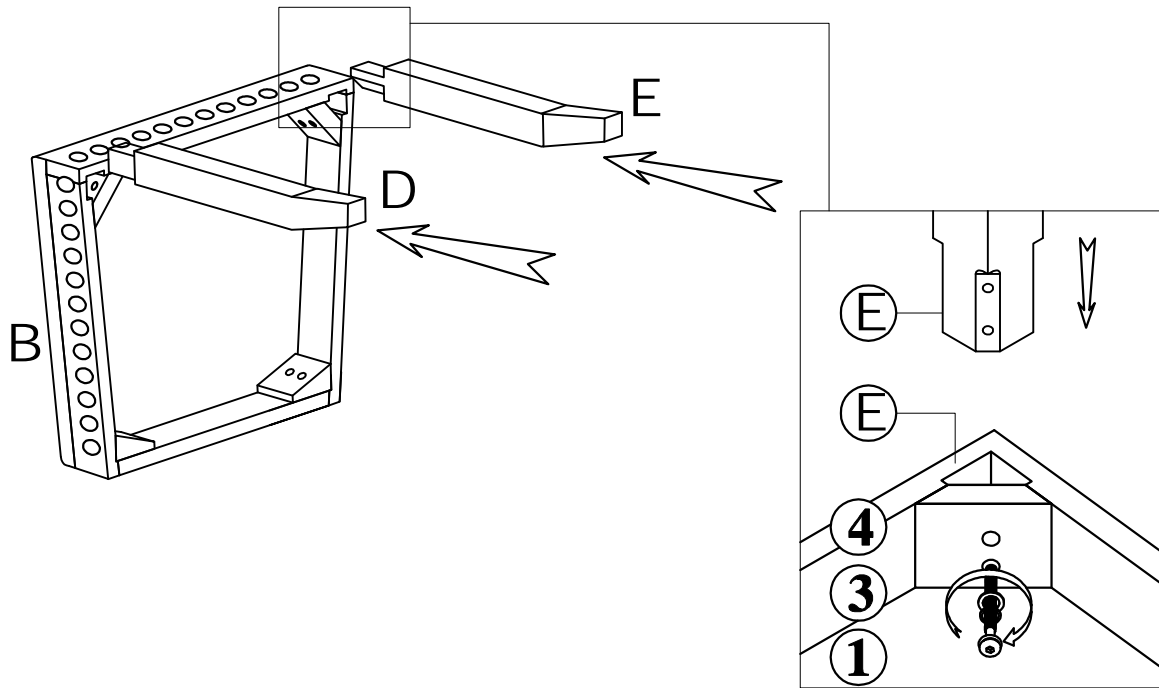

NOTE:
DO NOT COMPLETELY TIGHTEN BOLTS, ONLY FINGER TIGHTEN

STEP 2:

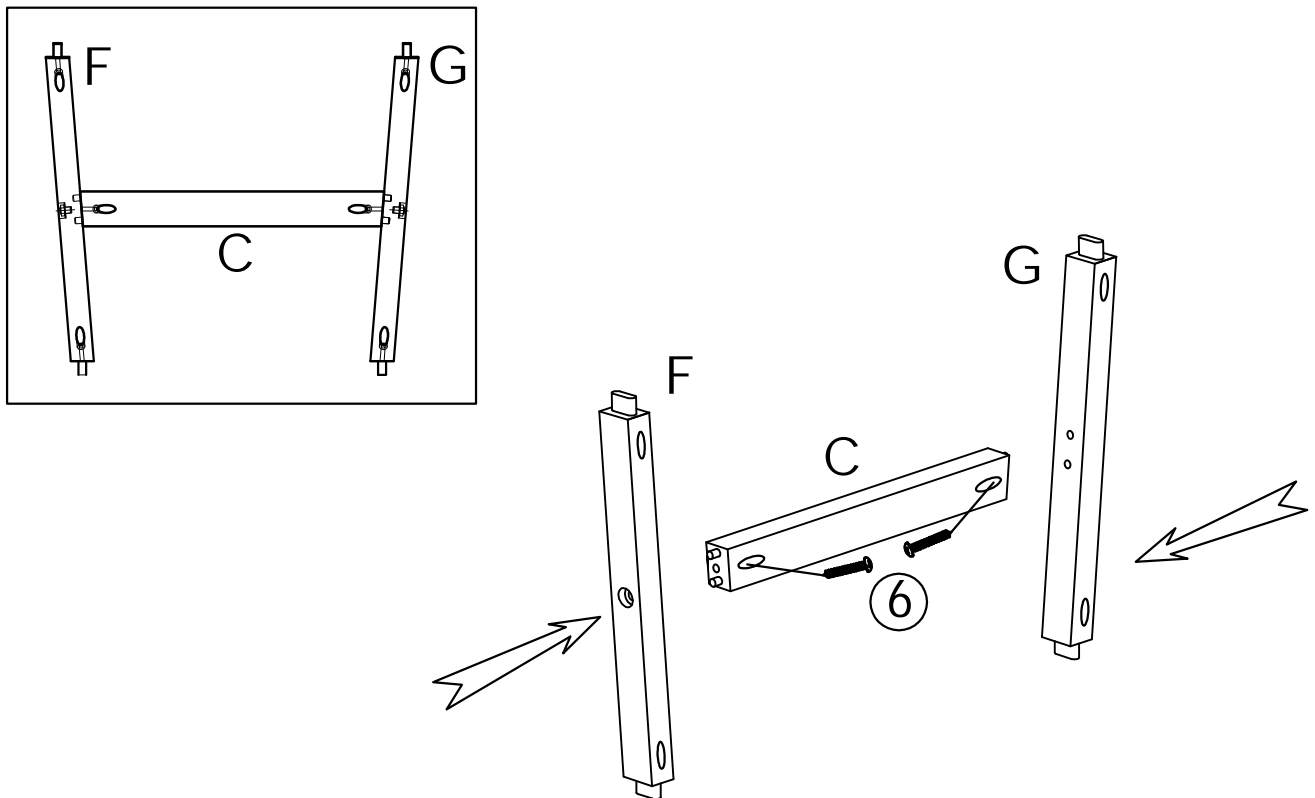

STEP 3:

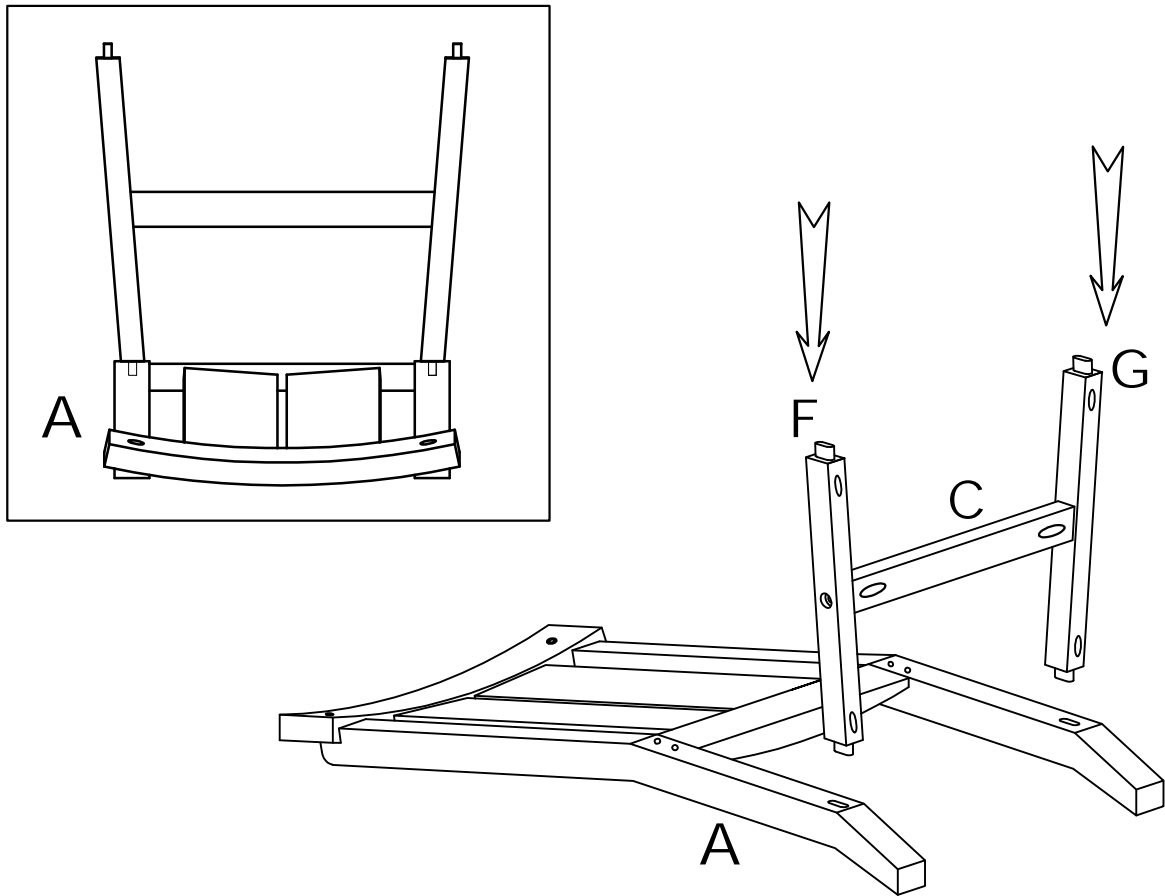

STEP 4:

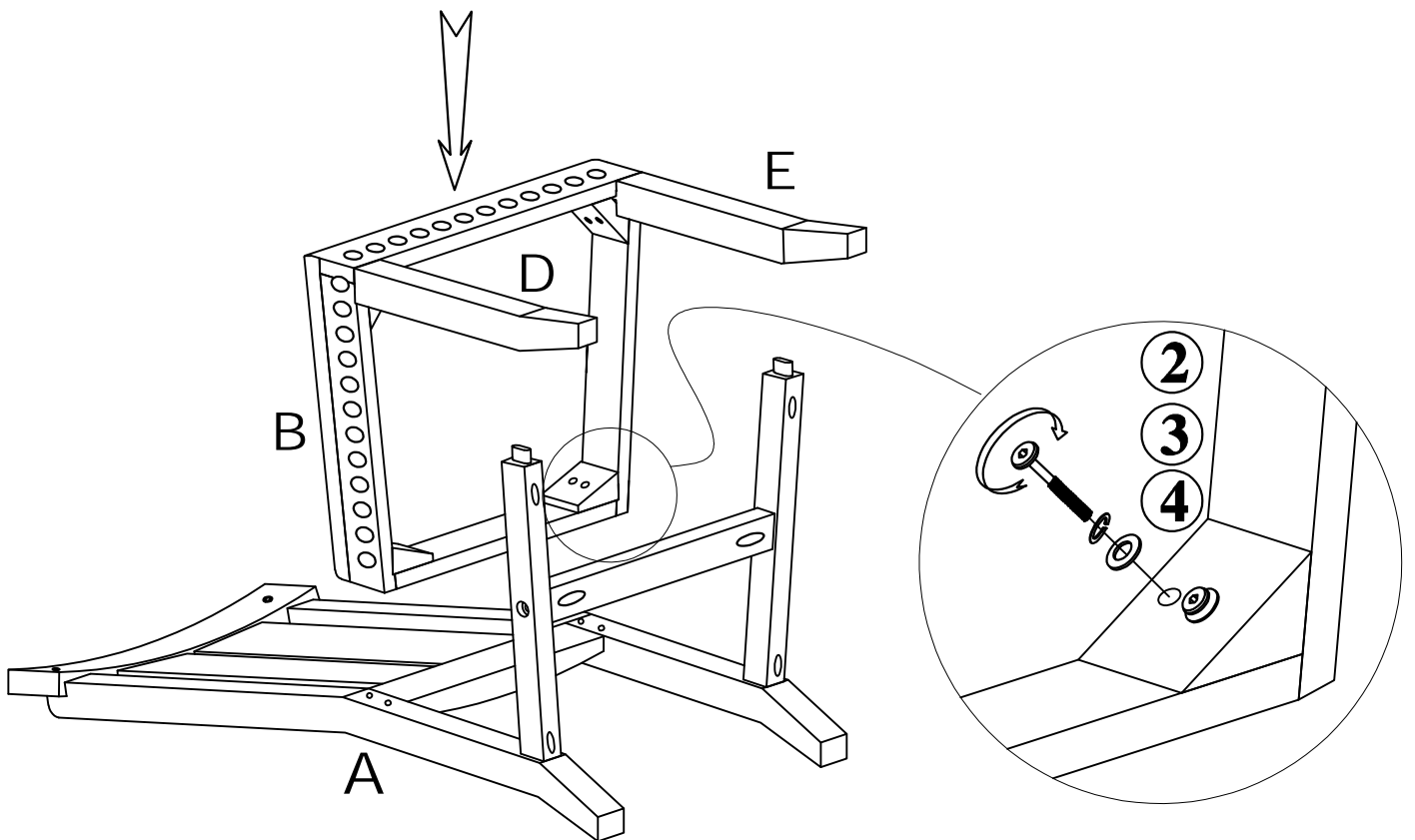

STEP 5:

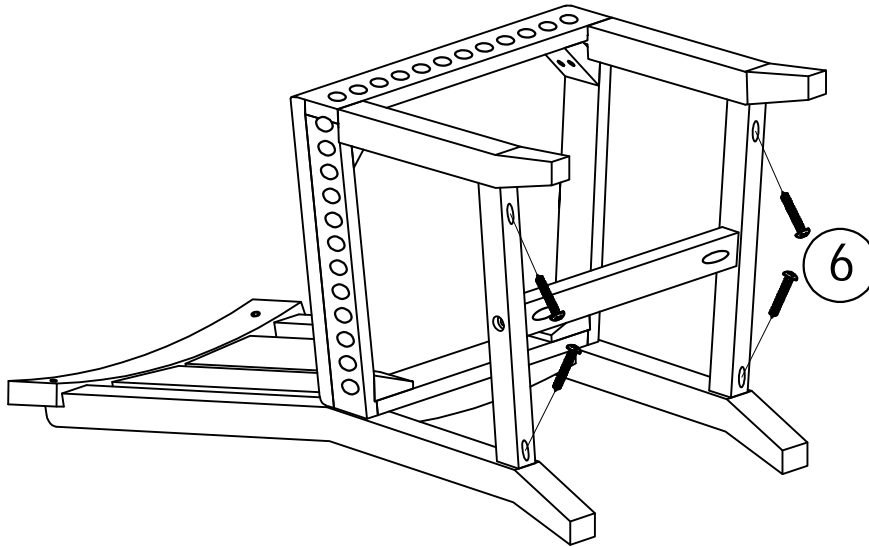

STEP 6:

PLACE THE CHAIR ON A FLAT, LEVEL AREA AND LEVEL THE CHAIR BY MAKING SURE ALL LEGS COME IN CONTACT WITH THE FLOOR. AFTER LEVELLING, WITHOUT CHANGING THE ORIENTATION OF THE CHAIR, TIGHTEN ALL THE BOLTS ON THE UNDERSIDE OF THE CHAIR WITH THE PROVIDED ALLEN KEY.

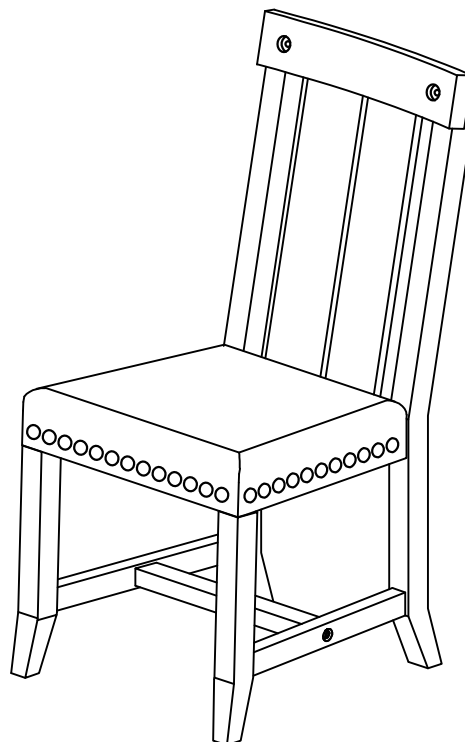

ASSEMBLY COMPLETE.