

Assembly Instructions

CM7129Q

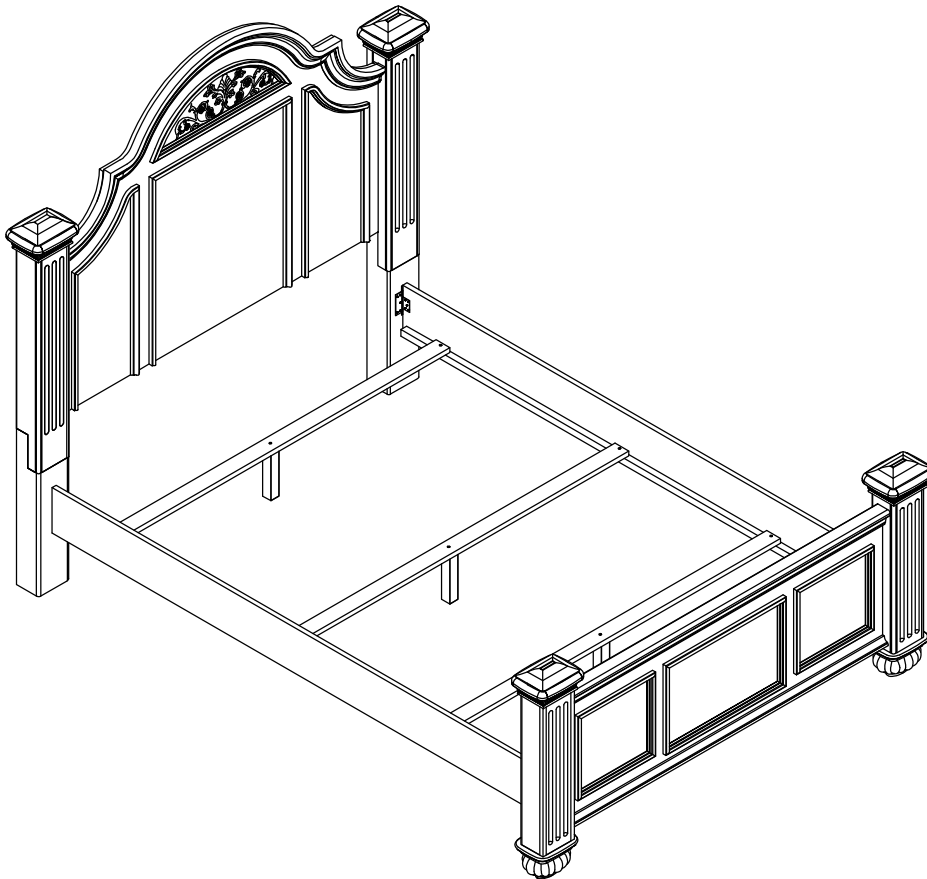

ASSEMBLY RATING

The Assembly Rating is a 5-point system that shows the degree of effort needed in assembling a specific product (with 1 being easy and 5 being difficult). For some products, two persons are recommended.

EASY  DIFFICULT

Tools Required For Assembly:

Allen Wrench

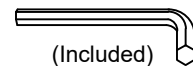

Phillips Screwdriver

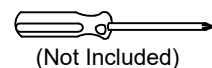

2 PERSONS RECOMMENDED

ASSEMBLY & CARE ADVICE

FOR YOUR FURNITURE TO LAST, CORRECT ASSEMBLY AND PROPER MAINTENANCE ARE NECESSARY. PLEASE FOLLOW THE INFORMATION PROVIDED BELOW TO FULLY ENJOY YOUR FURNITURE.

BASIC ASSEMBLY TECHNIQUES

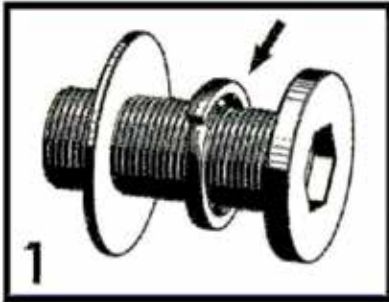

1
When lock or spring washer is used in an assembly, please make sure the lock or spring washer is placed between the larger flat washer and the head of the screw or bolt.

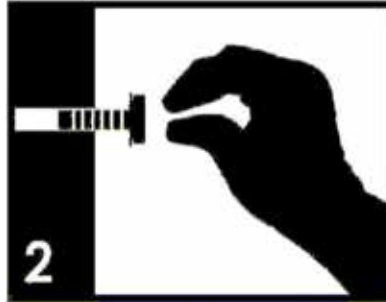

2
Position each part correctly and insert screws or bolts into their respective holes by hand tighten or using the proper hand tool. Only tighten when step is completed or when instructed to do so.

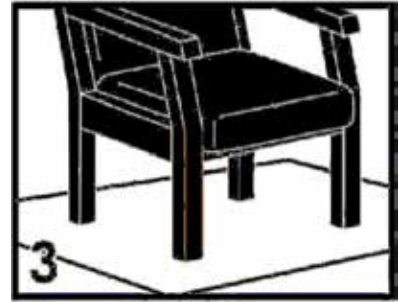

3
Use cardboard or carpet area when assembling furniture to prevent scratches. Make sure the furniture rests on a flat and level surface with each leg evenly touching the floor.

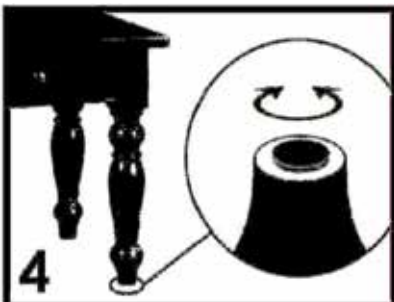

4
Some furniture comes with height adjustment knobs underneath each leg. To lower or to raise each leg, you need to turn clockwise or counterclockwise, respectively.

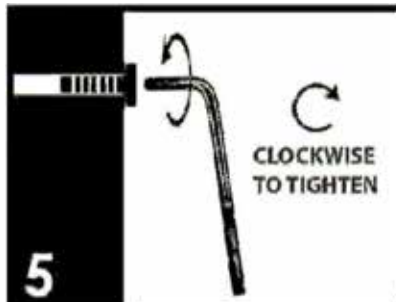

5
Make sure all parts are properly aligned, then use the appropriate hand tool to completely tighten the bolts or screws. Do not use power tools and do not overtighten.



6
Save the instructions and store the Allen wrench or any supplied tool for later maintenance. After two weeks, check and tighten any loose hardware and repeat again every six months thereafter.

IT IS THE USER'S RESPONSIBILITY TO MAINTAIN THE FURNITURE. THE HARDWARE MAY LOOSEN OVER TIME AND MAY CAUSE THE FURNITURE TO BE WOBBLY AND UNABLE TO SUPPORT ITS INTENDED WEIGHT CAPACITY. THIS MAY LEAD TO COLLAPSE AND MAY CAUSE SERIOUS INJURY.



FAILURE TO FOLLOW THE GUIDELINES ABOVE MAY RESULT IN INJURY AND/OR PROPERTY DAMAGE.



Before you begin, please read Page 2 of "Assembly and Care Advice".

And remember, do not tighten until each step is completed or instructed.

MD

Parts List

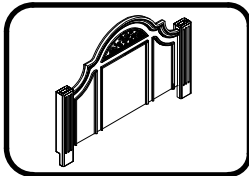

#1 x 1 pc
Headboard

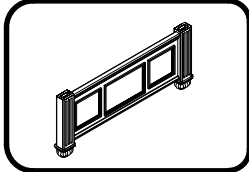

#2 x 1 pc
Footboard

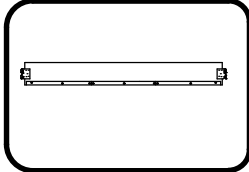

#3 x 2 pcs
Side Rail

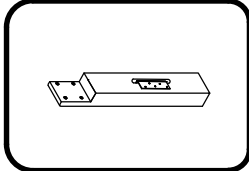

#4 x 2 pcs
Leg (L&R)

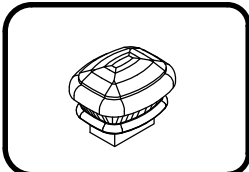

#5 x 4 pcs
Finial

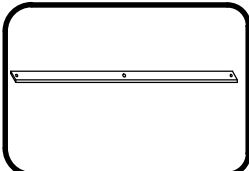

#6 x 3 pcs
Slat

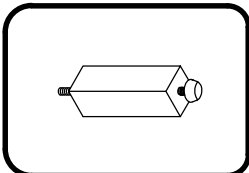

#7 x 3 pcs $\text{\O}1/4"$
Slat Support 35x35x190mm

Hardware List

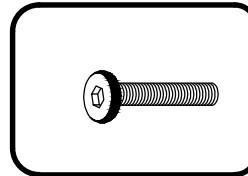

#A x 8 pcs
Bolt $\text{\O}1/4"$ x 2-1/2"



#B x 8 pcs
Lock Washer $\text{\O}1/4"$



#C x 8 pcs
Flat Washer $\text{\O}1/4"$

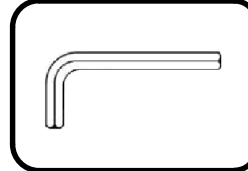

#D x 1 pc
Allen Wrench M4



#E x 4 pcs
Long Screw #4x1-3/8"

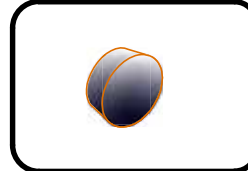

#Fx 2 pcs
Cover



#G x 6 pcs
Short Screw #4x1-3/16"



MD

Before you begin, please read Page 2 of "Assembly and Care Advice".

And remember, do not tighten until each step is completed or instructed.



#A x 8 pcs
#B x 8 pcs
#C x 8 pcs

- I. Align the right headboard leg (#4R) with the right side of the headboard (#1).
- II. Prepare 8 bolt assemblies by inserting FIRST the lock washer (#B) onto the bolt (#A) and then the flat washer (#C) onto the SAME bolt (#A), in that order.
- III. Insert the bolt assemblies through the right headboard leg (#4R) and secure those bolts using the Allen wrench (#D) to lock them in with the headboard (#1).
- IV. Repeat process above to assemble the left headboard leg (#4L) onto the left side of the headboard (#1).

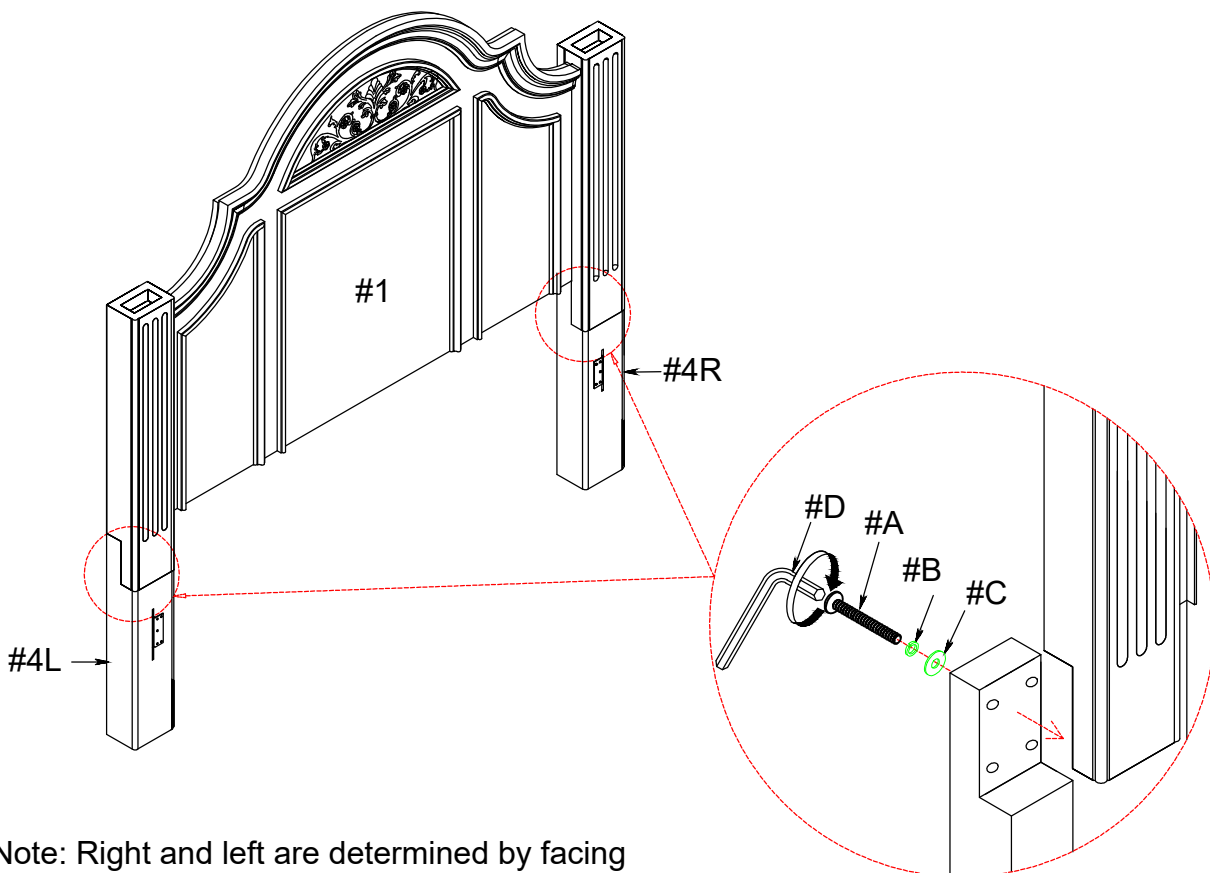

Note: Right and left are determined by facing the front of the bed in upright position.

Turn right (clockwise) to tighten



#E x 4 pcs
#F x 2 pcs

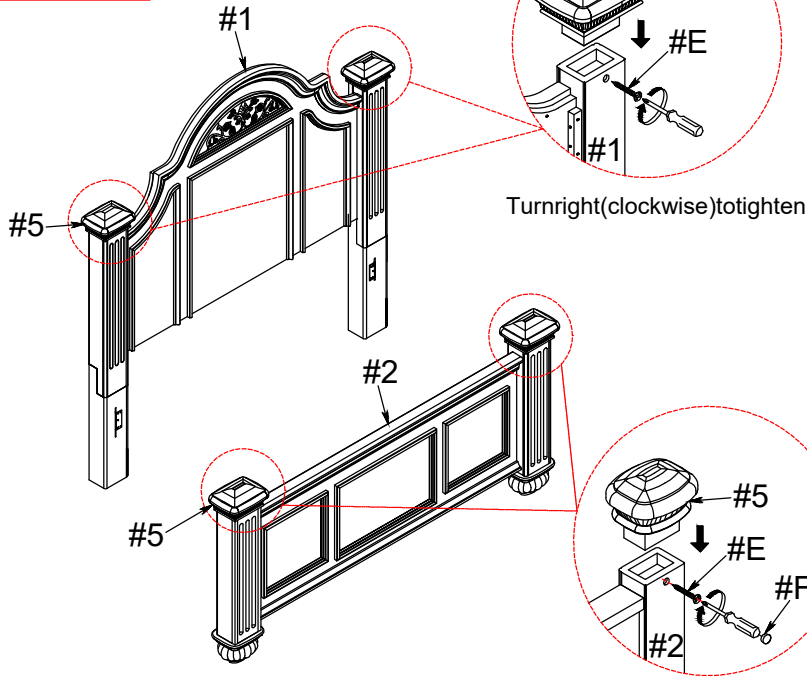

- I. Align the 2 finials (#5) onto the top of the headboard (#1).
- II. Secure two long screws (#E) through the holes on the headboard (#1) using a Phillips screwdriver to tighten them down to the 2 finials (#5).
- III. Align the other 2 finials (#5) onto the top of the footboard (#2).
- IV. Secure two long screws (#E) through the holes on the footboard (#2) using a Phillips screwdriver to tighten them down to the 2 finials (#5). Then place the 2 covers (#F) over the 2 long screws (#E) on the footboard (#2) to cover the holes.

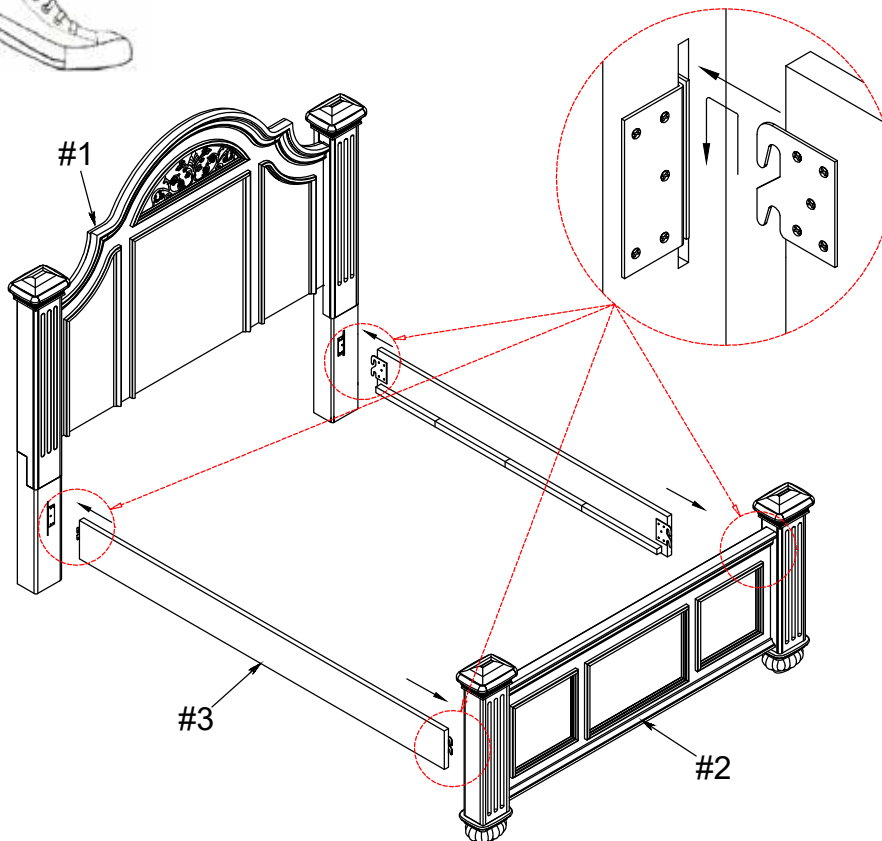

- I. Insert the hooks of the 2 side rails (#3) into the slotted bars of the headboard (#1). Make sure both parts are secured properly.
- II. Insert the hooks of the other ends of the two side rail (#3) into the slotted bars of the footboard (#2). Make sure both parts are secured properly.



Align the threaded end of the slat support leg (#7) with the pre-drilled holes of the slat (#6) and tighten by hand until secured. Repeat the process for the remaining 2 slat support legs (#7) onto the 2 slats (#6).

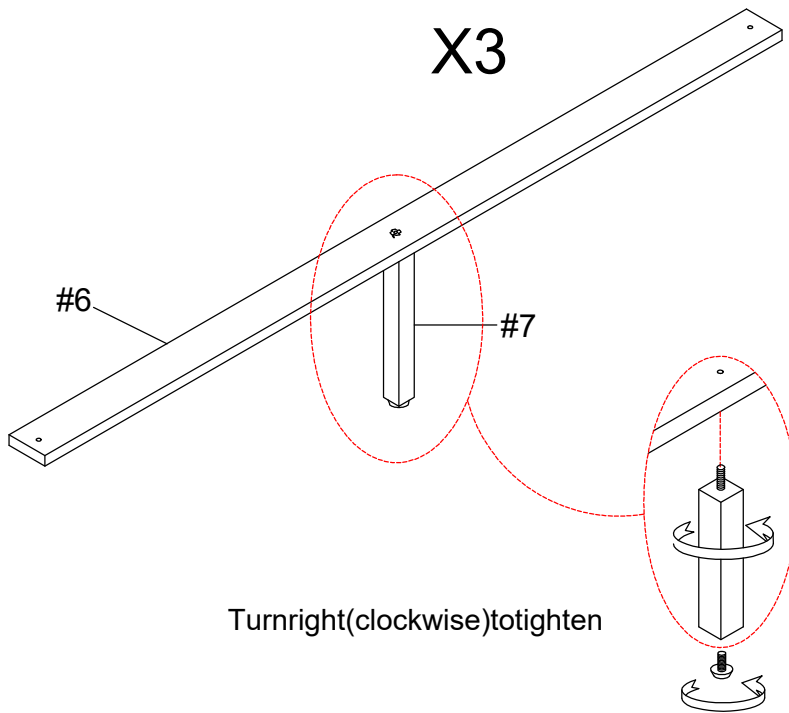

#G x 6 pcs

Turnright(clockwise)totighten

Align the ends of the assembled slat (#6) with the pre-drilled holes on each side of the side rails (#3). Secure two short screws (#G) onto each end of the slat (#6) using a Phillips screwdriver to tighten them down to the side rails (#3). Repeat the process for the remaining three slats (#6).

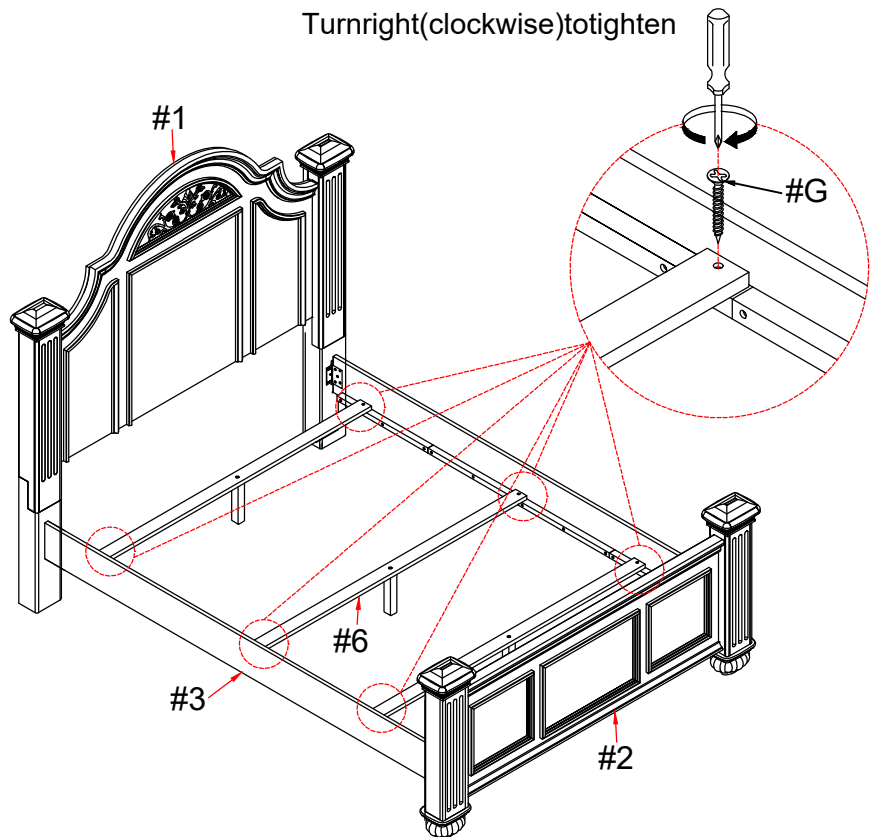

ASSEMBLY IS COMPLETED

Assembly Instructions

CM7129CK

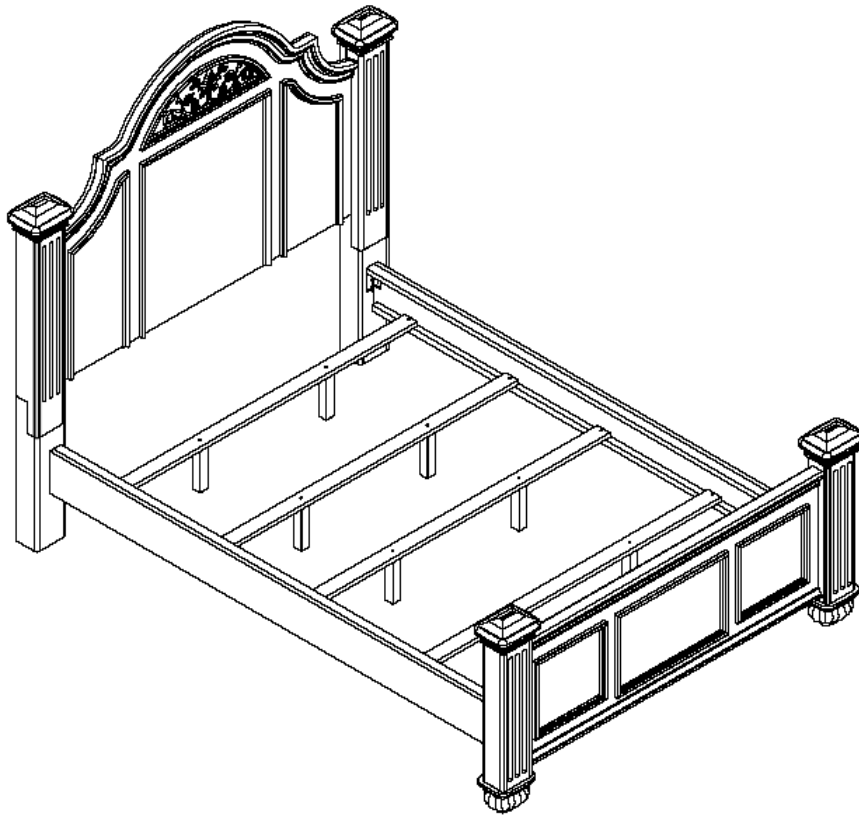

ASSEMBLY RATING

The Assembly Rating is a 5-point system that shows the degree of effort needed in assembling a specific product (with 1 being easy and 5 being difficult). For some products, two persons are recommended.

EASY  DIFFICULT

Tools Required for Assembly:

Allen Wrench



(Included)

Phillips Screwdriver



(Not Included)



2 PERSONS RECOMMENDED

ASSEMBLY & CARE ADVICE

FOR YOUR FURNITURE TO LAST, CORRECT ASSEMBLY AND PROPER MAINTENANCE ARE NECESSARY. PLEASE FOLLOW THE INFORMATION PROVIDED BELOW TO FULLY ENJOY YOUR FURNITURE.

BASIC ASSEMBLY TECHNIQUES

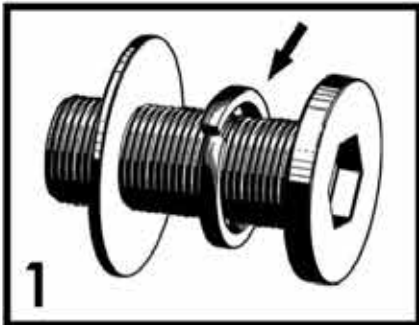

1 When lock or spring washer is used in an assembly, please make sure the lock or spring washer is placed between the larger flat washer and the head of the screw or bolt.

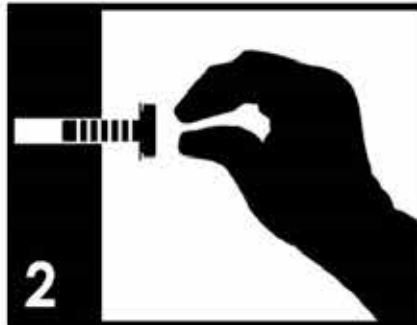

2 Position each part correctly and insert screws or bolts into their respective holes by hand tighten or using the proper hand tool. Only tighten when step is completed or when instructed to do so.



3 Use cardboard or carpet area when assembling furniture to prevent scratches. Make sure the furniture rests on a flat and level surface with each leg evenly touching the floor.

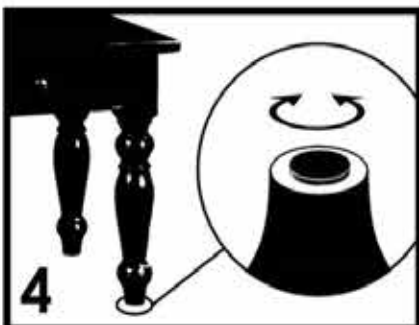

4 Some furniture comes with height adjustment knobs underneath each leg. To lower or to raise each leg, you need to turn clockwise or counterclockwise, respectively.

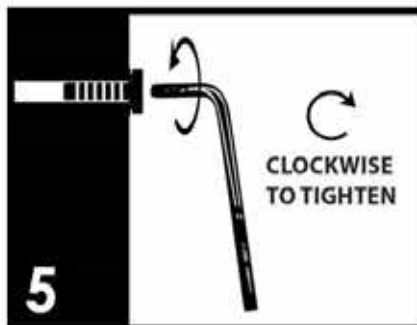

5 Make sure all parts are properly aligned, then use the appropriate hand tool to completely tighten the bolts or screws. Do not use power tools and do not overtighten.

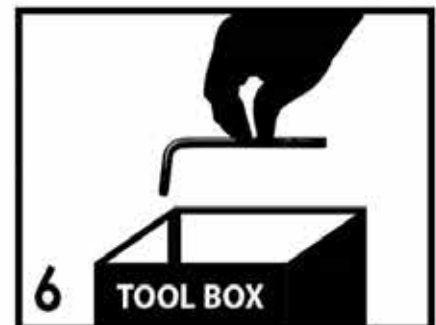

6 Save the instructions and store the Allen wrench or any supplied tool for later maintenance. After two weeks, check and tighten any loose hardware and repeat again every six months thereafter.

IT IS THE USER'S RESPONSIBILITY TO MAINTAIN THE FURNITURE. THE HARDWARE MAY LOOSEN OVER TIME AND MAY CAUSE THE FURNITURE TO BE WOBBLY AND UNABLE TO SUPPORT ITS INTENDED WEIGHT CAPACITY. THIS MAY LEAD TO COLLAPSE AND MAY CAUSE SERIOUS INJURY.



FAILURE TO FOLLOW THE GUIDELINES ABOVE MAY RESULT IN INJURY AND/OR PROPERTY DAMAGE.







Before you begin, please read Page 2 of "Assembly and Care Advice".





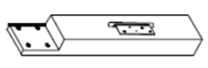
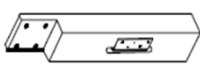
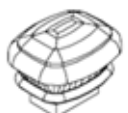

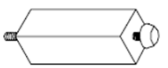
And remember, do not tighten until each step is completed or instructed.

MD

Parts List

-  #1 x 1 pc
Headboard
-  #2 x 1 pc
Footboard
-  #3 x 2 pcs
Side Rail
-  #4R x 1 pc
Right H/B Leg
-  #4L x 1 pc
Left H/B Leg
-  #5 x 4 pcs
Finial
-  #6 x 4 pcs
Slat
-  #7 x 8 pcs
Slat Support Leg

Hardware List

-  #A x 8 pcs
Bolt 1/4"x2-1/2"
-  #B x 8 pcs
Lock Washer
-  #C x 8 pcs
Flat Washer
-  #D x 1 pc
Allen Wrench
-  #E x 4 pcs
Long Screw
-  #F x 2 pcs
Cover
-  #G x 8 pcs
Short Screw



Due to the size and/or weight of this product, it is highly recommended that the assembly should be done near the area of its intended location. Make sure you have enough space to move around during the assembly. ALWAYS have at least two people to help with transporting and assembling of the product to avoid any potential injury and/or damage.



- I. Align the right headboard leg (#4R) with the right side of the headboard (#1).
- II. Prepare 4 bolt assemblies by inserting FIRST the lock washer (#B) onto the bolt (#A) and then the flat washer (#C) onto the SAME bolt (#A), in that order.
- III. Insert the bolt assemblies through the right headboard leg (#4R) and secure those bolts using the Allen wrench (#D) to lock them in with the headboard (#1).
- IV. Repeat process above to assemble the left headboard leg (#4L) onto the left side of the headboard (#1).

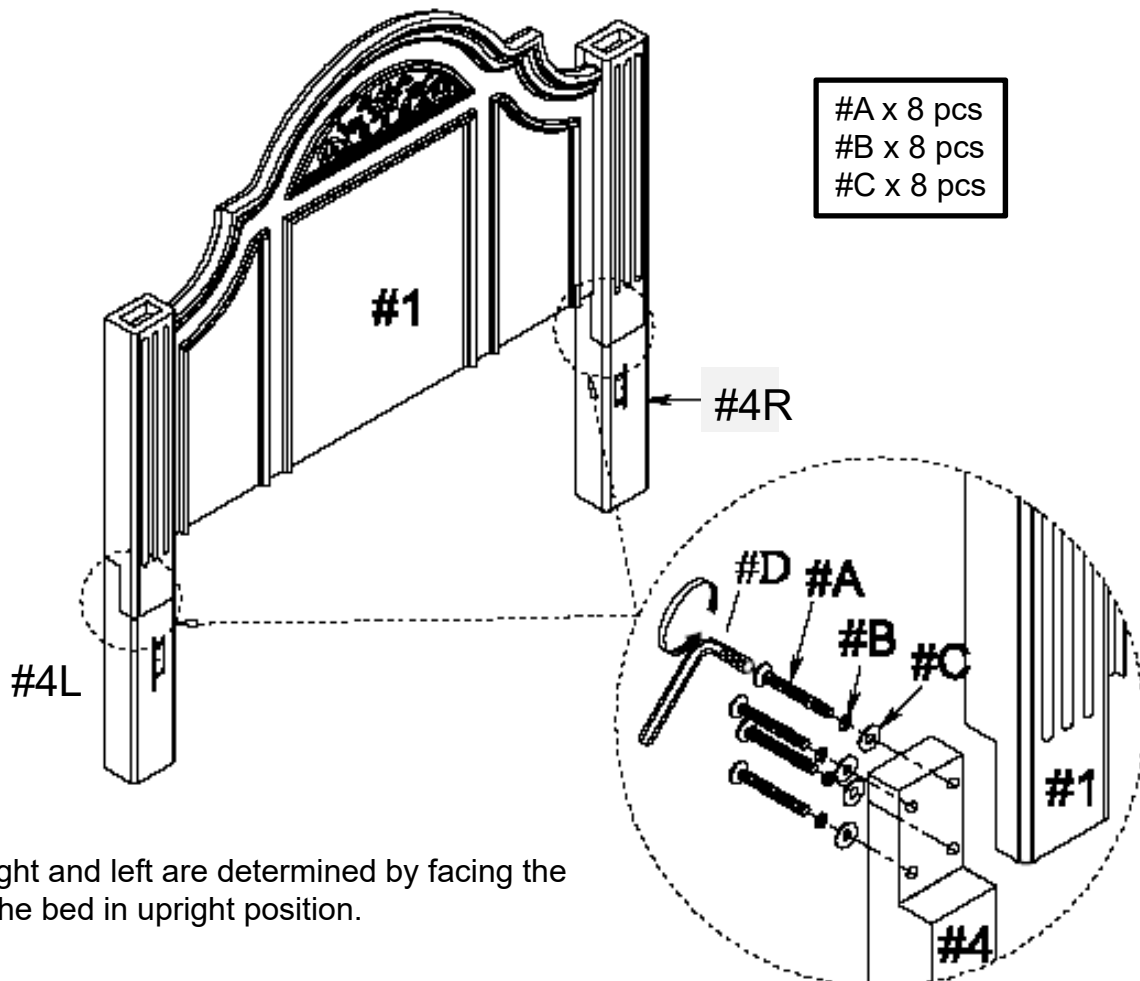

Note: Right and left are determined by facing the front of the bed in upright position.

Turn right (clockwise) to tighten



#E x 4 pcs
#F x 2 pcs

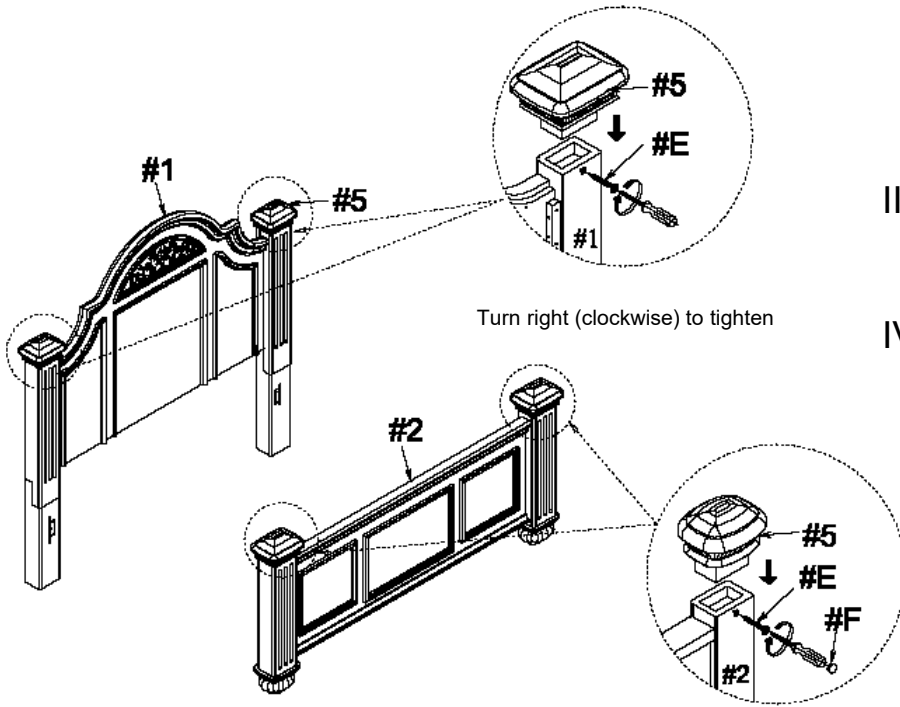

- I. Align the 2 finials (#5) onto the top of the headboard (#1).
- II. Secure two long screws (#E) through the holes on the headboard (#1) using a Phillips screwdriver to tighten them down to the 2 finials (#5).
- III. Align the other 2 finials (#5) onto the top of the footboard (#2).
- IV. Secure two long screws (#E) through the holes on the footboard (#2) using a Phillips screwdriver to tighten them down to the 2 finials (#5). Then place the 2 covers (#F) over the 2 long screws (#E) on the footboard (#2) to cover the holes.



- I. Insert the hooks of the 2 side rails (#3) into the slotted bars of the headboard (#1). Make sure both parts are secured properly.
- II. Insert the hooks on the other ends of the two side rails (#3) into the slotted bars of the footboard (#2). Make sure both parts are secured properly.

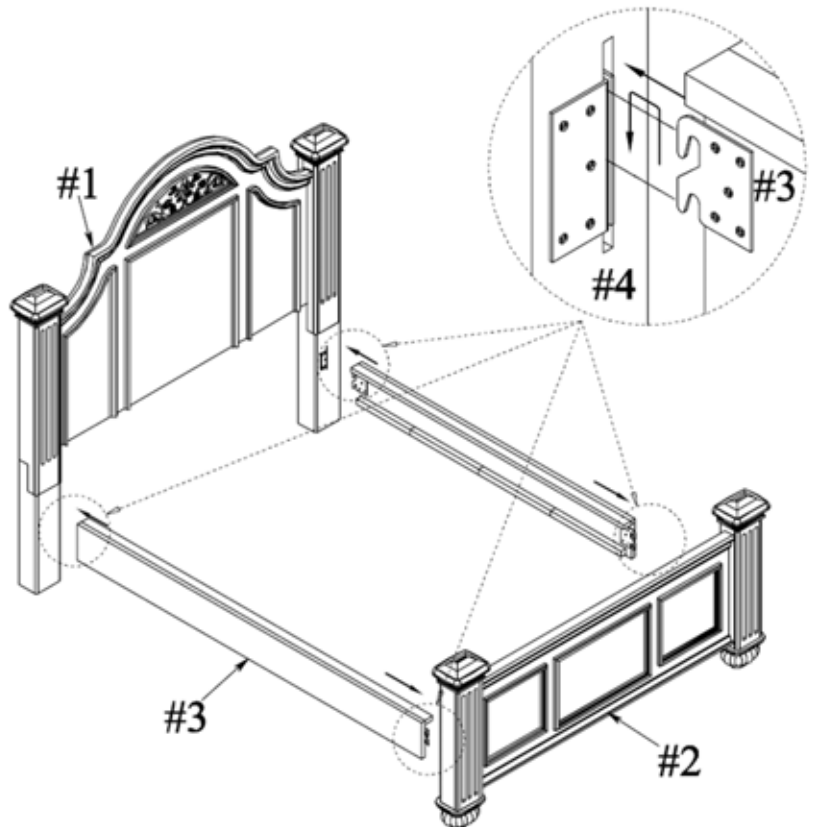



Align the threaded end of the 2 slat support legs (#7) with the pre-drilled holes of the slat (#6) and tighten by hand until secured. Repeat the process for the remaining 6 slat support legs (#7) onto the 3 slats (#6).

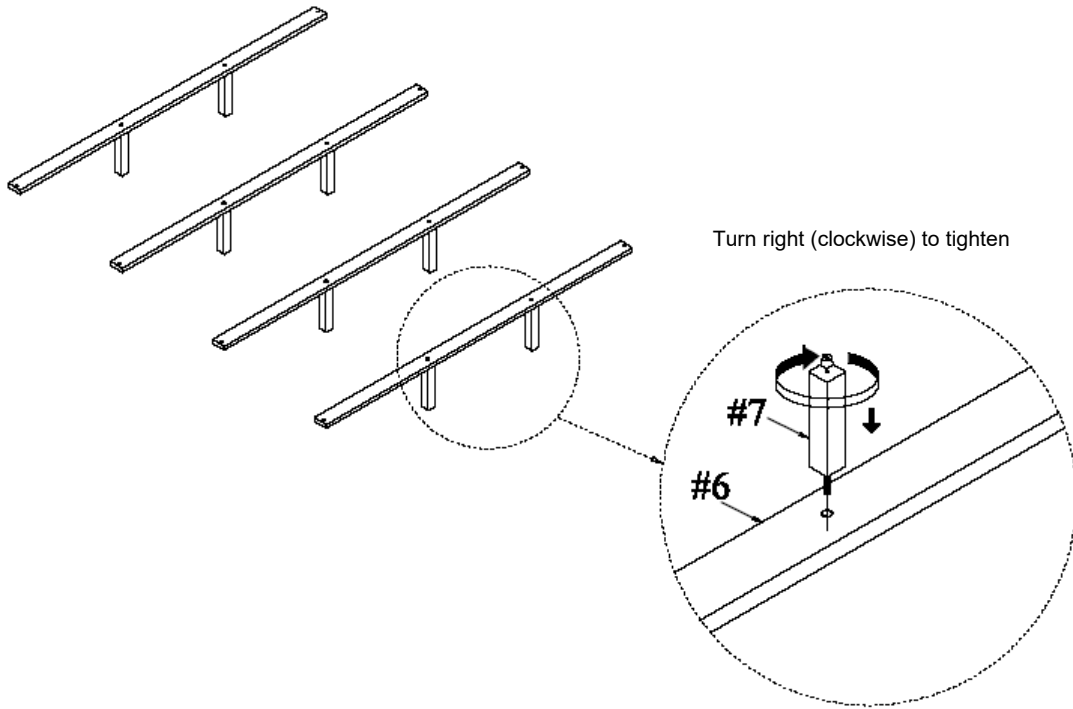

#G x 8 pcs

Turn right (clockwise) to tighten

Align the ends of the assembled slat (#6) with the pre-drilled holes on each side of the side rails (#3). Secure two short screws (#G) onto each end of the slat (#6) using a Phillips screwdriver to tighten them down to the side rails (#3). Repeat the process for the remaining three slats (#6).

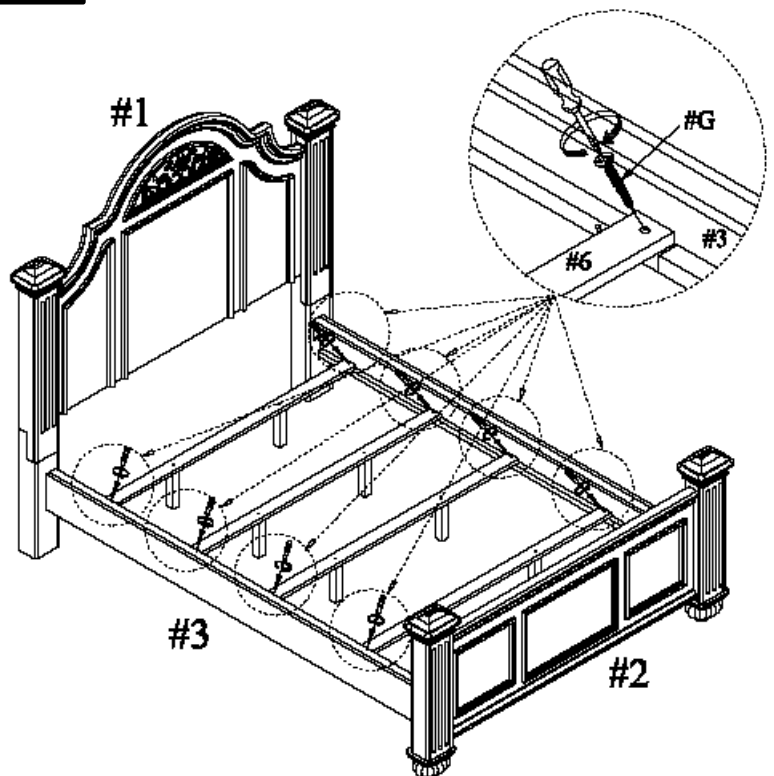

ASSEMBLY IS COMPLETED

Assembly Instructions

CM7129EK

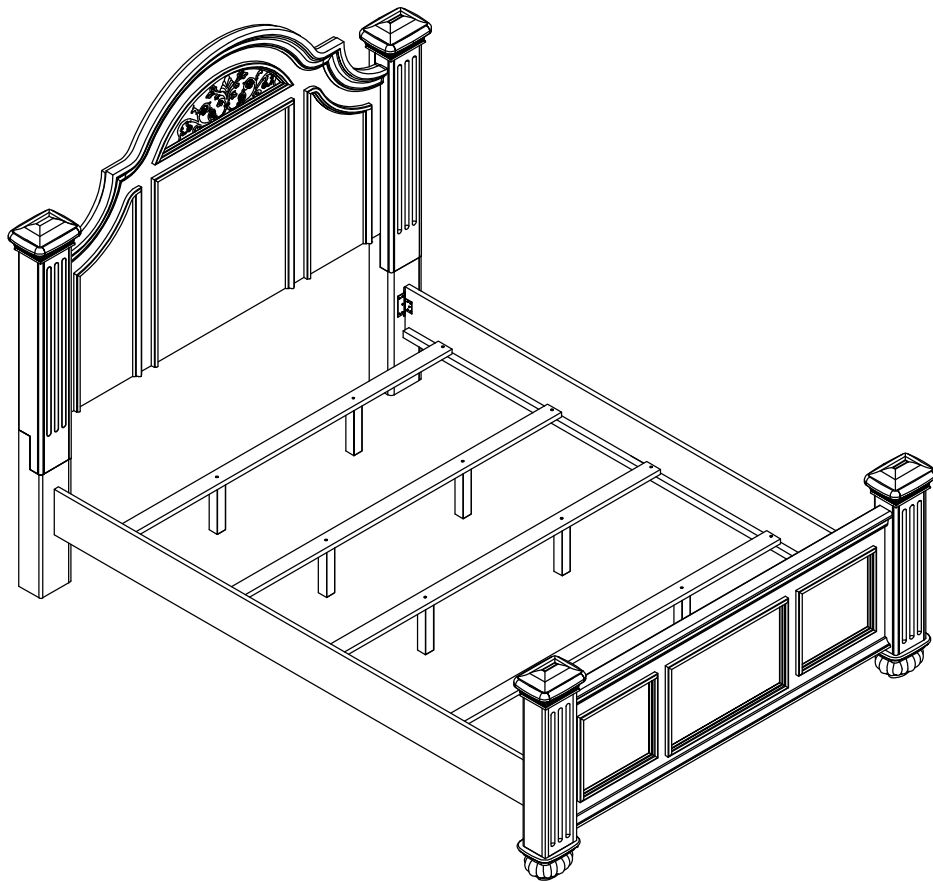

ASSEMBLY RATING

The Assembly Rating is a 5-point system that shows the degree of effort needed in assembling a specific product (with 1 being easy and 5 being difficult). For some products, two persons are recommended.

EASY  DIFFICULT

Tools Required For Assembly:

Allen Wrench

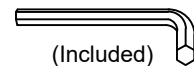

Phillips Screwdriver

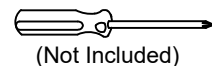

2 PERSONS RECOMMENDED

ASSEMBLY & CARE ADVICE

FOR YOUR FURNITURE TO LAST, CORRECT ASSEMBLY AND PROPER MAINTENANCE ARE NECESSARY. PLEASE FOLLOW THE INFORMATION PROVIDED BELOW TO FULLY ENJOY YOUR FURNITURE.

BASIC ASSEMBLY TECHNIQUES

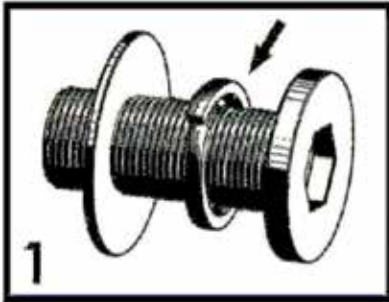

1
When lock or spring washer is used in an assembly, please make sure the lock or spring washer is placed between the larger flat washer and the head of the screw or bolt.

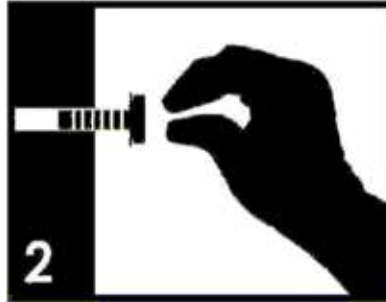

2
Position each part correctly and insert screws or bolts into their respective holes by hand tighten or using the proper hand tool. Only tighten when step is completed or when instructed to do so.

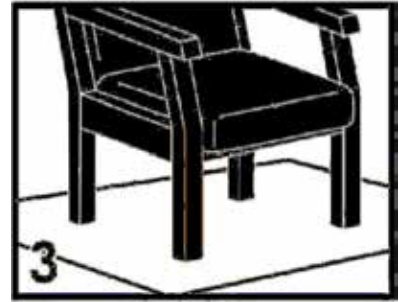

3
Use cardboard or carpet area when assembling furniture to prevent scratches. Make sure the furniture rests on a flat and level surface with each leg evenly touching the floor.

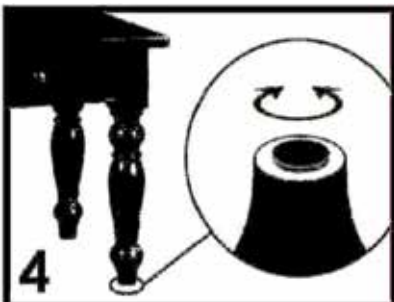

4
Some furniture comes with height adjustment knobs underneath each leg. To lower or to raise each leg, you need to turn clockwise or counterclockwise, respectively.

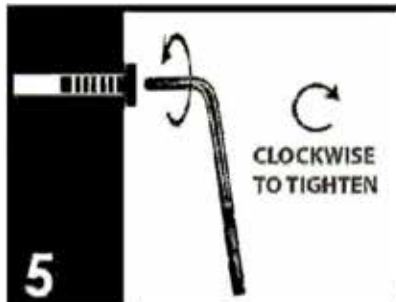

5
Make sure all parts are properly aligned, then use the appropriate hand tool to completely tighten the bolts or screws. Do not use power tools and do not overtighten.



6
Save the instructions and store the Allen wrench or any supplied tool for later maintenance. After two weeks, check and tighten any loose hardware and repeat again every six months thereafter.

IT IS THE USER'S RESPONSIBILITY TO MAINTAIN THE FURNITURE. THE HARDWARE MAY LOOSEN OVER TIME AND MAY CAUSE THE FURNITURE TO BE WOBBLY AND UNABLE TO SUPPORT ITS INTENDED WEIGHT CAPACITY. THIS MAY LEAD TO COLLAPSE AND MAY CAUSE SERIOUS INJURY.



FAILURE TO FOLLOW THE GUIDELINES ABOVE MAY RESULT IN INJURY AND/OR PROPERTY DAMAGE.



Before you begin, please read Page 2 of "Assembly and Care Advice".

And remember, do not tighten until each step is completed or instructed.

MD

Parts List

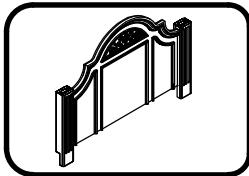

#1 x 1 pc
Headboard

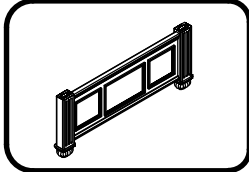

#2 x 1 pc
Footboard

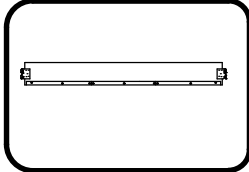

#3 x 2 pcs
Side Rail

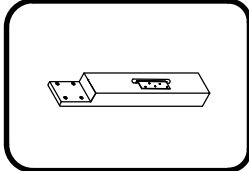

#4 x 2 pcs
Leg (L&R)

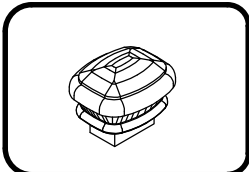

#5 x 4 pcs
Finial

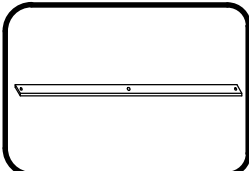

#6 x 4 pcs
Slat

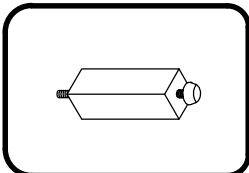

#7 x 8 pcs $\text{\O}1/4''$
Slat Support 35x35x190mm

Hardware List

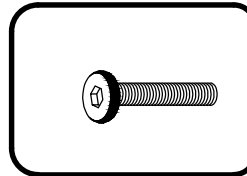

#A x 8 pcs
Bolt $\text{\O}1/4''$ x 2-1/2''



#B x 8 pcs
Lock Washer $\text{\O}1/4''$



#C x 8 pcs
Flat Washer $\text{\O}1/4''$

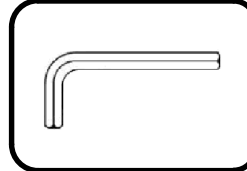

#D x 1 pc
Allen Wrench M4



#E x 4 pcs
Long Screw #4x1-3/8''

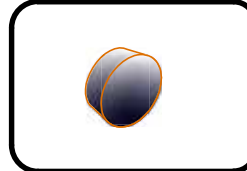

#Fx 2 pcs
Cover



#G x 8 pcs
Short Screw #4x1-3/16''



MD

Before you begin, please read Page 2 of "Assembly and Care Advice".

And remember, do not tighten until each step is completed or instructed.



#A x 8 pcs
#B x 8 pcs
#C x 8 pcs

- I. Align the right headboard leg (#4R) with the right side of the headboard (#1).
- II. Prepare 8 bolt assemblies by inserting FIRST the lock washer (#B) onto the bolt (#A) and then the flat washer (#C) onto the SAME bolt (#A), in that order.
- III. Insert the bolt assemblies through the right headboard leg (#4R) and secure those bolts using the Allen wrench (#D) to lock them in with the headboard (#1).
- IV. Repeat process above to assemble the left headboard leg (#4L) onto the left side of the headboard (#1).

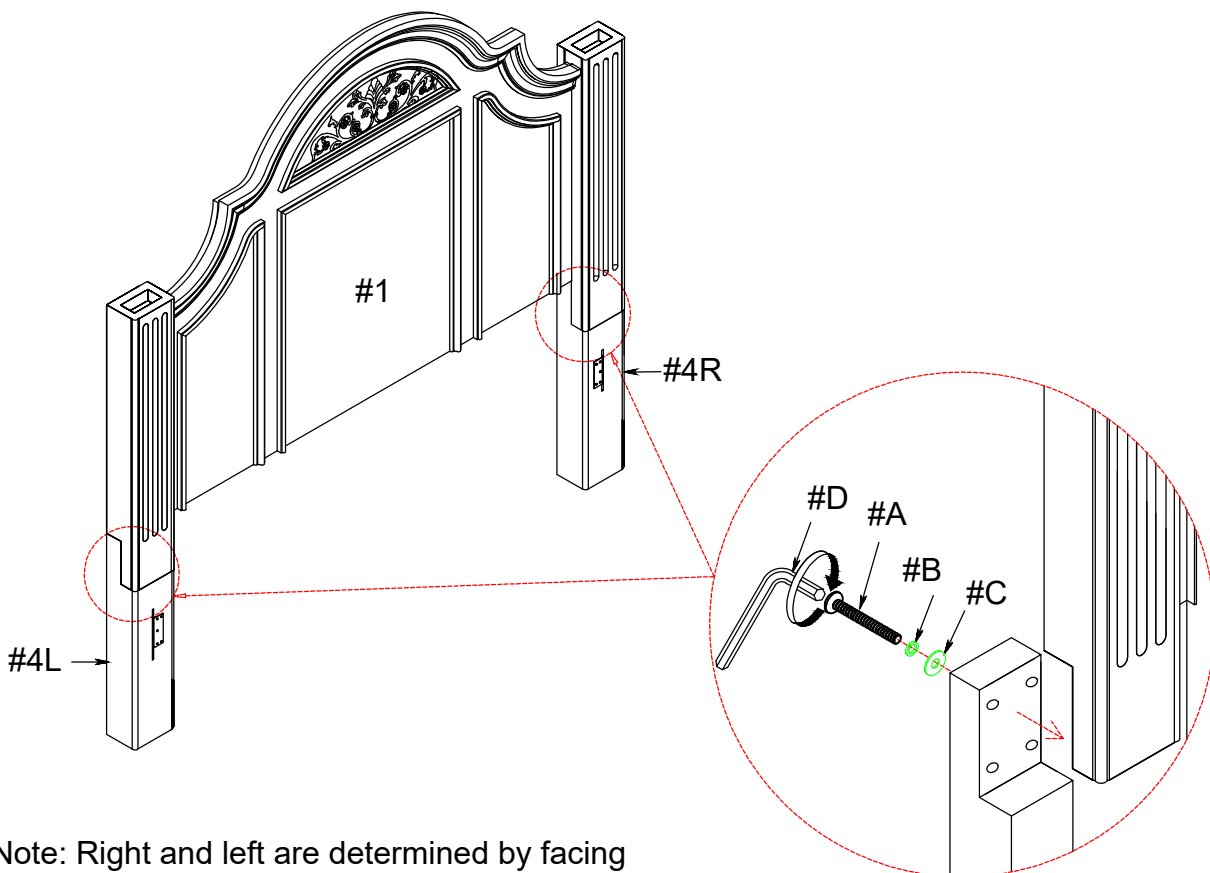

Note: Right and left are determined by facing the front of the bed in upright position.

Turn right (clockwise) to tighten



#E x 4 pcs
#F x 2 pcs

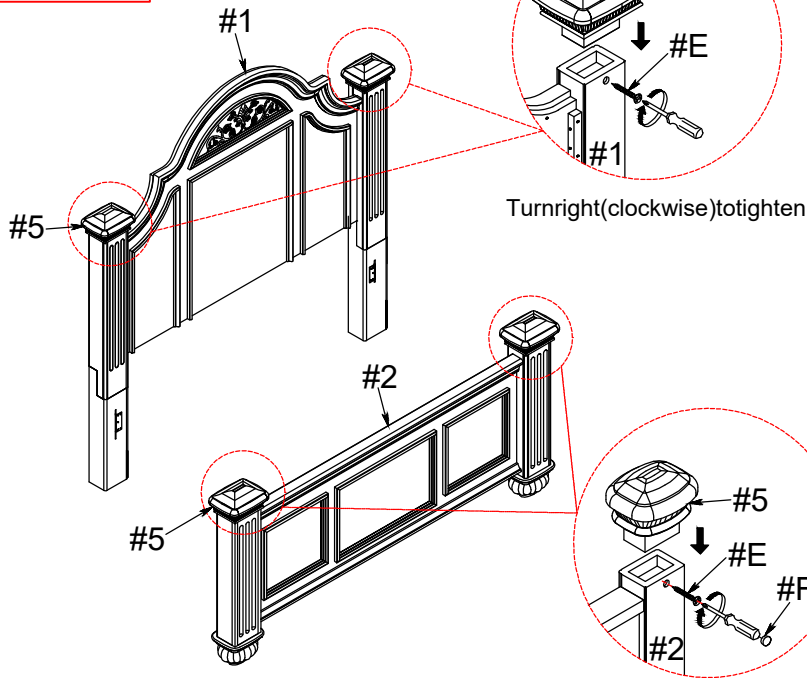

- I. Align the 2 finials (#5) onto the top of the headboard (#1).
- II. Secure two long screws (#E) through the holes on the headboard (#1) using a Phillips screwdriver to tighten them down to the 2 finials (#5).
- III. Align the other 2 finials (#5) onto the top of the footboard (#2).
- IV. Secure two long screws (#E) through the holes on the footboard (#2) using a Phillips screwdriver to tighten them down to the 2 finials (#5). Then place the 2 covers (#F) over the 2 long screws (#E) on the footboard (#2) to cover the holes.

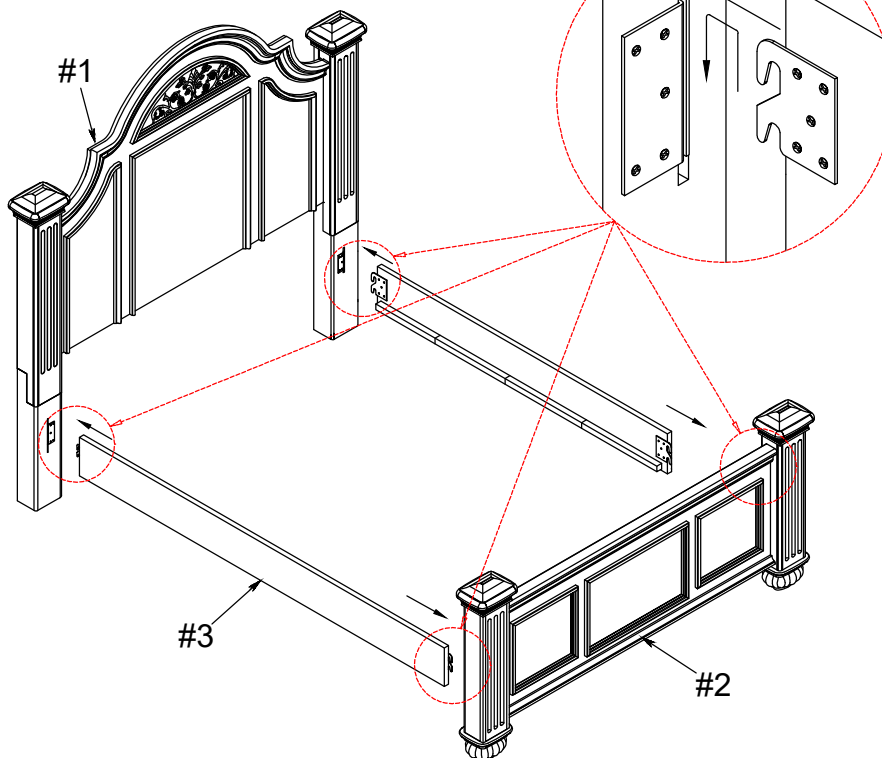

- I. Insert the hooks of the 2 side rails (#3) into the slotted bars of the headboard (#1). Make sure both parts are secured properly.
- II. Insert the hooks of the other ends of the two side rail (#3) into the slotted bars of the footboard (#2). Make sure both parts are secured properly.



Align the threaded end of the 2 slat support leg (#7) with the pre-drilled holes of the slat (#6) and tighten by hand until secured. Repeat the process for the remaining 6 slat support legs (#7) onto the 3 slats (#6).

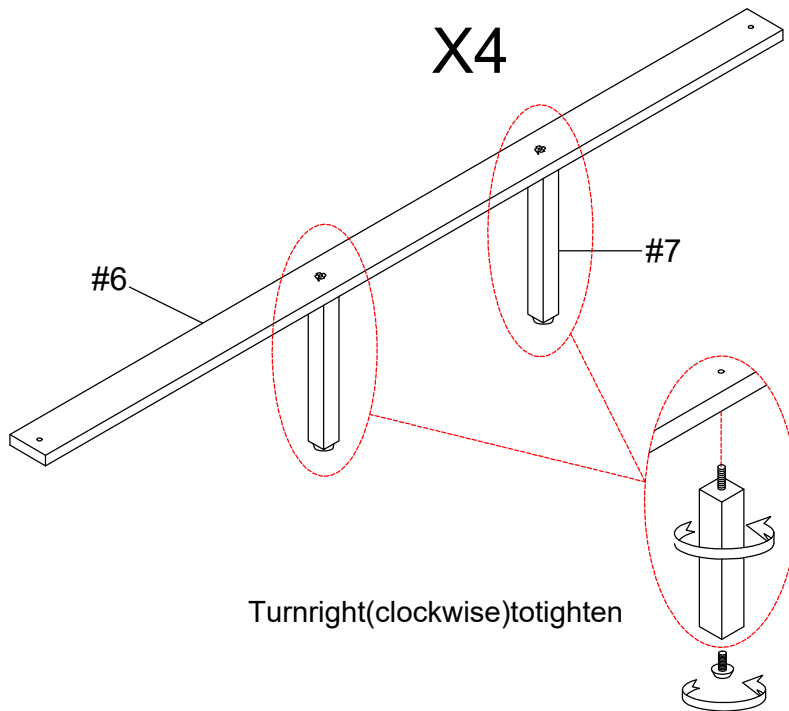

#G x 8 pcs

Align the ends of the assembled slat (#6) with the pre-drilled holes on each side of the side rails (#3). Secure two short screws (#G) onto each end of the slat (#6) using a Phillips screwdriver to tighten them down to the side rails (#3). Repeat the process for the remaining three slats (#6).

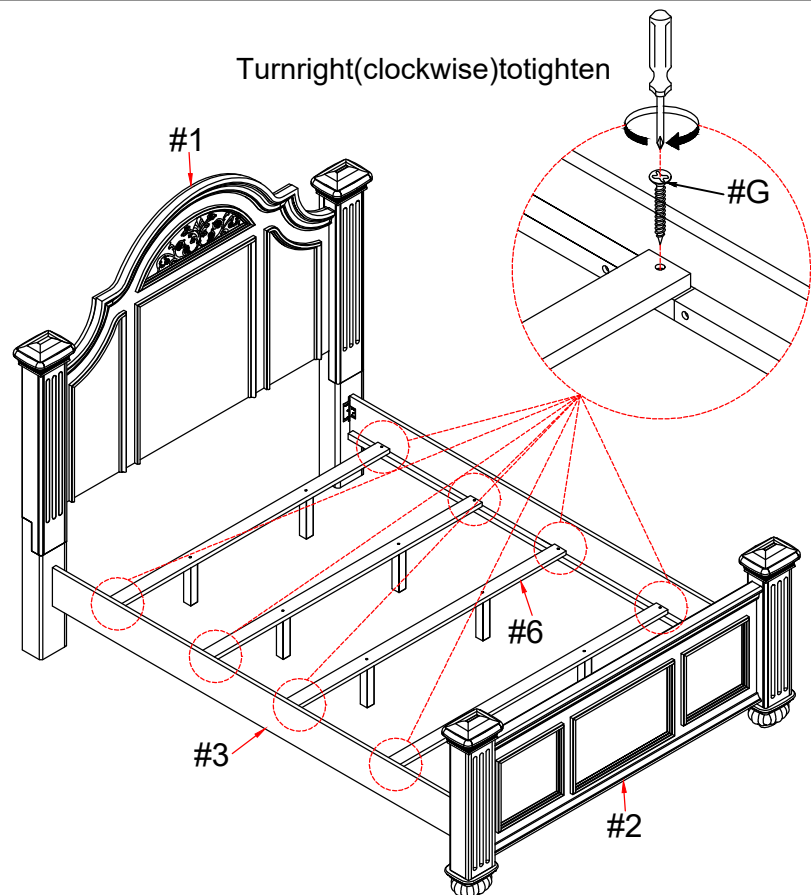

ASSEMBLY IS COMPLETED