



# WALL AND MANTEL CLOCK INSTRUCTION MANUAL

English 1-4

Español Français Deutsch 5-14

## FOLLOW THESE STEPS TO SET UP WALL AND MANTEL CLOCKS

### • SETTING UP YOUR CLOCK

Located in the shipping carton with the clock will be a key to wind the clock. If provided on your model, the shipping carton may also include a pendulum and finial that are separately packed. Please keep all of the original packaging material.

**WARNING: KEEP PLASTIC BAGS AND SMALL PARTS AWAY FROM CHILDREN.**

Access to the clock movement and chimes is made through the back of the clock. Howard Miller uses a combination of rubber bands, foam, styrofoam, metal, and cardboard to secure the movement and chimes during shipping.

Cut rubber bands with scissors and discard.

**DO NOT PULL ON THE RUBBER BANDS TO BREAK.**

Remove foam, styrofoam, and cardboard from around the movement and chimes. When possible, pull in the direction shown to remove. (See figure 1 & 2)

For clocks with a pendulum, cut the rubber band or remove the metal spring clip from the back side of the movement by first pulling one end free. (See figure 2).

Open the front door and remove the white plastic insert holding the minute hand at the 3:00 location (this insert is not used on all models).

Follow the remaining instructions as they apply to your clock.

### • FOR CLOCKS THAT HAVE A PENDULUM -

Follow these instructions for hanging pendulum.

**NOTE:** To perform the following steps, Howard Miller suggests wearing cotton gloves or using a soft cloth when handling parts.

Some pendulums have a colored protective plastic film covering the pendulum disk. Carefully remove this film before hanging the pendulum.

To hang the pendulum, locate the pendulum guide through the front door or back access panel. While holding the pendulum guide with one hand, slip the pendulum through the front door with your other hand. Place the pendulum hook over the pin or through the slot on the end of the pendulum guide, and lower the pendulum until it is hanging securely on the pendulum guide. (See figure 2).

### • FOR CLOCKS THAT HAVE HANGING WEIGHTS -

Follow these instructions for hanging weights.

**Do not remove the styrofoam blocks** until after your clock has been operating for at least eight (8) hours. Check the weights to ensure that they are tightly assembled. Check to make sure that the cable is in the cable pulley. Hang the weights on the pulley. (See figure 3).

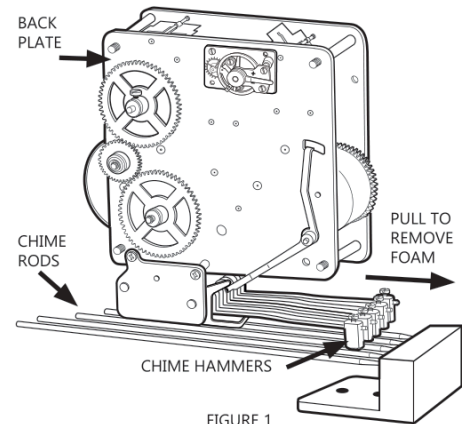

FIGURE 1

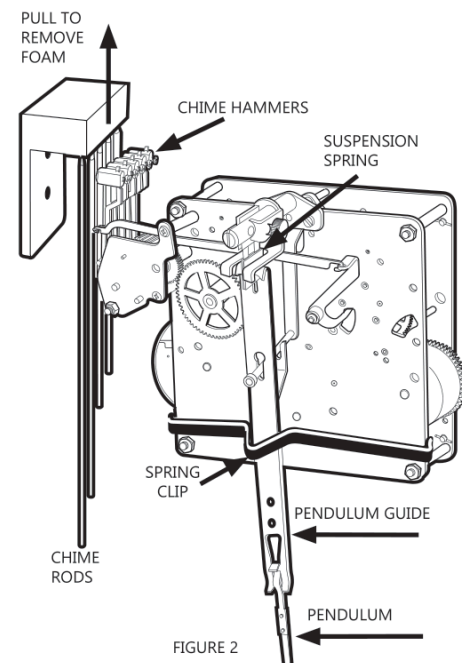

FIGURE 2

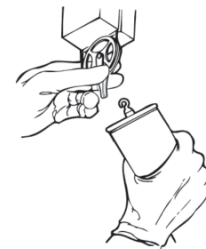

FIGURE 3



VISIT [WWW.HOWARDMILLER.COM](http://WWW.HOWARDMILLER.COM) TO SEE OUR ONLINE VIDEO MANUALS