

Assembly Instruction









ITEM: B2021-110 HARLEQUIN 6/6-6/0 EK/WK HEADBOARD
 B2021-120 HARLEQUIN 6/6-6/0 EK/WK FOOTBOARD & SLATS
 B2021-330 HARLEQUIN 5/0-6/6 Q/EK SIDE RAILS

Thank you for purchasing this quality product. Be sure to check all packing materials carefully for small parts, which may have come loose inside the carton during shipment. Identify and count all items and compare with the PARTS LIST and/ or HARDWARE LIST shown below.



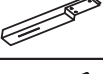



Caution: Please read the instructions thoroughly before assembly.

1. We recommend that you assemble this product with the assistance of another person ; this will make the assembly easier, and will help eliminate damage to the product or injury to persons during assembly.
2. Please do not over tighten screws or bolts until the assembly is completed.
2. Please put all parts on a non-abrasive floor before assembly, and follow the assembly steps to assemble your newly purchased product correctly and effcently.

PARTS LIST

NO:	DESCRIPTION	SKETCH	Q"TY
A	HEADBOARD		1PC
B	FOOTBOARD		1PC
C	SIDE RAIL		2PCS
D	SLATS		5PCS
E	CENTER SUPPORT		10PCS
F	LEG(LEFT)		1PC
G	LEG(RIGHT)		1PC
H	HB BOTTOM RAIL		1PC
I	FB LEG		2PCS

HARDWARE LIST

NO:	DESCRIPTION	SKETCH	Q"TY
1	JCBC BOLT Ø5/16**38MM		8PCS
2	SPRING WASHER Ø5/16"Ø12MM		10PCS
3	FLAT WASHER Ø5/16"Ø16MM		10PCS
4	JCBC BOLT Ø1/4**100MM		2PCS
5	ALLEN KEY		1PC
6	SCREWS Ø8*Ø4*L25mm		10PCS

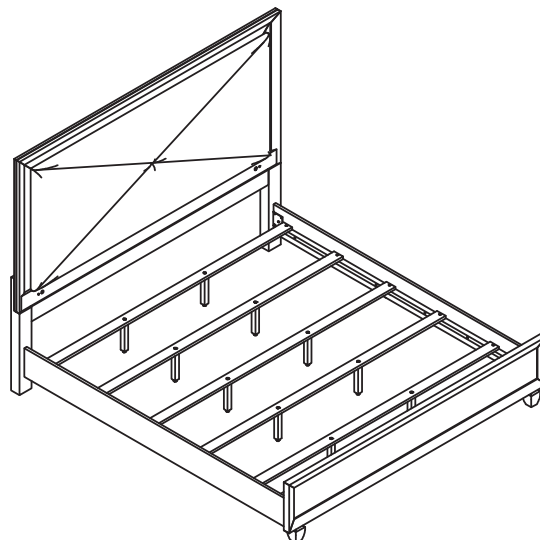



Assembly Instruction

ITEM: B2021-110 HARLEQUIN 6/6-6/0 EK/WK HEADBOARD
B2021-120 HARLEQUIN 6/6-6/0 EK/WK FOOTBOARD & SLATS
B2021-330 HARLEQUIN 5/0-6/6 Q/EK SIDE RAILS

STEP:1

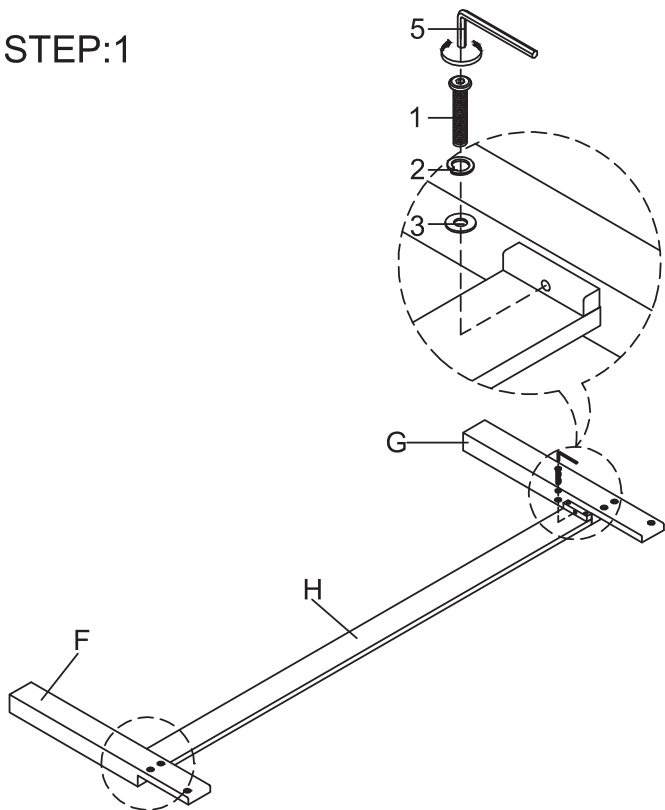

STEP:2

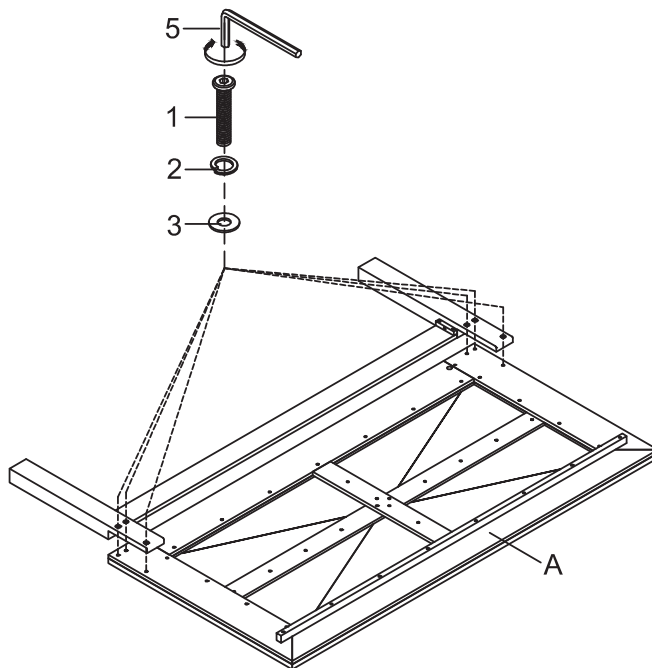

STEP:3

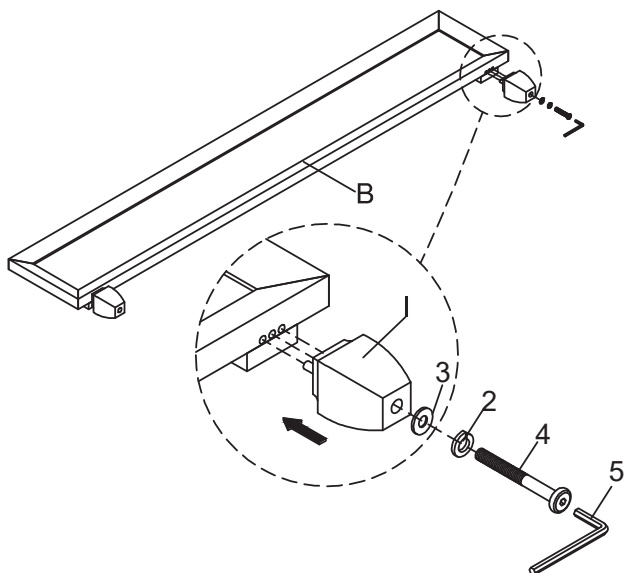

STEP:4

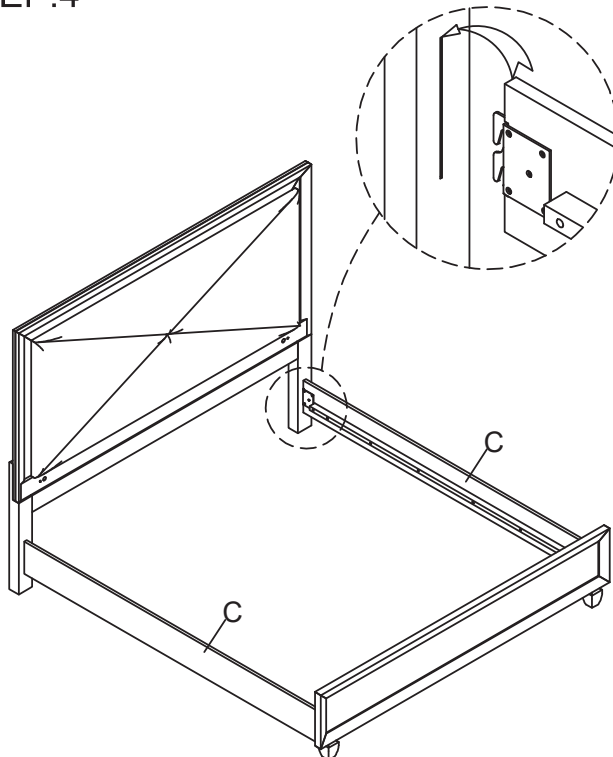



Assembly Instruction

ITEM: B2021-110 HARLEQUIN 6/6-6/0 EK/WK HEADBOARD
B2021-120 HARLEQUIN 6/6-6/0 EK/WK FOOTBOARD & SLATS
B2021-330 HARLEQUIN 5/0-6/6 Q/EK SIDE RAILS

STEP:5

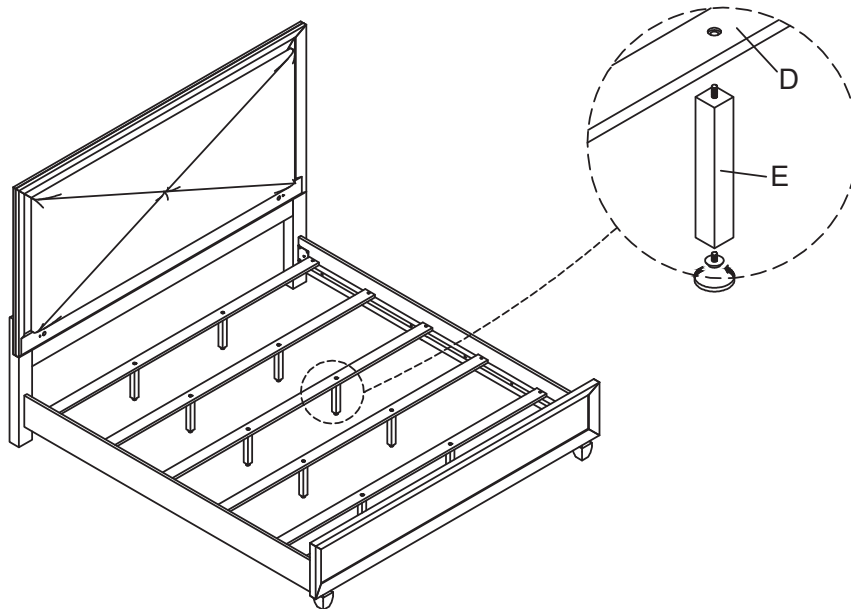

STEP:6

