



KM-231BAJ

SELF-CONTAINED CUBER
WITH BUILT-IN STORAGE BIN



KM-231BAJ
04/26/24
Item # 13555

Item #: _____
Project: _____
Qty: _____
AIA#: _____

W x D x H
24" x 28" x 39" *
*including 6" legs

ADA Compliant

KMEDGE™

KM-231BAJ
Air-Cooled
Shown



Features

- ▶ Individual crescent cube
- ▶ Stainless steel evaporator
- ▶ CycleSaver™ design

- Up to 213 lbs. of ice production per 24 hours
- Built-in storage capacity of 2.7ft³/80 lbs.*
- Durable stainless steel exterior
- Front-in, front-out airflow
- Removable air filter (Air-cooled model only)
- Ice bin opening is ADA compliant
- 6.5ft.(2000 mm) power cord with NEMA 5-15P plug
- EverCheck™ alert system
- R-404A Refrigerant

Warranty:

3 Year Parts & Labor on entire machine. 5 Year Parts & Labor on Evaporator. 5 Year Parts on Compressor; air-cooled condenser coil. Valid in United States, Canada, Puerto Rico and U.S. Territories. Contact factory for warranty in other countries.

Shipping: (LxWxH) 34" x 33" X 39" Volume: 25.32ft³



Condenser	Model	ICE PRODUCTION		WATER USAGE		ELECTRICAL			Heat Rejection BTU/hr.	Refrigerant Charge Amount	Net / Ship Weight (lbs.)	
		Air / Water Temp Lbs. per 24 hours 70°/ 50°F 90°/ 70°F	Potable Gal. per 100 lbs. 90°/ 70°F	Condenser Gal. per 100 lbs. 90°/ 70°F	kWh Used per 100 lbs. 90°/ 70°F	Min. Circuit/Max. Fuse Size	Amperage	Voltage				
Air-Cooled	KM-231BAJ	213	147	23.5	N/A	8.4	15A	6.5A	115V/60/1	3,750	11.3 oz.	137 / 165

KMEdge™ Cube Dimensions*

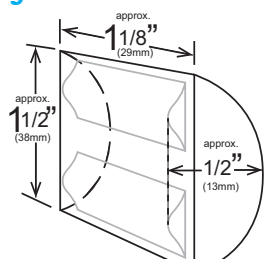

* approximate size in inches, image not to scale

Operating Limits

- Ambient Temp Range 45 - 100°F
- Water Temp Range 45 - 90°F
- Water Pressure 10 - 113 PSIG
- Voltage Range 104 - 127V
- If GFCI is required, a GFCI breaker MUST be used in lieu of GFCI receptacle

Service

- Allow enough space at rear for water supply and drain connections. Allow at least 2" (5 cm) on right side for proper air circulation and at least 0.6" (15 mm) clearance at top for service/maintenance.

Plumbing

- Icemaker Water Supply Line: Minimum 1/4" Nominal ID Copper Water Tubing or Equivalent
- Icemaker Drain Line: Minimum 3/4" Nominal ID Hard Pipe or Equivalent

Water Filter

Please refer to water filter spec sheet for recommended configurations.

Hoshizaki reserves the right to change specifications without notice.



KM-231BAJ

SELF-CONTAINED CUBER
WITH BUILT-IN STORAGE BIN



KM-231BAJ
04/26/24
Item # 13555

mm
[inch]

FRONT VIEW

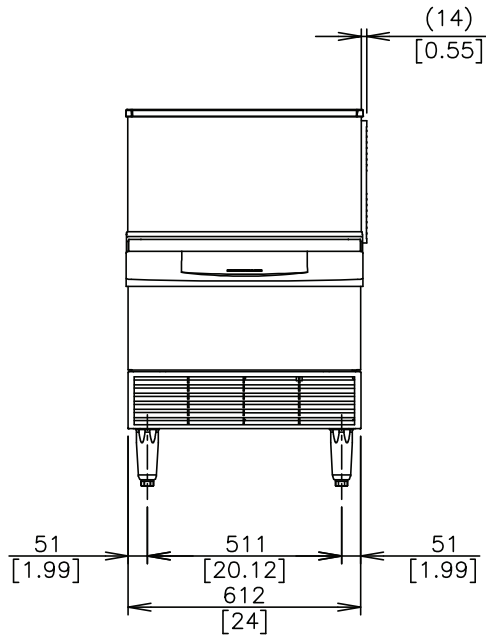

SIDE VIEW

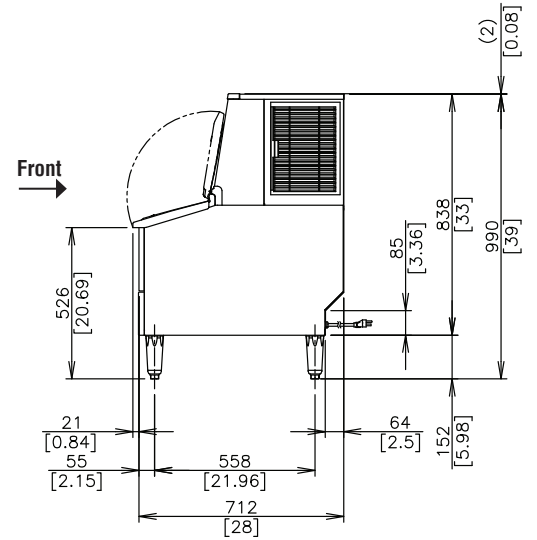

REAR VIEW

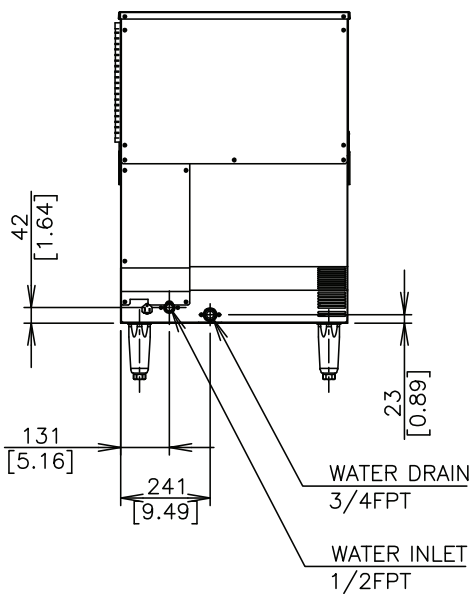

TOP VIEW

