

Assembly Instructions



D2114-21 MARIANA WOOD BACK CHAIR (2 PER CARTON)

Thank you for purchasing this quality product. Be sure to check all packing materials carefully for small parts, which may have come loose inside the carton during shipment. Identify and count all items and compare with the PARTS LIST and/or HARDWARE LIST shown below.

Caution: Please read the instructions thoroughly before assembly.





1. We recommend that you assemble this product with the assistance of another person; this will make the assembly easier, and will help eliminate damage to the product or injury to persons during assembly.
2. Please do not over tighten screws or bolts until the assembly is completed.
3. Please put all parts on a non-abrasive floor before assembly, and follow the assembly steps to assemble your newly purchased product correctly and efficiently.

PARTS LIST

NO:	COMPONENT	SKETCH	Q'TY
A	Chair Back		2 PCS
B	Cushion seat		2 PCS
C	Front Leg		4 PCS

WEIGHT CAPACITY (PER CHAIR)	250 LBS
-----------------------------	---------

HARDWARE LIST

NO:	COMPONENT	SKETCH	Q'TY
1	Allen Key		1 PC
2	Long Bolt 5/16"*3-3/4"L		8 PCS
3	Short Bolt 5/16"*2-1/4"L		10 PCS
4	Lock Washer 5/16"		18 PCS
5	Flat Washer 5/16"		18 PCS

STEP 1 Place the chair back (A) on a soft and clean surface.

Assemble the Cushion Seat (B) with the Chair Back (A) by using Allen Key (1) with hardware 3, 4, and 5.

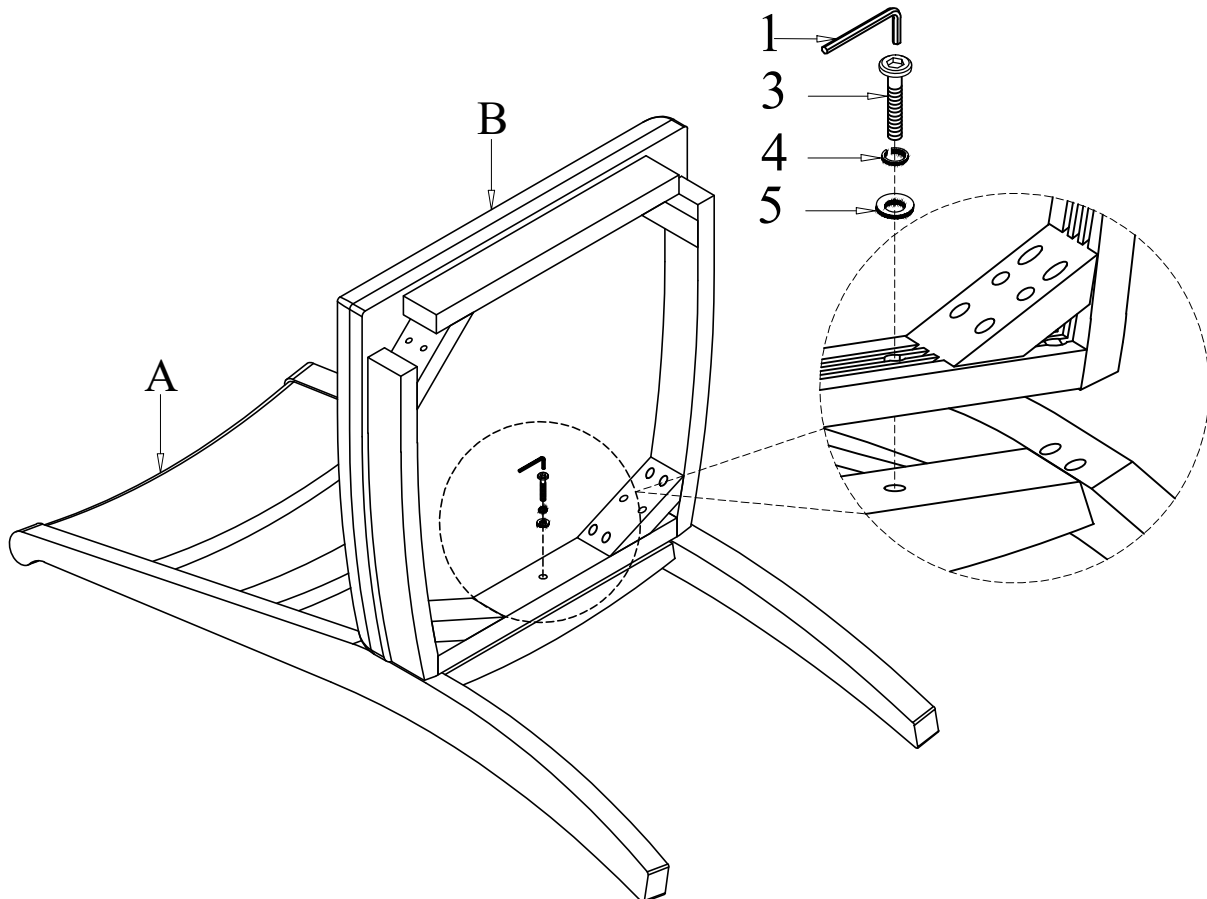

Assembly Instructions

D2114-21 MARIANA WOOD BACK CHAIR (2 PER CARTON)

STEP 2 Assemble the Cushion Seat (B) with the back legs of the Chair Back (A) by using Allen Key (1) with hardware 2, 4, and 5.

****Attention: DO NOT TIGHTEN THE BOLTS**

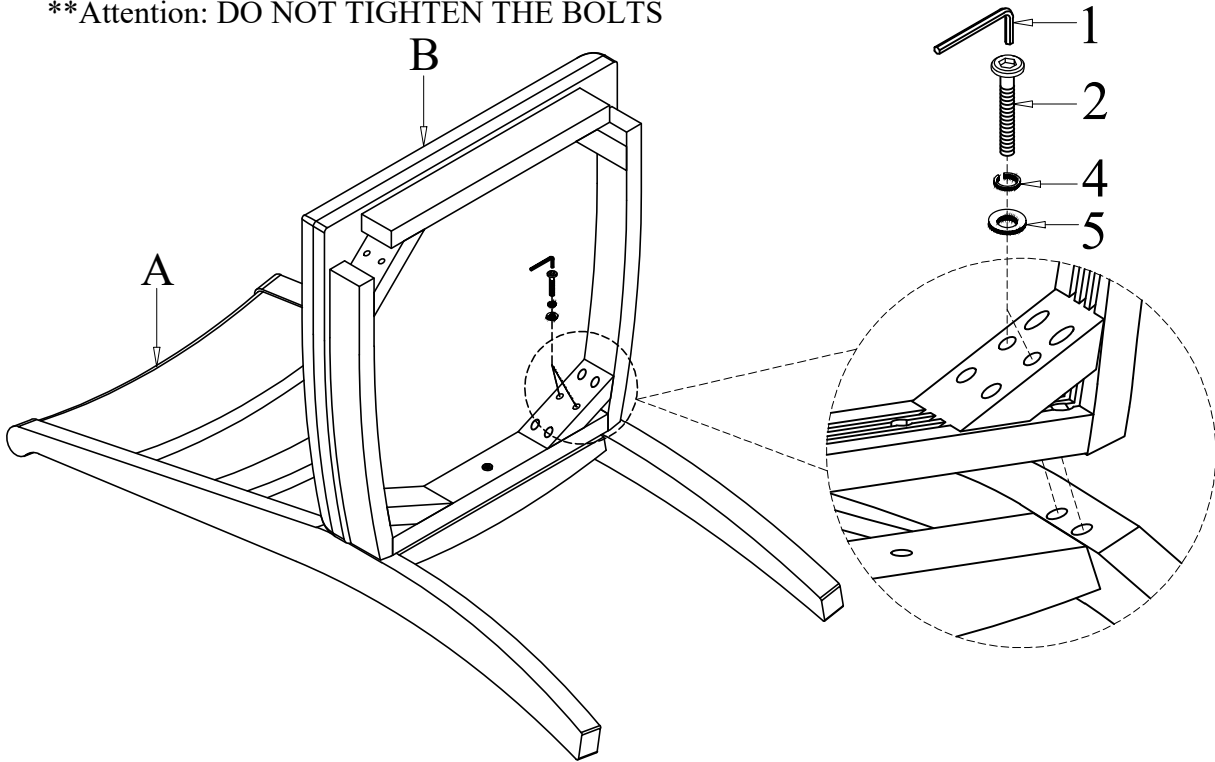

STEP 3 Assemble the Front Legs (C) with the Cushion Seat (B) by using Allen Key (1) with hardware 3, 4, and 5.

****Attention: DO NOT TIGHTEN THE BOLTS.**

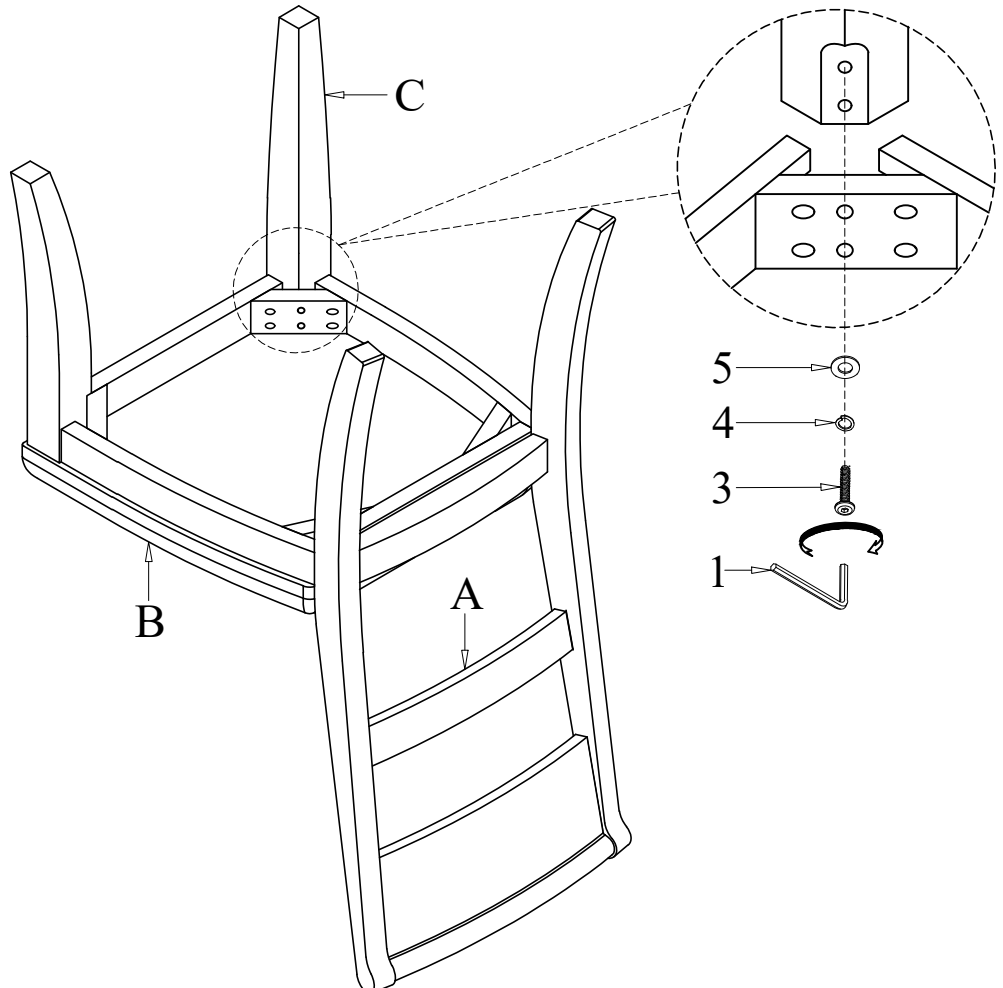

STEP 4 To level the chair, stand the chair up on a flat surface and tighten all the bolts by using Allen Key (1).

