

Furniture of America[®]

Assembly Instructions

CM7739F/Q

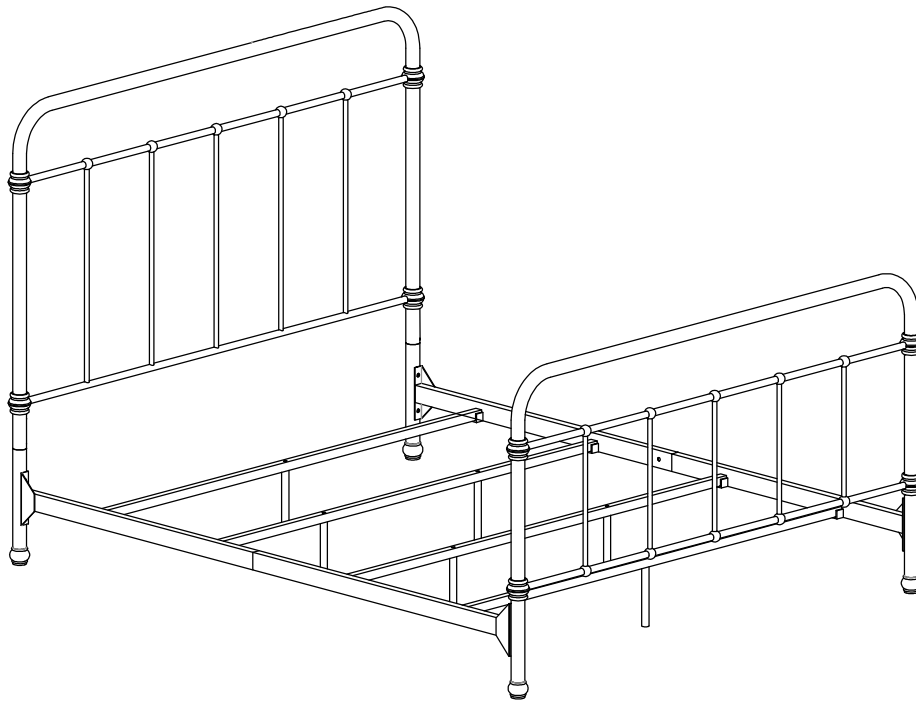

ASSEMBLY RATING

The Assembly Rating is a 5-point system that shows the degree of effort needed in assembling a specific product (with 1 being easy and 5 being difficult). For some products, two persons are recommended.

Tools Required For Assembly:

Allen Wrench

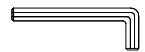

(Included)

EASY



DIFFICULT

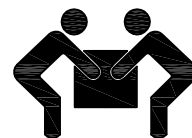

2 PERSONS RECOMMENDED

ASSEMBLY & CARE ADVICE

FOR YOUR FURNITURE TO LAST, CORRECT ASSEMBLY AND PROPER MAINTENANCE ARE NECESSARY. PLEASE FOLLOW THE INFORMATION PROVIDED BELOW TO FULLY ENJOY YOUR FURNITURE.

BASIC ASSEMBLY TECHNIQUES



When lock or spring washer is used in an assembly, please make sure the lock or spring washer is placed between the larger flat washer and the head of the screw or bolt.



Position each part correctly and insert screws or bolts into their respective holes by hand tighten or using the proper hand tool. Only tighten when step is completed or when instructed to do so.

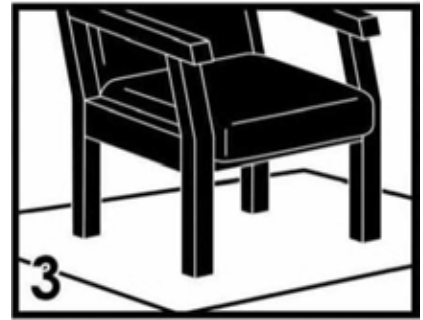

Use cardboard or carpet area when assembling furniture to prevent scratches. Make sure the furniture rests on a flat and level surface with each leg evenly touching the floor.

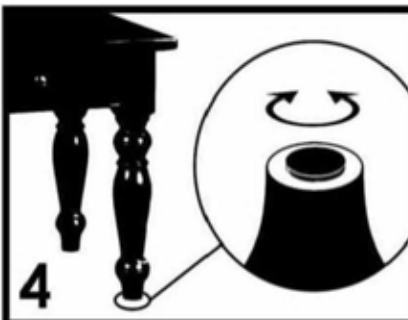

Some furniture comes with height adjustment knobs underneath each leg. To lower or to raise each leg, you need to turn clockwise or counterclockwise, respectively.

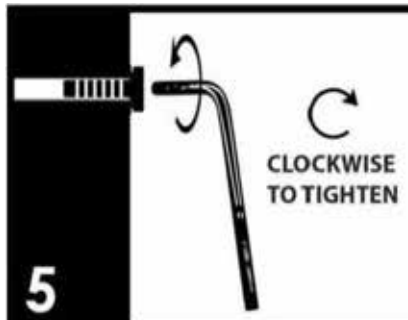

Make sure all parts are properly aligned, then use the appropriate hand tool to completely tighten the bolts or screws. Do not use power tools and do not overtighten.



Save the instructions and store the Allen wrench or any supplied tool for later maintenance. After two weeks, check and tighten any loose hardware and repeat again every six months thereafter.

IT IS THE USER'S RESPONSIBILITY TO MAINTAIN THE FURNITURE. THE HARDWARE MAY LOOSEN OVER TIME AND MAY CAUSE THE FURNITURE TO BE WOBBLY AND UNABLE TO SUPPORT ITS INTENDED WEIGHT CAPACITY. THIS MAY LEAD TO COLLAPSE AND MAY CAUSE SERIOUS INJURY.

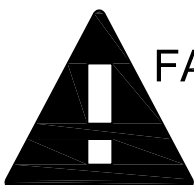

FAILURE TO FOLLOW THE GUIDELINES ABOVE MAY RESULT IN INJURY AND/OR PROPERTY DAMAGE.



Before you begin, please read Page 2 of "Assembly and Care Advice".

And remember, do not tighten until each step is completed or instructed.

Parts List

Hardware List

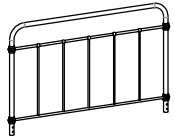

#1 x 1pc
Headboard

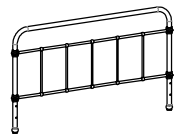

#2 x 1pc
Footboard

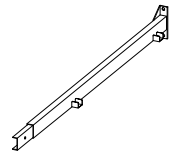

#3 x 2pcs
Side Rail

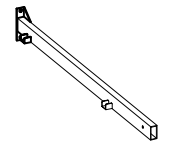

#4 x 2pcs
Side Rail

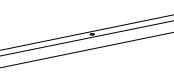

#5 x 2pcs
Slat

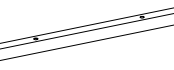

#6 x 2pcs
Slat



#7 x 6pcs
Support Leg

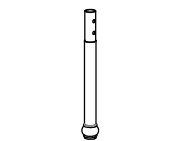

#8 x 2pcs
Extension Leg



#A x 18pcs
Bolt 1/4" X 5/8"

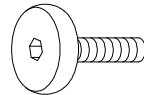

#B x 8pcs
Bolt 1/4" X 3/4"

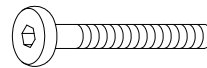

#C x 6pcs
Bolt 1/4" X 1-3/4"

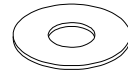

#D x 28pcs
Flat washer

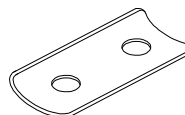

#E x 2pcs
Connecting plate





#F x 1pc
Allen Wrench

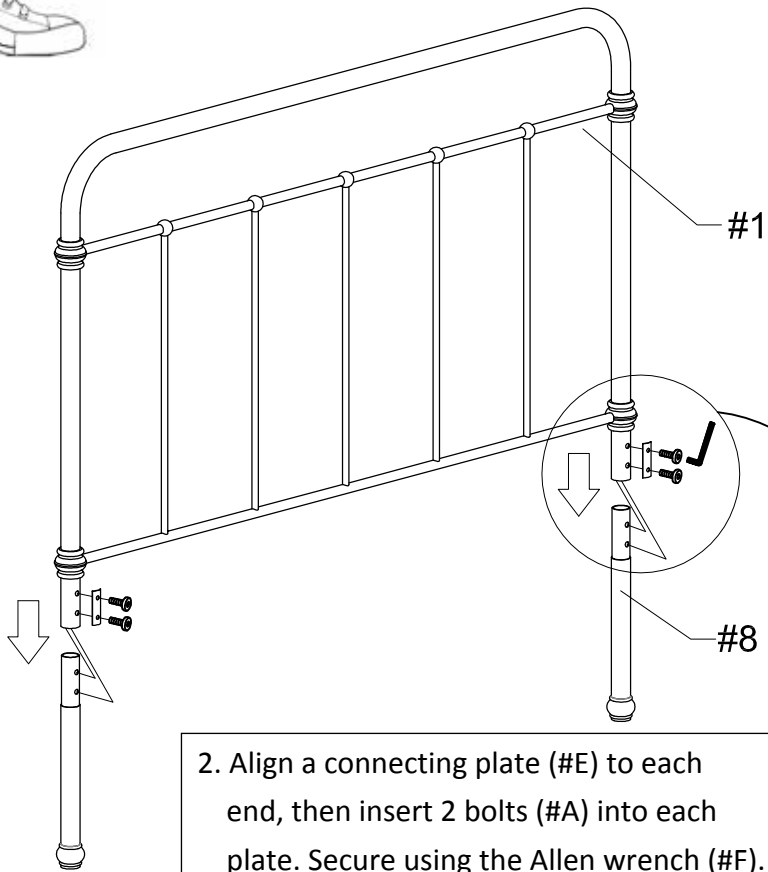

1. Insert the extension legs (#8) into the holes at the end of the headboard (#1).



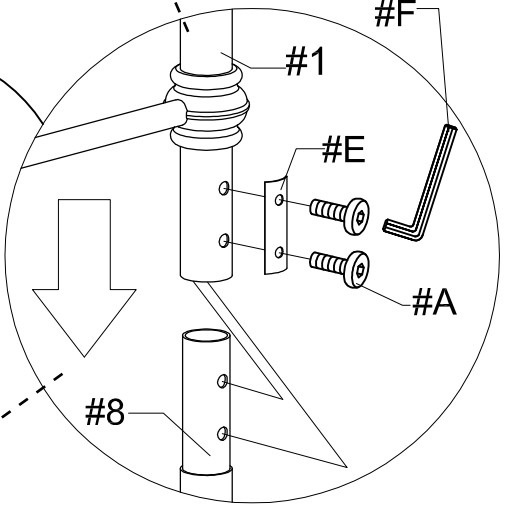

- #F 
- #A  X 4 pcs
- #E  X 2 pcs

2. Align a connecting plate (#E) to each end, then insert 2 bolts (#A) into each plate. Secure using the Allen wrench (#F).

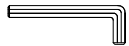

1. Insert the side rails (#3) into the side rails (#4).
 2. Prepare 6 bolt assemblies by inserting a flat washer (#D) onto the bolt (#A), then insert those bolt assemblies into the holes along the center of the rails. Secure using the Allen wrench.

- #F 
- #A  X 6 pcs
- #D  X 6 pcs

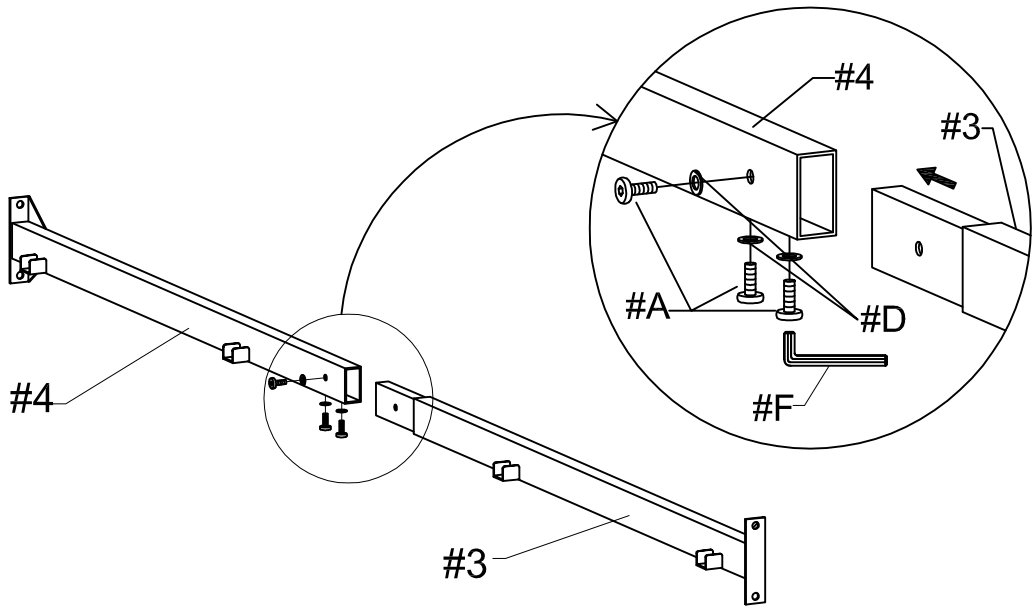



1. Prepare 6 bolt assemblies by inserting a flat washer (#D) onto the bolts (#C).

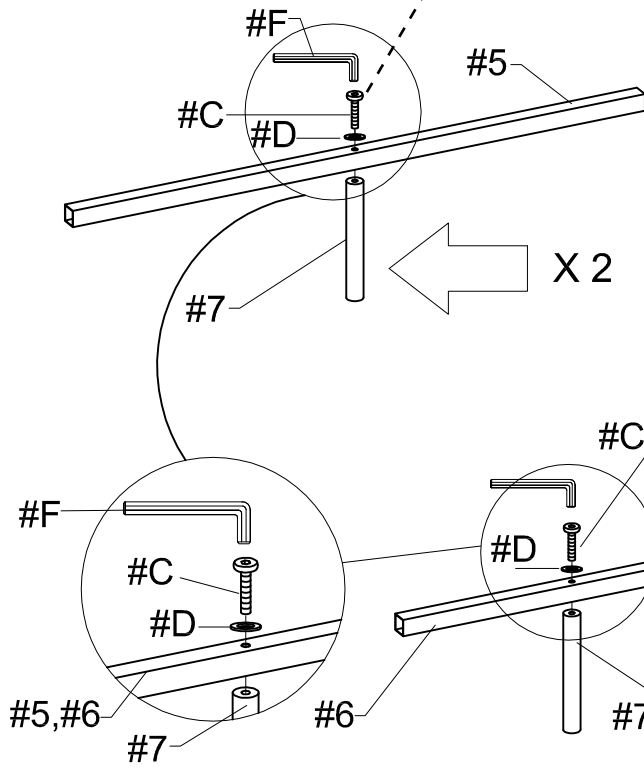
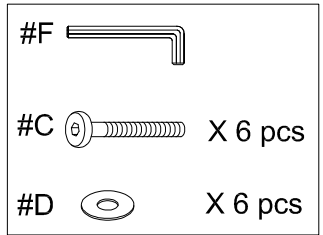

2. Align the support legs (#7) to the holes along the slats (#5,6), then insert a bolt assembly from above into each hole. Secure using the Allen wrench (#F).

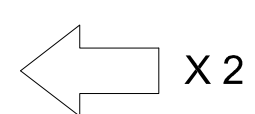

1. Prepare 8 bolt assemblies by inserting a flat washer (#D) onto the bolts (#B).

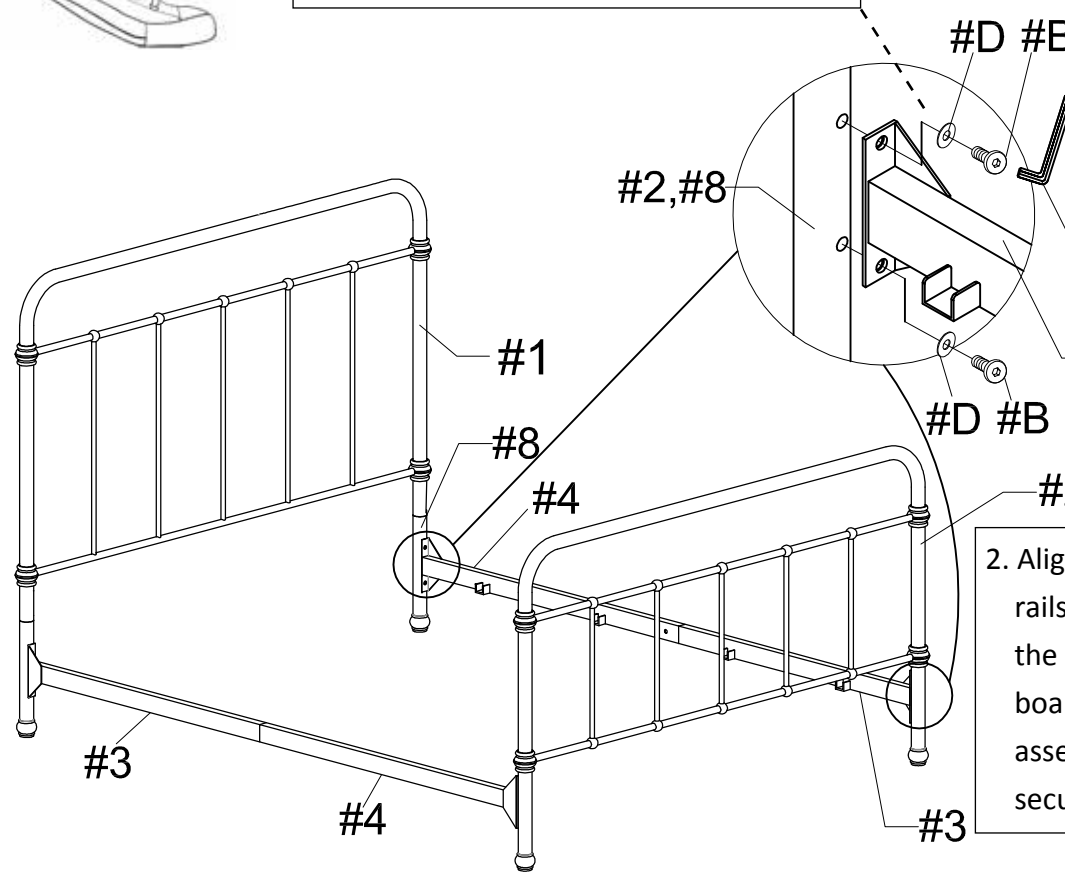
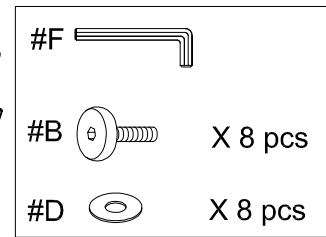

2. Align the ends of the side rails (#3,4) to the holes along the headboard (#1) and footboard (#2). Insert 2 bolt assemblies into each end and secure using the Allen wrench.



1. Prepare 8 bolt assemblies by inserting a flat washer (#D) onto the bolts (#A).

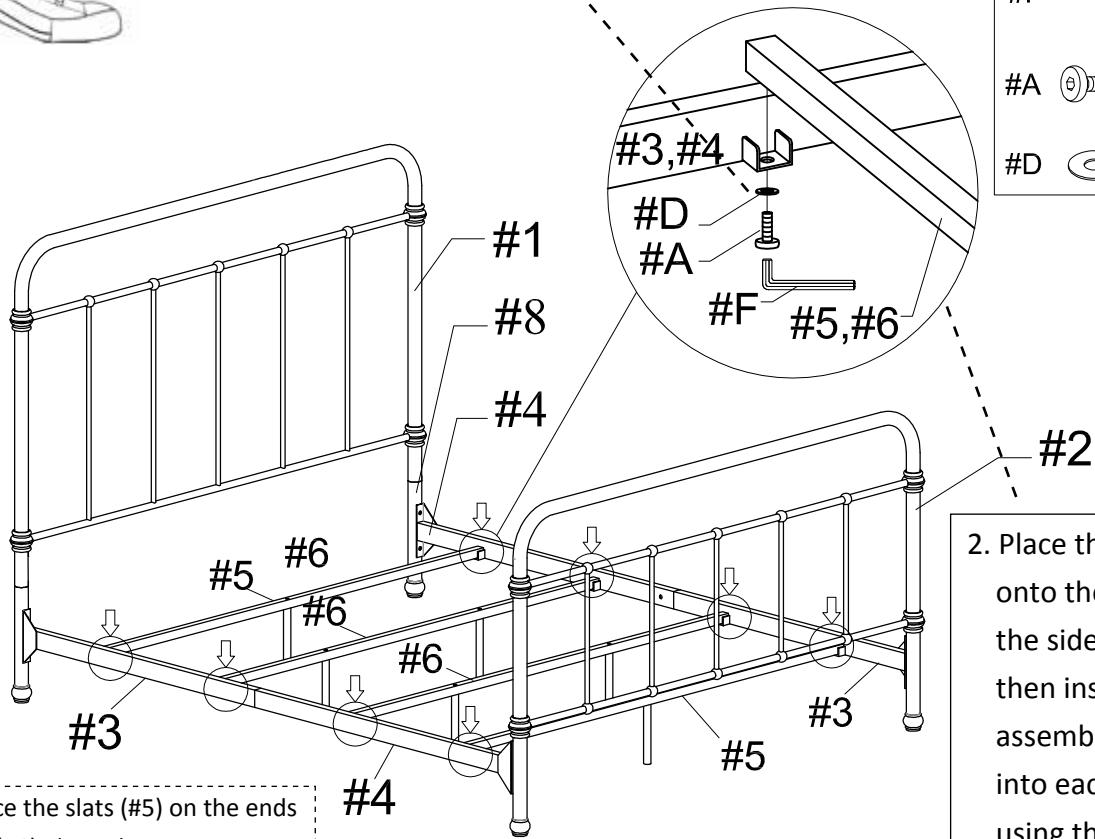
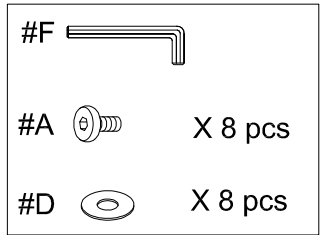

Note: Place the slats (#5) on the ends and slats (#6) along the center.

2. Place the slats (#5,6) onto the slots along the side rails (#3,4) then insert the bolt assemblies from below into each end. Secure using the Allen wrench.



Cleaning & Care

Treat surface with care. Surface is resistant to scratches but is not scratch resistant. Clean surfaces with a dry or damp soft cloth. Do not use abrasive cleaners. Hardware may loosen over time. Periodically check that all connections are tight.

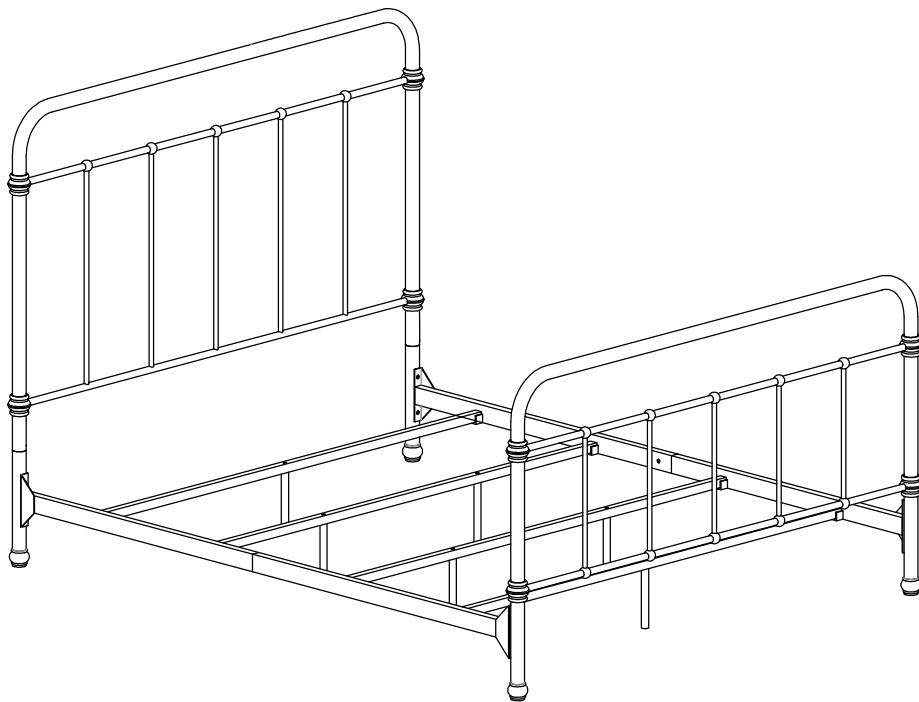

ASSEMBLY IS COMPLETED

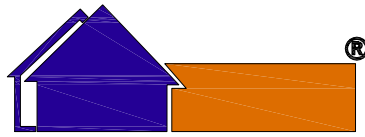

Furniture of America[®]

Assembly Instructions

CM7739CK/EK

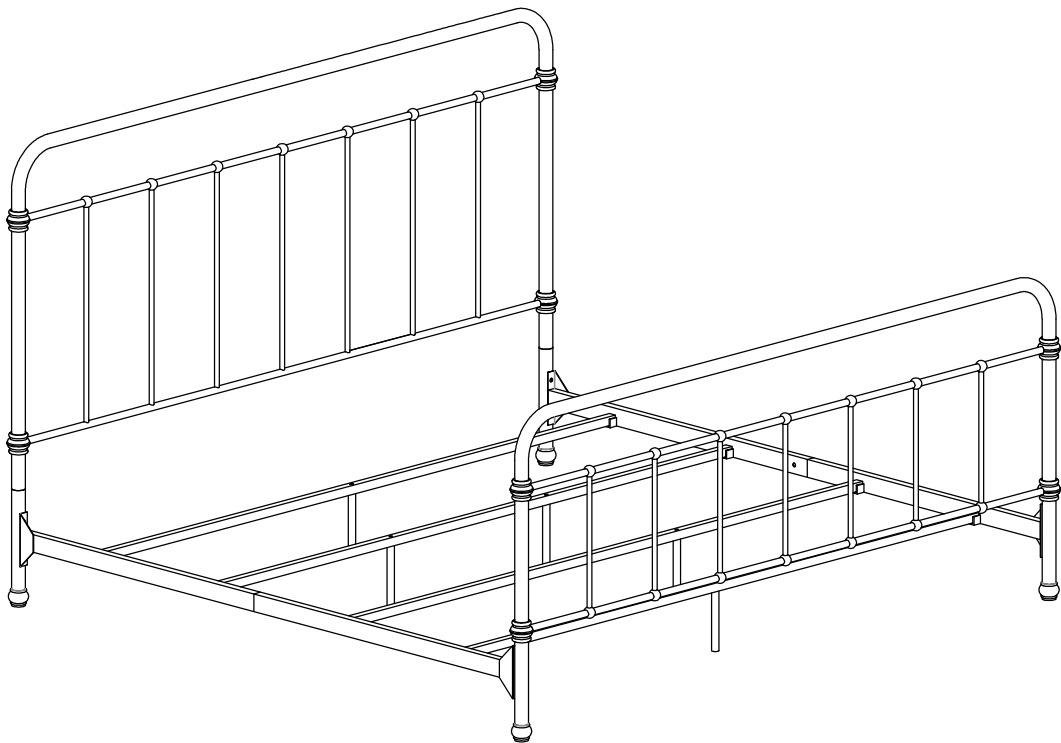

ASSEMBLY RATING

The Assembly Rating is a 5-point system that shows the degree of effort needed in assembling a specific product (with 1 being easy and 5 being difficult). For some products, two persons are recommended.

Tools Required For Assembly:

Allen Wrench



(Included)

EASY



DIFFICULT

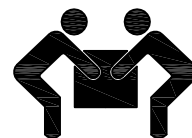

2 PERSONS RECOMMENDED

ASSEMBLY & CARE ADVICE

FOR YOUR FURNITURE TO LAST, CORRECT ASSEMBLY AND PROPER MAINTENANCE ARE NECESSARY. PLEASE FOLLOW THE INFORMATION PROVIDED BELOW TO FULLY ENJOY YOUR FURNITURE.

BASIC ASSEMBLY TECHNIQUES

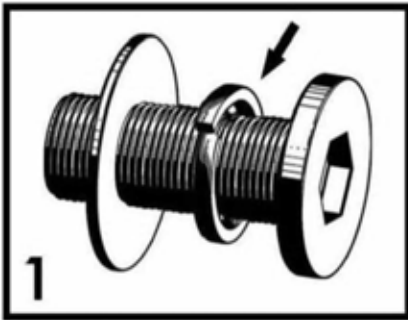

1
When lock or spring washer is used in an assembly, please make sure the lock or spring washer is placed between the larger flat washer and the head of the screw or bolt.



2
Position each part correctly and insert screws or bolts into their respective holes by hand tighten or using the proper hand tool. Only tighten when step is completed or when instructed to do so.

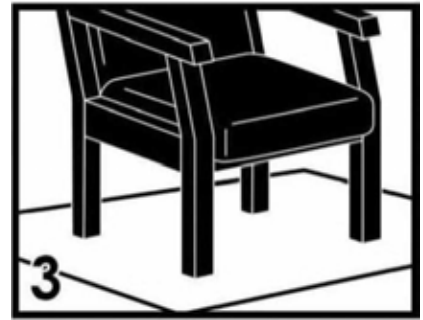

3
Use cardboard or carpet area when assembling furniture to prevent scratches. Make sure the furniture rests on a flat and level surface with each leg evenly touching the floor.

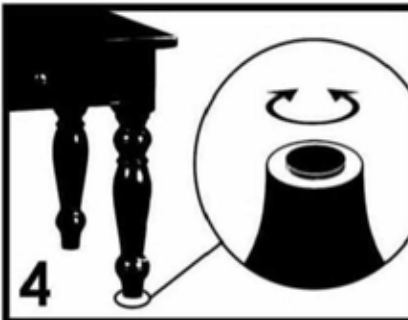

4
Some furniture comes with height adjustment knobs underneath each leg. To lower or to raise each leg, you need to turn clockwise or counterclockwise, respectively.

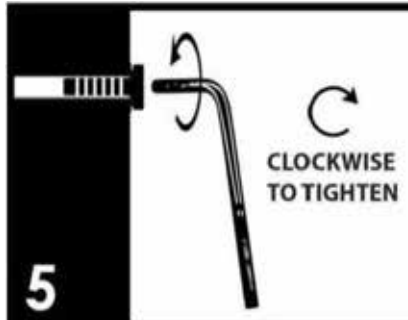

5
Make sure all parts are properly aligned, then use the appropriate hand tool to completely tighten the bolts or screws. Do not use power tools and do not overtighten.

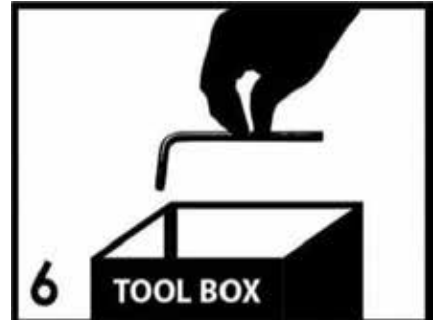

6
Save the instructions and store the Allen wrench or any supplied tool for later maintenance. After two weeks, check and tighten any loose hardware and repeat again every six months thereafter.

IT IS THE USER'S RESPONSIBILITY TO MAINTAIN THE FURNITURE. THE HARDWARE MAY LOOSEN OVER TIME AND MAY CAUSE THE FURNITURE TO BE WOBBLY AND UNABLE TO SUPPORT ITS INTENDED WEIGHT CAPACITY. THIS MAY LEAD TO COLLAPSE AND MAY CAUSE SERIOUS INJURY.

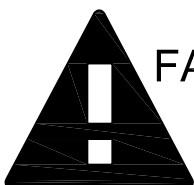

FAILURE TO FOLLOW THE GUIDELINES ABOVE MAY RESULT IN INJURY AND/OR PROPERTY DAMAGE.



Before you begin, please read Page 2 of "Assembly and Care Advice".

And remember, do not tighten until each step is completed or instructed.

Parts List

Hardware List

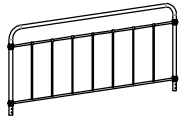

#1 x 1pc
Headboard

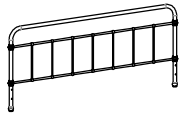

#2 x 1pc
Footboard

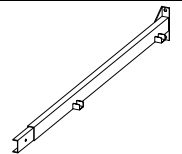

#3 x 2pcs
Side Rail

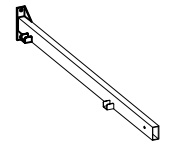

#4 x 2pcs
Side Rail

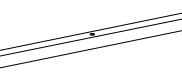

#5 x 2pcs
Slat

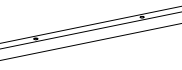

#6 x 2pcs
Slat



#7 x 6pcs
Support Leg

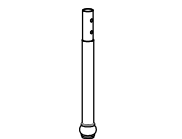

#8 x 2pcs
Extension Leg



#A x 18pcs
Bolt 1/4" X 5/8"

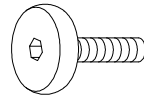

#B x 8pcs
Bolt 1/4" X 3/4"

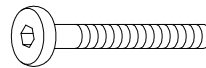

#C x 6pcs
Bolt 1/4" X 1-3/4"

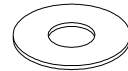

#D x 28pcs
Flat washer

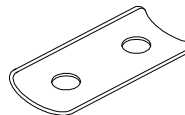

#E x 2pcs
Connecting plate



#F x 1pc
Allen Wrench



1. Insert the extension legs (#8) into the holes at the end of the headboard (#1).
2. Align a connecting plate (#E) to each end, then insert 2 bolts (#A) into each plate. Secure using the Allen wrench (#F).

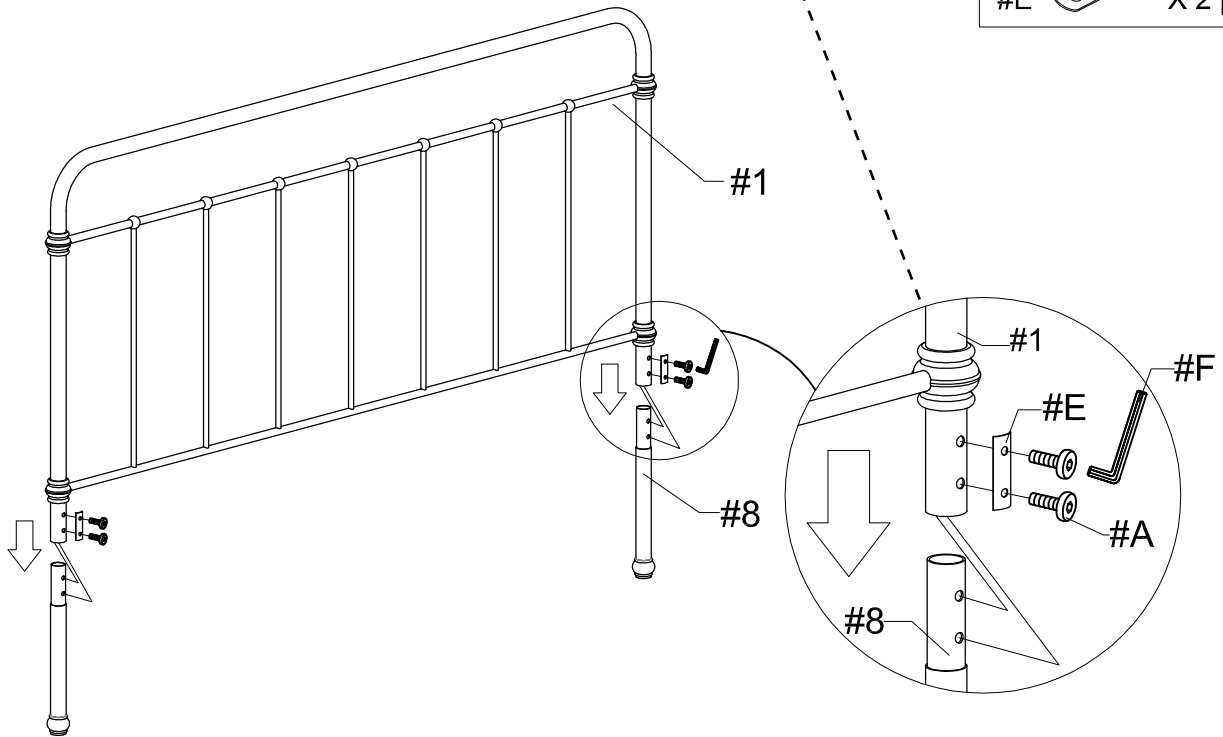
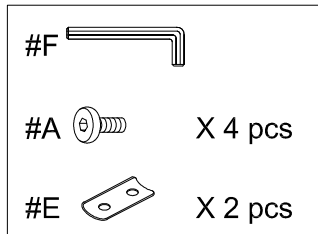

1. Insert the side rails (#3) into the side rails (#4).
2. Prepare 6 bolt assemblies by inserting a flat washer (#D) onto the bolt (#A), then insert those bolt assemblies into the holes along the center of the rails. Secure using the Allen wrench.

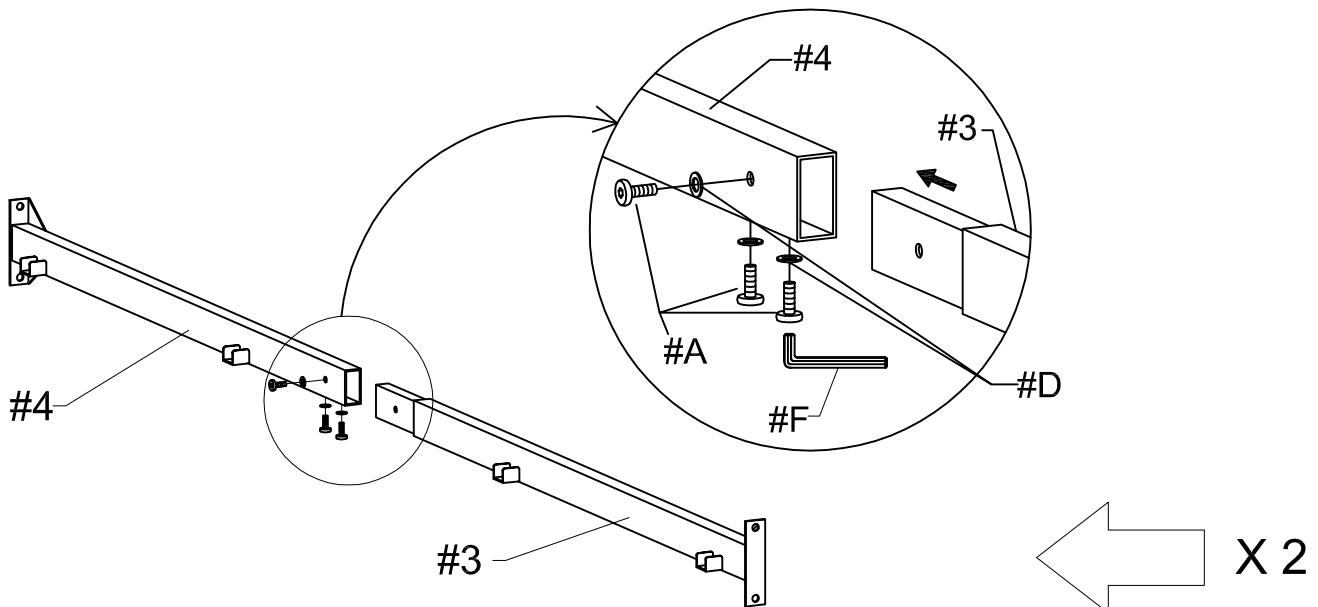
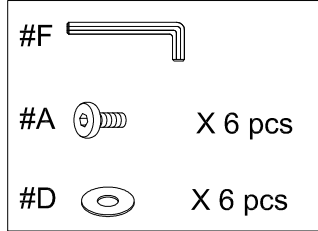



1. Prepare 6 bolt assemblies by inserting a flat washer (#D) onto the bolts (#C).



#C  X 6 pcs

#D  X 6 pcs

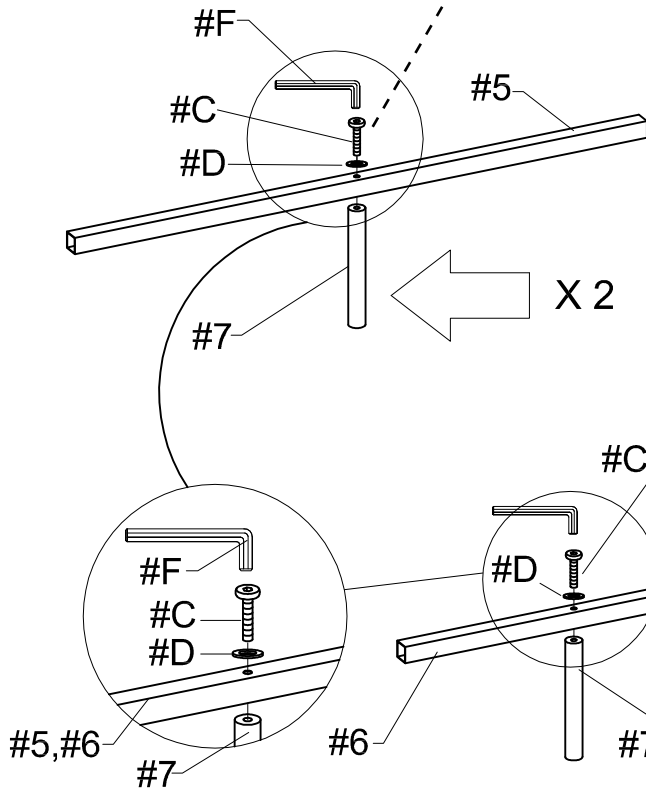

2. Align the support legs (#7) to the holes along the slats (#5,6), then insert a bolt assembly from above into each hole. Secure using the Allen wrench (#F).

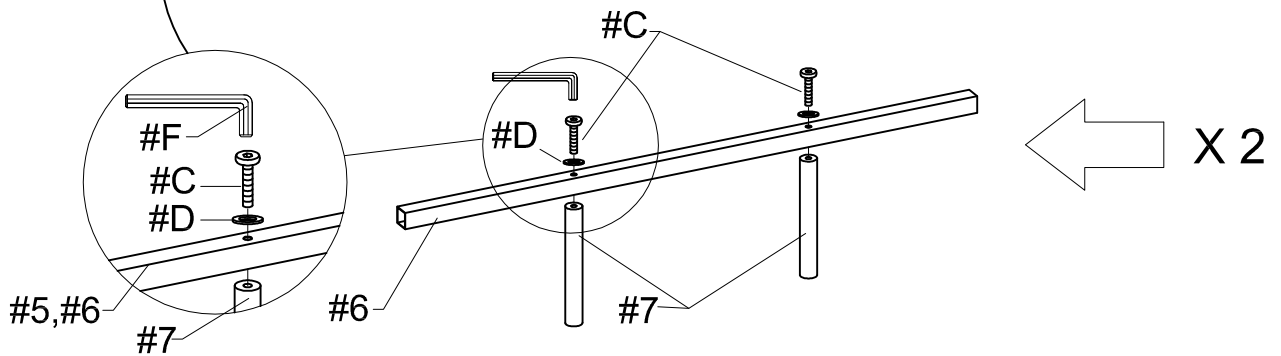

1. Prepare 8 bolt assemblies by inserting a flat washer (#D) onto the bolts (#B).



#B  X 8 pcs

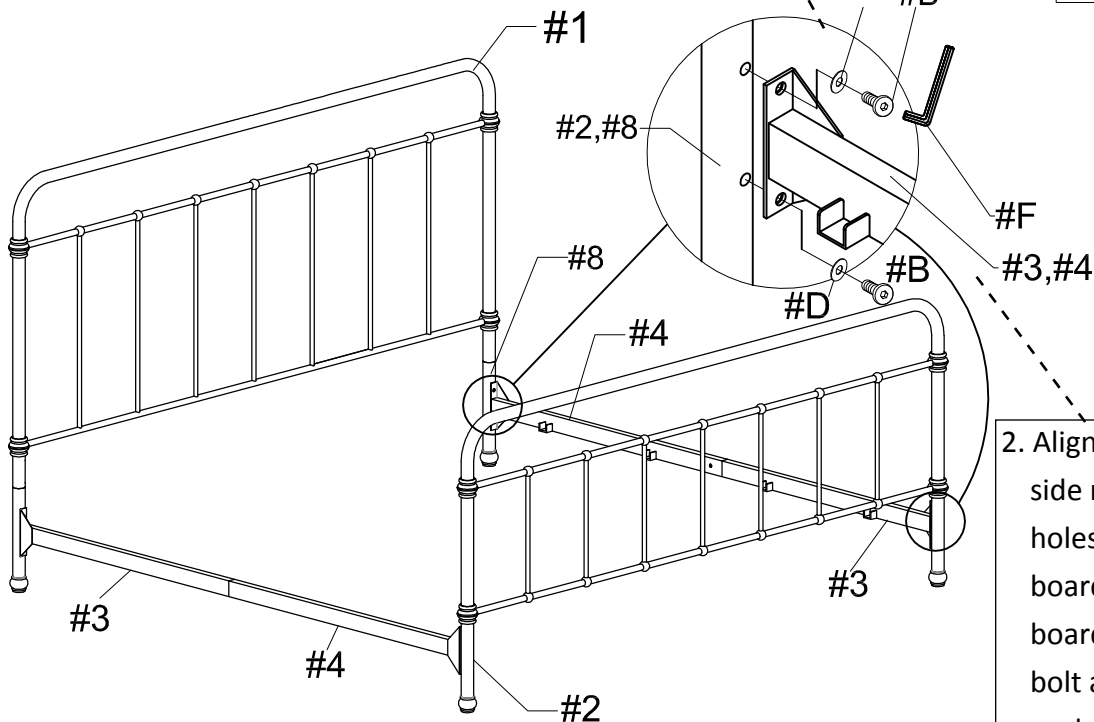

#D  X 8 pcs



2. Align the ends of the side rails (#3,4) to the holes along the headboard (#1) and footboard (#2). Insert 2 bolt assemblies into each end and secure using the Allen wrench.

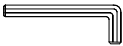

1. Prepare 8 bolt assemblies by inserting a flat washer (#D) onto the bolts (#A).

- #F 
- #A  X 8 pcs
- #D  X 8 pcs

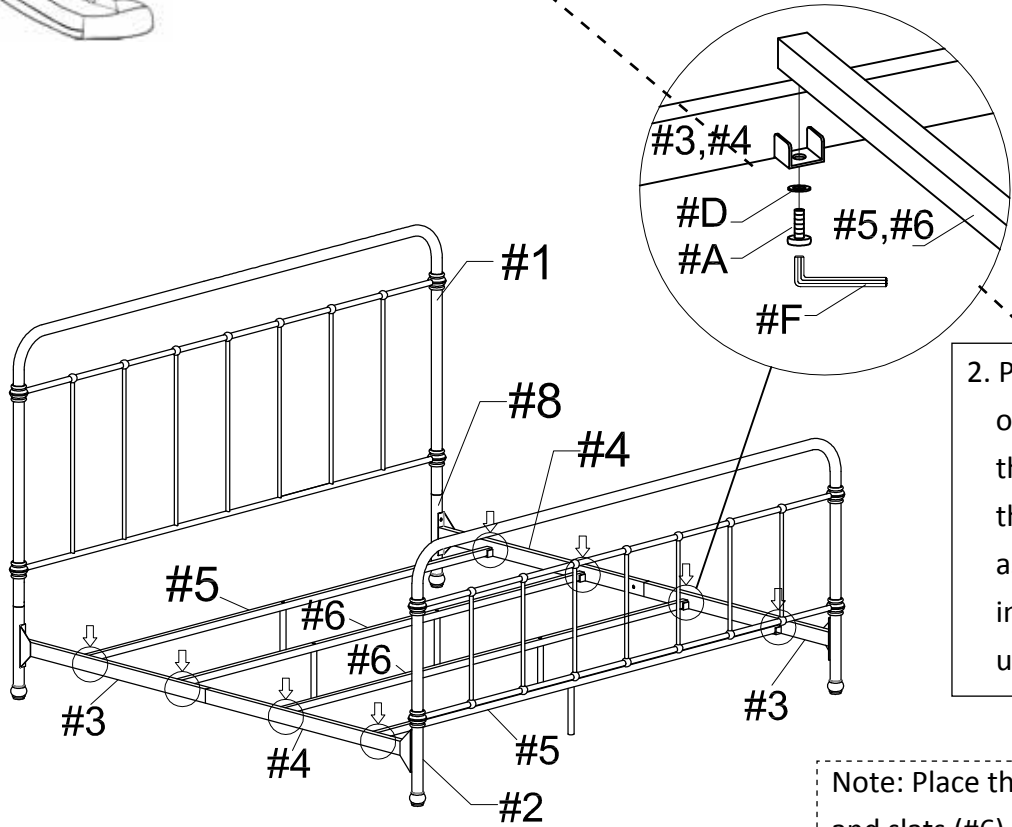

2. Place the slats (#5,6) onto the slots along the side rails (#3,4) then insert the bolt assemblies from below into each end. Secure using the Allen wrench.

Note: Place the slats (#5) on the ends and slats (#6) along the center.



Cleaning & Care

Treat surface with care. Surface is resistant to scratches but is not scratch resistant. Clean surfaces with a dry or damp soft cloth. Do not use abrasive cleaners. Hardware may loosen over time. Periodically check that all connections are tight.

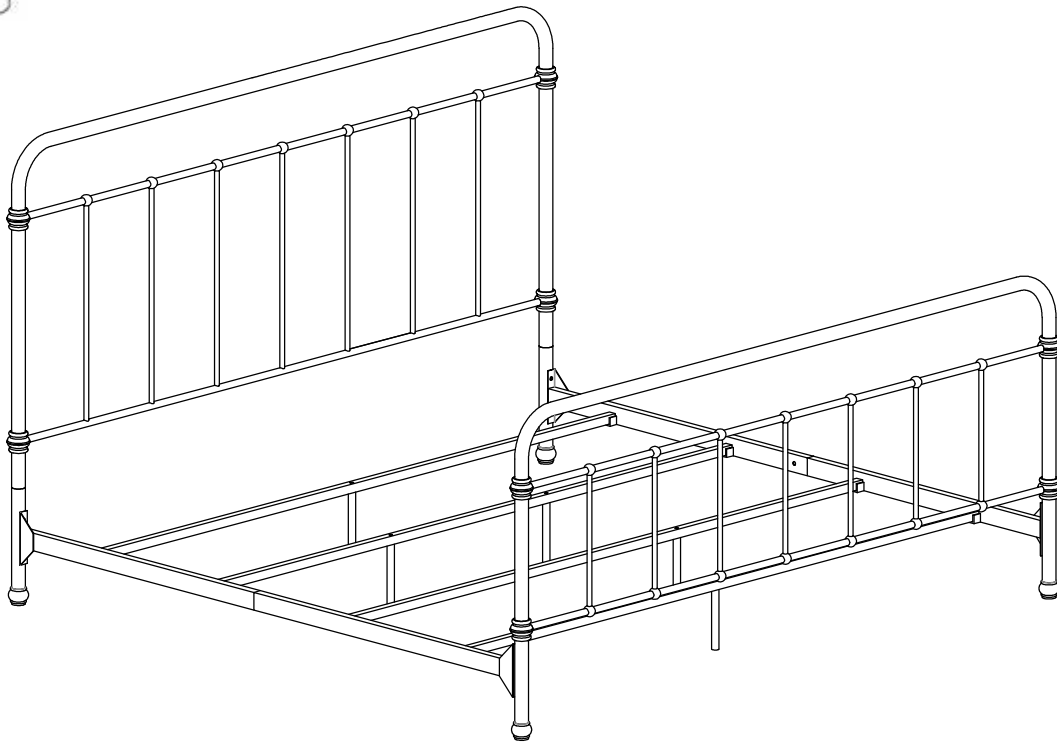

ASSEMBLY IS COMPLETED

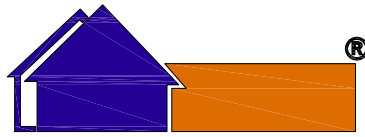

Furniture of America[®]

Assembly Instructions

CM7739T

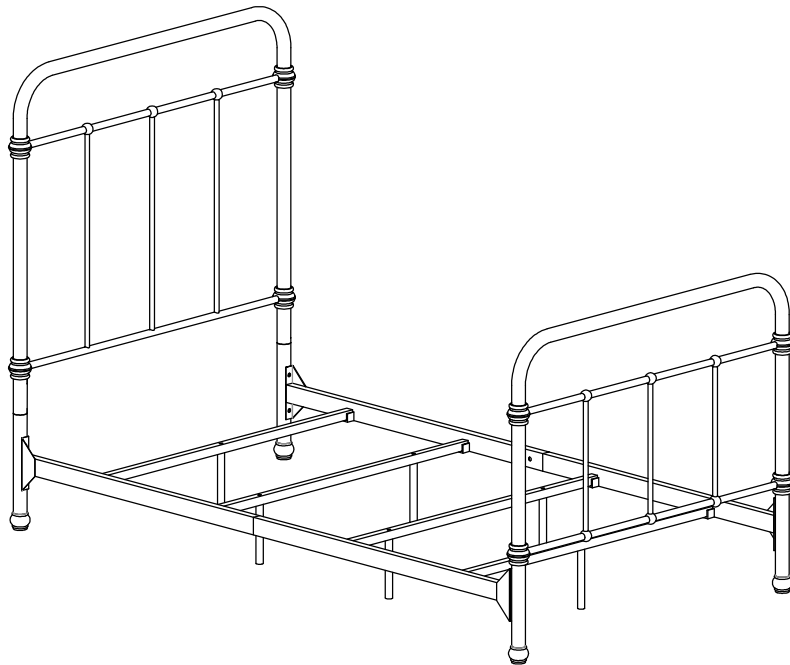

ASSEMBLY RATING

The Assembly Rating is a 5-point system that shows the degree of effort needed in assembling a specific product (with 1 being easy and 5 being difficult). For some products, two persons are recommended.

EASY



DIFFICULT

Tools Required For Assembly:

Allen Wrench



(Included)

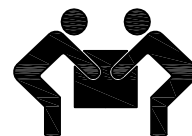

2 PERSONS RECOMMENDED

ASSEMBLY & CARE ADVICE

FOR YOUR FURNITURE TO LAST, CORRECT ASSEMBLY AND PROPER MAINTENANCE ARE NECESSARY. PLEASE FOLLOW THE INFORMATION PROVIDED BELOW TO FULLY ENJOY YOUR FURNITURE.

BASIC ASSEMBLY TECHNIQUES

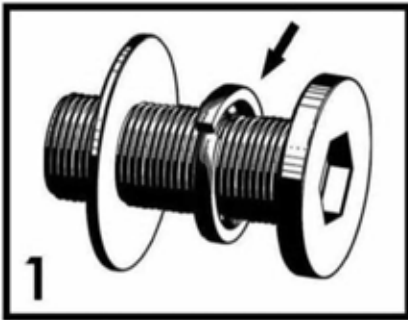

When lock or spring washer is used in an assembly, please make sure the lock or spring washer is placed between the larger flat washer and the head of the screw or bolt.



Position each part correctly and insert screws or bolts into their respective holes by hand tighten or using the proper hand tool. Only tighten when step is completed or when instructed to do so.



Use cardboard or carpet area when assembling furniture to prevent scratches. Make sure the furniture rests on a flat and level surface with each leg evenly touching the floor.

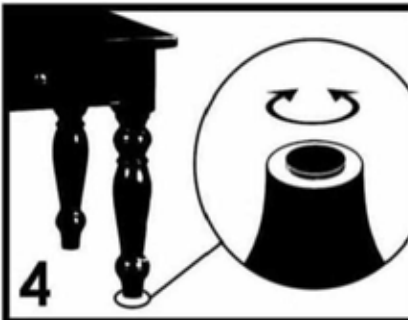

Some furniture comes with height adjustment knobs underneath each leg. To lower or to raise each leg, you need to turn clockwise or counterclockwise, respectively.

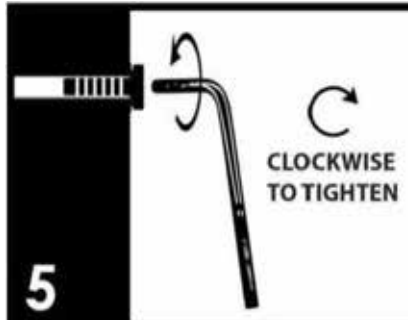

Make sure all parts are properly aligned, then use the appropriate hand tool to completely tighten the bolts or screws. Do not use power tools and do not overtighten.

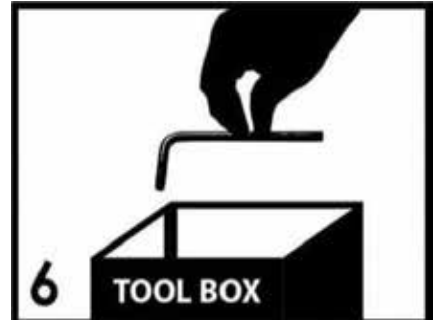

Save the instructions and store the Allen wrench or any supplied tool for later maintenance. After two weeks, check and tighten any loose hardware and repeat again every six months thereafter.

IT IS THE USER'S RESPONSIBILITY TO MAINTAIN THE FURNITURE. THE HARDWARE MAY LOOSEN OVER TIME AND MAY CAUSE THE FURNITURE TO BE WOBBLY AND UNABLE TO SUPPORT ITS INTENDED WEIGHT CAPACITY. THIS MAY LEAD TO COLLAPSE AND MAY CAUSE SERIOUS INJURY.

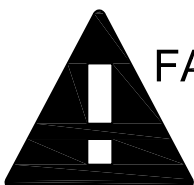

FAILURE TO FOLLOW THE GUIDELINES ABOVE MAY RESULT IN INJURY AND/OR PROPERTY DAMAGE.



Before you begin, please read Page 2 of "Assembly and Care Advice".

And remember, do not tighten until each step is completed or instructed.

Parts List



#1 x 1pc
Headboard



#2 x 1pc
Footboard

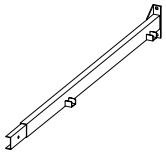

#3 x 2pcs
Side Rail

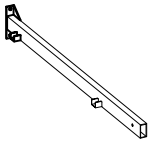

#4 x 2pcs
Side Rail

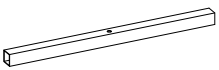

#5 x 2pcs
Slat

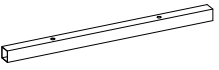

#6 x 2pcs
Slat



#7 x 6pcs
Support Leg



#8 x 2pcs
Extension Leg

Hardware List



#A x 18pcs
Bolt 1/4" X 5/8"

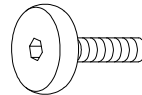

#B x 8pcs
Bolt 1/4" X 3/4"

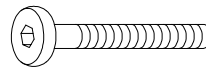

#C x 6pcs
Bolt 1/4" X 1-3/4"



#D x 28pcs
Flat washer

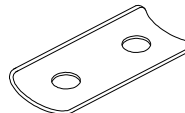

#E x 2pcs
Connecting plate



#F x 1pc
Allen Wrench



1. Insert the extension legs (#8) into the holes at the end of the headboard (#1).
2. Align a connecting plate (#E) to each end, then insert 2 bolts (#A) into each plate. Secure using the Allen wrench (#F).

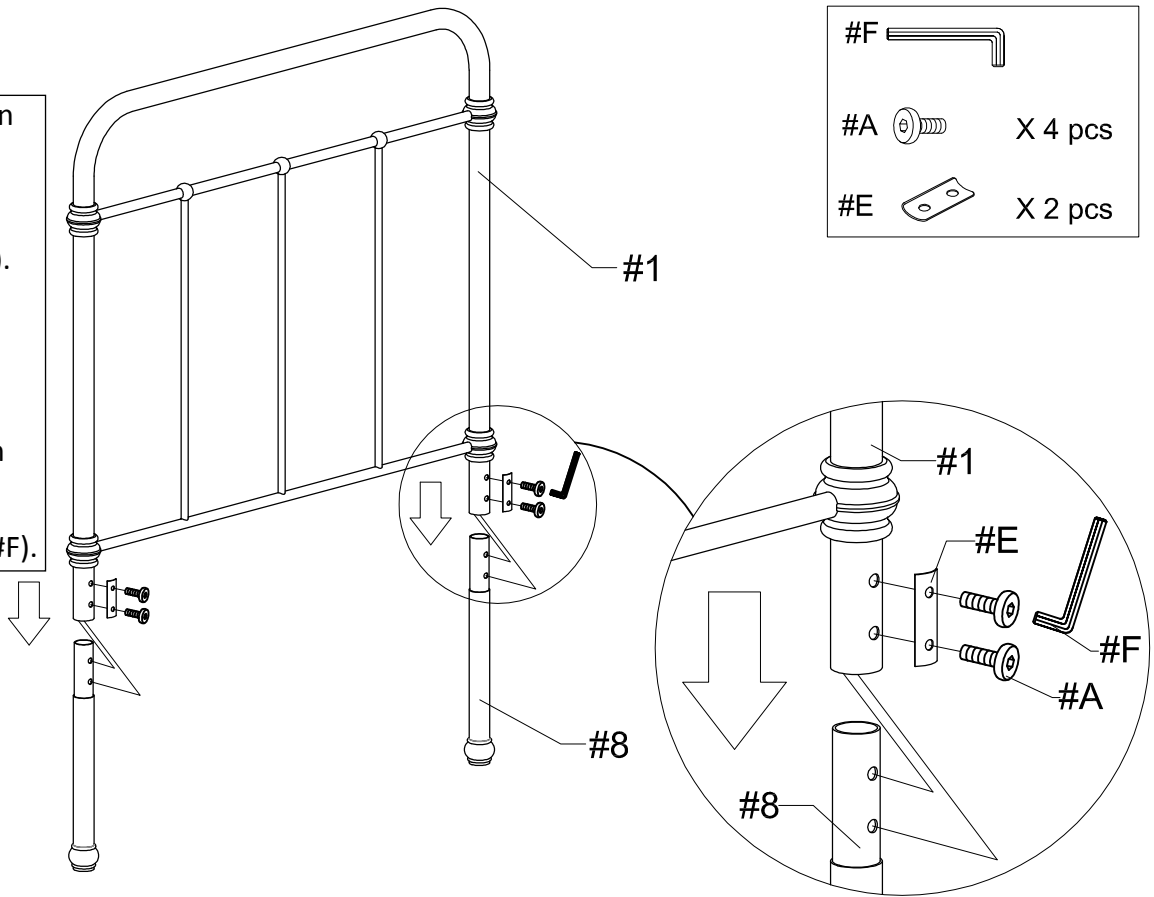

#F		
#A		X 4 pcs
#E		X 2 pcs



1. Insert the side rails (#3) into the side rails (#4).
2. Prepare 6 bolt assemblies by inserting a flat washer (#D) onto the bolt (#A), then insert those bolt assemblies into the holes along the center of the rails. Secure using the Allen wrench.

#F		
#A		X 6 pcs
#D		X 6 pcs

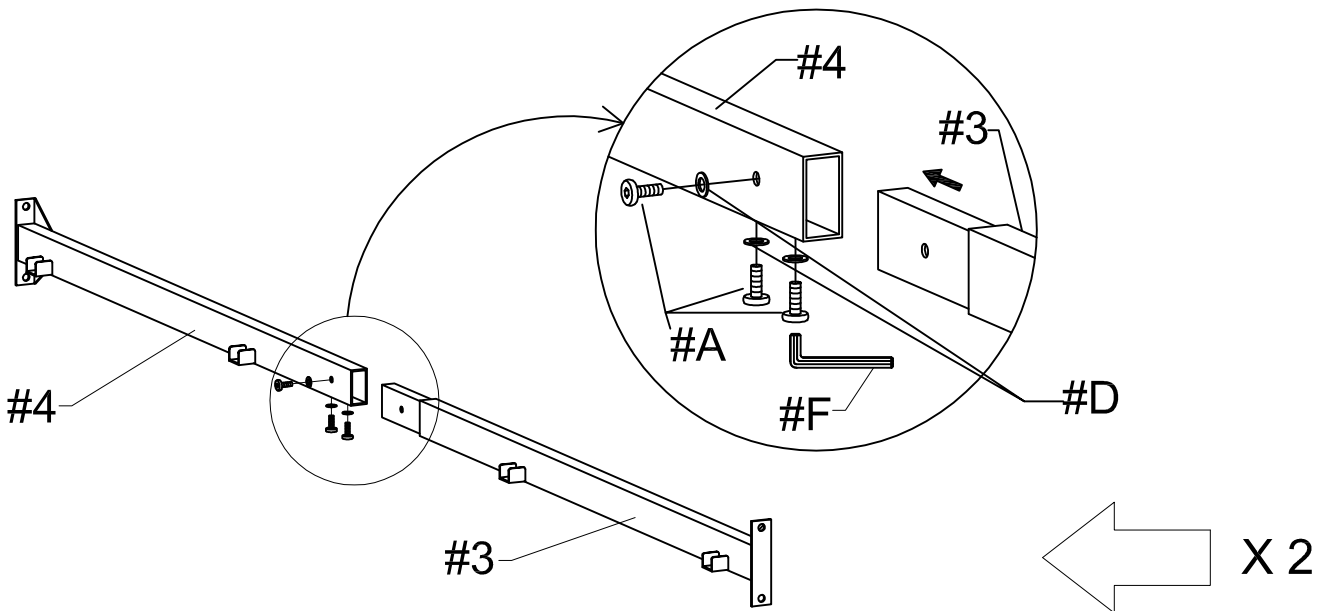



1. Prepare 6 bolt assemblies by inserting a flat washer (#D) onto the bolts (#C).

#F		
#C		X 6 pcs
#D		X 6 pcs

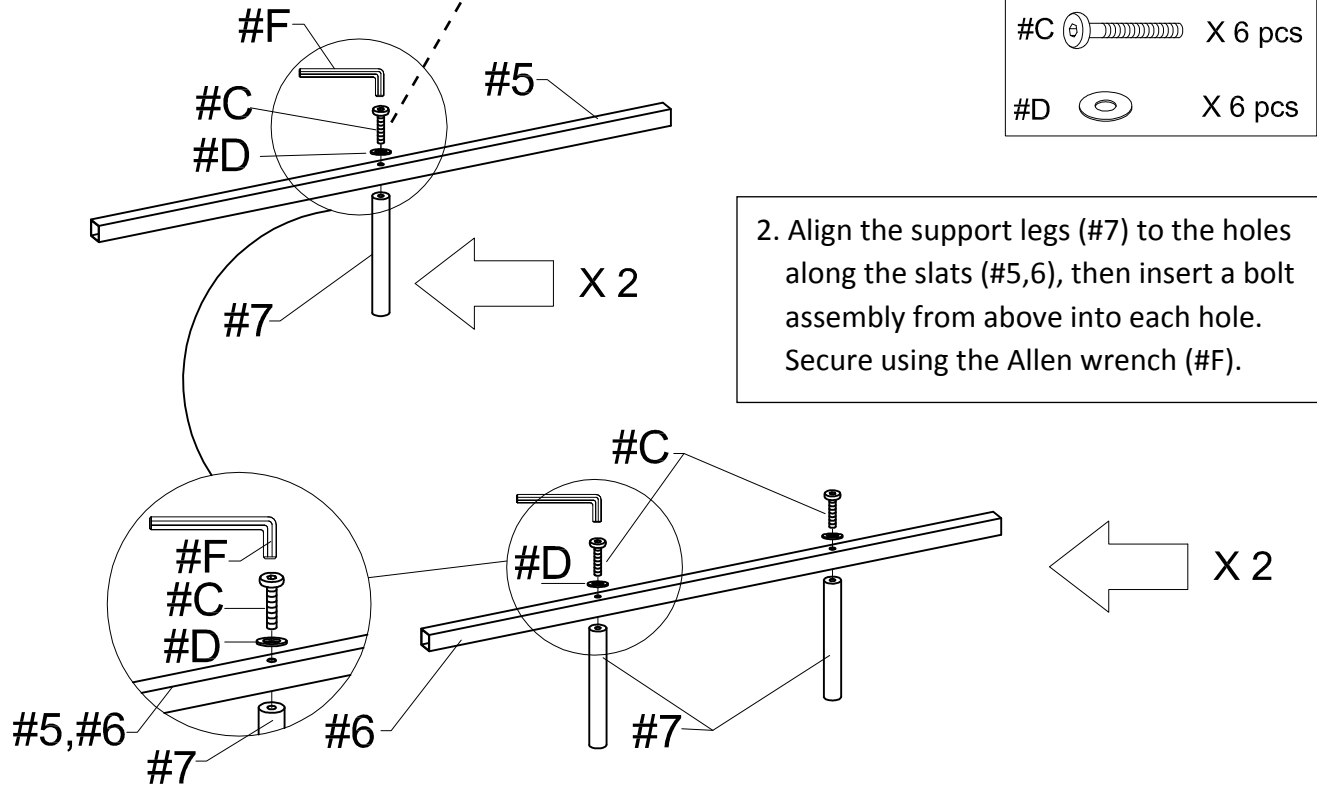

1. Prepare 8 bolt assemblies by inserting a flat washer (#D) onto the bolts (#B).

#F		
#B		X 8 pcs
#D		X 8 pcs

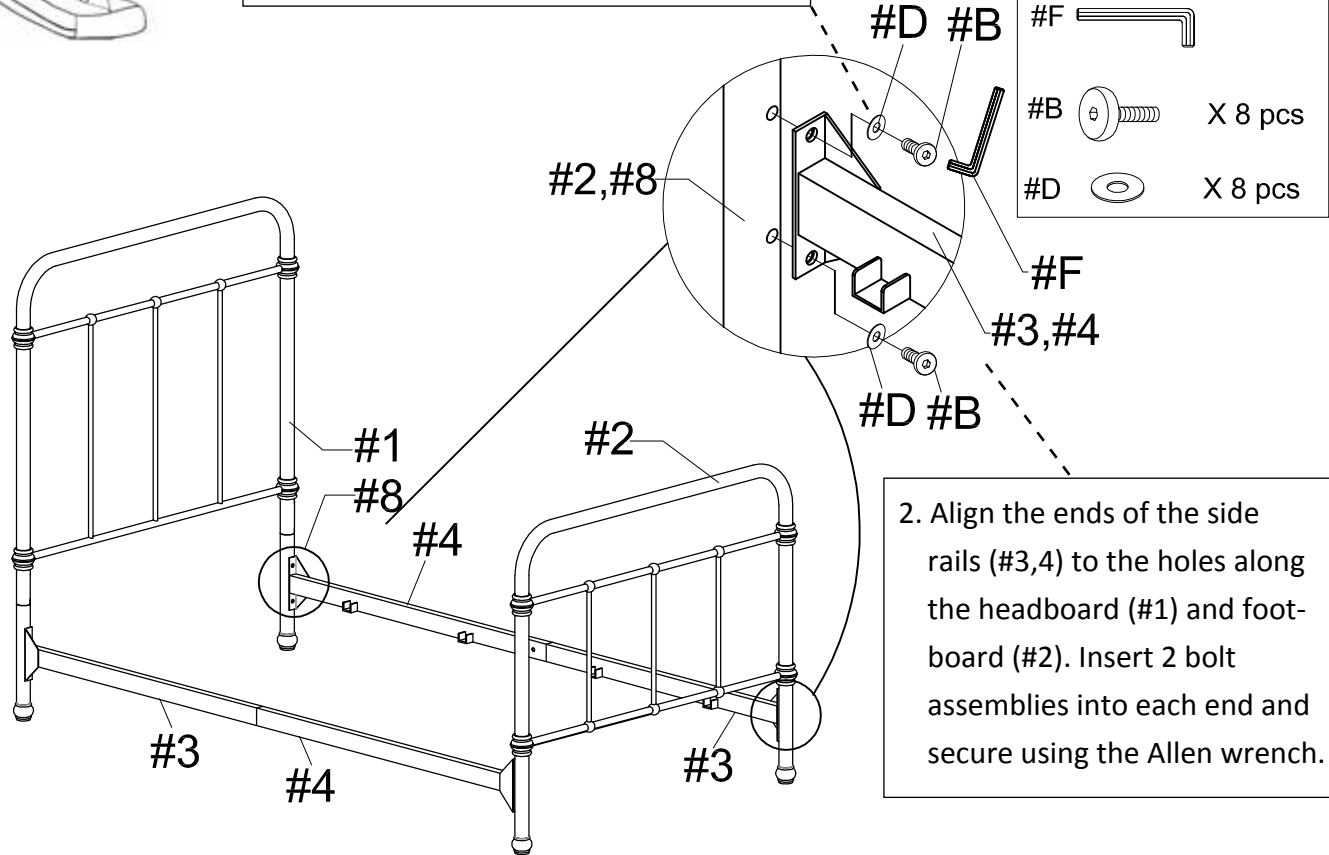



1. Prepare 8 bolt assemblies by inserting a flat washer (#D) onto the bolts (#A).

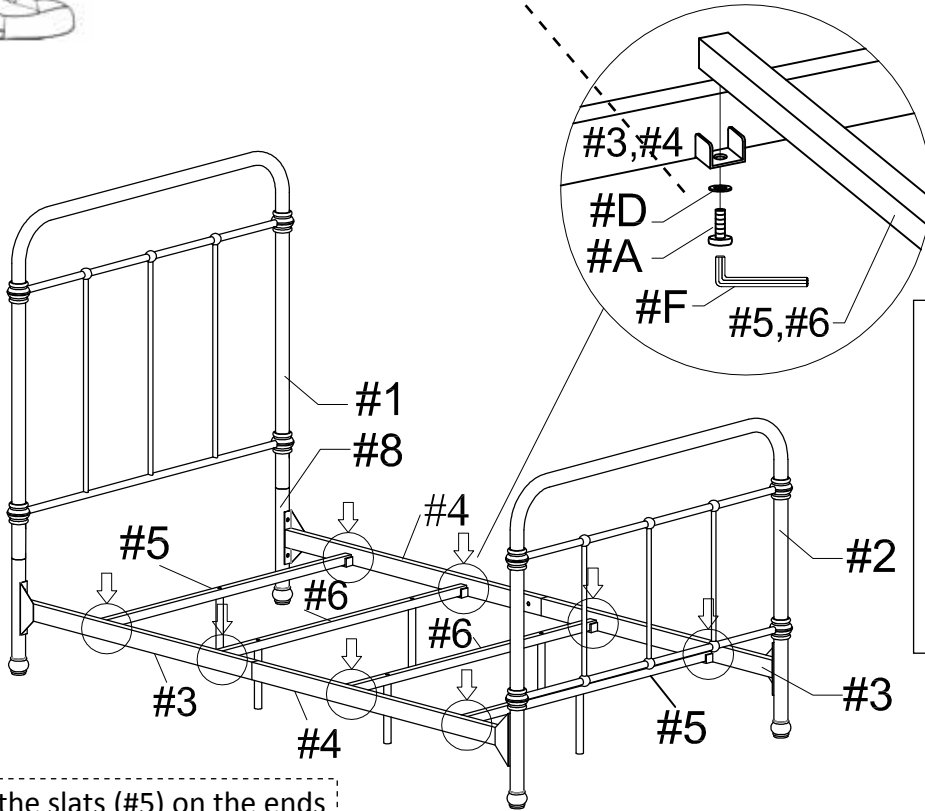
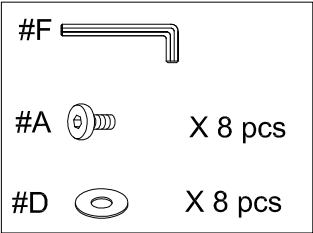

2. Place the slats (#5,6) onto the slots along the side rails (#3,4) then insert the bolt assemblies from below into each end. Secure using the Allen wrench.

Note: Place the slats (#5) on the ends and slats (#6) along the center.



Cleaning & Care

Treat surface with care. Surface is resistant to scratches but is not scratch resistant. Clean surfaces with a dry or damp soft cloth. Do not use abrasive cleaners. Hardware may loosen over time. Periodically check that all connections are tight.

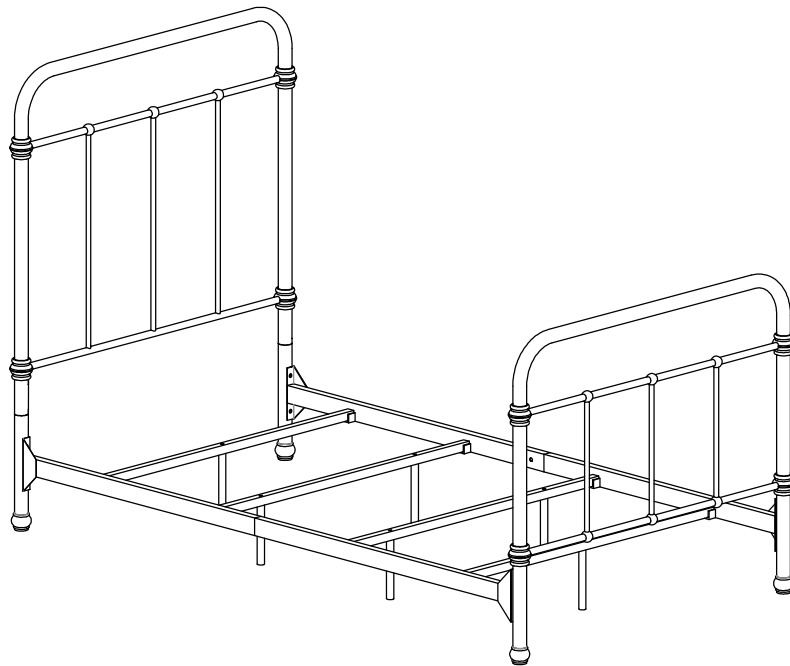

ASSEMBLY IS COMPLETED