



36" Unframed Electric Cooktop

With Wolf's unframed electric cooktops there's no stainless steel trim, just the sophisticated, minimalist exterior subtly patterned design to hide any unsightly scratches. Four heating elements with nine zones offer exceptional control of temperature for cooking utensils of every size. A bridge connects two elements for a 7-inch by 16-inch, 4400 watt heating area. All elements offer true simmer along with one element that enables you to set the temperature for melting.



Model CT36EU in flush mounted installation.

FEATURES

- Can be mounted flush with top of countertop or as a frameless installation sitting on top of the countertop surface.
- Easy-to-clean black ceramic glass surface is resistant to scratching, staining, impact and heat—translucent surface allows you to see the glow of hot elements.
- High-frequency pulsation elements improve cooking performance and control.
- Four heating elements with nine zones.
- Bridge-zone element connects two elements to provide a larger cooking area.
- Temperature limiter to ensure that safe operating temperature of ceramic glass is never exceeded.
- Illuminated touch controls with graduated control lighting.
- True simmer setting on all elements.
- Melt setting on one element.
- Hot-surface indicator light in control panel.
- Lock mode—cooktop can be locked so that no elements can be turned on.
- Universal OFF turns all elements off.
- Countdown timer with 1 to 99 minute range and adjustable sound frequency and volume.

MAXIMUM ELEMENT POWER

- Triple-zone element power: 1050 W/2200 W/2700 W.
- Dual-zone element power: 700 W/2200 W.
- Single element power: 1200 W.
- Bridge-zone element power—(2) 1800 W single elements with 800 W bridge: 4400 W.

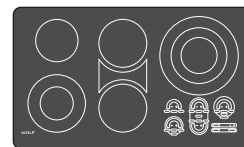

Model CT36EU



This appliance is certified by Star-K to meet strict religious regulations in conjunction with specific instructions found on www.star-k.org.



Touch controls.

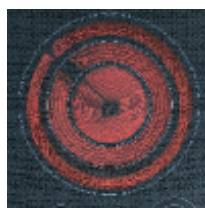

Translucent surface.



36" Unframed Electric Cooktop

OVERALL DIMENSIONS

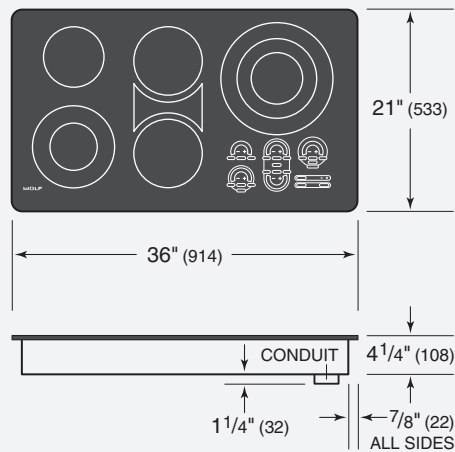

Unit dimensions may vary by $\pm 1/8"$.

SPECIFICATIONS

Overall Width	36"
Overall Height	4 1/4"
Overall Depth	21"
Heating Zone Outer Diameter	
(1) Triple	12"
(1) Dual	8 1/4"
(3) Single	(2) 7" and 6 1/2"
Bridge Element Dimensions	7" x 16"
Countertop Cut-Out	34 3/8" W x 19 3/8" D
Electrical Requirements	240/208 V AC, 60 Hz 50 amp service
Conduit	4" flexible 3-wire
Electric Rating	10.5 kW at 240 V AC 7.9 kW at 208 V AC
Shipping Weight	60 lbs

INSTALLATION SPECIFICATIONS

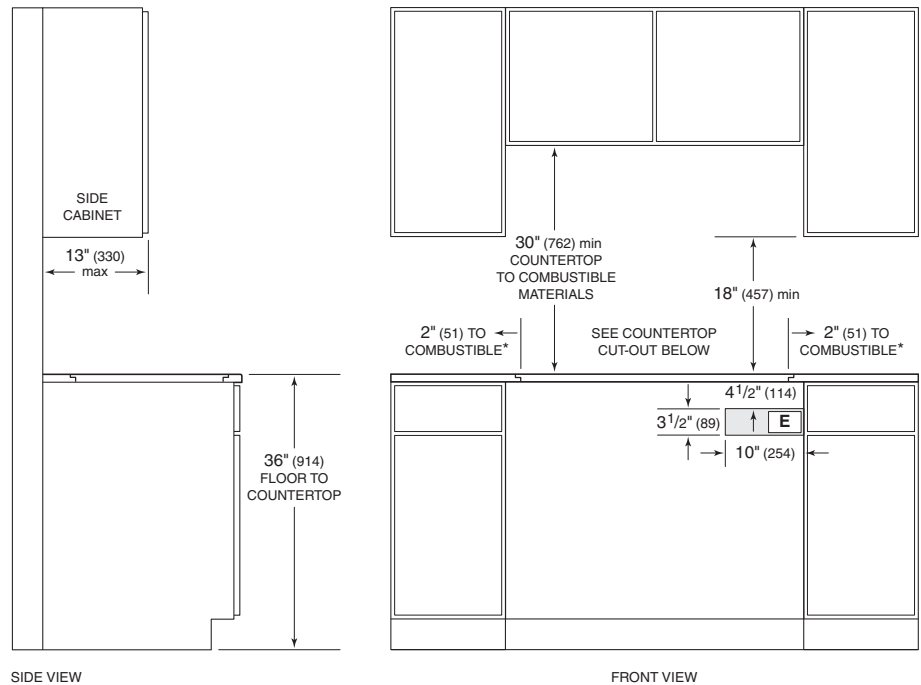

*Minimum clearance from cooktop cut-out to combustible materials up to 18" (457) above countertop.

NOTE: Electrical location applies only to installation with built-in oven.

INSTALLATION NOTES

Complete installation specifications can be found on our website, wolfappliance.com.

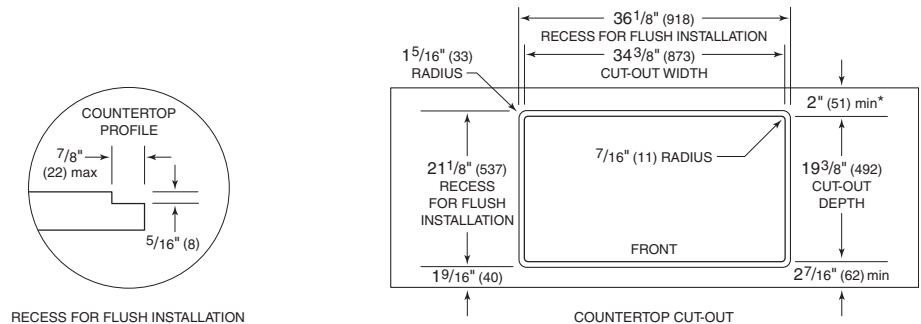

RECESS FOR FLUSH INSTALLATION

Dimensions in parentheses are in millimeters unless otherwise specified.