

PERFORMANCE DATA NO LOAD & NO DOOR OPENINGS AT MID-POINT CONTROL SETTING				
CD 18' & SD 18'			SD 20'	
Type A With Run/ Start Capacitor	70°F	90°F	70°F	90°F
Operating Time	24 to 30%	40 to 45%	24 to 30%	46 to 51%
Fresh Food Temperature	33 to 39	35 to 41	33 to 39	
Freezer Temperature	4° to -4°F	2° to -6°F	2 to -6	0 to -8
Low Side Pressure (cut-in)	0.26 to 1.22 psig	-0.37 to 0.97 psig	0.00 to 0.50 psig	-1.10 to -0.32 psig
Low Side Pressure (cut-out)	-6.92 to -7.33 psig	-6.63 to -7.23 psig	-7.60 to -7.20 psig	-7.40 to -7.10 psig
High Side Pressure (last 1/3 cycle)	38 to 41 psig	53 to 59 psig	40 to 50 psig	54 to 64 psig
Wattage (last 1/3 cycle)	87W	90W	82W	90W
Amps (running)	0.67 to 0.87 A	0.70 to 0.90 A	0.64 to 0.84 A	0.70 to 0.90 A
Base Voltage	115V			
Refrigerant Charge	40 g			

DEFROST SPECIFICATIONS				
Cabinet Size: 18'	Thermal Fuse	Heater		Defrost Thermistor
	Cut-out	Watts	Ohms	Termination
CD 18', SD 18', SD 20'	161.6°F (72°C)	178	79.7	50°F (10°C)

ICE MAKER SPECIFICATIONS		
Electrical	115 vac (127 vac max)	60 Hertz

ICE MAKER CONNECTOR PLUG CONNECTIONS		
Wire Number	Wire Color	Connects to:
1	Light Blue	Neutral
2	Yellow	Water Valve
3	Black	Line

SERVICE DATA SHEET

A16319701

STANDARD - AUTOMATIC DEFROST TOP MOUNT FREEZER - R600a

IMPORTANT SAFETY NOTE

The information provided herein is designed to assist qualified repair personnel only. Untrained persons should not attempt to make repairs due to the possibility of electrical shock. Disconnect power cord before servicing this appliance.

IMPORTANT

If any green grounding wires are removed during servicing, they must be returned to their original position and properly secured.

⚠ CAUTION

All electrical parts and wiring must be shielded from torch flame. DO NOT allow torch to touch insulation; it will char at 200°F and flash ignite (burn) at 500°F. Excessive heat will distort the plastic liner.

MANUAL DEFROST	
Unit will complete normal defrost cycle.	
enter	--> Press the FF door switch 5 times in 2 secs.
exit	--> Cycle power to the unit or enter and exit SERVICE MODE. (See SERVICE MODE)
Defrost is terminated when defrost thermistor located on the evaporator coil reaches 50°F (10°C).	

IMPORTANT

START-UP NOTE: Upon 1st start-up or power cycle, the compressor will come on after 20 seconds and run for 5 minutes. If the door switch is not cycled during this time, the compressor may cut off after 5 minutes and not turn back on for another 3 minutes. It may take up to 10 minutes for the compressor to turn on and run in normal mode.

IMPORTANT

PLEASE RETURN THIS SHEET TO ITS ORIGINAL LOCATION.

SERVICE MODE		
SERVICE MODE will step through available tests to diagnose individual electrical circuits. Fresh Food compartment light will be OFF while in SERVICE MODE.		
enter/exit	--> Press the door switch 3 times and hold the 4th press until the FF light turns on. When switch is released the light should turn off. The door switch must be pressed 4 times in 2 seconds.	
initiate/ next test	--> Press the door switch 2 times.	
1	Compressor	In each test, the component listed will be powered on. The component will stay powered until the next test is activated, or until 10 minutes of inactivity expire. Listen for operating sounds; feel for heat or air flow, as appropriate, to determine the result of each test. Press the FF door switch twice again to advance between tests.
2	Heater	
3	FF Light	
4	Evaporator Fan	

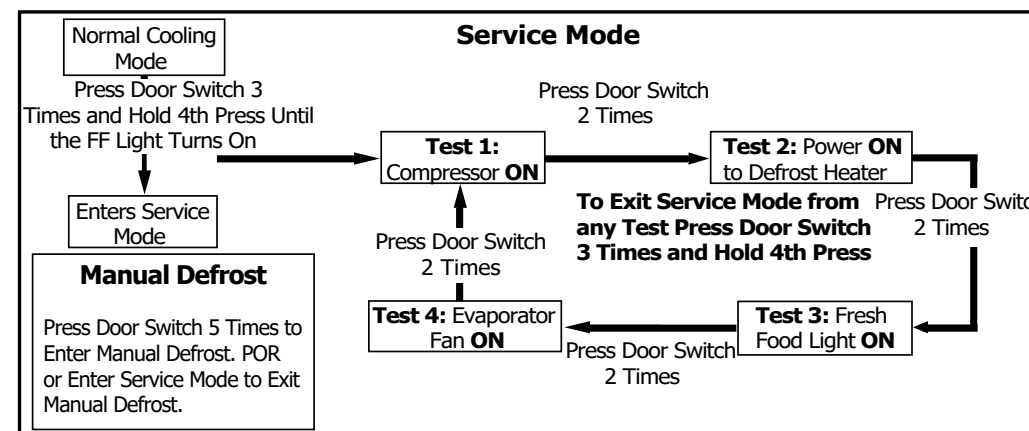

ICE MAKER INFORMATION

Turn the IM ON and OFF: Press and hold the POWER button for ½ second to turn the IM ON and OFF. When the IM is ON, the Power button will be illuminated solid green

Test Cycling: Press and release the TEST/SERVICE button to start the self-diagnostic function. The tray will perform two rotations. The ice level arm must be held so that it does not drop during the first rotation (simulating full ice bin). Once the tray returns to the Home position, the arm can be released. Allow the arm to drop normally during the second rotation (simulating empty ice bin). Once the tray returns Home after the second rotation, the POWER button will change back to solid green if no errors were detected during the test. This means the IM operates properly. If errors are detected at any time during the test, the test will stop immediately and the POWER button will blink rapidly continuously. In this case, there is some internal failure of the IM. **NOTE: If the arm is not held during the first rotation, the IM will indicate a failure falsely.** To run the test again to verify, the IM must be turned OFF and back ON.

Manual Water Fill: Press and hold the TEST/SERVICE button for 3+ seconds.

Adjust Water Fill Size: Press and hold the POWER and TEST/SERVICE buttons together for 3 seconds. The POWER button will blink to show the current setting.

1 blink = small, 2 blinks = med, 3 blinks = large, 4 blinks = extra large. Press the TEST/SERVICE button to advance to the next level. When at extra large, the next press goes back to small. The factory default is small.

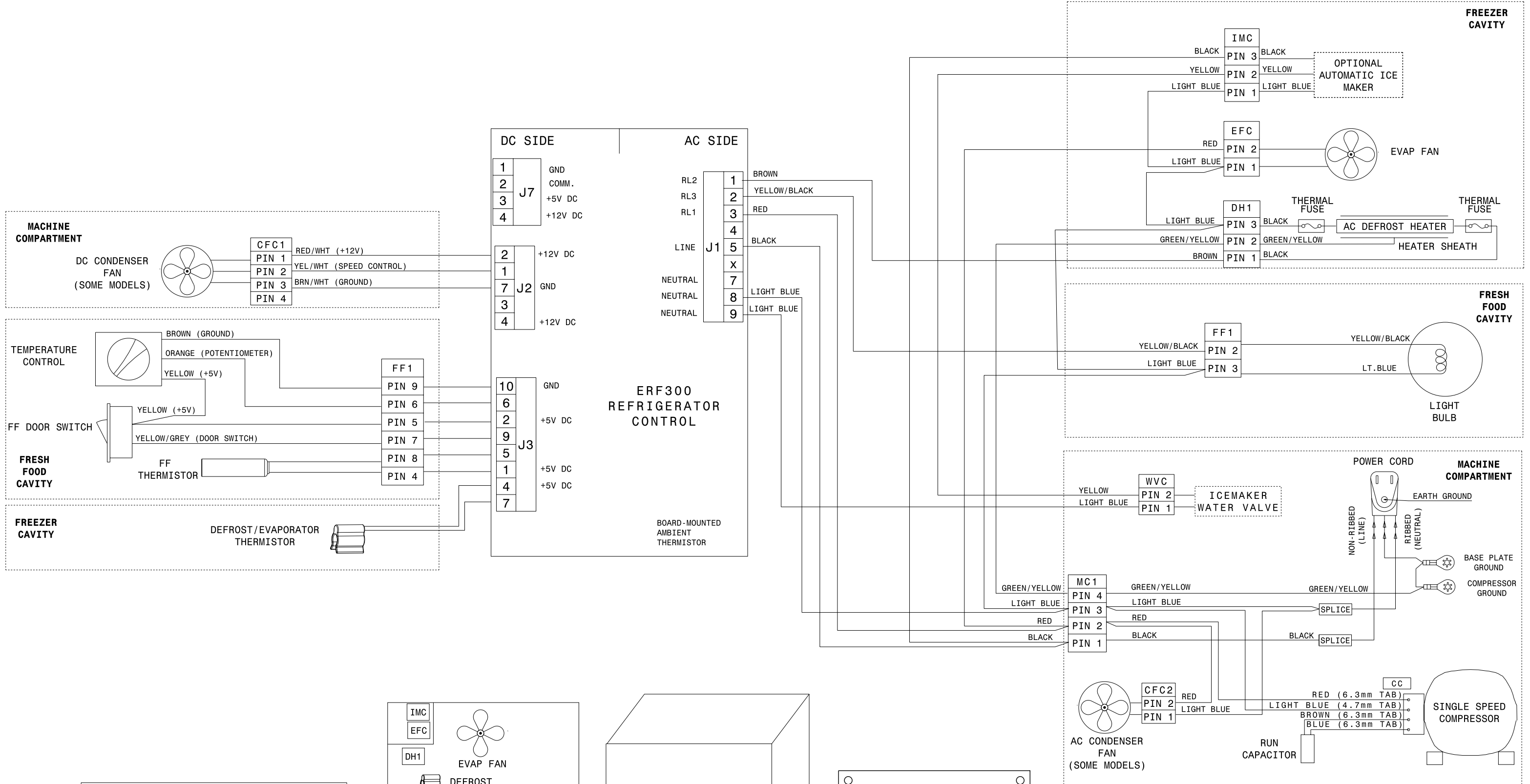

INLINE CONNECTOR ABBREVIATION KEY	
ABBREVIATION	EXPLANATION
MC1	4 PIN CONNECTION ABOVE COMPRESSOR IN MACHINE COMPARTMENT
FF1	9 PIN CONNECTION IN CONTROL BOX
CC	4 TERMINAL CONNECTIONS TO COMPRESSOR
CFC1	4 PIN CONNECTION TO DC CONDENSER FAN
CFC2	2 PIN CONNECTION TO AC CONDENSER FAN
WVC	2 PIN CONNECTION TO ICE MAKER WATER VALVE
IMC	3 PIN ICE MAKER CONNECTION IN FREEZER
EFC	2 PIN EVAPORATOR FAN CONNECTION IN FREEZER
DH1	3 PIN DEFROST HEATER CONNECTION IN FREEZER BEHIND COIL COVER

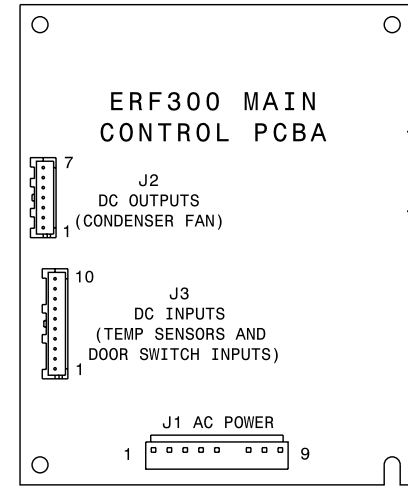
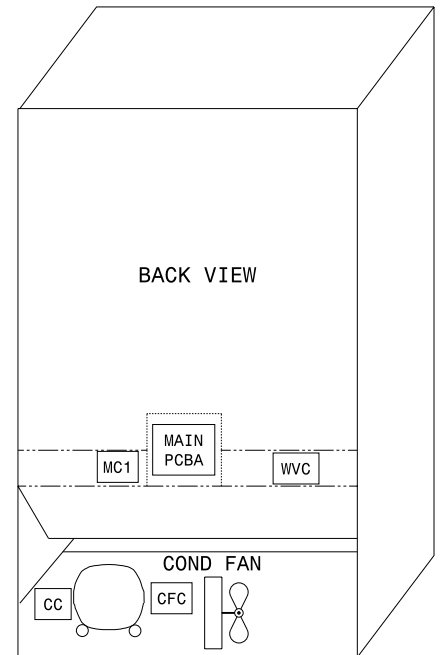
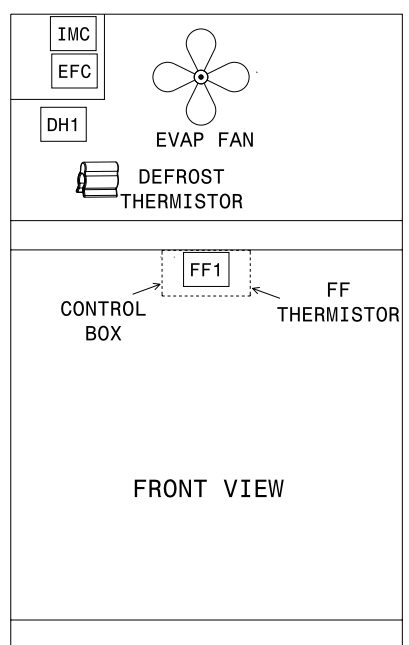

Wiring Diagram A15972201