

IKE9501BT

AEG

36" Built-In 5-Zone Induction Cooktop

FEATURES & BENEFITS

Induction Cooktop

Create tastier dishes in less time with an induction cooktop from AEG. Featuring superior temperature control, take your cooking to the next level with an electric induction cooktop. Unleash your culinary creativity and cook up a storm with AEG's induction Cooktops.

Blends Seamlessly Into Any Kitchen

The unique black surface, bevelled edges, and metal base align perfectly with every kitchen style. When the cooktop is switched off, the ceramic glass is completely black. While powered, the surface illuminates to reveal red LED backlit controls.

Bridge Zone

The Bridge function combines two cooking zones together to fit any large or long pan. Sharing the same temperature and time setting, the linked zones are ideal when you're cooking for dinner parties or bigger celebrations.

Touch & Slide Design Controls

The touch & slide design controls user interface allows for precise temperature control in an instant without having to toggle through the plus and minus buttons. Heat levels can be adjusted quickly, easily, and accurately.

Quicker heat for extra speed with PowerBoost

9 Power levels with a blast of fast. No more waiting around for pots to boil. The PowerBoost function gives you an instant burst of heat. PowerBoost is perfect for tasks that require you to boil a large pot of water quickly.

Pause Function

The pause function is useful if your cooking is interrupted. With the touch of a button all cooking zones will pause the cooking process, whilst another restarts it again with the same settings.



AVAILABLE COLOURS

 Black Ceramic Glass / Beveled Edges / Metal Frame

GENERAL PROPERTIES

Type	36" Induction Cooktop
Style	Built-In
Surface Colour	Black
Frame Colour	Metal Aluminum Frame (Four Sides)
Beveled Edge	Beveled Edges (Four Sides)

CONTROL FEATURES

Cooktop Control Type	Touch & Slide Design Controls
Control Location	Front - Center

COOKTOP FEATURES

Number of Zones	5 Cooking Zones
Lighted Icons	Red - LED Light
Bridge Zone Cooking Element	Left Side
Power Stage Setting	0-9 Power Levels
Power Boost Control	Yes
Timer Control	00 - 99 minutes
Pause Function	Yes
Keep Warm Control	Yes
Residual Heat Indicator	Yes
Automatic Safety Switch Off	Yes
Child Lock Function	Yes

ELEMENT PERFORMANCE

Zone / Power Boost Watts - Front Right	2000 W / 2600 W Power Boost
Zone / Power Boost Watts - Front Left	2000 W / 2600 W Power Boost
Zone / Power Boost Watts - Rear Right	1200 W / 1500 W Power Boost
Zone / Power Boost Watts - Rear Left	2000 W / 2600 W Power Boost
Zone / Power Boost Watts - Middle	2600 W / 3600 W Power Boost

ELEMENT SIZE

Diameter of Cooking Zones - Front Right	8 ¹ / ₂ " (216mm)
Diameter of Cooking Zones - Front Left	8 ¹ / ₂ " x 8 ¹ / ₂ " (216mm x 216mm)
Diameter of Cooking Zones - Rear Right	6" (152mm)
Diameter of Cooking Zones - Rear Left	8 ¹ / ₂ " x 8 ¹ / ₂ " (216mm x 216mm)
Diameter of Cooking Zones - Middle	11" (279mm)

TECHNICAL DETAILS

Total Connected Load	9600 W
Amperage (AMP)	50 AMP
Power Range / Rated Voltage	AC 208V ~ 60Hz ~ 8.3kW or AC 240V ~ 60Hz ~ 9.6kW
Power Cord Length	51" (1300mm)

DIMENSIONS

Product Dimensions (In / mm) (W / H / D)	35 ⁷ / ₁₆ " / 3 ⁹ / ₁₆ " / 20 ¹ / ₂ " (900mm / 91mm / 520mm)
Cut-Out Dimensions (In / mm) (W / H / D)	34 ⁵ / ₈ " / min. 5 ¹ / ₁₆ " / 19 ⁵ / ₁₆ " (880mm / min. 129mm / 490mm)

WARRANTY

Parts & Labor	2 Years
---------------	---------

Installation Details

PRODUCT DIMENSIONS

In (W / H / D)	35 ⁷ / ₁₆ " / 3 ⁹ / ₁₆ " / 20 ¹ / ₂ "
mm (W / H / D)	900mm / 91mm / 520mm

CUT-OUT DIMENSIONS

In (W / H / D)	34 ⁵ / ₈ " / min. 5 ¹ / ₁₆ " / 19 ⁵ / ₁₆ "
mm (W / H / D)	880mm / min. 129mm / 490mm

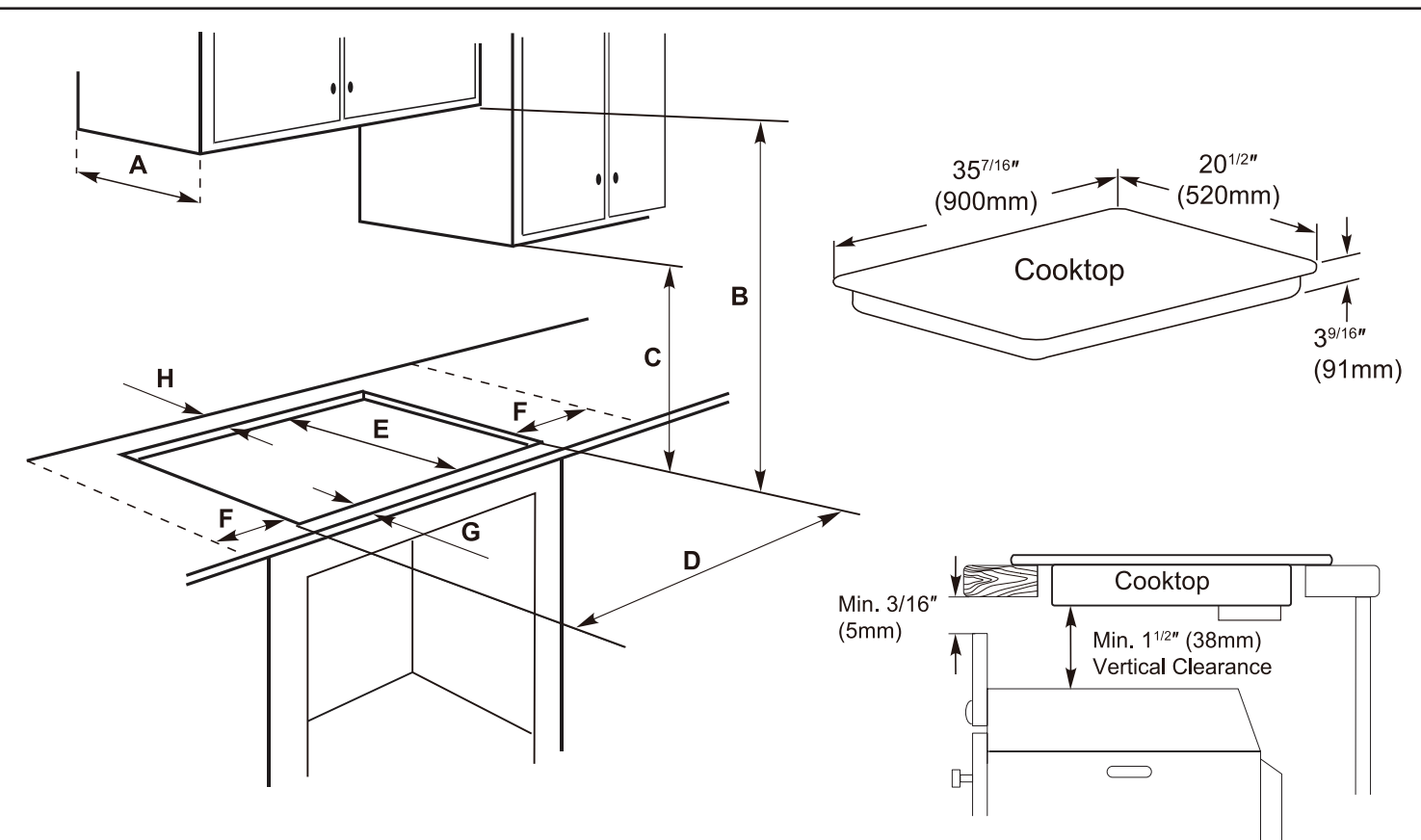

A	MAX. Depth of unprotected overhead cabinets.	13" (330mm)
B	MIN. Clearance from countertop to unprotected overhead surface.	30" (762mm)
C	MIN. Height from countertop to nearest cabinet on either side of unit.	18" (458mm)
D	Width of Cutout.	34 ⁵ / ₈ " (880mm)
E	Depth of Cutout.	19 ⁵ / ₁₆ " (490mm)
F	MIN. Clearance from cutout to left or right side of walls.	1 ³ / ₄ " (44mm)
G	MIN. From front edge of cutout and front edge of cooktop.	2 ³ / ₄ " (70mm)
H	MIN. Between cutout and the wall behind the cooktop.	2" (50mm)

INSTALLATION INSTRUCTIONS FOR BUILT-IN OVEN

- Ensure a minimum clearance of 20 mm (13/16") between the bottom of the cooktop and the oven. This space is essential to facilitate proper airflow .
- There must be a minimum gap of 5 mm (3/16") between the countertop and the door panel of the built-in oven or drawer. This clearance is crucial for optimal operation.
- Please be aware that inadequate airflow can significantly reduce the lifespan of the appliance.

Refer to user manual/installation instructions for further details

Other Product Downloads Available at aeg-appliances.ca

AEG

WARRANTY INFORMATION

Each appliance is covered by a comprehensive 2-year parts and labour warranty.
Refer to product warranty policy for complete terms and conditions.

FOR PARTS & SERVICE

Euro-Parts & Service

39822 Belgrave Road, Belgrave, ON. N0G 1E0 1-800-561-4614
www.euro-parts.ca • parts@euro-parts.ca • service@euro-parts.ca

AEG appliances are imported and distributed in North America by Euro-Line Appliances Inc. For more information, please visit one of our showrooms or www.ela.ca

EURO-LINE APPLIANCES INC.

871 Cranberry Court
Oakville, ON L6L 6J7
Tell: 905.829.3980
Toll-Free: 1-800.421.6332
Email: info@ela.ca

EURO-LINE APPLIANCES INC.

101-1014 Homer Street
Vancouver, BC V6B 2W9
604.235.3980
1-855.352.9378
infowest@ela.ca