

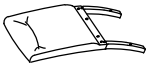







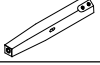

ASSEMBLY INSTRUCTIONS
INSTRUCCIONES

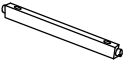
2225S CHAIR
2225S SILLA

No.	DESCRIPTION	Q'TY
A	CHAIR BACK 	1pc/pieza
B	SEAT FRAME & CUSHION 	1pc/pieza
C	LEFT LEG 	1pc/pieza
D	RIGHT LEG 	1pc/pieza
E	LEFT SIDE STRETCHER 	1pc/pieza
F	RIGHT SIDE STRETCHER 	1pc/pieza

No.	DESCRIPTION	Q'TY
①	BOLT  $\Phi 5/16'' \times 18'' \times 1-1/2''$ (Chair Back Center)	2pcs/piezas
②	BOLT  $\Phi 5/16'' \times 18'' \times 2-1/4''$ (Front Leg)	4pcs/piezas
③	BOLT  $\Phi 5/16'' \times 18'' \times 3-1/4''$ (Chair Back Leg Corner)	4pcs/piezas
④	ALLEN KEY  M5*2-1/4"L	1pc/pieza
⑤	SCREW  M4*1-1/2"	4pcs/piezas

ASSEMBLY TOOL
NOT INCLUDED

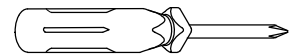

Step 1 / paso 1

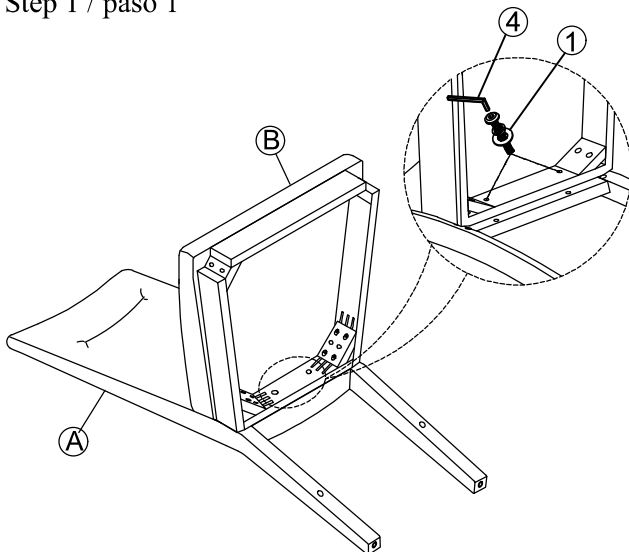

Step 2 / paso 2

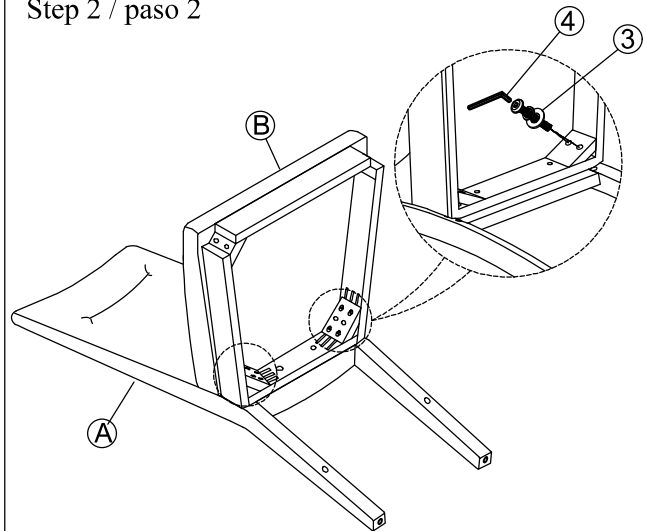

Step 3 / paso 3

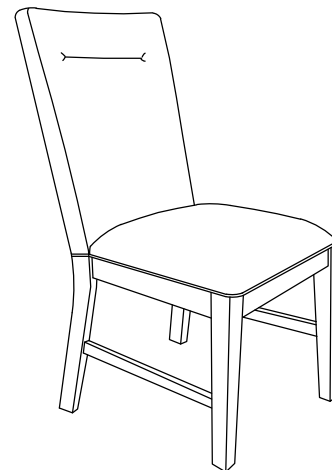
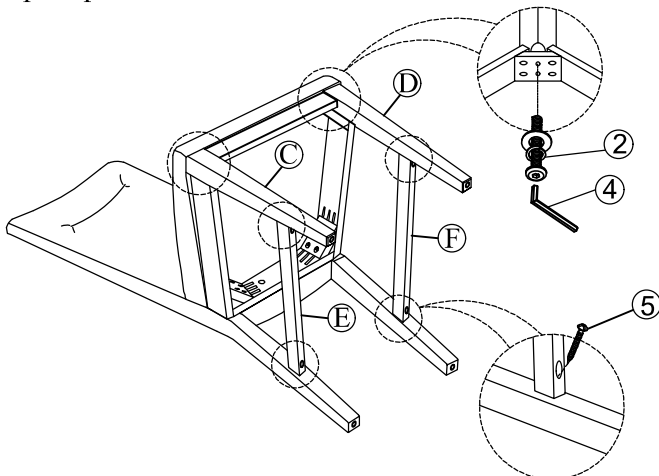

DO NOT TIGHTEN SCREWS UNTIL COMPLETELY ASSEMBLED !
NO APRETAR LOS TORNILLOS HASTA ARMAR COMPLETAMENTE