



BRAMBLE

PRODUCT TEARSHEET



Seraphine Cane Mirror

Shown in: **TRW**

SKU: **28962**

Size: **32W x 1D x 44H in**



Overview

Seraphine Cane Mirror

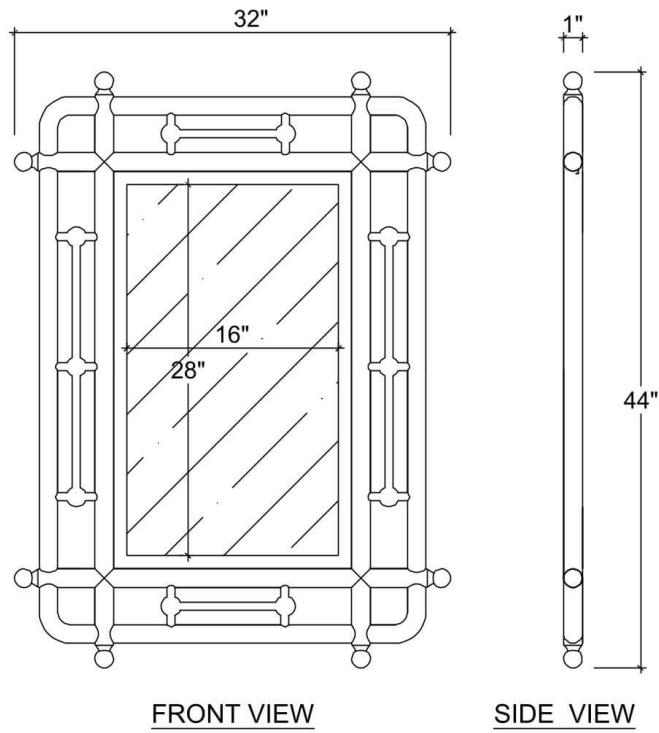

Visual Highlights



Technical Specification

Dimensions	32W x 1D x 44H in	CBM	0.085184
Number of Packages	1	Cubic Feet	3.01 ft³
Package 1 Dimensions	34.6 x 3.1 x 47.6 in	Package 1 Weight	28.66 lbs
Package Weight Total	28.66 lbs	Net Weight	23.15 lbs

New

<https://www.brambleco.com/28962>
