

GL-IPAC-SW8

Crestron Green Light® Integrated Switching System

1 Overview

The GL-IPAC-SW8 switching panel provides internal controls for 8 circuits of switched load and is expandable to support up to 64 circuits of switched load by adding external panels and switching modules. It features local inputs for sensors and keypads, along with an LCD user interface where installers or users can set up the system without having to connect to a computer.

The GL-IPAC-SW8 is perfect for smaller-sized installations, such as retail stores, small office spaces, parking garages, and service stations, which typically require only on/off switching—eliminating the need for a larger, more expensive panel. In addition, the GL-IPAC-SW8 can be easily integrated with Crestron® automation solutions for centralized monitoring and remote control of multiple locations.

Out-of-the-Box Lighting Control

The GL-IPAC-SW8 comes preconfigured for use as the central control processor for a Crestron Green Light® Power Switching system. Right out of the box, the GL-IPAC-SW8 affords easy setup and programming for a complete switching system consisting of up to 64 switched loads, 16 local and two remote keypads, 24 occupancy and photo sensors, and 100 time clock events.

Keypads with as many as 12 buttons each can be programmed easily to control lighting loads and other functions. Lights can be programmed to turn on and off automatically using the built-in astronomical time clock. Lighting events may be programmed to occur at specific times or at an offset from sunrise or sunset. Occupancy sensors and photo sensors may also be implemented to enable automatic on/off lighting control based on room occupancy and ambient light levels.

Save Energy

Built-in support for occupancy and photo sensors helps to strike a perfect balance between daylight harvesting and comfort, reducing energy costs. Automatically turn off lights in unoccupied areas to allow natural light level in the space to light the area. Crestron GLS sensors can be placed strategically in each space to maximize the benefits of energy management.

Easy Deployment

Packaged in one metal enclosure, the GL-IPAC-SW8 can be deployed in small spaces, including plenum ceilings. The surface-mount GL-IPAC-SW8 can be affixed to a wall or ceiling rafter, cleanly out of sight. Standard wire-entry knockouts are provided.

- 8 internal circuits for switched loads
- Expandable to control up to 64 circuits of switched load
- Supports 100 to 277 volt applications
- 16 amp load rating per channel
- Built-in astronomical time clock
- Positive air gap at each output
- Phase-independent channels
- Local controls for setup, testing, and verification
- Local and remote override capability
- Non-volatile power failure memory
- Easy access is facilitated from the hinged front cover

SPECIFICATION	DETAILS
Load Ratings	
Switched Channels	8 internal; Expandable up to 64 by adding external panels and modules
Per Channel	16 amps @ 120 to 277 Vac, 50/60 Hz
Switched Load Types	Fluorescent ballast, incandescent, magnetic low-voltage, electronic low-voltage, neon/cold cathode, high-intensity discharge, LED, motor
Relay Lifetime	
Resistive rating	100,000 on/off operations
General rating	50,000 on/off operations, 16 A @ 120/277 Vac
Power Requirements	
Main Power	100-277 Vac, 50/60 Hz, via channel 1 (LINE 1, NEUT)
Available Cresnet Power	15 watts at 24 Vdc
Environmental	
Temperature	32° to 104° F (0° to 40° C)
Humidity	10% to 90% RH (non-condensing)
Dimensions	
Height	12.13 in (308 mm)
Width	14.13 in (359 mm)
Depth	4.06 in (104 mm)

SPECIFICATION	DETAILS
Contact Closures	(1) 9-pin 3.5 mm terminal block comprising (8) contact closure inputs and (1) ground port
Sensor	(2) 6-pin 3.5 mm terminal blocks comprising (8) sensor inputs – (4) for occupancy and (4) for photocell, (2) 24 Vdc, and (2) ground ports (provides sensors with power – power is shared with Cresnet® port)
Cresnet Power	15 watts @ 24 Vdc (shared power for Cresnet devices, keypads, and sensors)
Switch Ratings	8 switched channels; 16 amps @ 120 to 277 Vac, 50/60 Hz per channel; Fluorescent ballast, incandescent, magnetic low voltage, electronic low voltage, neon/cold cathode, high-intensity discharge, LED, motor
Number of Devices	Maximum 64 switched loads, 16 keypads, 24 occupancy sensors, 24 photo sensors, and 100 time clock events; Supports up to 8 internally switched loads; Supports up to 56 externally switched loads

GL-IPAC-SW8

Crestron Green Light® Integrated Switching System

2 Wiring Diagram

The following illustration is a detailed connection overview of a GL-IPAC-SW8 system.

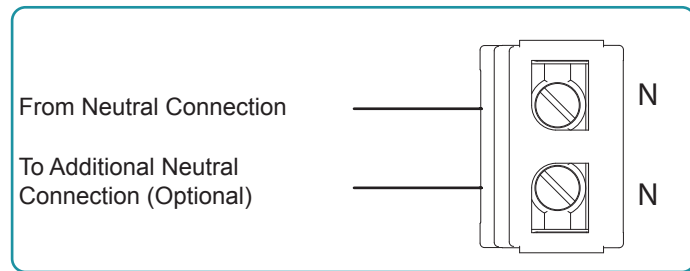

CKT 1 is used to power the GL-IPAC-SW8. Line power can be daisy chained from **LN1** to **LN2** to **LN3** and so on. **LN1**, **LN2** through **LN8** can also be powered by individual circuits. Use 14 - 10 AWG wiring.

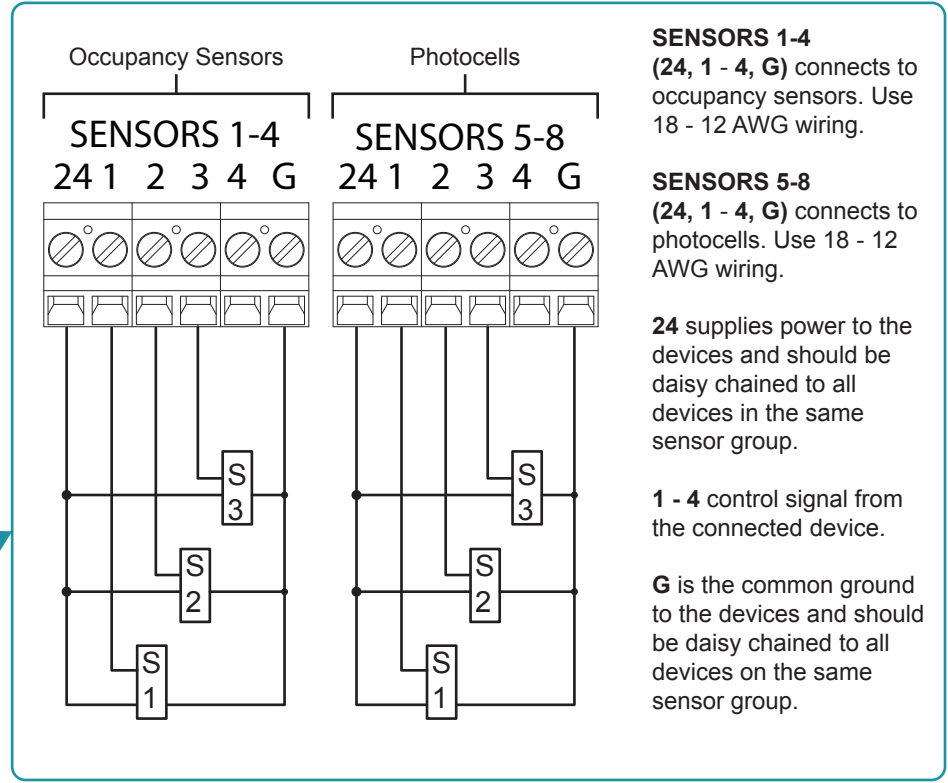
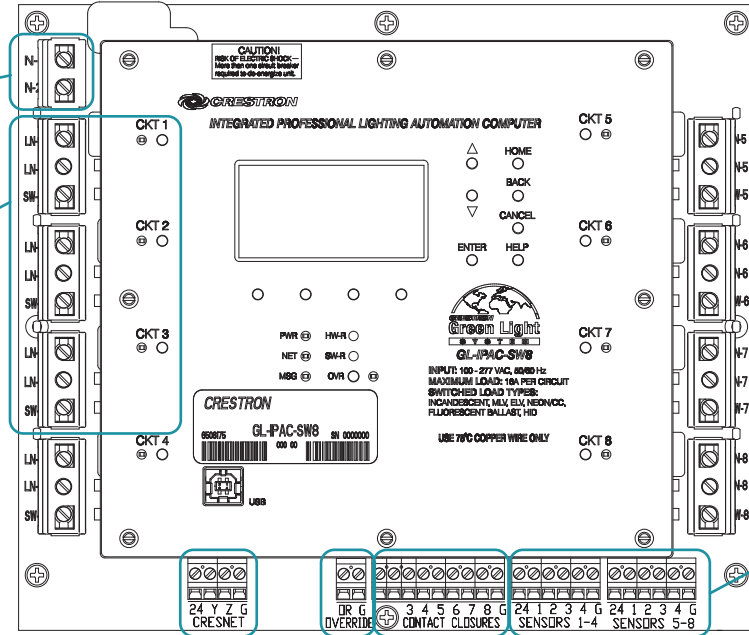
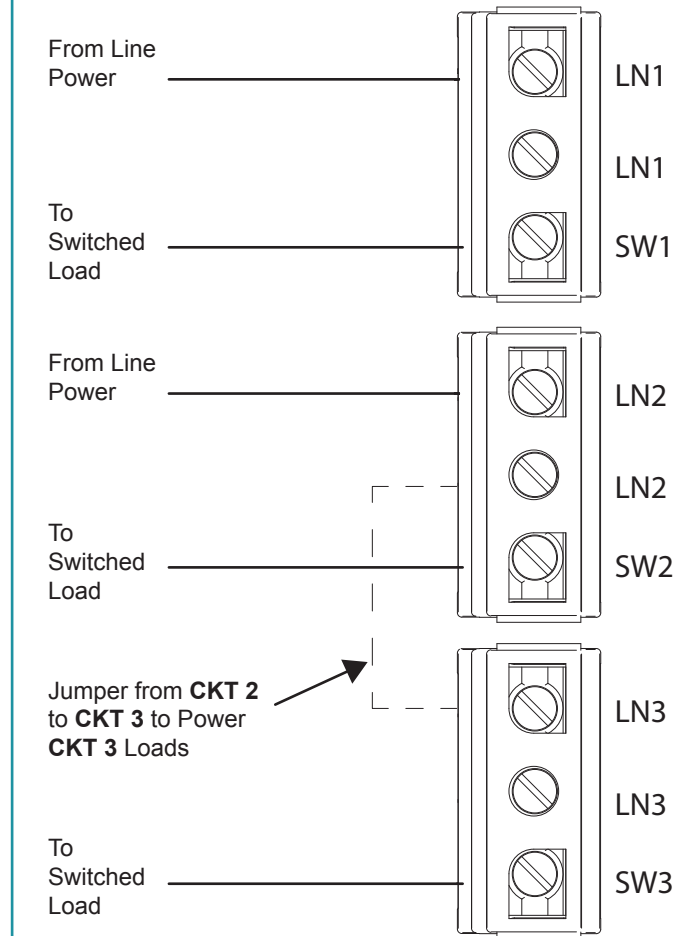

SENSORS 1-4 (24, 1 - 4, G) connects to occupancy sensors. Use 18 - 12 AWG wiring.

SENSORS 5-8 (24, 1 - 4, G) connects to photocells. Use 18 - 12 AWG wiring.

24 supplies power to the devices and should be daisy chained to all devices in the same sensor group.

1 - 4 control signal from the connected device.

G is the common ground to the devices and should be daisy chained to all devices on the same sensor group.

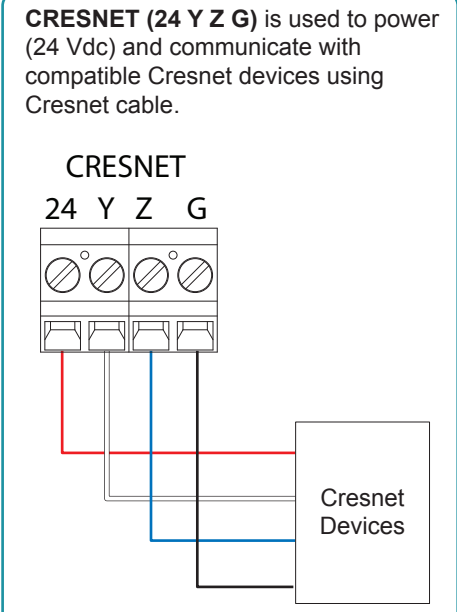

CRESNET (24 Y Z G) is used to power (24 Vdc) and communicate with compatible Cresnet devices using Cresnet cable.

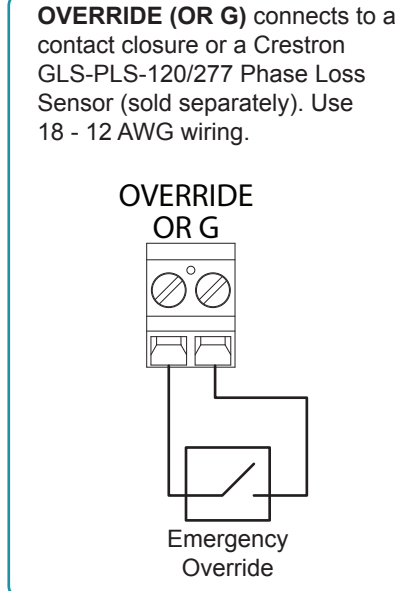

VERRIDE (OR G) connects to a contact closure or a Crestron GLS-PLS-120/277 Phase Loss Sensor (sold separately). Use 18 - 12 AWG wiring.

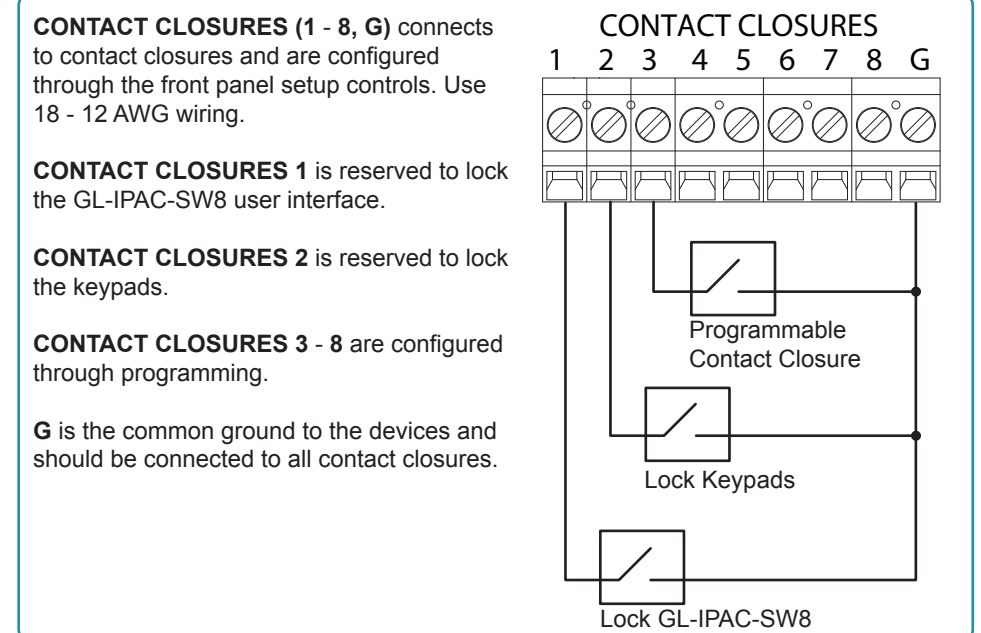

CONTACT CLOSURES (1 - 8, G) connects to contact closures and are configured through the front panel setup controls. Use 18 - 12 AWG wiring.

CONTACT CLOSURES 1 is reserved to lock the GL-IPAC-SW8 user interface.

CONTACT CLOSURES 2 is reserved to lock the keypads.

CONTACT CLOSURES 3 - 8 are configured through programming.

G is the common ground to the devices and should be connected to all contact closures.

(Continued on following page)

2 Wiring Diagram (Continued)

Occupancy Sensor Wired to SENSORS 1-4 Port

Occupancy sensors can only be wired to the **SENSORS 1-4** port.

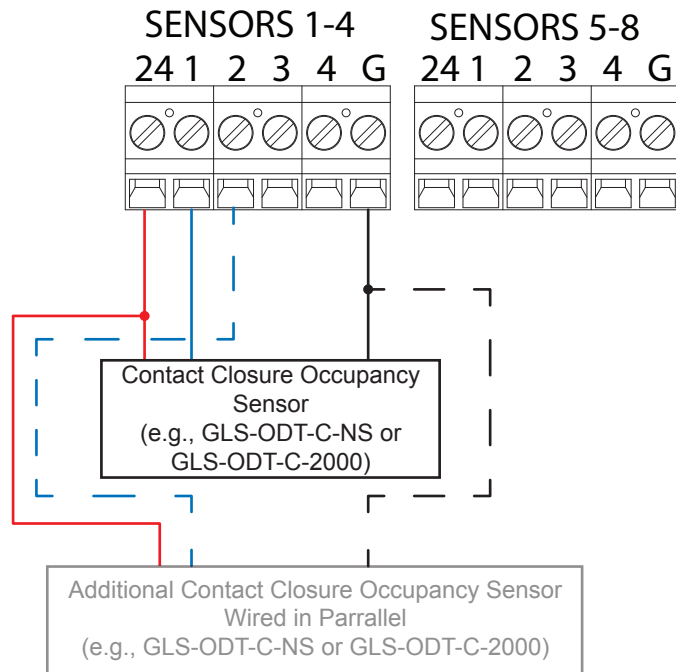

Cresnet Occupancy Sensor and Photocell Wired Using Cresnet

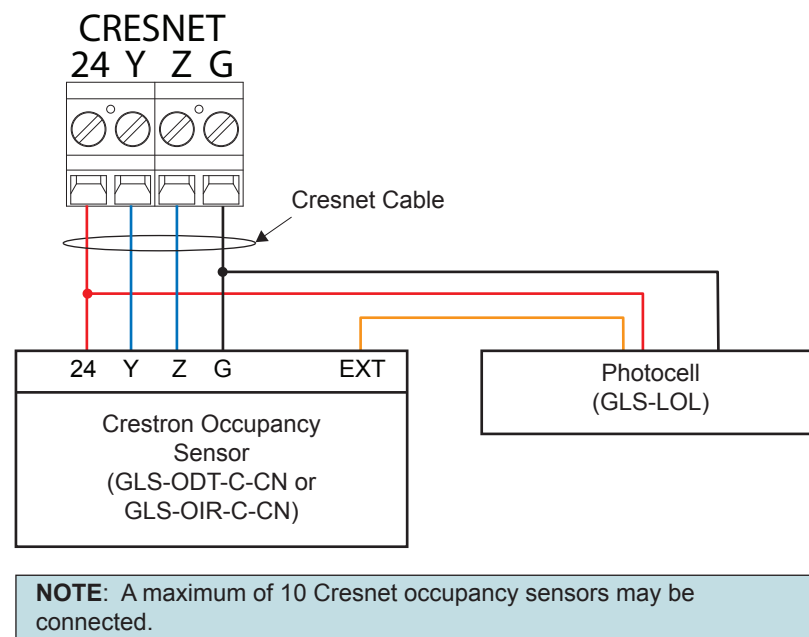

Occupancy Sensor Wired to Cresnet Port Using a GLS-SIM

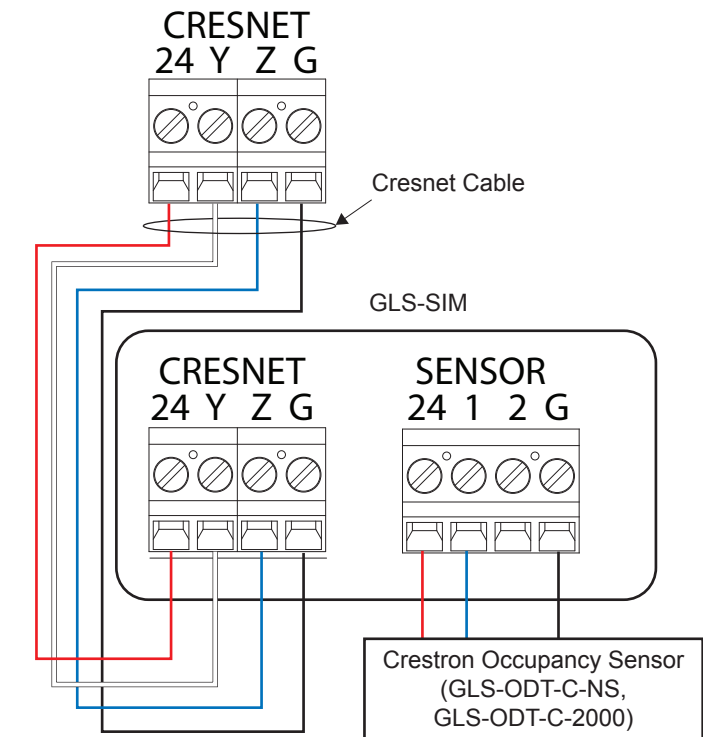

INPUT CHANNEL	DIP SWITCH	SETTING
1	1	On
	2	On
2	3	-
	4	-

Use the dials to set the ID of the GLS-SIM to C0 - C9 to match the ID defined in the program.

NOTE: A maximum of 10 GLS-SIMs may be connected.

(Continued on following page)

GL-IPAC-SW8

Crestron Green Light® Integrated Switching System

2 Wiring Diagram (Continued)

Photocell Wired to SENSORS 5-8 Port

Photocells can only be wired to the right **SENSORS 5-8** port.

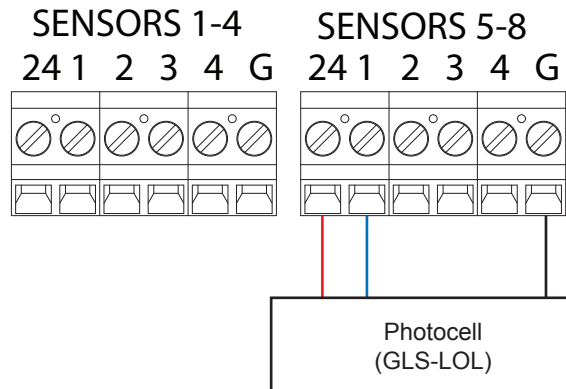

Using GLS-PLS-120/277 to Provide Override Control

A GLS-PLS-120/277 connects to 3-phase inputs and neutral power connections. The **OUTPUT 1** or **OUTPUT 2** port connects to the **VERRIDE OR G** port on the GL-IPAC-SW8.

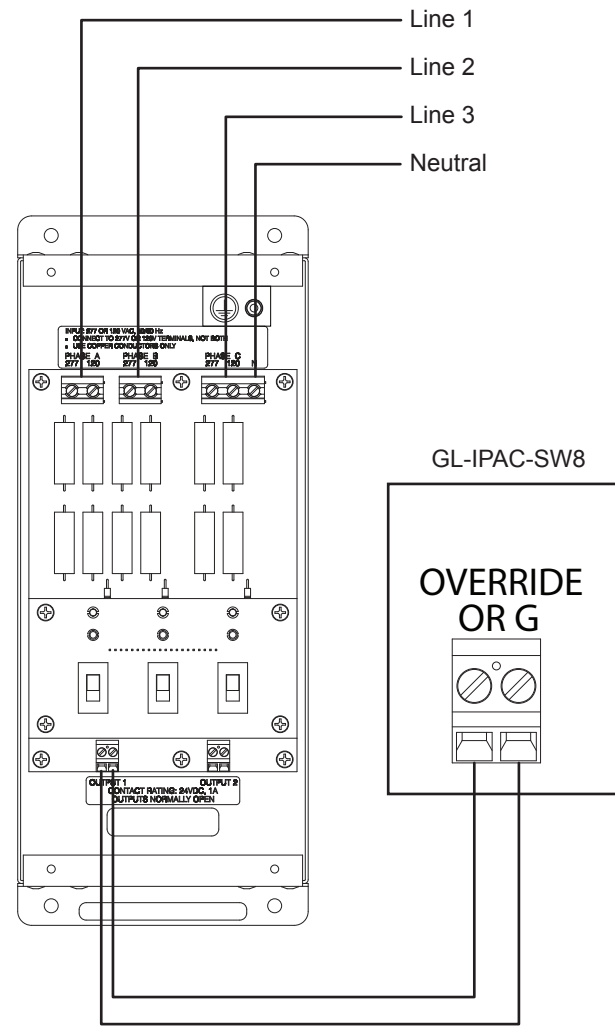

Adding an Additional Lighting Panel

Adding an additional lighting panel to the GL-IPAC-SW8 is accomplished by connecting the two panels together via the Cresnet port.

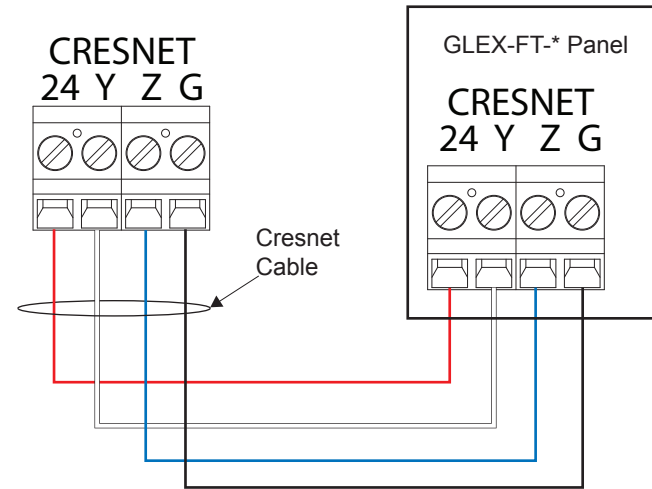

Photocell Wired Using Cresnet to GLS-SIM

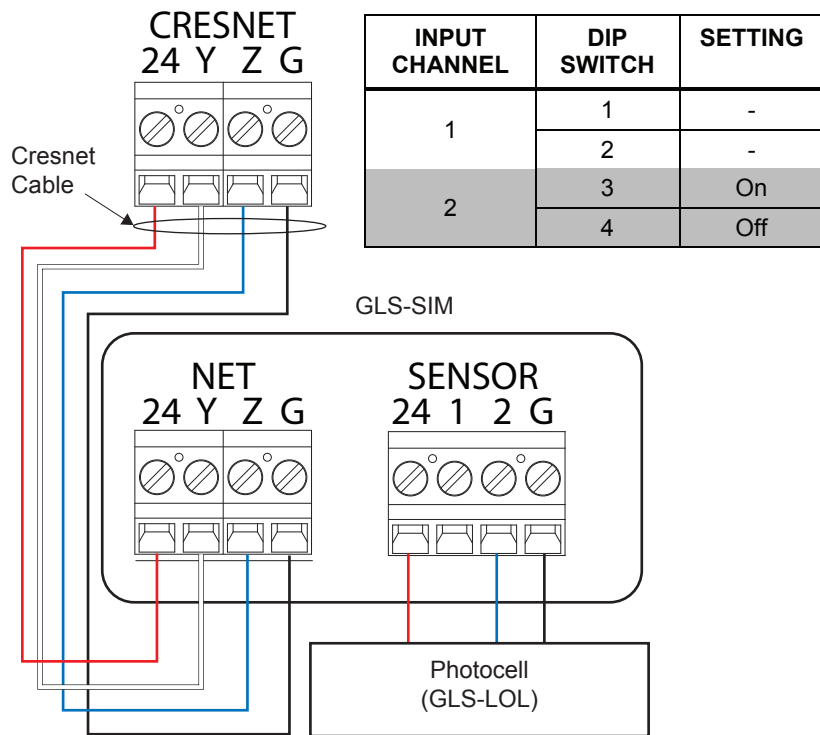

Use the dials to set the ID of the GLS-SIM to C0 - C9 to match the ID defined in the program.

NOTE: A maximum of 10 GLS-SIMs may be connected.

Adding Additional Power

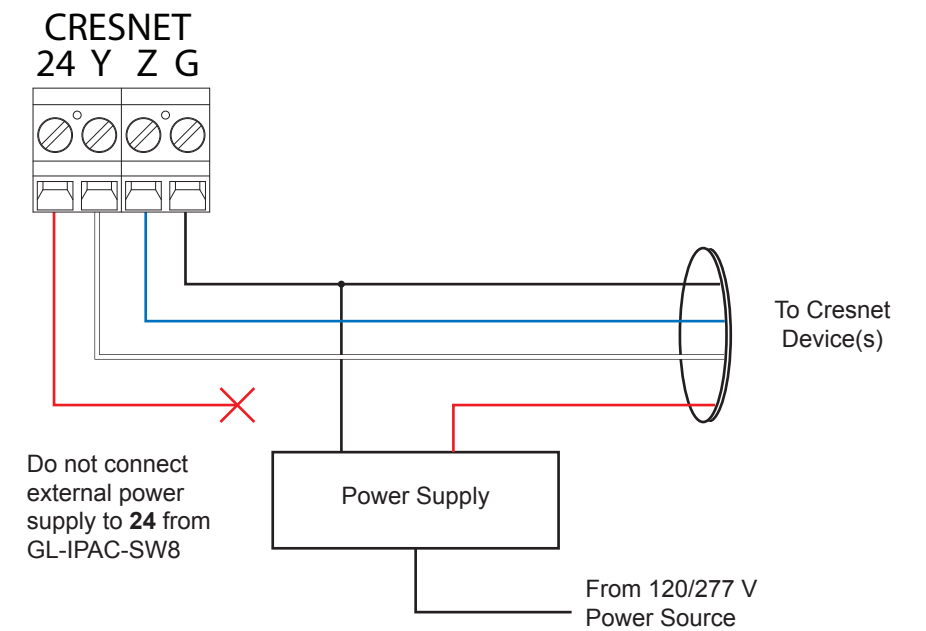

3 Front Panel Controls

The following is a detailed overview of the front panel controls on the GL-IPAC-SW8 system.

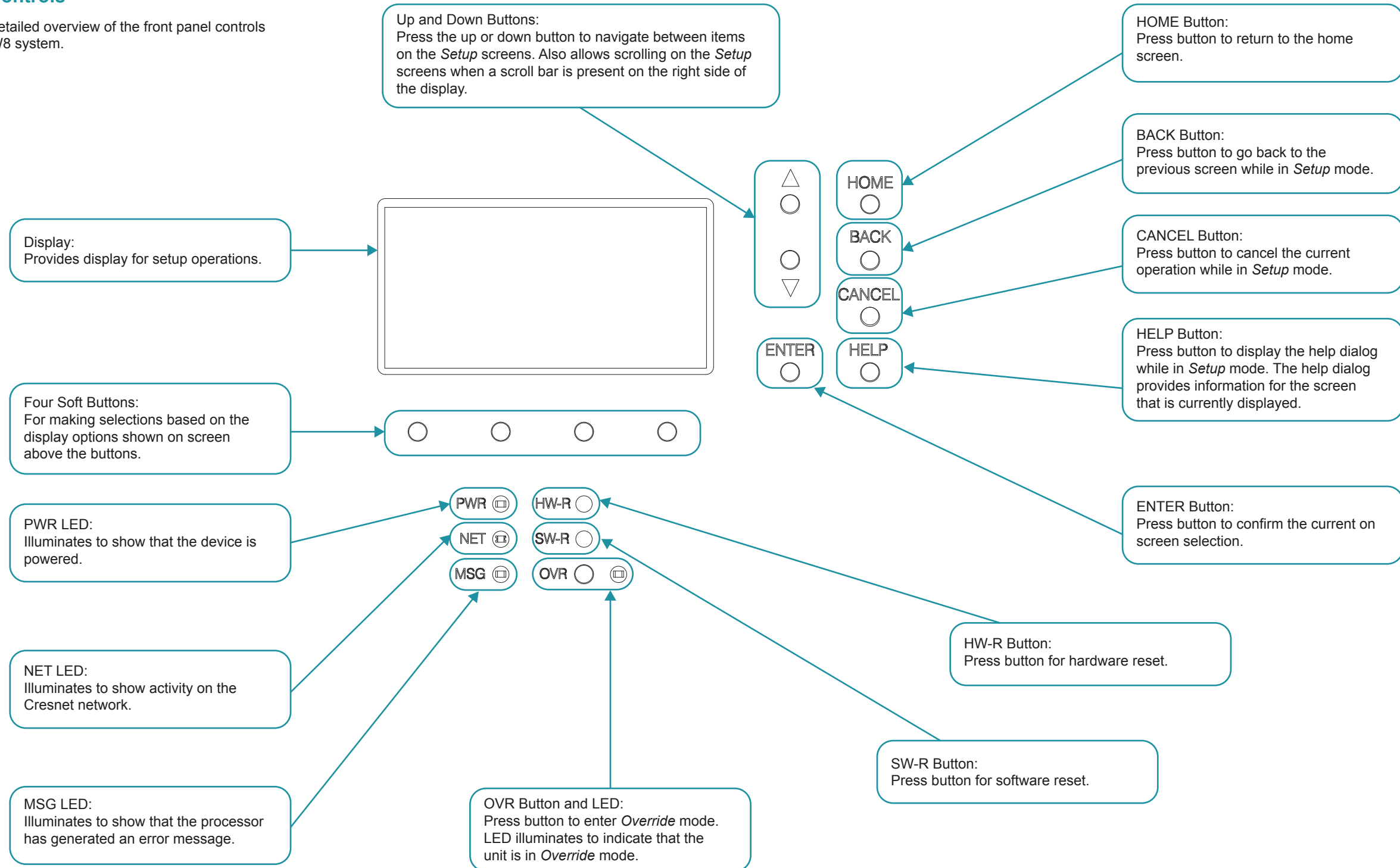

4 Setup

Follow the procedures below to set up the GL-IPAC-SW8.

Use the front panel controls and display to configure the GL-IPAC-SW8. The following controls are used to navigate the front panel display: up arrow, down arrow, **ENTER**, **HOME**, **BACK**, **CANCEL**, and **HELP**. There are four soft buttons which perform the functions listed above them on the front panel display screen.

From the home screen on the front panel display, press **Setup** to access the full list of options for configuring the GL-IPAC-SW8. Press the **HELP** button while on any setup screen to display additional setup information.

If timeclock events need to be changed after the GL-IPAC-SW8 is fully configured, press **TmClk** to add, edit, or remove timeclock events. The **TmClk** button enters the timeclock procedure starting on page 11.

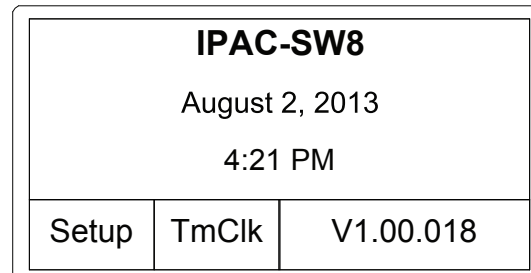

"Setup" Menu

After pressing **Setup**, a list of 10 configuration options appears:

- *Project Settings* sets the geographical location of the GL-IPAC-SW8 installation as well as the time, date, and daylight savings settings.
- *Panels* configures the additional lighting panels controlled by the GL-IPAC-SW8.
- *Occupancy Sensors* configures the occupancy sensors attached to the GL-IPAC-SW8.
- *Photo Sensors* configures the photo sensors attached to the GL-IPAC-SW8.
- *Keypads* configures all keypads in the system.
- *Remote Keypads* configures keypads connected to external systems via IP.
- *Contact Closures* triggers specific actions using two pre-defined contact closure inputs and six custom contact closure inputs.
- *Timeclock* configures the timeclock.
- *Ethernet Settings* configures the Ethernet settings.
- *About* displays the GL-IPAC-SW8 information.

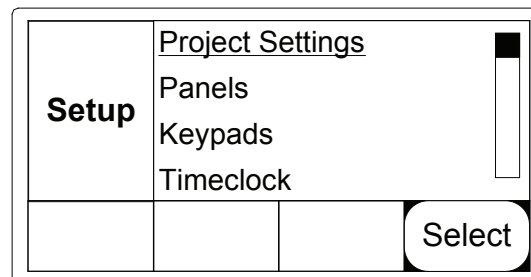

Project Settings

Project Settings: "Select State" Screen

Select *Project Settings* from the "Setup" menu to configure basic GL-IPAC-SW8 settings.

Use the up and down buttons to highlight the nearest city then press **Next** to advance to the "System Setup" screen.

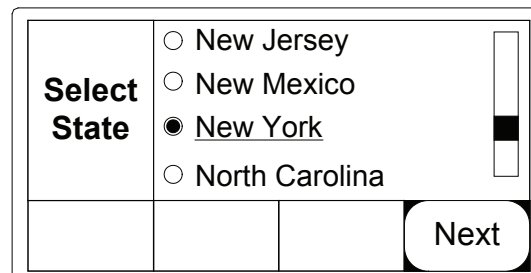

The following screens allow configuration of the date, time, and daylight savings settings.

Press **Next** from the "System Setup" screen to advance to the "Set Current Date" screen.

On the "Set Current Date" screen use the up and down buttons to change the month, date, and year. Press **ENTER** to move between the date and year. Press **Next** to advance to the "Set Current Time" screen.

Press **Edit** on the "Set Current Time" screen to change the time. Use the up and down buttons to change the values and **ENTER** to move between the hour, minute, second, and AM/PM. Press **Set** to save the values.

Press **Next** to advance to the "Daylight Savings Time" screen. Using the up and down buttons select *Off* or *Auto*. *Off* turns daylight savings time off and *Auto* updates the time based on daylight savings time for the region.

Press **ENTER** to make the selection and **Exit** to save the settings and return to the "Setup" menu.

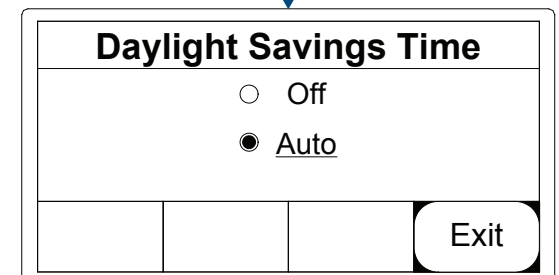
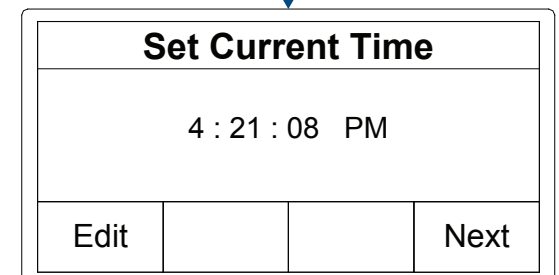
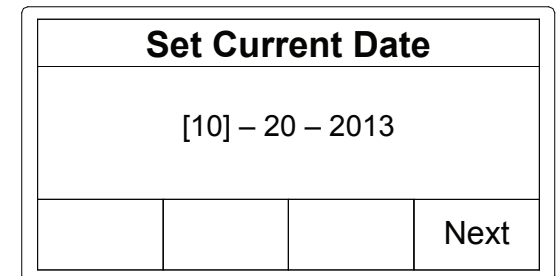

Panels

Panels: "Load Count" Screen

Select *Panels* from the "Setup" menu to modify external panel lighting loads. The "Load Count" screen identifies internal and external loads on the GL-IPAC-SW8. The GL-IPAC-SW8 supplies eight circuits to switch loads.

To change the number external loads, highlight *EXT: --- --* and press **Edit**. Use the up and down arrows to change the number of external loads then press **ENTER**.

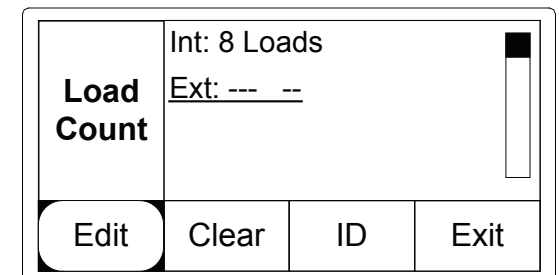

(Continued on following page)

4 Setup: Panels (Continued)

Panels: Set External Loads' IDs

Each load in an external panel is controlled by a lighting module installed in the external panel. To properly control the external loads in a system, the connected modules must be identified to the GL-IPAC-SW8.

Set the ID of an external module according to the list on the right side of the screen. Press **OK** to exit the screen.

NOTE: ERR indicates that a module ID cannot be found.

Set Module ID's in PNL-1 to these values:	11	OK
	12	OK
	13	ERR
	14	---
OK		

Occupancy Sensors

Occupancy Sensors: "Occ Sensr List" Screen

To configure occupancy sensors for the GL-IPAC-SW8, select *Occupancy Sensors* from the "Setup" menu. The "Occ Sensr List" screen provides a list of all connected occupancy sensors. There can be a total of 24 occupancy sensors connected to the GL-IPAC-SW8. There are three types of occupancy sensors:

- 4 internal, non-system sensors (Sensor 1 to 4)
- 10 external Cresnet sensors (Sensors B0.1 to B9.1)
- 10 external, non-system sensors - Connected to Cresnet via GLS-SIM (Sensors C0.1 to C9.1)

Press **Exit** to save the settings and return to the "Setup" menu.

Occ Sensr List	Sensor 1		
	Sensor 2		
	Sensor 3		
	Sensor 4		
Loads		Test	Exit

Internally Connected Occupancy Sensors

Occupancy Sensors: "Internal Sensor Test" Screen

From the "Occ Sensr List" screen highlight an internal sensor using the up and down arrows and press **Test** to enter the "Internal Sensor Test" screen.

Press **Type** to define one of the available states:

- "Active Hi" (Default)
- "Active Lo"
- "Normally Open (N/O)"
- "Normally Closed (N/C)"

Status shows the current sensor state (*Active* or *Inactive*) based on the chosen type.

Press **OK** to save the setting and return to the "Occ Sensor List" screen.

Internal Sensor Test	
IN 1: Type=Active Hi	
Status=Inactive	
Type	OK

Cresnet Connected Occupancy Sensors

Occupancy Sensors: "Find Sensor B1.1" Screen

NOTE: Internal sensors, wired directly to the GL-IPAC-SW8, do not need to be discovered.

External Cresnet sensors range from B0.1 through B9.1. Highlight the external sensor from the "Occ Sensr List" screen and then press **Find** to set IDs for Cresnet occupancy sensors. Three options to find the sensors are presented:

- *Set ID using IR Remote* allows sensor to be found using an IR remote. This requires a direct view of the sensor, but does not require physical access to the sensor.
- *Find by pressing test button* allows sensor to be found by pressing the button on the inside of the sensor. This requires the sensor to be physically accessible, which may require a ladder or step stool.
- *Find by serial number* allows the sensor to be found by entering the serial number of the sensor. The sensors serial number must be recorded prior to installation.

Use the up and down arrows to select the desired option and press **OK**.

Find Sensor B1.1	
Set ID using IR Remote	
Find by pressing test button	
Find by serial number	
	OK

Occupancy Sensors: "Sensor B1 Test" Screen

After a Cresnet occupancy sensor is found, press **Test** to confirm functionality.

State describes the current state of the sensor: occupied or vacant.

Raw shows what the sensor is currently detecting; every time movement is sensed the radio button fills in.

Timeout is the time the sensor must detect continuous vacancy before going to its vacant state. Timeout can be local, 30 seconds, 2 minutes, 5 minutes, 10 minutes, 15 minutes, or 30 minutes. The local setting uses the timeout set via the IR remote. Any programming overrides the occupancy sensors settings.

Press **TmOut** to change the time before the occupancy sensor times out.

Press **OK** to save settings.

Sensor B1 Test	
B1.1: State = Vacant	
B1.1: Raw O	
B1.1: Timeout - 30s	
TmOut	OK

GLS-SIM Connected Occupancy Sensors

Occupancy Sensors: "Find Sensor C0.1" Screen

External occupancy sensors connected to a GLS-SIM range from C0.1 through C9.1. Highlight the external sensor from the "Occ Sensr List" screen and then press **Find**. Set the ID on the GLS-SIM to match the settings displayed on the GL-IPAC-SW8.

Press **OK** to return to the "Occ Sensr List" screen.

Find Sensor C0.1	
Ensure that the NET ID has been set to CO, and that the NET and PWR LEDs are lit.	
	OK

(Continued on following page)

4 Setup: Occupancy Sensors (Continued)

Occupancy Sensors: "Sensor C0.1 Test" Screen

From the "Occ Sensor List" screen, highlight an external sensor connected to a GLS-SIM using the up and down arrows and press **Test** to enter the test screen.

Set the type of sensor on the GLS-SIM using the DIP switches. Refer to the GLS-SIM Operations and Installation Guide (Doc. 6768) available at www.crestron.com/manuals.

Status shows the current sensor state based on the set type. Press **OK** to return to the "Occ Sensor List" screen.

Sensor C0.1 Test	
Set type on GLS-SIM	█
Status=Inactive	
	OK

On the "Sensor Load Assignment" screen loads *L1.1* through *L1.8* are displayed. For an external panel the loads are listed *L2.1* through *L2.56*. The first digit represents the panel and the second digit represents the load. Next to panel and load, in parenthesis, functions already assigned to that sensor display as single letters. A "p" designates photo sensor assignment. An "o" designates occupancy sensor assignment. The occupancy sensor that is assigned to the load is listed on the right side of the screen. If no sensor has been assigned "-" is displayed.

To assign an occupancy sensor to a load, select **Edit** then use the up and down buttons to select the occupancy sensor. Press **Set** to confirm the selection. Press **Mode** to assign an action to the load:

- *On/Off* turns the load on and off based upon occupancy or vacancy.
- *Off Only* turns the load off based upon vacancy.
- *Auto/Off* allows the sensor to detect occupancy and then checks the ambient light levels to determine if the lights should be turned on. When vacancy is detected, lights turn completely off.

The illustration shows two different sensors assigned to two different loads. They function as follows:

- Sensor 2 turns load 1 on panel 1 off.
- Sensor 3 turns load 2 on panel 1 on or off depending on occupancy or vacancy state.

Multi allows multiple occupancy sensors to be grouped together. This allows multiple occupancy sensors to monitor large areas and work together to ensure the area is occupied or vacant before taking action. When one occupancy sensor detects motion, the area is assumed to be occupied. All connected occupancy sensors in a group must go vacant for the vacancy action to trigger.

OK saves the assignments and returns to the "Setup" menu.

Sensor Load Assignment	
L 1.1 (p,o) = Sensor 2 (Off Only)	█
L 1.2 (p,o) = Sensor 3 (On/Off)	
L 1.3 (p) = - - -	
Multi	Mode Edit OK

From the "Sensor Load Assignment" Screen press **Multi** to enter to "Occ Multi" screen.

On the "Occ Multi" screen Groups 1 through 10 are displayed. The first digit in parenthesis indicates how many sensors are assigned to each group. If no sensor has been assigned to the group, "0" is displayed inside the parenthesis.

To assign an occupancy sensor to a group, use the up and down buttons to select the sensor group and then select **Edit**. Then use the up and down buttons to highlight the occupancy sensor and then **Enter** to select it. Press **Set** to add the sensor to the group. The number of sensors in the group is indicated within the parenthesis.

OK saves the assignments and returns to the "Sensor Load Assignment" menu.

Occ Multi	Group 1 (2)	█
	Group 2 (3)	
	Group 3 (4)	
	Group 4 (0)	
	Edit OK	

Photo Sensors

Photo Sensors: "Photocell List" Screen

Select *Photo Sensors* from the "Setup" menu to enter the "Photocell List" screen. The screen displays the available photo sensors. The GL-IPAC-SW8 has two types of sensors:

- 4 internal (Sensors 5 through 8)
- 10 external non-system sensors wired directly to a Cresnet occupancy sensor (Sensors B0.2 through B9.2)
- 10 external non-system sensors wired to a Cresnet GLS-SIM (Sensors C0.2 through C9.2)

Press **Loads** to assign loads to particular sensors.

Photo -cell List	Sensor 5	█
	Sensor 6	
	Sensor 7	
	Sensor 8	
Loads	Setup	Exit

Photo Sensors: "Select range (fc)" Screen

Highlight the desired sensor on the "Photocell List" screen using the up and down arrows and then press **Setup** to configure the sensor.

The screen provides three lighting levels in foot-candles (fc). For open loop sensors (GLS-LOL) select *3-300 (GLS-LOL)*, *30-3000 (GLS-LOL)*, or *60-6000 (GLS-LOL)* depending on the lighting level required to trigger an action. Settings on the "Select range (fc)" screen must match jumper settings on the GLS-LOL.

Other photo sensors should be assigned to *0-1000 (Other)*.

Press **Next** to advance to the "Ctrl Type" screen.

Int.5	<input type="radio"/> 3-300(GLS-LOL)	█
Select range (fc)	<input type="radio"/> 30-3000(GLS-LOL)	
	<input type="radio"/> 60-6000(GLS-LOL)	
	<input type="radio"/> 0-1000(Other)	
		Next

Photo Sensors: "Ctrl Type" Screen

The control type assigns what the sensor is going to do to the specific loads it is assigned to. There are three options: *On/Off*, *Hi/Lo/Off*, and *Hi/Med/Lo/Off*.

- *On/Off* determines when the photo sensor turns lights on after ambient light levels drop below the assigned threshold and when the photo sensors turn lights off after ambient light levels rise above the assigned threshold.
- *Hi/Lo/Off* allows the user to assign specific loads to the "Lo" and "Hi" settings. If ambient light levels exceed the upper threshold, all loads are turned off. When ambient light levels drop below the upper threshold, "Lo" loads are turned on. When the ambient light levels drop below the lower threshold, "Hi" loads are also turned on.
- *Hi/Med/Lo/Off* allows the user to assign specific loads to the "Lo" and "Med" settings. If ambient light levels rise above the upper threshold, all loads are turned off. If ambient light levels drop below the upper threshold, "Lo" loads are turned on. If ambient light levels drop below the second threshold, "Med" loads are turned on and "Lo" loads are turned off. If ambient light levels drop below the last threshold, both "Lo" and "Med" loads are turned on to their high setting.

Highlight the desired option and press **Next** to adjust the threshold associated with the setting.

Int.6	<input type="radio"/> On/Off	█
Ctrl Type	<input checked="" type="radio"/> Hi/Lo/Off	
	<input type="radio"/> Hi/Med/Lo/Off	
		Next

(Continued on following page)

4 Setup: Photo Sensors (Continued)

Photo Sensors: "Photocell Setup" Screen – For on/off

The "Photocell Setup" screen allows adjustment of the lighting threshold settings. The bar graph is displayed that represents the settings. The dotted section in the bar graph represents the hysteresis buffer that prevents the lights from cycling when ambient light levels near the threshold.

A tick mark on the top of the bar graph shows the current ambient light level that is reported by the sensor.

The settings determine the functionality of the loads as described below. Refer to the illustration that follows for details.

- When light level is less than L1 both Lo and Hi lights are on.
- When light level is greater than L2, both Lo and Hi lights are off.
- When light level is between L1 and L2, Lo lights are on and Hi lights are off.

Press **L 1**, **L 2**, or **L 3** to switch between the available levels. Use the up and down buttons to change the threshold. Press **Band** to adjust the hysteresis buffer. Press **Done** to return to the "Photo Cell List" screen.

Photocell Setup Int.6

Current: 0
On: 93

L 1: 99
Off: 104

L 2
Band
Done

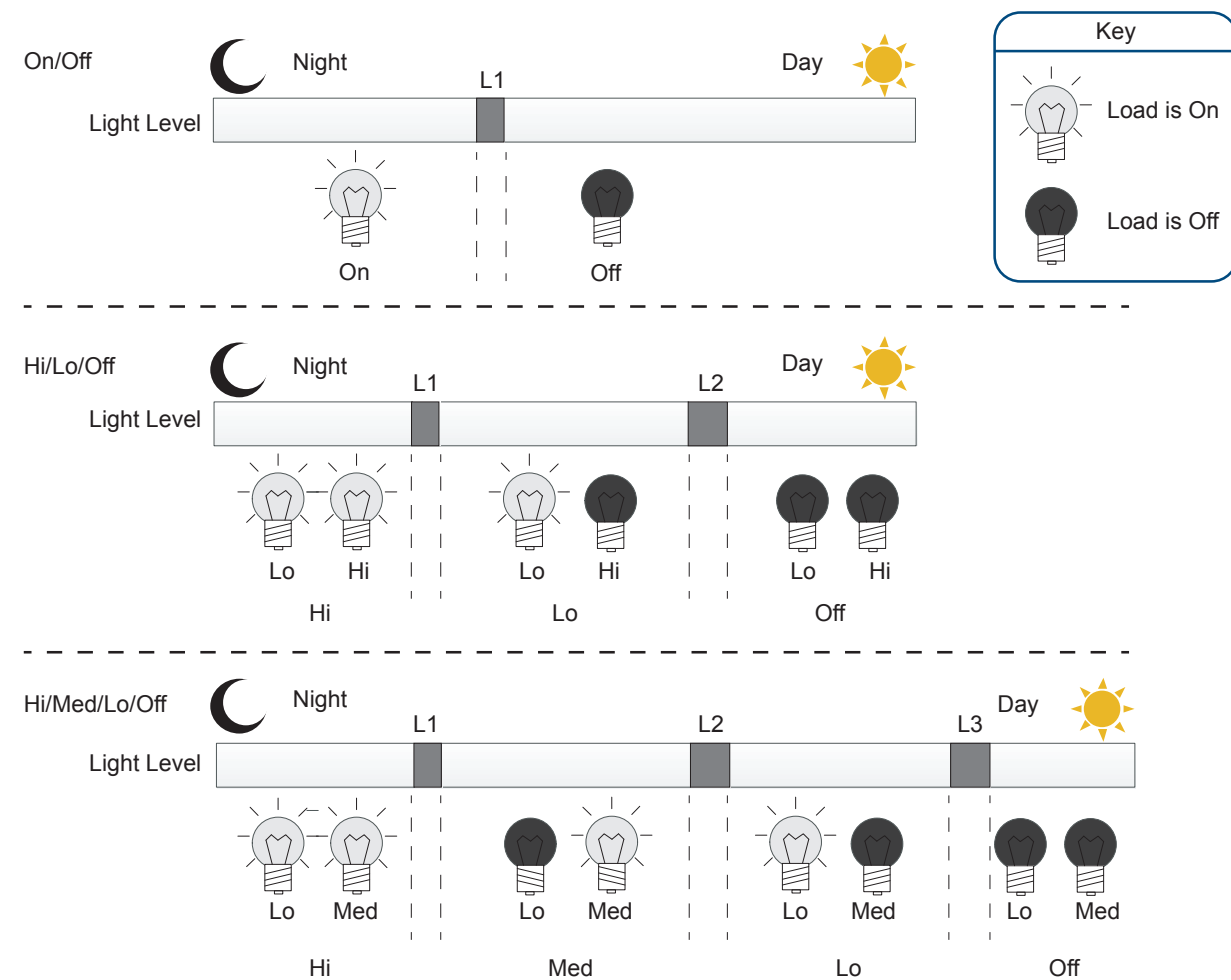

Photo Sensors: "Photocell Assignments" Screen

The "Photocell Assignments" screen assigns photo sensors to loads. Configure the photocells in the same manner as the occupancy sensors. Refer to "Occupancy Sensors" on page 7 for details.

Use the up and down buttons to highlight the desired load and press **MODE** to assign a photo sensor function to the load. Each function (*Hi*, *Med*, *Lo*, *Off*) operates the connected load according to the settings established on the "Photocell Setup" screen.

Press **OK** to save assignments.

Photocell Assignments

L 1.1 (p,o) = Sensor5 (Med)

L 1.2 (p,o) = Sensor6 (Hi)

L 1.3 (o) = - - -

Copy
Mode
Edit
OK

Keypads

Keypads: "Keypd List" Screen

After selecting *Keypads* from the "Setup" menu, the "Keypd List" screen appears. A total of 16 external keypads can be connected to the GL-IPAC-SW8. Press **Find** to begin the keypad search process. Then, find the keypad by pressing a button on the keypad or entering the keypad's serial number. Note that all keypads flash if opting to find a keypad by pressing one of its buttons. Once the button of a flashing keypad is pressed, the keypad is identified by the GL-IPAC-SW8 and assigned an ID number. *Online* means the GL-IPAC-SW8 found the keypad; *Not Found* means the GL-IPAC-SW8 cannot find the keypad.

Keypad functions can be assigned automatically or manually:

- **Press** assigns functions to pressed button automatically.
- **Edit** assigns functions manually.

After a keypad has been found and programmed the programming for the keypad may need to change. Use the up and down arrows to highlight one of the keypads that is marked "Online." When an "Online" keypad is selected, the **Find** button changes to the **ID** button. Press the **ID** button to locate the keypad—the keypad blinks until a button is pressed.

Keypd List

1: Not Found

2: Not Found

3: Not Found

4: Not Found

Press
Edit
Find
Exit

Keypd List

1: Online

2: Online

3: Online

4: Not Found

Press
Edit
ID
Exit

Keypads: Auto-Select

After pressing **Press**, *Auto Select* is initiated. Press a button on the keypad to program it. The GL-IPAC-SW8 directs the user to "Select Btn" screen.

Keypd List

1: Online

Auto Select:
Press a button
to program

ESC
Edit
Find
Exit

(Continued on following page)

4 Setup: Keypads (Continued)

Keypads: "Select Btn" Screen
To manually program or edit a button's function, select the button on the "Select Btn" screen.
Press **Edit** to display functions.
Copy duplicates button functions and **Paste** adds the functions to another button.
OK saves the button functions.

KP-1	Button 1		
Select Btn	Button 2		
	Button 3		
	Button 4		
Edit	Copy	Paste	OK

Keypads: "Select Btn Type" Screen
Assign a button function by selecting any of the following options: *On, Off, Toggle, Custom, Enter Override, Exit Override, Enter/Exit Override, Enable Timeclock, Disable Timeclock, and Enable/Disable Timeclock.*
Select **Next** to assign loads to the button.

B1.3	<input type="radio"/> Toggle		
Select Btn Type	<input type="radio"/> Custom		
	<input type="radio"/> Enter Override		
	<input type="radio"/> Exit Override		
			Next

Keypads: "Select Loads" Screen
After assigning button functions to keypads either manually or automatically, the "Select Loads" screen appears. If a button is set to *On, Off, Toggle, or Custom*, the loads affected by the button press must be selected. Affected loads have the function listed next to the load ID. Unaffected loads have "-" next to the load ID.
Press **Adjust** to change functions.
Set All selects all loads.
Clr All clears the functions of all loads.

B1.3	L1.1 (p,o) = On		
Select Loads	L1.2 (p,o) = - - -		
	L1.3 (o) = - - -		
	L1.4 (o) = - - -		
Set All	Clr All	Adjust	OK

Remote Keypads

Remote Keypads: "Rmte Keypd List" Screen
To program or edit remote keypads that operate with a connected control system, select "Remote Keypads" from the "Setup" screen. The GL-IPAC-SW8 allows for up to two remote keypads to be connected at ID 20 and 21 on the remote control system.
Refer to the steps described in "Keypads" on page 9 to program button functions for remote keypads.
Press **Setup** to configure the remote keypad on the "Keypad Address Setting" screen.

Rmte Keypd List	20: Not Programmed		
	21: Not Programmed		
Press	Edit	Setup	Exit

Remote Keypads: "Keypad Address Setting" Setup
Configure the remote keypad by entering the IP address of the remote control system. Press **Edit** and then use the up and down buttons to change the IP values. Press **ENTER** to advance to the next part (octet) of the IP address.

Press **Set** to confirm address. The GL-IPAC-SW8 must be restarted after altering the IP address.

NOTE: After setting the IP address of the remote control system, an EIC must be added to the remote system program. On the EIC, joins 200-219 are dedicated for the remote keypads.

Press **Clear** to delete the IP Address.

Press **Exit** to save the settings and return to the "Rmte Keypd List" screen.

Keypad Address Setting			
IP Address			
127.000.000.001			
Clear	Edit		Exit

Contact Closures

Contact Closures: "Cont. Closures" Screen
Select *Contact Closures* from the "Setup" menu to show a list of the six editable contact closures (CC3 - CC.8).

- Contact closure 1 is preprogrammed to lock the GL-IPAC-SW8.
- Contact closure 2 preprogrammed to lock all keypads in the system.
- Contact closures 3 -8 (CC.3 -CC.8) can be programmed using the same functions as the keypads, in addition to being able to lock, unlock, and lock/unlock the GL-IPAC-SW8 or the keypads.

Use the up and down arrows to highlight a contact closure and then press **Edit** to program the functions for the contact closures.

Cont. Closures	CC.3		
	CC.4		
	CC.5		
	CC.6		
		Edit	Exit

Contact Closures: "Select function" Screen
To edit the functions of a contact closure, select one from the "Select function" screen: *On, Off, Toggle, Custom, Enter Override, Exit Override, Enter/Exit Override, Enable Timeclock, Disable Timeclock, Enable/Disable Timeclock, Lock Keypads, Unlock Keypads, Lock/Unlock Keypads, Lock GL-IPAC-SW8, Unlock GL-IPAC-SW8, and Lock/Unlock GL-IPAC-SW8.*

Press **Next** to edit the controlled loads if the selection was *On, Off, Toggle, or Custom.*

Other selections navigate to the "Contact Closures" screen.
NOTE: Contact closures have maintained logic functionality.

CC.3	<input type="radio"/> On		
Select function	<input type="radio"/> Off		
	<input type="radio"/> Toggle		
	<input type="radio"/> Custom		
			Next

(Continued on following page)

4 Setup: Contact Closures (Continued)

Contact Closures: "Select Loads" Screen

If a contact closure is set to on, off, toggle, or custom then the "Select Loads" screen is displayed. *On*, *Off*, *Toggle*, and *Custom* each have different operations that can be performed:

- *On* turns lights on or allows lights to turn on based upon photo sensor light readouts.
- *Off* turns lights off with a warning that the lights are about to turn off.
- *Toggle* operates with the functionality of the *On* and *Off* mentioned above.
- *Custom* allows further modification of the above options.

Use the up and down arrows to highlight the desired load and press **Adjust** to change the contact closure settings. Press **Set All** to select all loads and **Clr All** clears the functions of all loads.

CC.3	L1.1 (p,o) = On	
Select Loads	L1.2 (p,o) = ---	
	L1.3 (o) = ---	
	L1.4 (o) = ---	
Set All	Clr All	Adjust OK

Timeclock

Timeclock: "Holiday List" Screen

NOTE: If using the **TmClk** button from the front screen proceed to the last box in the next column of this page.

To program or adjust timeclock events on the GL-IPAC-SW8, select **Timeclock** from the "Setup" menu or select the **TmClk** shortcut on the home screen. The "Holiday List" screen provides a list of holidays. A holiday is observed if the screen displays an "X" next to the holiday.

Use the up and down arrows to highlight a setting and press **Select** to observe or remove a holiday. Select --- at the bottom of the list of holidays and press **Add** to add a custom holiday. A total of 100 timeclock events can be added.

Holiday List	<input checked="" type="checkbox"/> Thanksgiving	
	<input checked="" type="checkbox"/> Thksgvg 2 Day	
	<input checked="" type="checkbox"/> Christmas	
	<input type="checkbox"/> ---	
Add		Next

Timeclock: "Timeclock Warn Setup" Screen

The "Timeclock Warn Setup" screen schedules the lights to blink as a warning before they turn off. The length of time that the warning lasts and which loads perform the warning are set in the following screens.

Press **Next** to advance to the "Timeclock Warn Time" screen.

Timeclock Warn Setup		
On the following pages set the warn time and warning loads Press Help for more info		
		Next

Use the up and down buttons to select the warn time (in minutes). The selection can range from 1 to 30 minutes. Press **Next** to advance to the "Warn Loads" screen and select the loads that blink.

Timeclock Warn Time		
Warn Time: [5] minutes		
		Next

Use the up and down buttons to highlight the desired loads and press **Select** to select the loads. Press **Set All** to select all loads. Press **Clr All** to deselect all loads. Press **Next** to configure the timeclock events.

Warn Loads	<input checked="" type="checkbox"/> L1.1	
	<input checked="" type="checkbox"/> L1.2	
	<input checked="" type="checkbox"/> L1.3	
	<input checked="" type="checkbox"/> L1.4	
Set All	Clr All	Select Next

The "Time Clock Events" screen allows the start and end of the workday to be adjusted. Events on weekdays, weekends, and holidays can also be set.

NOTE: The **TmClk** button on the home screen enters the procedure at this point.

Use the up and down buttons to highlight *Start of Workday* and press **Edit** then use the up and down buttons to select the time and **ENTER** to advance through the settings. Press **Next** to save and exit. Repeat this process for *End of Workday*.

To add additional timeclock events, highlight --- and press **Add**. The **Add** option only appears when --- is highlighted. Use the up and down arrows and the **ENTER** button to select the days the event should take place (weekdays, weekends, holidays, or custom) then press **Next**. Select *Standard*, *Sunrise*, or *Sunset* from the following screen. *Standard* allows input of a fixed time. *Sunrise* and *Sunset* use the device's astronomical clock to coordinate the event with the sunrise or sunset (+/- 2 hours).

Press **Next** to advance to the "Event Type" screen. Use the up and down buttons and the **ENTER** button to select *Lights On/Off*, *Lock Keypads*, or *Unlock Keypads*. Press **Next** if *Lights On/Off* is selected or **Done** if *Lock Keypads* or *Unlock Keypads* is selected.

Press **Exit** to save settings and return to the "Setup" screen.

Time Clock Events	Start of Workday	
	End of Workday	
	1. Wkday SS+2:00	
	2. Wkly 2:10 PM	
Edit		Exit

(Continued on following page)

4 Setup: Timeclock (Continued)

Use the up and down buttons to highlight the desired load and press **ENTER** to toggle between *Auto*, *On*, and *Off (Warn)*. Press the **All On** button to turn all loads on or **All Off** to turn all loads off. Press **All Clr** to clear all selections made. Press **OK** to save the settings and return to the "Time Clock Evnts" screen.

Event Prog	L1.1 (p,o) = On	█	
	L1.2 (p,o) = On		
	L1.3 (o) = On		
	L1.4 (o) = On		
All On	All Off	All Clr	OK

(Skip this step if not adding any custom holidays)
If adding a custom holiday, use the up and down arrows to select --- from the holiday list and press **Add**. On the "Timeclock Event-Custom" screen, add the holiday's month using the up and down buttons and then press **ENTER**. Use the up and down buttons to select the day and select **Next**.
Use the up and down buttons to select the duration of the holiday, between 1 and 99 days.
Press **Next** to return to the "Setup" menu.

Timeclock Event-Custom			
Holiday Start Date (MM-DD)			
[07]	-	25	
			Next

Ethernet Settings

Ethernet Settings: "Ethernet – DHCP" Screen
Select *Ethernet Settings* from the "Setup" menu to adjust Ethernet settings.
The GL-IPAC-SW8 can be configured to use a static IP address (DHCP is off) or to obtain an IP address from a DHCP server (DHCP is on). If disabling the DHCP mode, Ethernet settings are displayed. Use the up and down arrows to select the desired DHCP setting: On or Off.
Press **Next** to return to the "Setup" menu.

Ethernet – DHCP			
DHCP: [Off]			
			Next

About

About: "About" Screen
Select *About* from the "Setup" menu to display information about the GL-IPAC-SW8's programming and Ethernet configuration.

About			
: IPAC v4.008.0004 (Jun 1			
Pgrm: GL-IPAC Default Pr			
Compiled On: 7/18/2013 1			
			Exit

5 Accessories

The following is a list of accessories that can be used with the GL-IPAC-SW8.

KEYPADS	DESCRIPTION
C2N-CBD-P	Cameo® Keypad, Standard Mount
C2N-CBD-E	Cameo Keypad, Standard Mount
C2N-CBF-P	Cameo Keypad, Flush Mount
C2N-DB	Decorator Keypads
CNX-B2/B4/B6/B8/B12	Designer Keypad (2, 4, 6, 8, or 12 Buttons)

SENSOR MODULES	DESCRIPTION
GLS-SIM	Sensor Integration Module

PHOTOCELLS*	DESCRIPTION
GLS-LOL	Crestron Green Light Photocell, Open-Loop
GLS-LEXT	Crestron Green Light Photocell, Exterior

* Requires connection to GLS-SIM, connection to **EXT** photo input on GLS-ODT-C-CN, or connection to **SENSORS 5-8** port on GL-IPAC-SW8.

OCCUPANCY SENSORS	DESCRIPTION
GLS-ODT-C-CN	Dual-Technology Occupancy Sensor with Cresnet, 2000 Sq. Ft.
GLS-OIR-C-CN	Passive Infrared Ceiling Mount Occupancy Sensor with Cresnet, 2000 Sq. Ft.

CONTACT CLOSURE OCCUPANCY SENSORS*	DESCRIPTION
GLS-ODT-C-500	Dual-Technology Ceiling Mount Occupancy Sensor, 500 Sq. Ft.
GLS-ODT-C-1000	Dual-Technology Ceiling Mount Occupancy Sensor, 1000 Sq. Ft.
GLS-ODT-C-2000	Dual-Technology Ceiling Mount Occupancy Sensor, 2000 Sq. Ft.
GLS-OIR-C-450	Passive Infrared Ceiling Mount Occupancy Sensor, 450 Sq. Ft.
GLS-OIR-C-1500	Passive Infrared Ceiling Mount Occupancy Sensor, 1500 Sq. Ft.
GLS-OIR-W-2500	Passive Infrared Wall Mount Occupancy Sensor, 2500 Sq. Ft.
GLS-ODT-W-1200	Passive Infrared Wall Mount Occupancy Sensor, 1200 Sq. Ft.

* Requires GLS-SIM to communicate with GL-IPAC-SW8 over Cresnet or can be connected to **SENSORS 1-4** port on GL-IPAC-SW8.

CONTROL MODULES	DESCRIPTION
GLS-PLS-120/277	Power Loss Sensor
GLXX-CTRL	Cresnet Control Module
GLXX-SW16	16 Channel Switch Module and relay
GLXX-SW8	8 Channel Switch Module and relay
GLXX-HDSW8	8 Channel Heavy Duty Switch Module and Relay
GLXX-HDSW16	16 Channel Heavy Duty Switch Module and Relay
GLXP-HSW12	12 Channel High-Inrush Switch Module and Relay
GLXP-HSW8	8 Channel High-Inrush Switch Module and Relay
GLXP-SW10	10 Channel Switch Module and relay
GLXP-SW16	16 Channel Switch Module and relay

SWITCHING CABINETS	DESCRIPTION
GLPX-SW-FT-8	Green Light Express Switching Panel, 8 Circuits
GLPX-SW-FT-16	Green Light Express Switching Panel, 16 Circuits
GLPX-SW-FT-24	Green Light Express Switching Panel, 24 Circuits
GLPX-SW-FT-32	Green Light Express Switching Panel, 32 Circuits
GLPX-SW-FT-40	Green Light Express Switching Panel, 40 Circuits
GLPX-SW-FT-48	Green Light Express Switching Panel, 48 Circuits
GLPX-SW-FT-56	Green Light Express Switching Panel, 56 Circuits
GLPX-HDSW-FT-8	Green Light Express Switching Panel, 8 Circuits
GLPX-HDSW-FT-16	Green Light Express Switching Panel, 16 Circuits
GLPX-HDSW-FT-20	Green Light Express Switching Panel, 20 Circuits
GLPX-HDSW-FT-24	Green Light Express Switching Panel, 24 Circuits
GLPX-HDSW-FT-28	Green Light Express Switching Panel, 28 Circuits
GLPX-HDSW-FT-32	Green Light Express Switching Panel, 32 Circuits
GLPX-HDSW-FT-36	Green Light Express Switching Panel, 36 Circuits
GLPX-HDSW-FT-40	Green Light Express Switching Panel, 40 Circuits
GLPX-HDSW-FT-44	Green Light Express Switching Panel, 44 Circuits
GLPX-HDSW-FT-48	Green Light Express Switching Panel, 48 Circuits
GLPX-HDSW-FT-56	Green Light Express Switching Panel, 56 Circuits
GLPX-HSW-FT-8	Green Light Express Switching Panel, 8 Circuits
GLPX-HSW-FT-12	Green Light Express Switching Panel, 12 Circuits
GLPX-HSW-FT-16	Green Light Express Switching Panel, 16 Circuits
GLPX-HSW-FT-20	Green Light Express Switching Panel, 20 Circuits
GLPX-HSW-FT-24	Green Light Express Switching Panel, 24 Circuits
GLPX-HSW-FT-28	Green Light Express Switching Panel, 28 Circuits
GLPX-HSW-FT-32	Green Light Express Switching Panel, 32 Circuits

OTHER	DESCRIPTION
GLA-KEYSW-MAINTAINED	Key Switch - Maintained

POWER SUPPLIES	DESCRIPTION
GLS-PLS-120/277	Power Loss Sensor
DIN-PWS50	Wall Mount 50 Watt Cresnet Power Supply

6 Wiring Guidelines

Use the Right Wire

To ensure optimum performance over the full range of the installation topology, use Crestron Certified Wire only. Failure to do so may incur additional charges if support is required to identify performance deficiencies because of using improper wire.

Calculate Power



CAUTION: Use only Crestron power supplies for Crestron equipment. Failure to do so could cause equipment damage or void the Crestron warranty.

CAUTION: Provide sufficient power to the system. Insufficient power can lead to unpredictable results or damage to the equipment. Use the Crestron Power Calculator to help calculate how much power is needed for the system (www.crestron.com/calculators).

When calculating the length of wire for a particular Cresnet run, the wire gauge and the Cresnet power usage of each network unit to be connected must be taken into consideration. Use Crestron Certified Wire only. If Cresnet units are to be daisy chained on the run, the Cresnet power usage of each network unit to be daisy chained must be added together to determine the Cresnet power usage of the entire chain. If the unit is run from a Crestron system power supply network port, the Cresnet power usage of that unit is the Cresnet power usage of the entire run. The wire gauge and the Cresnet power usage of the run should be used in the following equation to calculate the cable length value on the equation's left side.

Cable Length Equation

$$L < \frac{40,000}{R \times P}$$

Where: L = Length of run (or chain) in feet
 R = 6 Ohms (Crestron Certified Wire: 18 AWG (0.75 mm²))
 or 1.6 Ohms (Cresnet HP: 12 AWG (4 mm²))
 P = Cresnet power usage of entire run (or chain)

Make sure the cable length value is less than the value calculated on the right side of the equation. For example, a Cresnet run using 18 AWG Crestron Certified Wire and drawing 20 watts should not have a length of run more than 333 feet (101 meters). If Cresnet HP is used for the same run, its length could extend to 1250 feet (381 meters).

NOTE: All Crestron certified Cresnet wiring must consist of two twisted pairs. One twisted pair is the **24** and **G** pair and the other twisted pair is the **Y** and **Z** pair.

Strip and Tin Wire

When daisy chaining Cresnet units, strip the ends of the wires carefully to avoid nicking the conductors. Twist together the ends of the wires that share a pin on the network connector and tin the twisted connection. Apply solder only to the ends of the twisted wires. Avoid tinning too far up the wires or the end becomes brittle. Insert the tinned connection into the Cresnet connector and tighten the retaining screw. Repeat the procedure for the other three conductors.

Add Hubs

Use of a Cresnet Hub/Repeater (CNXHUB) is advised whenever the number of Cresnet devices on a network exceeds 20 or when the combined total length of Cresnet cable exceeds 3000 feet (914 meters).

7 Troubleshooting

The following table provides corrective action for possible trouble situations. If further assistance is required, please contact a Crestron customer service representative.

PROBLEM	INSTALLATION RESOLUTION	HARDWARE RESOLUTION	SOFTWARE RESOLUTION
Occupancy sensor does not function.	Verify that the occupancy sensor is placed in the correct location by utilizing the <i>Test</i> mode on the sensor. For additional details refer to the occupancy sensor's installation guide at www.crestron.com/manuals .	Verify the occupancy sensors are connected correctly. If sensors are connected via GLS-SIM, verify that DIP switch settings match those listed in this guide.	Verify that occupancy sensors are associated with loads from the "Occupancy Sensor" screen.
Photo sensors do not function.	Verify that the photosensor is placed in an area where natural light is changing.	Verify the photo sensors are connected correctly. If sensors are connected via GLS-SIM, verify that DIP switch settings and dials are correct.	Verify that photo sensors are associated with loads from the photo sensor setup screen. Verify that the photo sensor levels are set such that actions occur with the level of natural light incident to the sensor. Verify that <i>Auto</i> mode is triggered by an external device.
Keypad buttons do not trigger the expected action.	Verify that the Cresnet wiring is in place and that adequate power is being supplied.	N/A	Verify that the keypad buttons have been programmed from the keypad programming screen. Verify that the loads are in a condition where they would change from a keypad button press. For example, the loads are off if the keypad action turns on the load.
Timeclock events are not occurring.	N/A	N/A	Verify that timeclock events are programmed properly. Ensure that there are no timeclock overrides present. Verify that the date and time of the GL-IPAC-SW8 are set correctly.
Contact closures do not function.	Verify that the contact closure is being triggered.	Verify that the contact closure wires are being connected to the contact closure input and to the ground terminal. Verify that the contact closure is capable of sinking 10 mA of current and it does not provide current to the input terminal.	Verify the contact closure input is programmed via the "Contact Closure" screen.
A city is not available from the "Project Settings" screen.	N/A	N/A	Select a city that is geographically close and in the same time zone as the current city. The location selection allows for accurate calculation of sunrise and sunset times. Selecting a nearby city may cause the sunrise and sunset times to be off by a few minutes.
External loads are not being controlled.	Verify that the modules attached to the GL-IPAC-SW8 are supported. Refer to "Accessories" on page 13 for a list of supported devices.	Verify that Cresnet wiring is properly wired between the GL-IPAC-SW8 and the external panel. Verify that the modules within the panel are wired properly. Refer to "Wiring Diagram" on page 2 for wiring information.	Verify that the modules IDs have been properly set according to the "Panels" setup option.

The specific patents that cover Crestron products are listed at patents.crestron.com.

Crestron, the Crestron logo, Crestron Green Light, Cameo, and Cresnet are either trademarks or registered trademarks of Crestron Electronics, Inc. in the United States and/or other countries. Other trademarks, registered trademarks, and trade names may be used in this document to refer to either the entities claiming the marks and names or their products. Crestron disclaims any proprietary interest in the marks and names of others. *Crestron is not responsible for errors in typography or photography.*

This document was written by the Technical Publications department at Crestron.
 ©2014 Crestron Electronics, Inc.