

Assembly Instructions

CM7295D

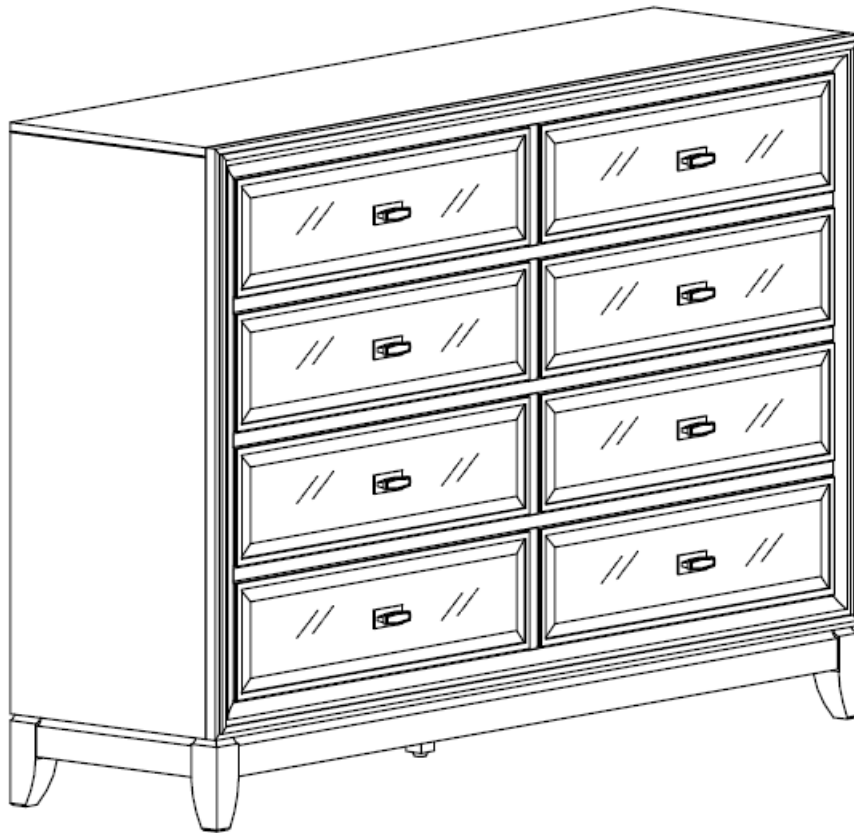

ASSEMBLY RATING

The Assembly Rating is a 5-point system that shows the degree of effort needed in assembling a specific product (with 1 being easy and 5 being difficult). For some products, two persons are recommended.

EASY  DIFFICULT

Tools Required for Assembly:

Allen Wrench



(Included)

Phillips Screwdriver



(Not Included)



2 PERSONS RECOMMENDED

ASSEMBLY & CARE ADVICE

FOR YOUR FURNITURE TO LAST, CORRECT ASSEMBLY AND PROPER MAINTENANCE ARE NECESSARY. PLEASE FOLLOW THE INFORMATION PROVIDED BELOW TO FULLY ENJOY YOUR FURNITURE.

BASIC ASSEMBLY TECHNIQUES

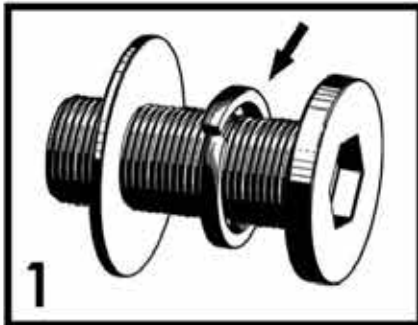

1 When lock or spring washer is used in an assembly, please make sure the lock or spring washer is placed between the larger flat washer and the head of the screw or bolt.



2 Position each part correctly and insert screws or bolts into their respective holes by hand tighten or using the proper hand tool. Only tighten when step is completed or when instructed to do so.



3 Use cardboard or carpet area when assembling furniture to prevent scratches. Make sure the furniture rests on a flat and level surface with each leg evenly touching the floor.

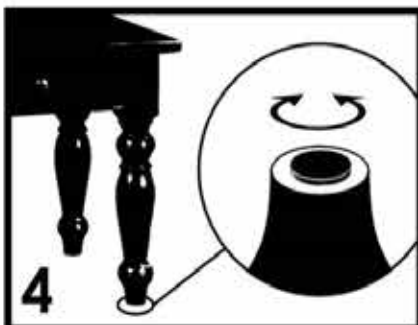

4 Some furniture comes with height adjustment knobs underneath each leg. To lower or to raise each leg, you need to turn clockwise or counterclockwise, respectively.

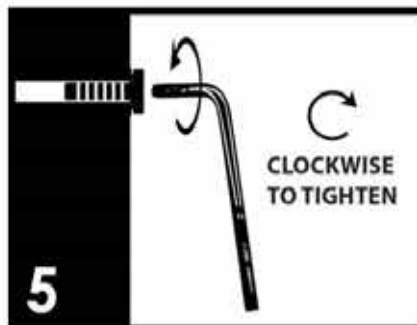

5 Make sure all parts are properly aligned, then use the appropriate hand tool to completely tighten the bolts or screws. Do not use power tools and do not overtighten.

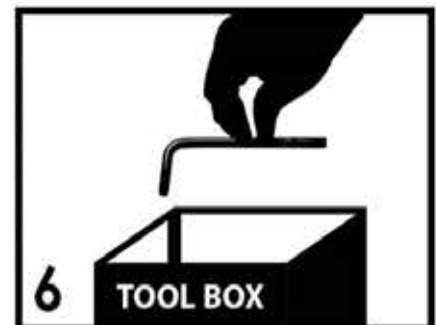

6 Save the instructions and store the Allen wrench or any supplied tool for later maintenance. After two weeks, check and tighten any loose hardware and repeat again every six months thereafter.

IT IS THE USER'S RESPONSIBILITY TO MAINTAIN THE FURNITURE. THE HARDWARE MAY LOOSEN OVER TIME AND MAY CAUSE THE FURNITURE TO BE WOBBLY AND UNABLE TO SUPPORT ITS INTENDED WEIGHT CAPACITY. THIS MAY LEAD TO COLLAPSE AND MAY CAUSE SERIOUS INJURY.



FAILURE TO FOLLOW THE GUIDELINES ABOVE MAY RESULT IN INJURY AND/OR PROPERTY DAMAGE.





Before you begin, please read Page 2 of "Assembly and Care Advice".







And remember, do not tighten until each step is completed or instructed.

MD

Parts List

-  #1 x 1 pc
Dresser
-  #2 x 4 pcs
Leg
-  #3 x 1 pc
Center Leg

Hardware List

-  #A x 8 pcs
Bolt 5/16" x 1-3/4"
-  #B x 8 pcs
Flat Washer
-  #C x 8 pcs
Lock Washer
-  #D x 1 pc
Allen Wrench
-  #E x 8 pcs
Knob
-  #F x 16 pcs
Screw 5/32" x 1"
-  #G x 48 pcs
Plastic Washer



Due to the size and/or weight of this product, it is highly recommended that the assembly should be done near the area of its intended location. Make sure you have enough space to move around during the assembly. ALWAYS have at least two people to help with transporting and assembling the product to avoid any potential injury and/or damage.



#1

#A x 8 pcs
#B x 8 pcs
#C x 8 pcs

- I. With the help of another person, carefully place the dresser (#1) on its back over a protected surface. Align the 4 legs (#2) with the pre-drilled holes on the bottom corners of the dresser (#1).
- II. Prepare 8 bolt assemblies by inserting FIRST the lock washer (#C) onto the bolt (#A) and then the flat washer (#B) onto the SAME bolt (#A), in that order.
- III. Insert the bolt assemblies through the dresser (#1) using the Allen wrench (#D) to lock them with the 4 legs (#2).

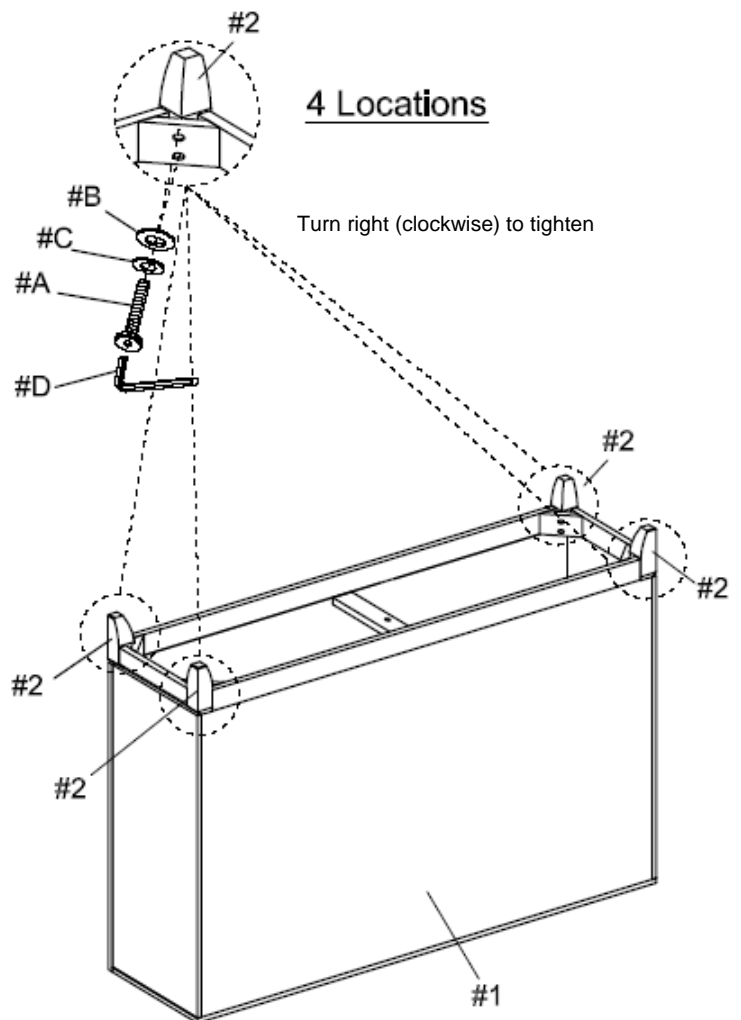

#2

- I. Align the threaded end of the center leg (#3) with the pre-drilled hole on the bottom center of the dresser (#1) and tighten by hand until secured.
- II. Carefully place the dresser on its upright position.
- III. Adjust the leveler according to the ground level. To lower or to raise the center leg (#3), you need to turn the leveler clockwise or counterclockwise, respectively.

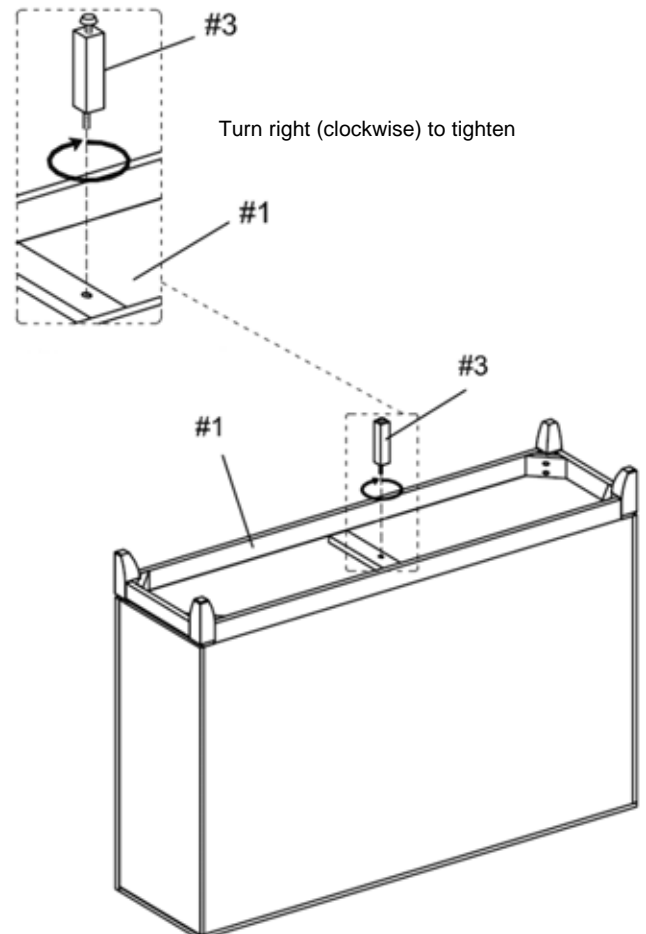



#E x 8 pcs
#F x 16 pcs
#G x 48 pcs

8 Locations

- I. Prepare the assembly of the knob (#E) to the drawer of the dresser (#1) by using 6 plastic washers (#G) and two screws (#F). See diagram for the correct sequence in connecting those parts.
- II. Secure the screws (#F) from the inside of the drawer using a Phillips screwdriver to HAND-TIGHTEN. **Caution:** Do not use power tool and do not over-tighten for damage to the glass surface may result.
- III. Repeat the above process to assemble the remaining 7 knobs (#E) onto the drawers.

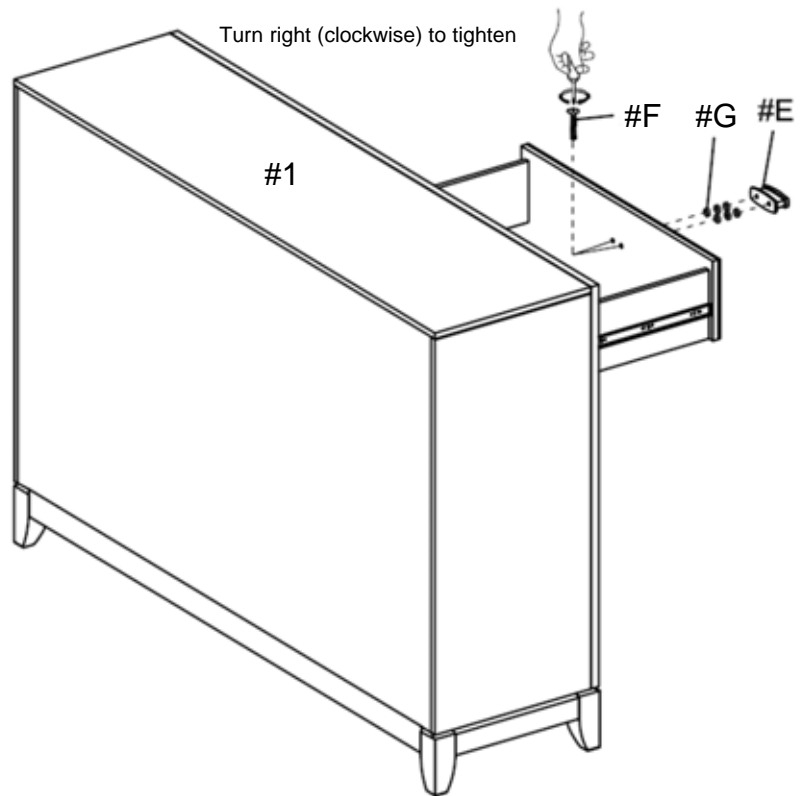



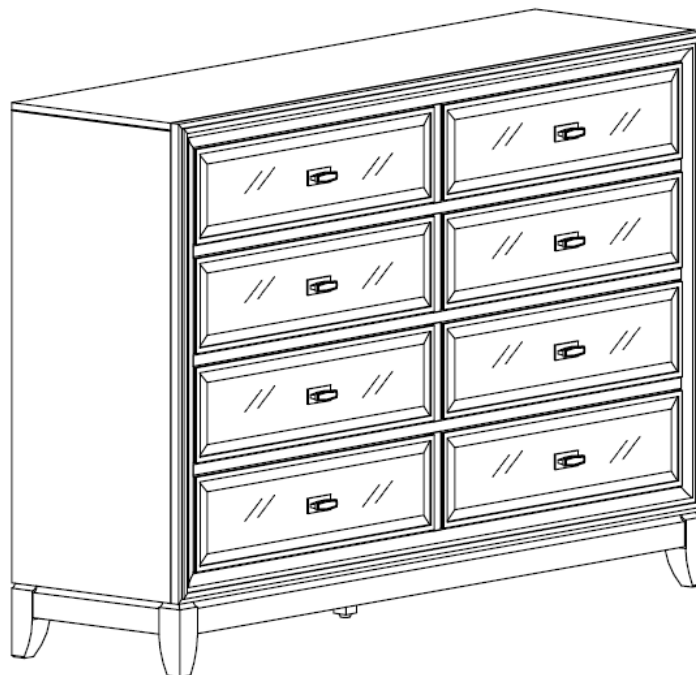

Make sure the dresser is rested on a flat surface and it does not feel loose or wobbly. If it does, double check that the bolts/screws are secured and properly tighten.



ASSEMBLY IS COMPLETED

SAFETY STRAP TO PREVENT TIP-OVER

HARDWARE LIST			
#	DRAWING	DESCRIPTION	QTY
#A		CABLE TIE	1PC
#B		BRACKET	2PCS
#C		ANCHOR	2PCS
#D		SCREW Ø4x1"	2PCS
#E		SCREW Ø4x11/16"	2PCS

Attach a bracket (#B) onto the back of the dresser using a Phillips screwdriver to secure it with 2 screws (#E).

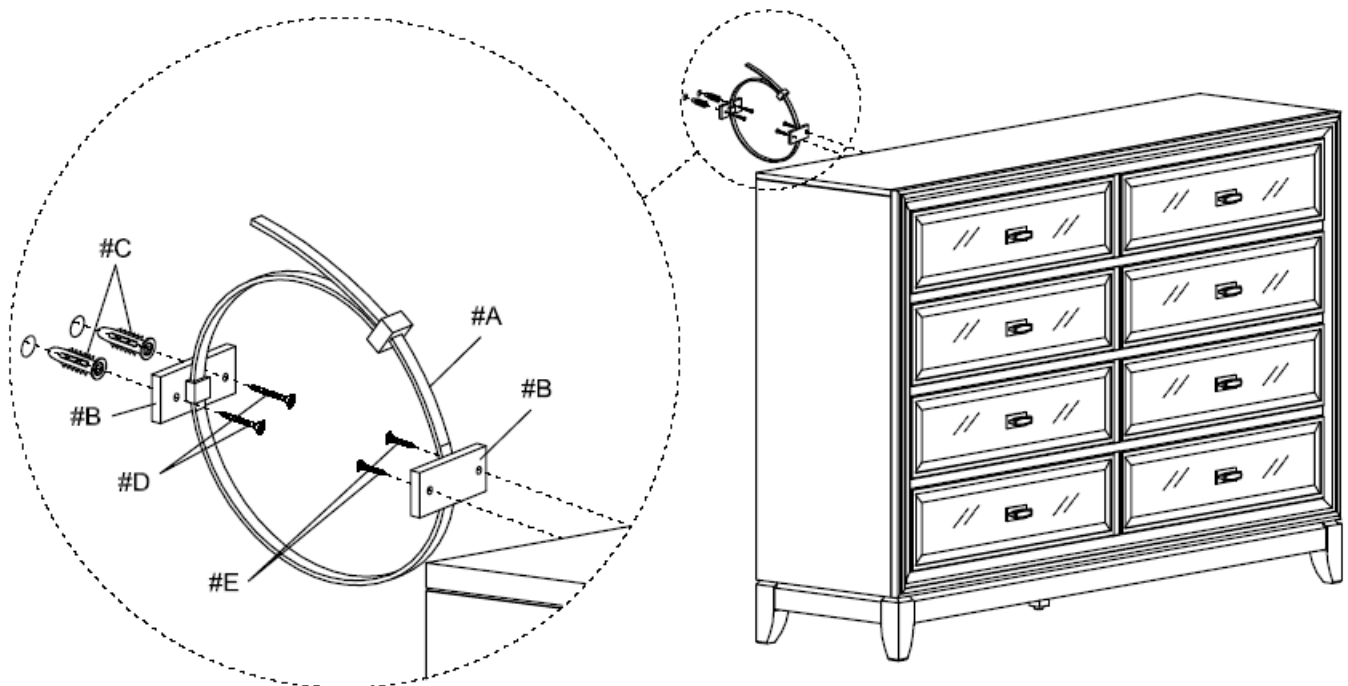

Drywall: Select a location where you want the dresser to be strapped. Mark on the wall the location where the anchors (#C) will be placed. Drill two holes slightly smaller than the size of the screw (#D). Push the anchor (#C) as far as it will go with your finger. Tap gently with a hammer until the anchors (#C) are flush with the wall surface. Secure the bracket (#B) using a Phillips screwdriver to tighten the two screws (#D) into the anchors (#C). Insert the flat end of the cable tie (#A) through the bracket (#B) from the wall and through the bracket (#B) from behind the dresser and finally through the open casing on the other side of the cable tie. Continue pulling the flat end until the loop is tighten and locked.

- OR -

Wood Stud (Recommended): Find a wood stud behind the wall (no anchor is needed for wood stud). Mark on the wall the location where the bracket (#B) will be placed. Drill two holes smaller than the size of the screw (#D) into the wood stud. Align the bracket (#B) with the drilled holes and tighten the screws (#D) using a Phillips screwdriver to secure the bracket (#B). Insert the flat end of the cable tie (#A) through the bracket (#B) from the wall and through the bracket (#B) from behind the dresser and finally through the open casing on the other side of the cable tie. Continue pulling the flat end until the loop is tighten and locked.