



12MP Elite Dome Network Camera 2.0

Quick Start Guide

Table Of Contents

Features and Specifications

- A. Overview 2
- B. Cable Interface 2

Camera Installation

- A. Installation Steps 3-4
- B. Restore Factory Defaults and Installing SD card 5

Quick Configuration Tool

- A. Overview 5
- B. Operation 5-6

Web Operation

- A. Network Connection 7
- B. Login and Logout 7-8

Appendices

- C. FAQ 9
- D. Toxic or Hazardous Elements 9-10

IMPORTANT SAFEGUARDS AND WARNINGS

Electrical Safety

All installation and operation here should conform to your local electrical safety codes. The power shall conform to the requirement in the SELV (Safety Extra Low Voltage) and the Limited power source is rated 12V DC in the IEC60950-1. This series product supports PoE too. Please note: Do not connect these two power supplying sources to the device at the same time; it may result in device damage! We assume no liability or responsibility for all the fires or electrical shock caused by improper handling or installation. We are not liable for any problems caused by unauthorized modification or attempted repair.

Transportation Security

Care must be given to avoid heavy stress, violent vibration or water damage during transportation, storage and installation.

Installation

Do not apply power to the camera before completing installation. Please install the proper power cut-off device during the installation connection. Always follow the instruction guide the manufacturer recommended.

Qualified engineers needed

All the examination and repair work should be done by the qualified service engineers. We are not liable for any problems caused by unauthorized modifications or attempted repair.

Environment

This series network camera should be installed in a cool, dry place away from direct sunlight, inflammable, explosive substances and etc. Please keep it away from the electromagnetic radiation object and environment. Please make sure the CCD (CMOS) component is out of the radiation of the laser beam device. Otherwise it may result in CCD (CMOS) optical component damage. Please keep the sound ventilation. Do not allow the water and other liquid falling into the camera. Lightning-proof device is recommended to be adopted to better prevent lightning damage. The grounding studs of the product are recommended to be grounded to further enhance the reliability of the camera.

Daily Maintenance

Please shut down the device and then unplug the power cable before you begin daily maintenance work. Do not touch the CCD (CMOS) optic component. You can use the blower to clean the dust on the lens surface. Always use the dry soft cloth to clean the device. If there is too much dust, please use the water to dilute the mild detergent first and then use it to clean the device. Finally use the dry cloth to clean the device. Please put the dustproof cap to protect the CCD (CMOS) component when you do not use the camera.

Accessories

Be sure to use all the accessories recommended by manufacturer. Before installation, please open the package and check all the components are included. Contact your local retailer ASAP if something is broken in your package.

1A. OVERVIEW

This series network camera integrates the traditional camera and network video technology. It adopts video data collection and transmission together. It can connect to the network directly without any auxiliary device.

This series network camera uses standard H.264 video compression technology as well as H.265 which maximizes the video quality and storage.

This camera model supports IR night vision function. In the night environments, the device can use the IR light to highlight the object which is suitable for the surveillance function in the low illumination environments. The waterproof design conforms to the IP67 level. It has the sound waterproof function suitable for use in the outdoor environments.

It can be used standalone or with a network video recorder. If used standalone, it is able to utilize IC Realtime's software suite including Smart ICRSS, IC View+ and ICRSS Pro. This model also supports IC Realtime's P2P connection which allows easy remote connection.

1B. Cable Interface

See Figure 1-1 for reference. (Slight variances between models may vary)

1. **POWER:** For 12v power connection.
2. **LAN:** Ethernet port to connect with network cable. Supports PoE.
3. **Power output:** Supplies 12 VDC (2W) power for external devices
4. **I/O:** Alarm Input/ Output..
5. **RS485:** Serial control for external devices such as PTZ.
6. **LAN:** Ethernet port to connect with network cable. Supports PoE.
7. **AUDIO IN:** input for mic
8. **AUDIO OUT:** output for speaker.
9. **VIDEO:** CVBS Analog output signal.

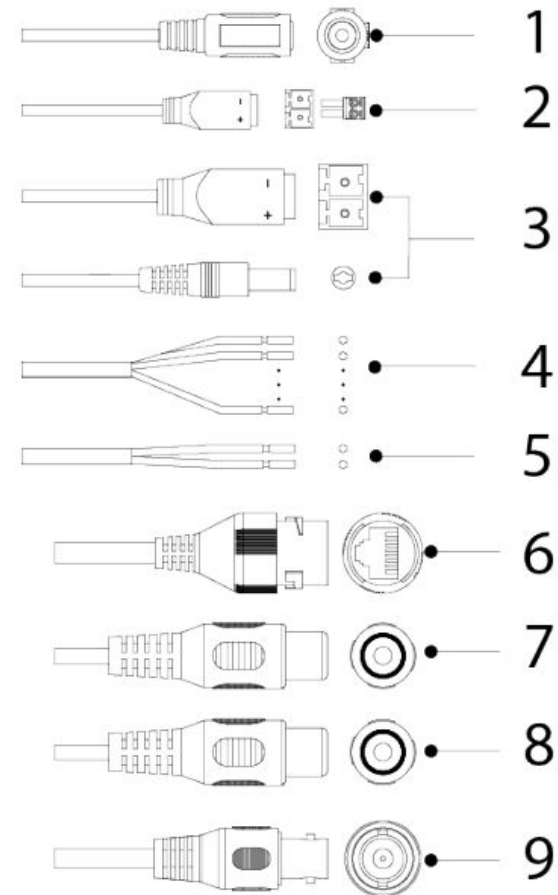

Figure 1-1

2A. INSTALLATION STEPS

Please follow the steps listed below to install the device.

Step 1 Take the device position map and place it on the mounting surface. Drill holes using the position map as a guide. Be sure to set the angle accordingly to the cable exit. If using installation surface as cable exit, drill the exit hole accordingly. See Figure 2-1.

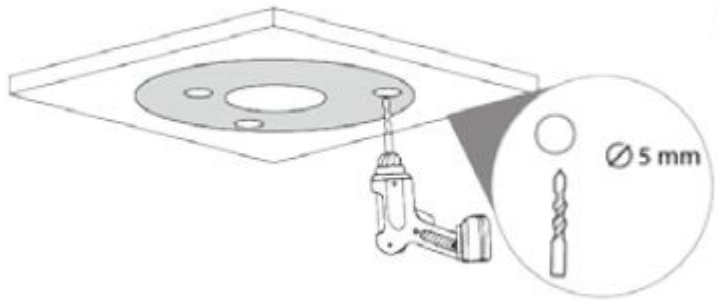

Figure 2-1

Step 2 Install the expansion screws. See Figure 2-2.

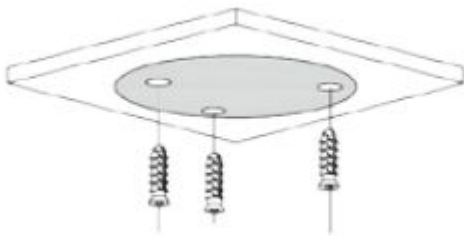

Figure 2-2

Step 3 Remove the dome from the camera body. Thread and connect the necessary wires through the cable exit. Use the Phillips head screws to mount the camera body to the anchor screws. See Figure 2-3 for side exit cabling example and Figure 2-4 for mounting surface exit cabling.

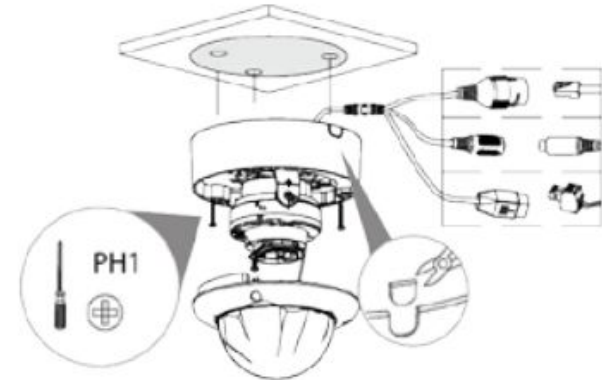

Figure 2-3

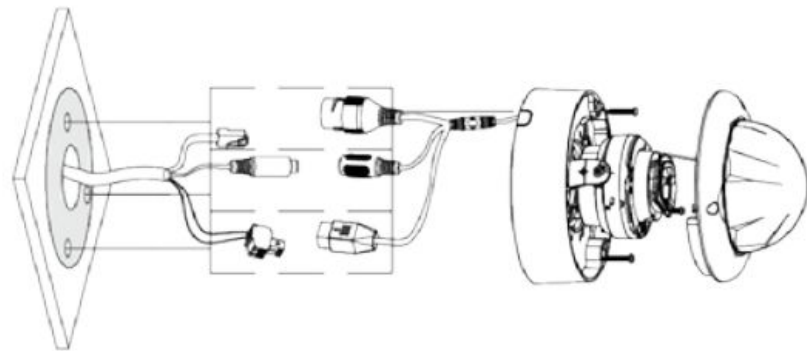

Figure 2-4

2A. INSTALLATION STEPS (Continued)

Step 4: Adjusting Lens Angle: Use the supplied hex wrench to remove the dome cover. Rotate the camera as needed. Loosen the adjustment screw in the side to adjust angle up and down. Tighten down the adjustment screw when finished. See Figure 2-5.

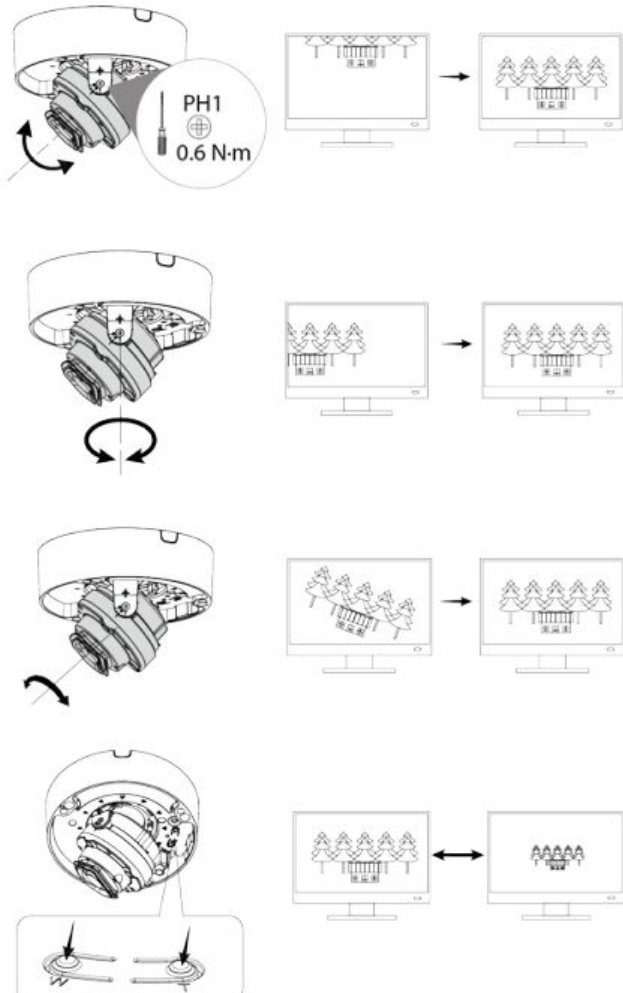

Figure 2-5

Step 5: Re-installing Dome cover: Replace the dome cover after mounting the camera, see Figure 2-6.

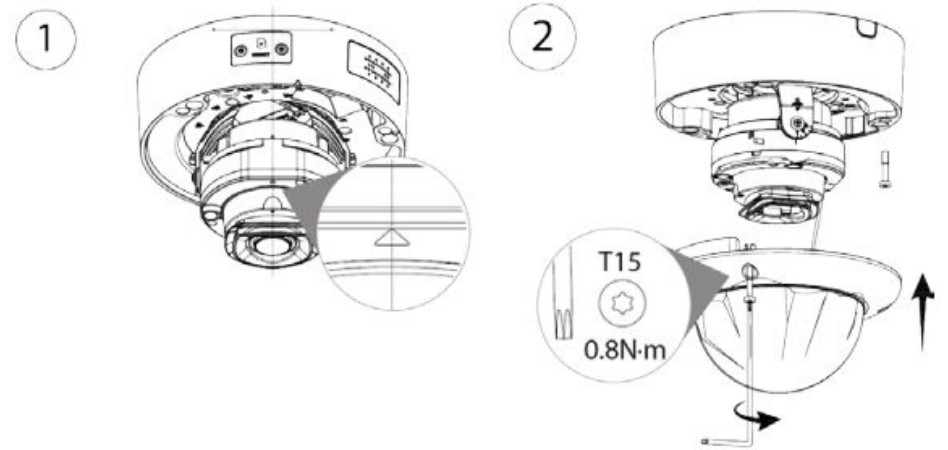

Figure 2-6

2B. RESTORE FACTORY DEFAULTS/ INSTALL SD CARD

Important: Make sure the device is powered when attempting to press **RESET** button.

Step 1 Remove the Dome from the camera body. See Figure 2-7. Skip to Step 3 if only installing SD card.

Step 2 Slightly press the RESET button for 15-30 seconds to complete the reset function. The camera will reboot when the reset process is complete.

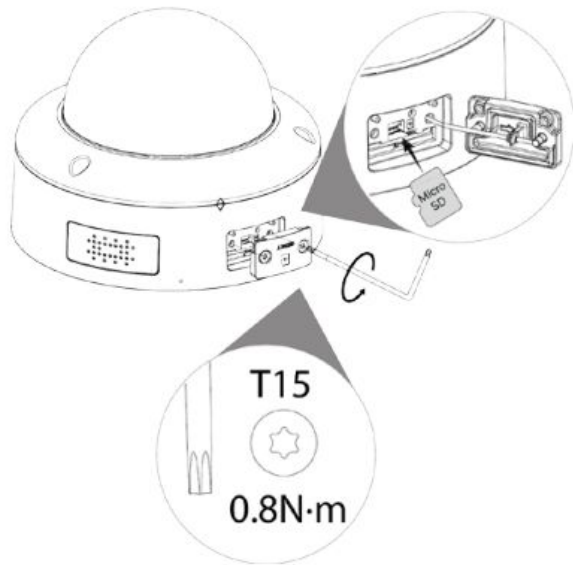

Figure 2-7

Step 3 (If installing SD Card) Adjust the Micro SD Card to a proper direction shown in Figure 2-7.

Step 5 Reinstall the dome to the camera body when finished.

3A. OVERVIEW

The IP Config tool is used to search the local network for IC Realtime devices as well as modify the IP addresses and upgrading firmware.

This software can be downloaded at:

<https://icrealtime.com/downloads> under *Desktop Utility Apps*

3B. OPERATION

Double click the “ConfigTools.exe” icon to run. The interface will be displayed as shown in Figure 3-1. Click on the blue circle icon with the two arrows to refresh and scan the network.

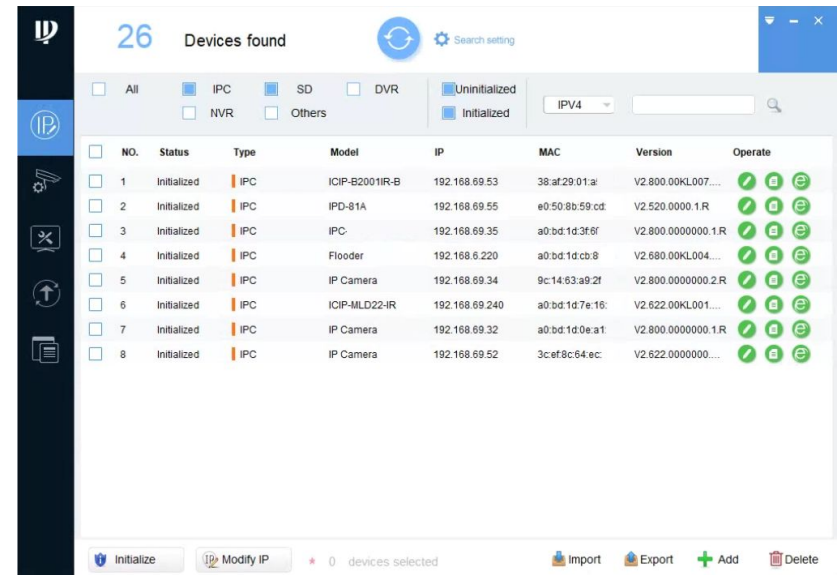

Figure 3-1

Select “Search Setting” to modify the IP range to scan for and input the correct login information for the device. See Figure 3-2.

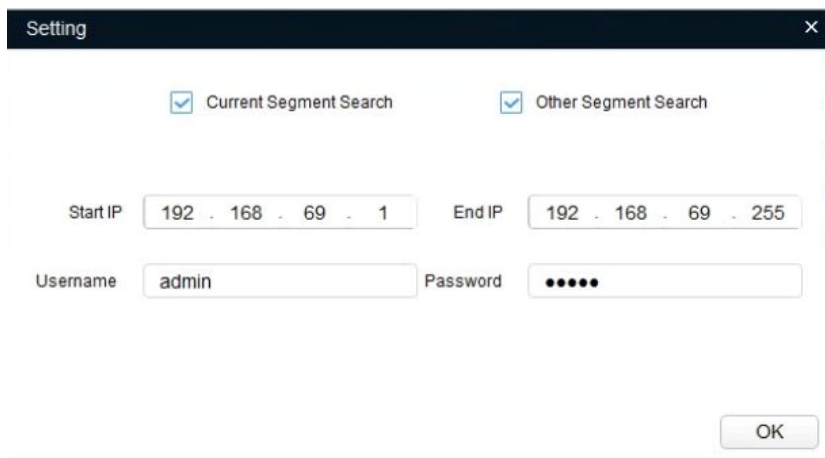

Figure 3-2

Note: If the Camera status is “Uninitialized,” select the camera and then click the “Initialize” icon on the bottom left side and follow the process on screen to initialize the device.

The Operate column will allow you to modify device, view device information and link to web browser. See figure 3-3.

Version	Operate
V2.622.0000000....	  

  
Edit IP Address Info Web GUI link

Figure 3-3

To modify the device IP address, select one of the devices from the list and then click the pencil icon. The dialog box to modify the IP information will populate. See Figure 3-4.

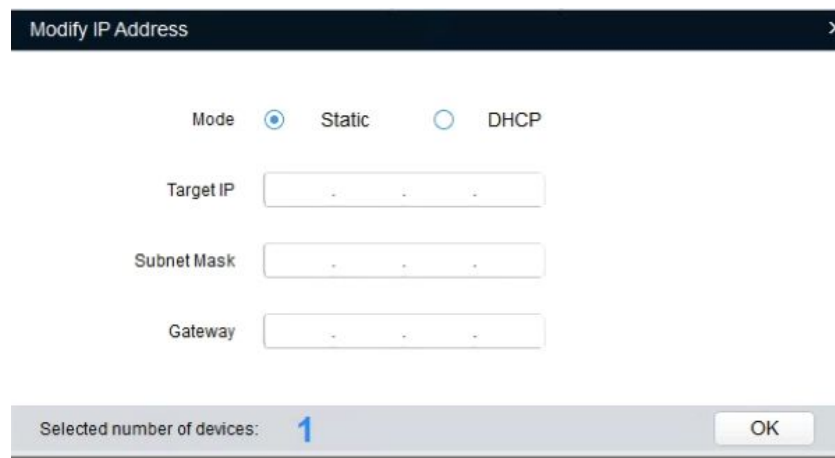

Figure 3-4

This series network camera product supports the Web access and management via PC.

4A. NETWORK CONNECTION

Please follow the steps listed below for network connection.

- Make sure the network camera is connected to the network and powered properly.
- Please set the IP address, subnet mask and gateway of the PC and the network camera respectively. The camera is set to DHCP out of the box with default IP address of 192.168.1.108 if DHCP pool is not available. Subnet mask is 255.255.255.0. Gateway is 192.168.1.1
- Using Command Prompt, type “ping ***.***.***.***(* network camera address)” to check if connection is OK or not.

4B. LOGIN AND LOGOUT

Open IE, Chrome, or Safari and input the network camera address in the address bar. See Figure 4-1.

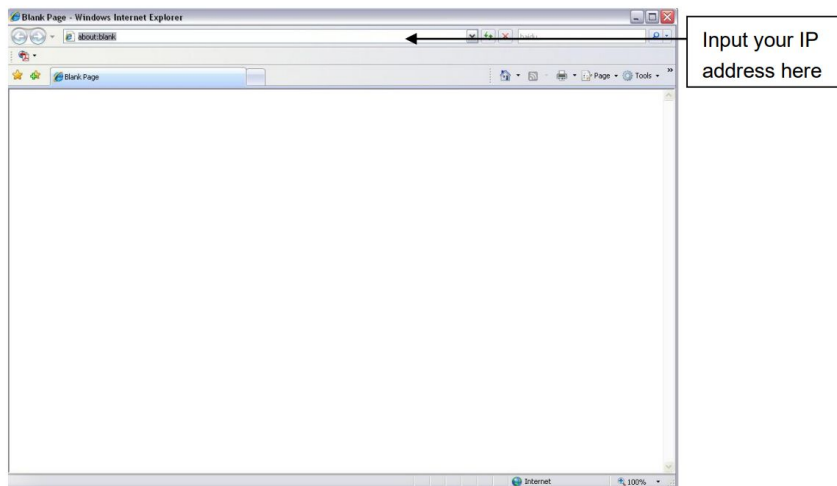

Figure 4-1

The login interface is shown as below. See Figure 4-2.

Note: If it is your first time logging into the camera (and it has not been initialized through the ConfigTool or NVR), the camera will need to be initialized. A pop-up will appear to select your region. After selecting region, you will be prompted to create a password for the admin account as well as security questions in case the password is lost. After initializing, you will be able to login to the web interface of the camera.

Please input your user name and password.

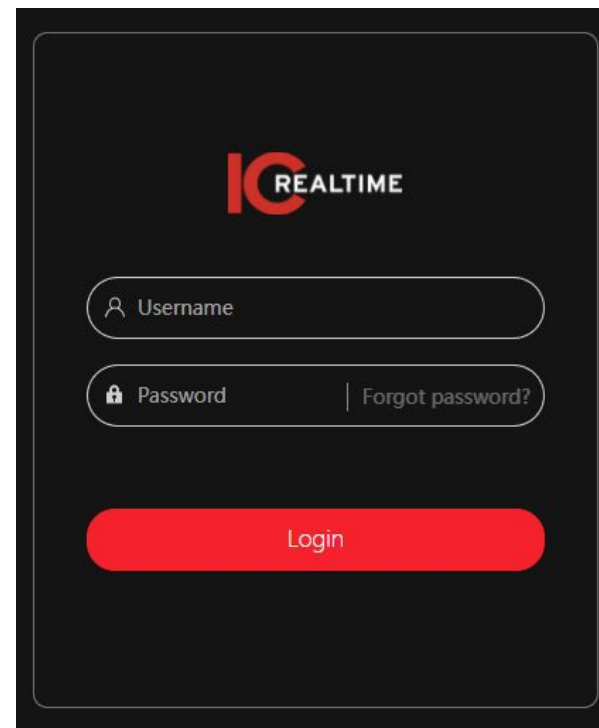





Figure 4-2

Web includes several modules: monitor channel preview, system configuration, alarm and etc. See Figure 4-3.

-  Home Page: Includes Live, AI, Camera, Event, System and Record settings
-  For configuration changes. Includes: Local (filepath), Camera, network, Event, Storage, System, Ifo and Log settings
-  Alarm: For monitoring alarm triggers (motion detect, IVS, abnormalities, etc)
-  Restart Camera/ Logout of Web UI.

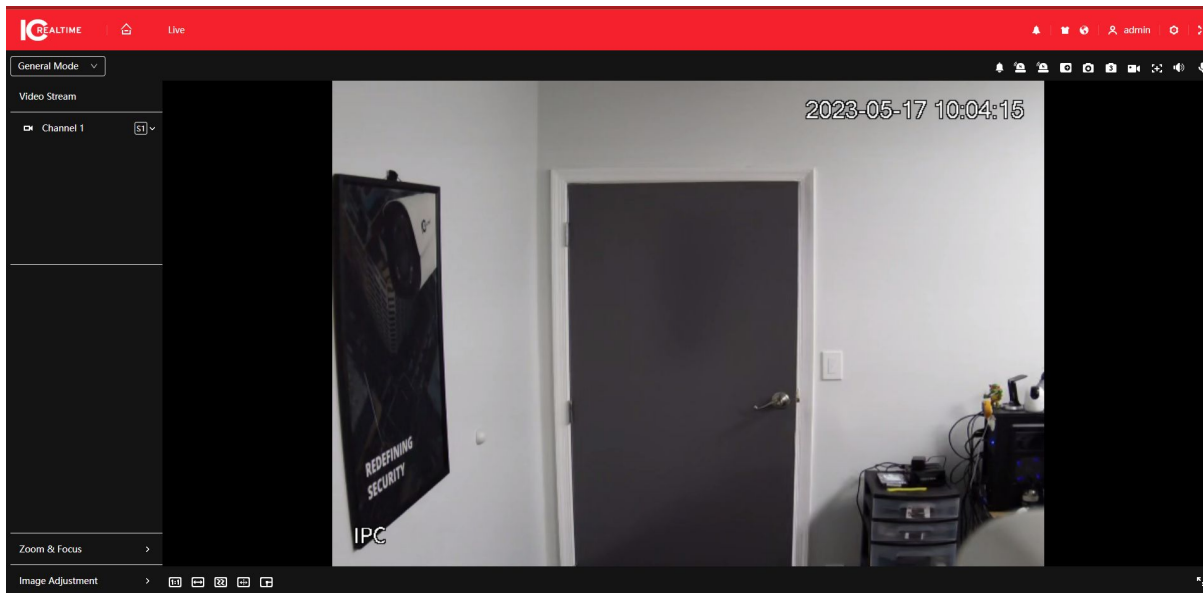

Figure 4-3

Please refer to the Web Operation Manual included in the product web page.

5A. FAQ

Device does not operate properly/ lost password.	Please refer to section 2B for factory reset process. Cam will need to be Initialized after factory reset.
The water leakage.	The front or rear cap if damaged or removed can result in water leakage. The glass dome may also have been compromised from heavy strikes or heavy pressure. The waterproof plug of the rear cap may also have loosened.
IR video is poor/ does not turn on.	Verify the camera is supplied with the recommended amount of power. You may need to test voltage/ amperage of the camera while under load. Enough visible light at the location can also cause IRs to not switch on.
I can not upgrade the device via network.	Contact technical support to request firmware.
I cannot login to the client-end or the WEB.	If the Camera HTTP port is changed, you will need to specify the port number after the IP. (ex: http://192.168.1.108:8080) Ensure the correct login credentials are being used. The Smart ICRSS software will use the TCP port. Make sure you input the correct TCP port number.
The account is locked	Reboot the camera to clear lock out. Verify the login to make sure it is correct.

P2P status is “not connected/ offline”	You may need to set device IP to DHCP. After acquiring a different IP address, verify P2P status and set camera back to static IP if successful.
Camera does not show up on local network.	Verify the camera is supplied with the recommended power supply. Change network cable or use short patch cable to troubleshoot.

5B. APPENDIX TOXIC OR HAZARDOUS MATERIALS OR ELEMENTS

Component Name	Pb	Hg	Cd	Cr VI	PBB	PBDE
Circuit Board Component	•	•	•	•	•	•
Device Case	•	•	•	•	•	•
Wire and Cable	•	•	•	•	•	•
Packing Components	•	•	•	•	•	•
Accessories	•	•	•	•	•	•

O: Indicates that the concentration of the hazardous substance in all homogeneous materials in the parts is below the relevant threshold of the SJ/T11363-2006 standard.

X: Indicates that the concentration of the hazardous substance of at least one of all homogeneous materials in the parts is above the relevant threshold of the SJ/T11363-2006 standard. During the environmental-friendly use period (EFUP) period, the toxic or hazardous substance or elements contained in products will not leak or mutate so that the use of these (substances or elements) will not result in any severe environmental pollution, any bodily injury or damage to any assets. The consumer is not authorized to process such kind of substances or elements, please return to the corresponding local authorities to process according to your local government statutes.

Note:

- This user's manual is for reference only. Slight difference may be found in user interface.
- All the designs and software here are subject to change without prior written notice.
- All trademarks and registered trademarks mentioned are the properties of their respective owners.
- If there is any uncertainty or controversy, please refer to the final explanation of us.
- Please visit our website for more information.