

Fort Worth, Texas 76140

ASSEMBLY INSTRUCTIONS

2453 - KIDS CHALKBOARD TABLETOP SET WITH TWO CHAIRS

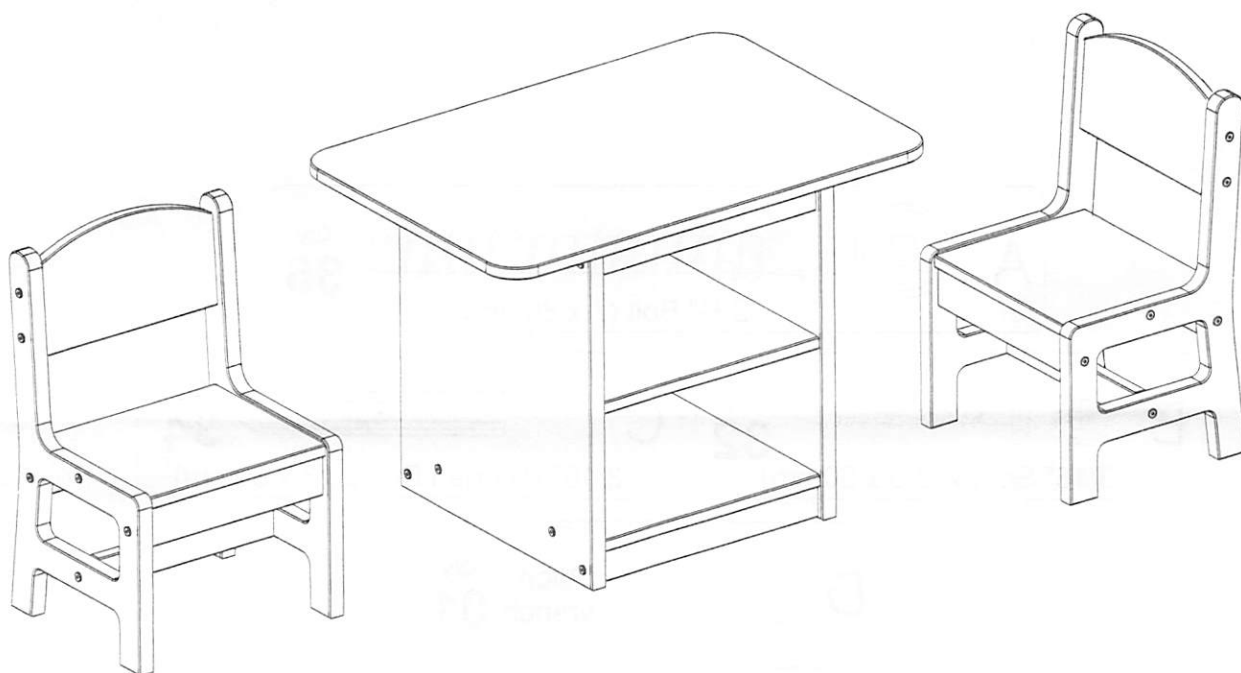

Thank you for purchasing this quality product. Be sure to check all packing material carefully for small parts which may have come loose inside the carton during shipment. Separate, identify and count all parts and hardware. Compare with the parts list to make sure that all parts are included.

"DO NOT TIGHTEN SCREWS UNTIL COMPLETELY ASSEMBLED"

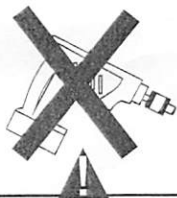

*Use of power tool to assemble this product will invalidate any claim and damage this product making unsafe !
*Please assemble on a clean soft surface to avoid damage.



Tools Required

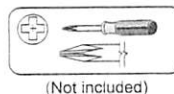

(Not included)

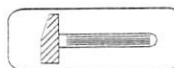

(Not included)

IMPORTANT:

PLEASE READ INSTRUCTION BEFORE STARTING THE ASSEMBLY

Identifying the Hardware-Identify the hardware using the illustrations below.

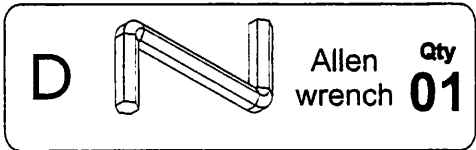
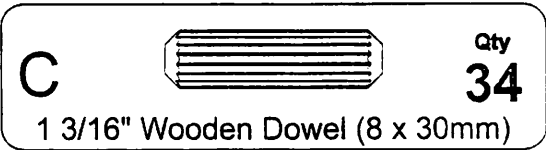
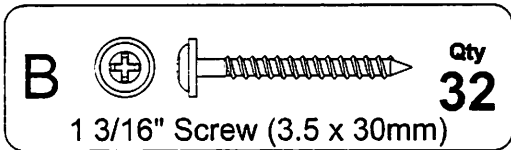
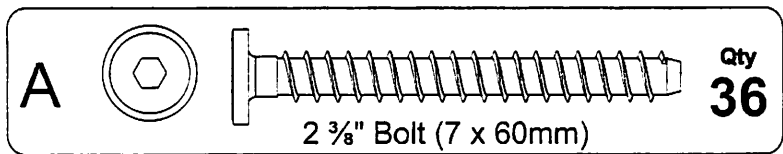

*Full size screws and bolts, for conference.

2453 - CHALKBOARD TABLETOP

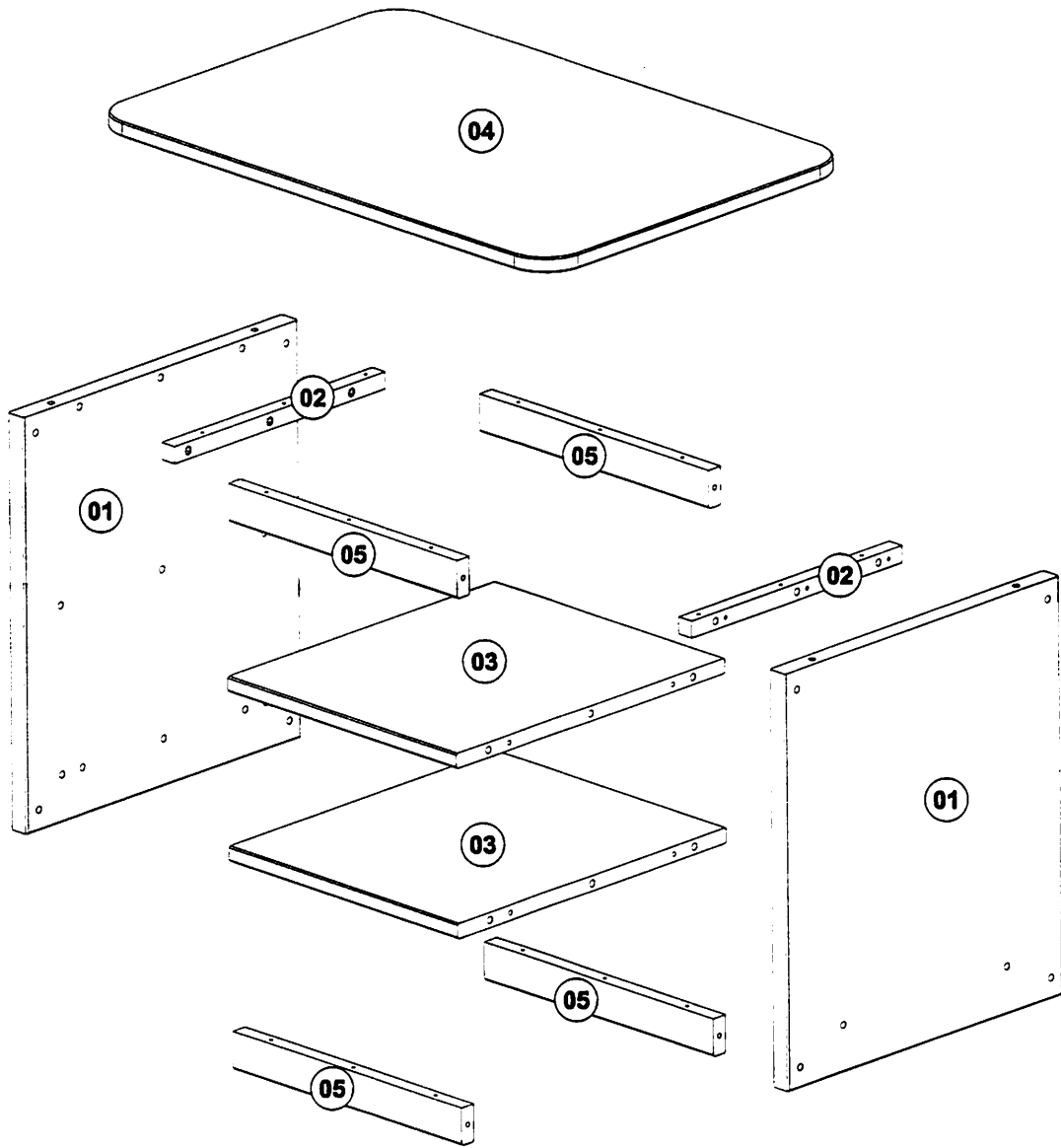

01

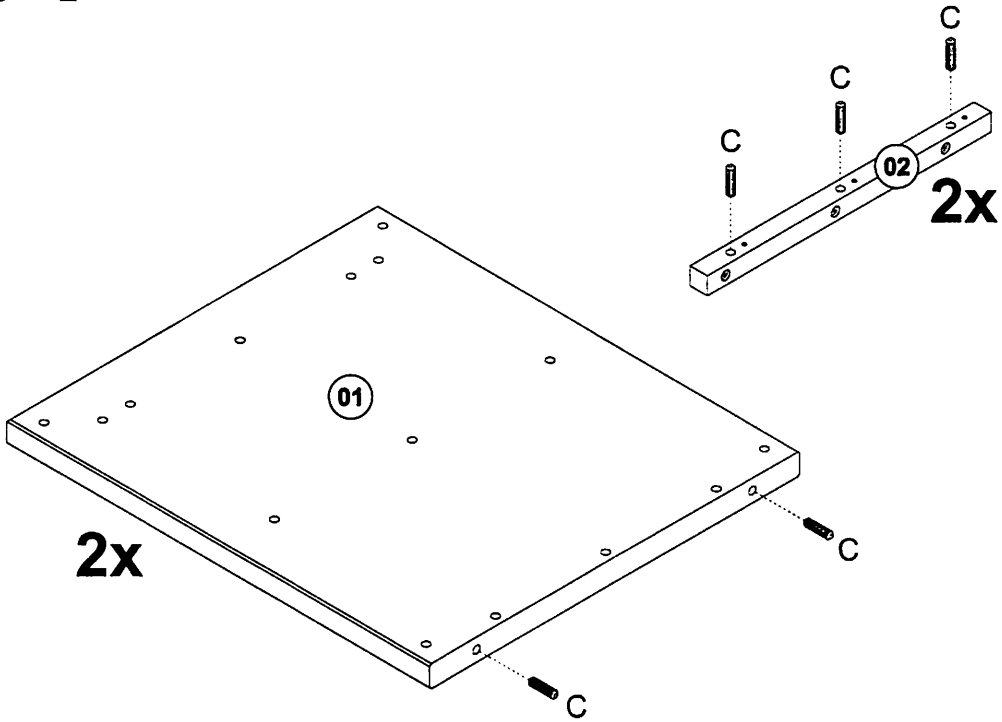
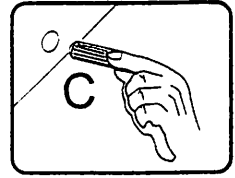
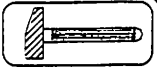

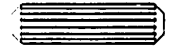
C		Qty
	1 3/16" Wooden Dowel	10

02

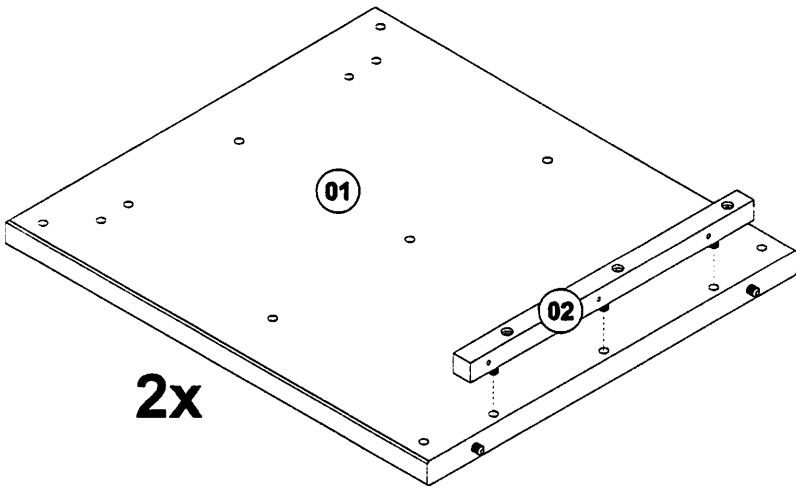
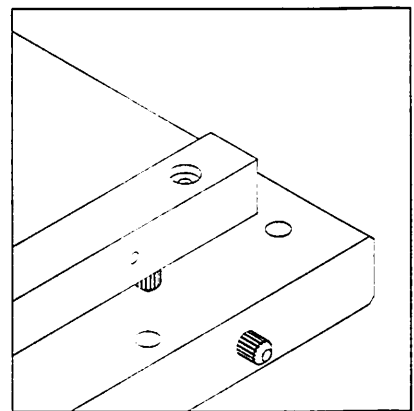

03

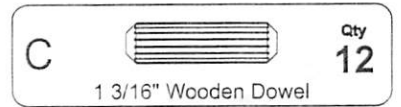
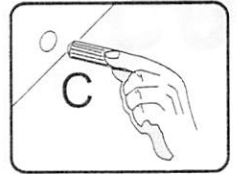
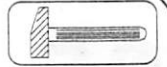
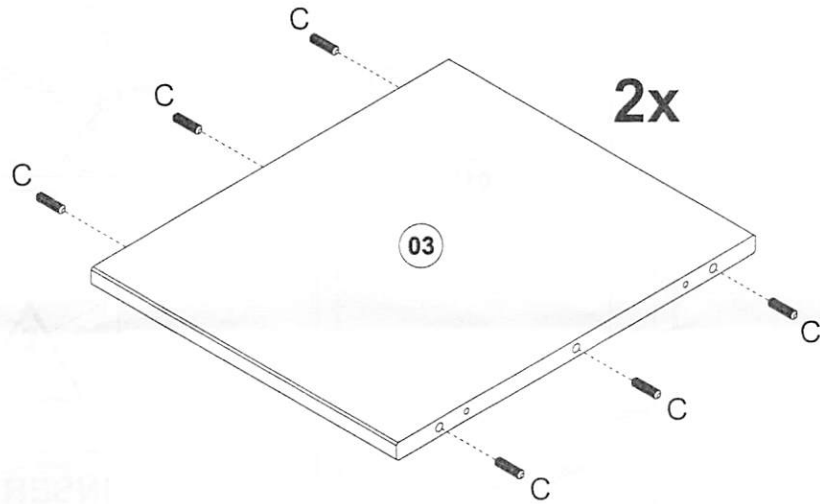

PLEASE ASSEMBLE THE TABLE ON THE GROUND, BUT FIRST PLACE SOME PROTECTIVE MATERIAL, SUCH AS A CARDBOARD BOX OR A RUG, ON THE FLOOR TO PREVENT ANY DAMAGE TO THE TABLE.

04

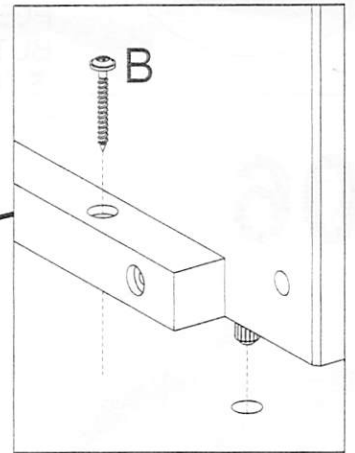
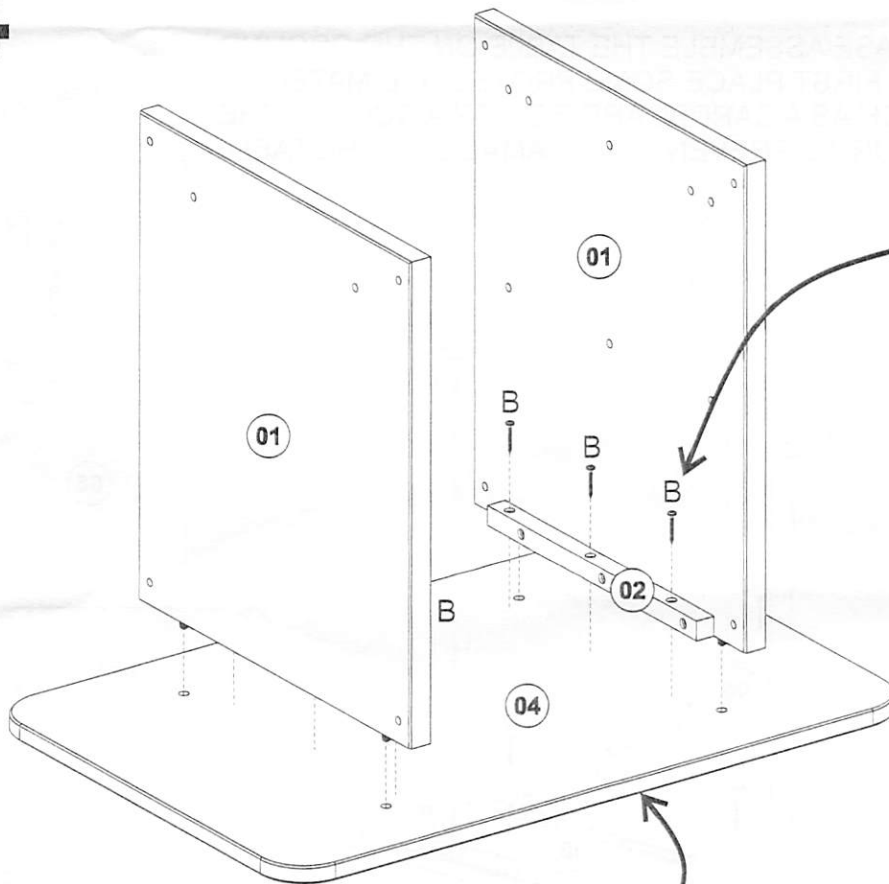

CHALKBOARD

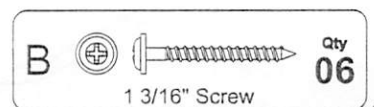
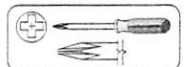

05

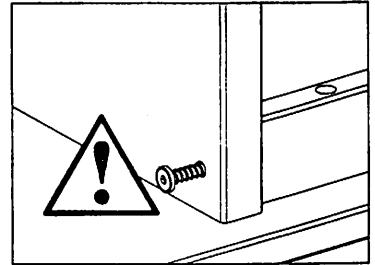
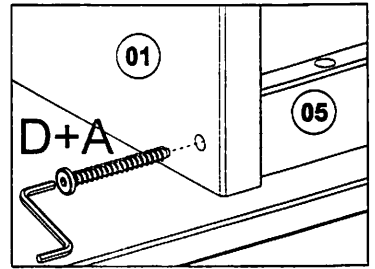
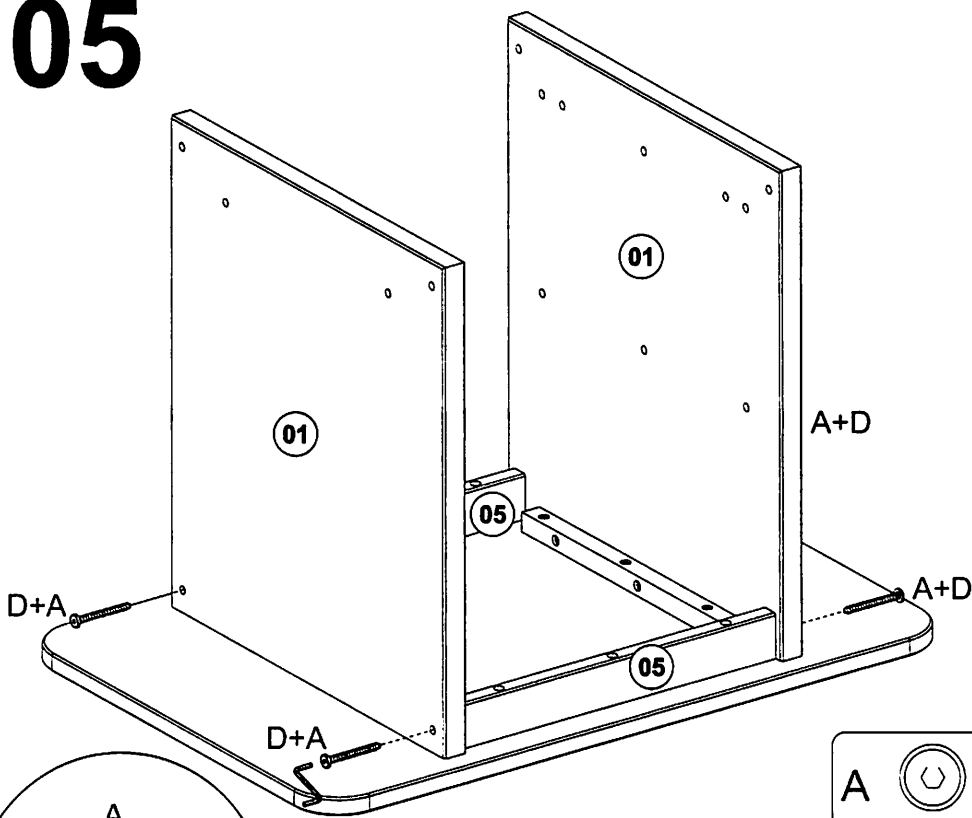

INSERT AND ATTACH BOLTS (A) BUT DO NOT TIGHTEN UNTIL STEP #7

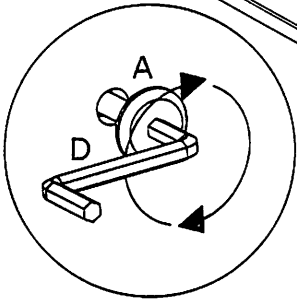
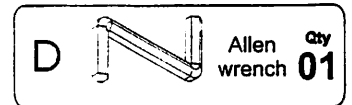
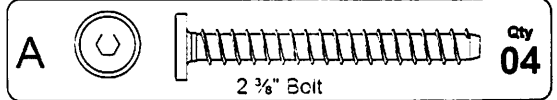

PLEASE ASSEMBLE THE TABLE ON THE GROUND, BUT FIRST PLACE SOME PROTECTIVE MATERIAL, SUCH AS A CARDBOARD BOX OR A RUG, ON THE FLOOR TO PREVENT ANY DAMAGE TO THE TABLE.

06

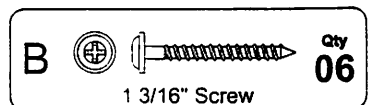
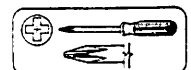
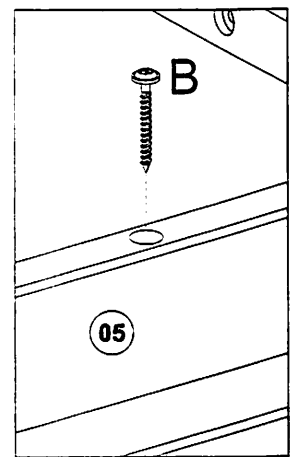
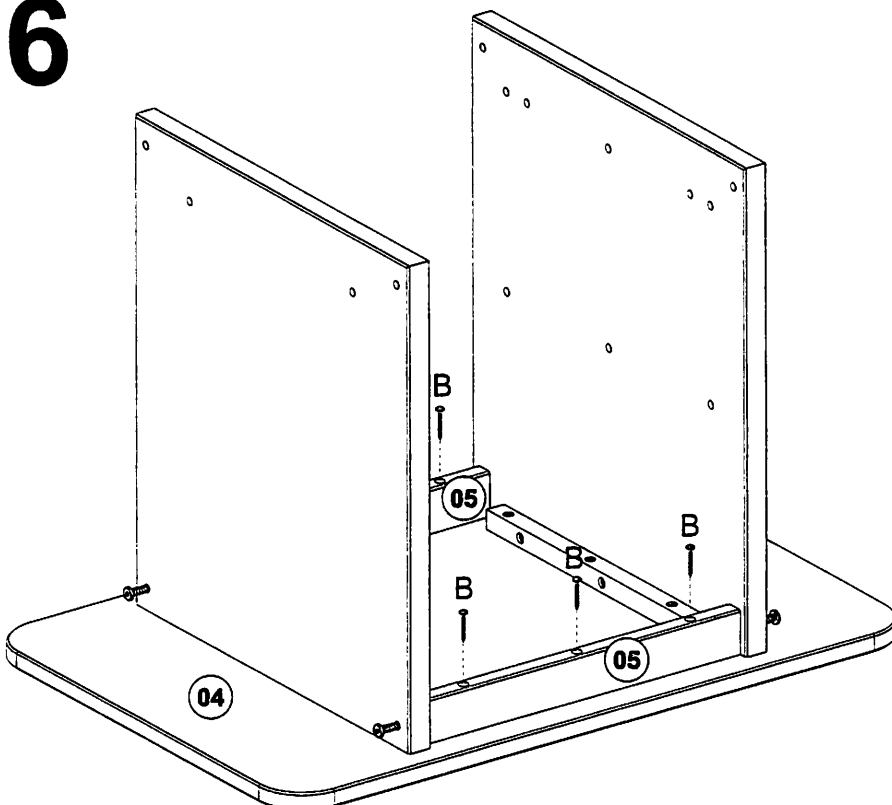

07

GENTLY MOVE THE SIDES TO FIT THE SHELVES

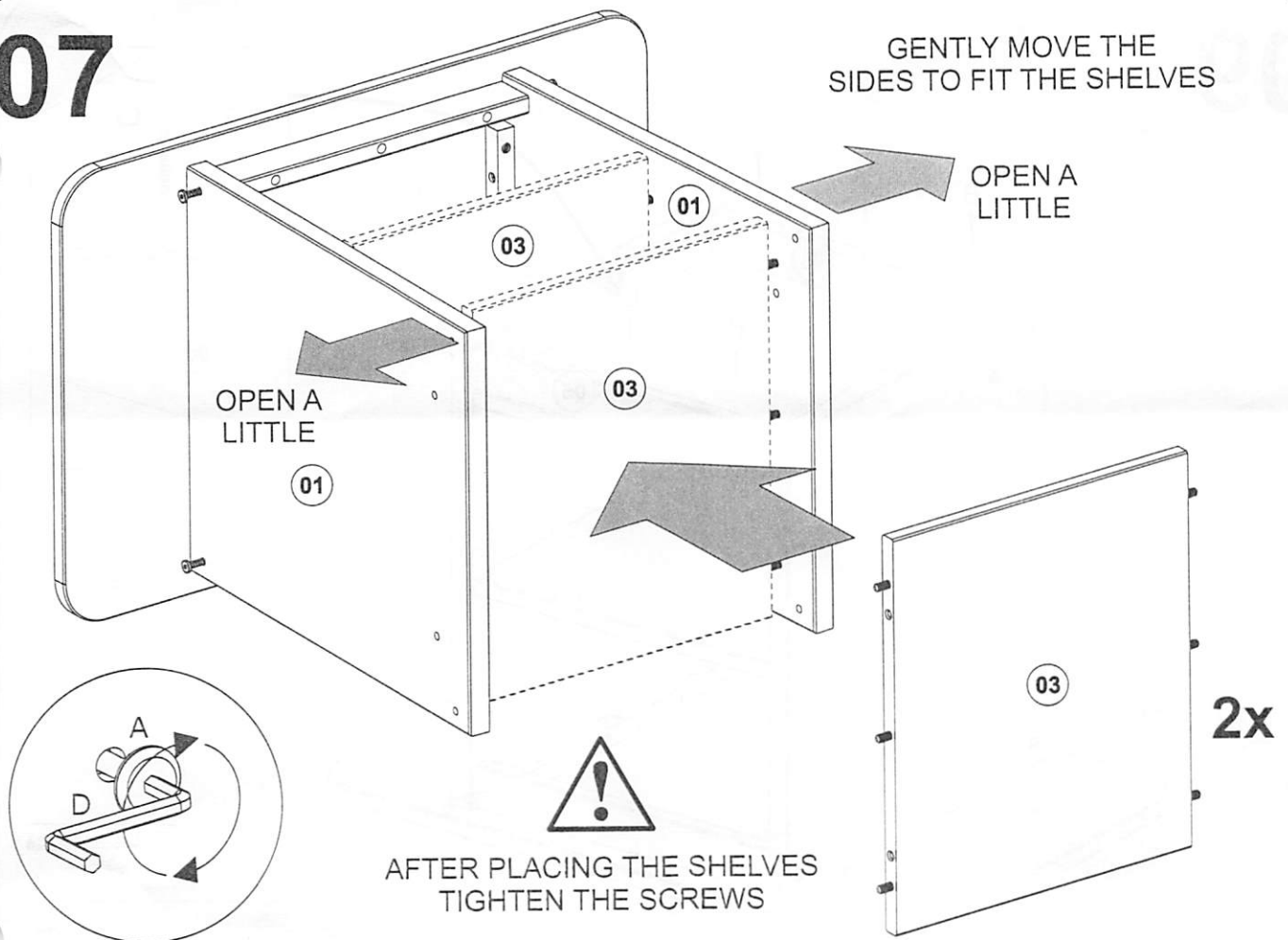

08

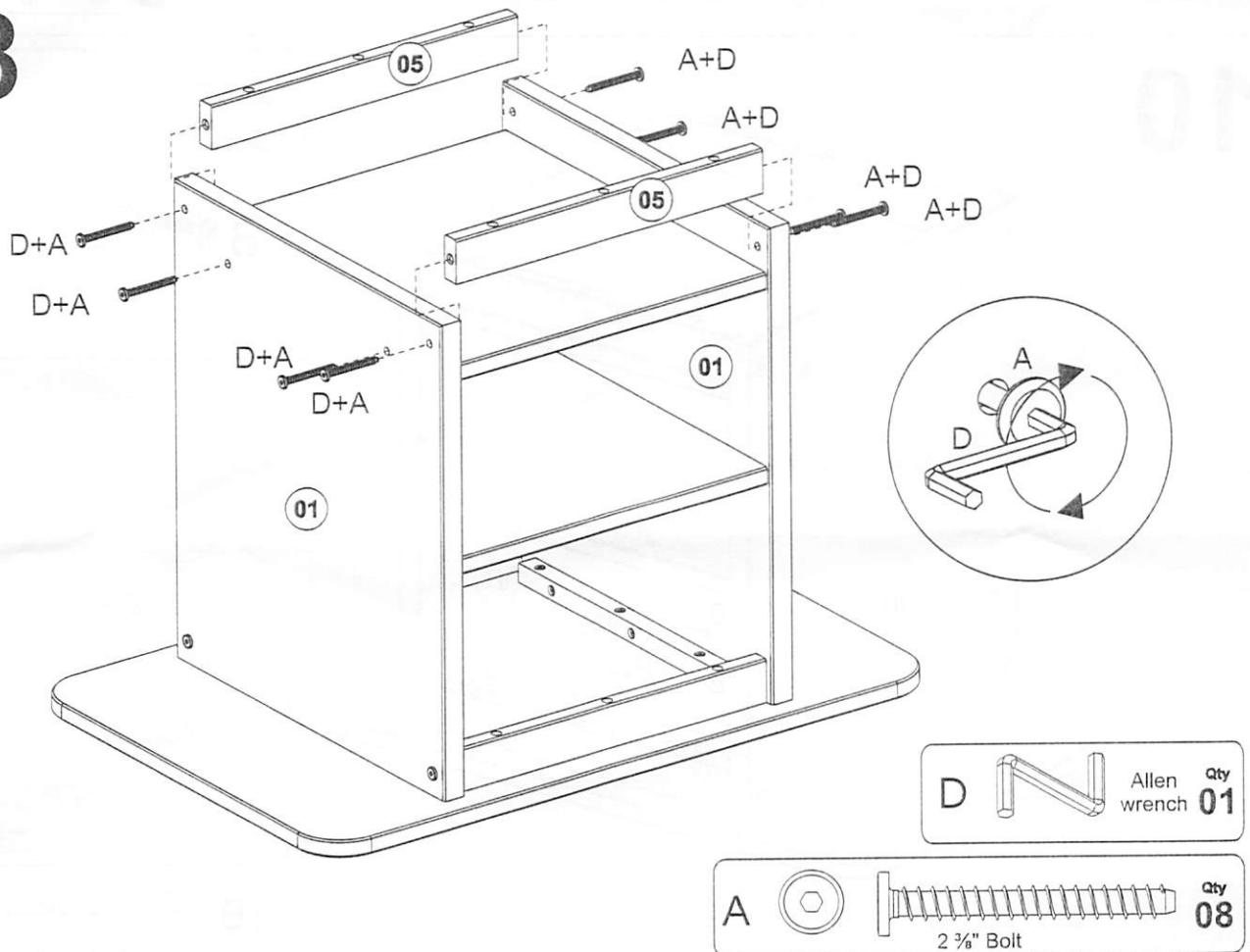

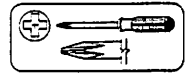
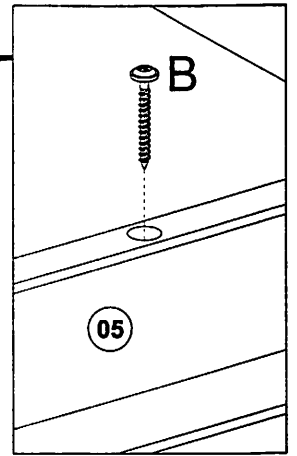
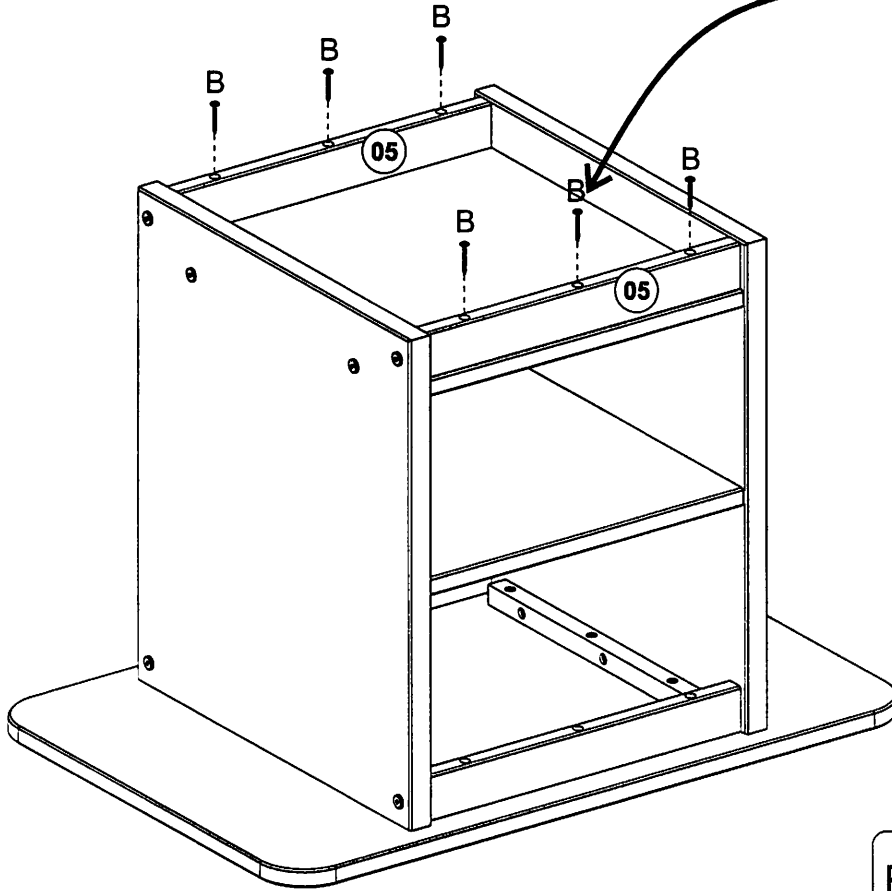

09

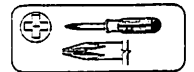
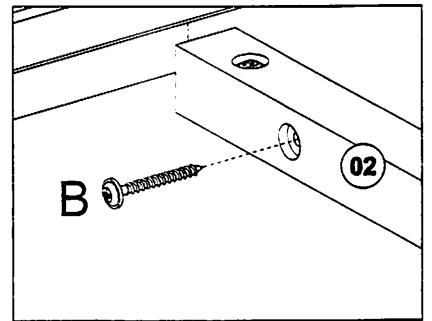
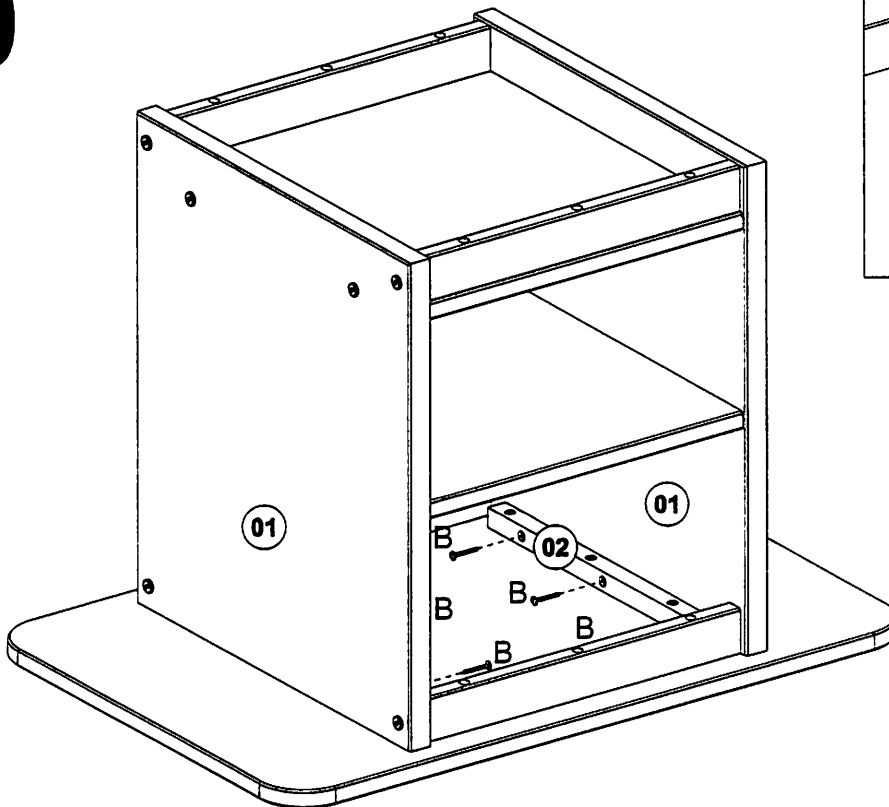

B  Qty **06**
1 3/16" Screw

10



B  Qty **06**
1 3/16" Screw

2453 - CHAIRS

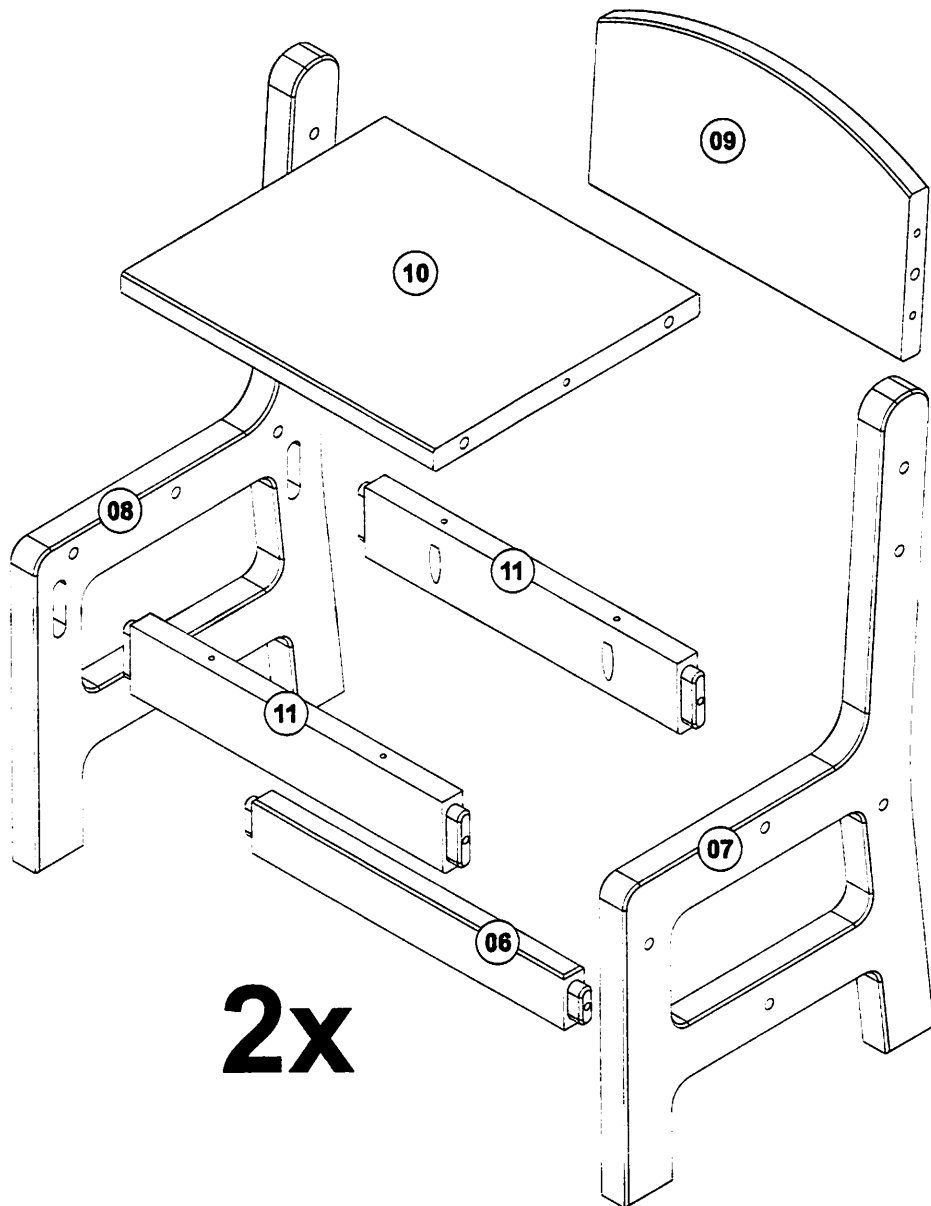

2x

11



PLEASE ASSEMBLE THE CHAIR ON THE GROUND, BUT FIRST PLACE SOME PROTECTIVE MATERIAL, SUCH AS A CARDBOARD BOX OR A RUG, ON THE FLOOR TO PREVENT ANY DAMAGE TO THE CHAIR.

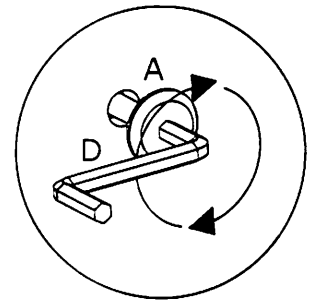
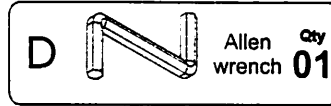
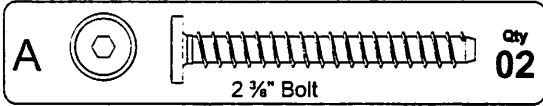
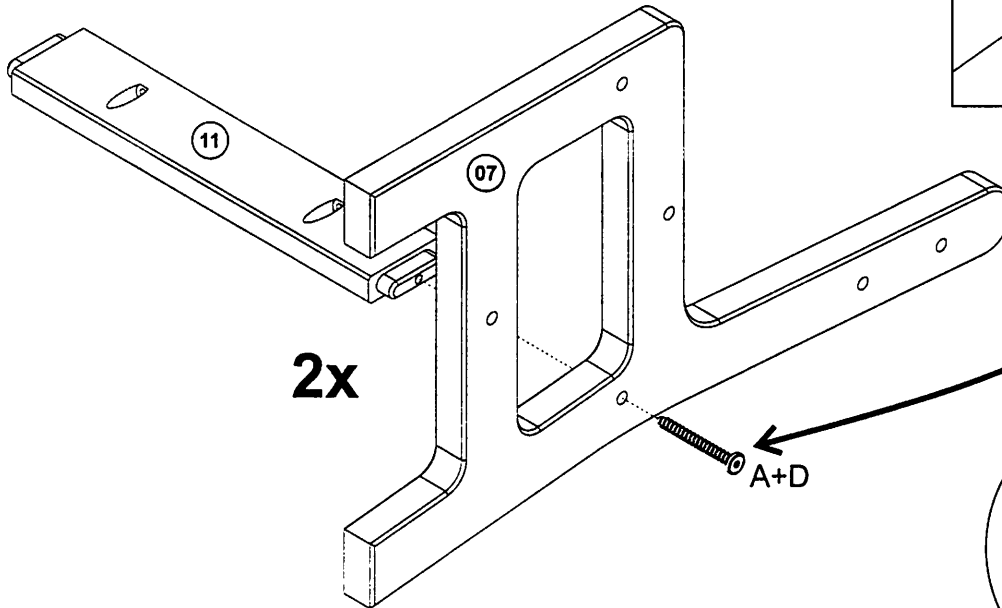
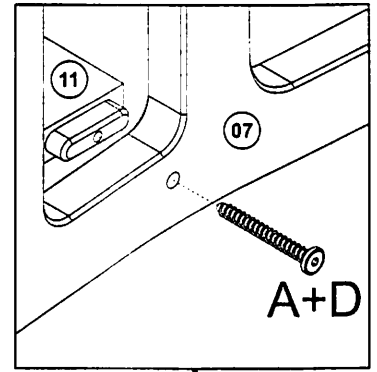

12

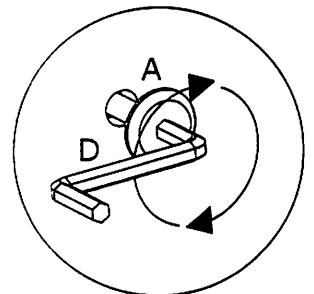
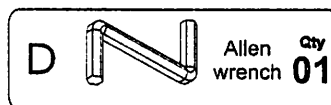
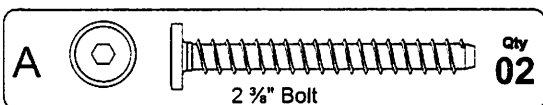
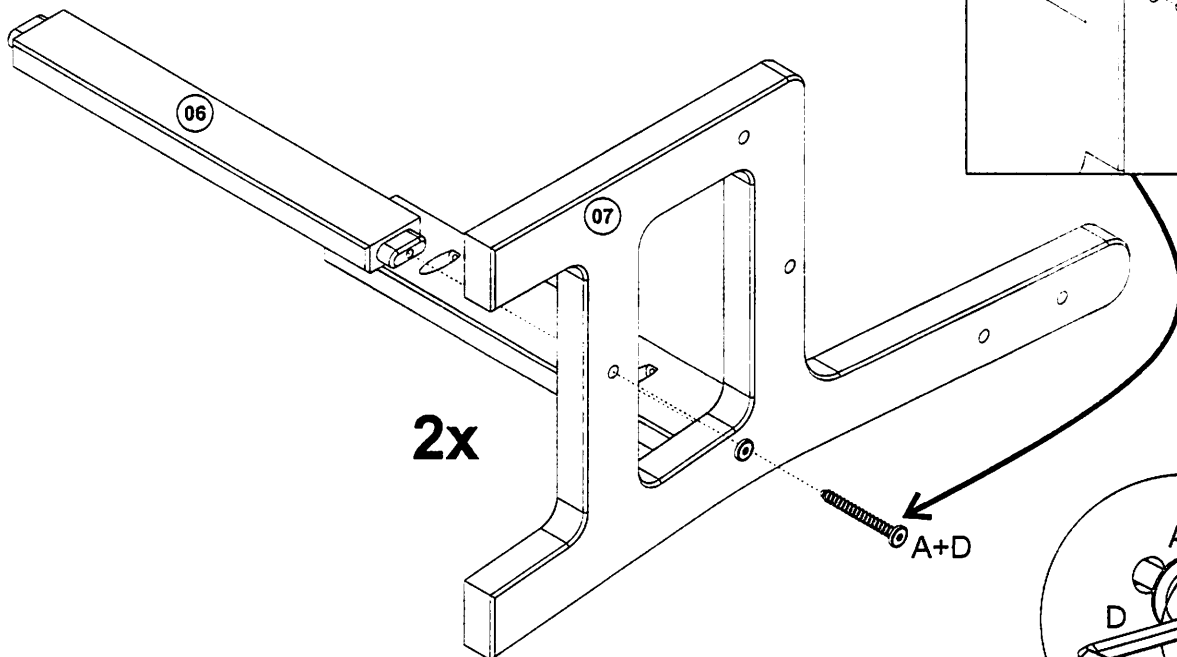
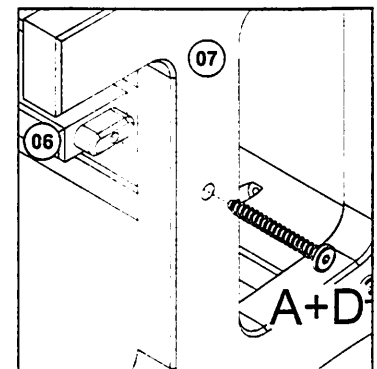

13

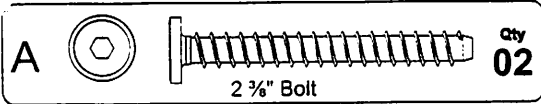
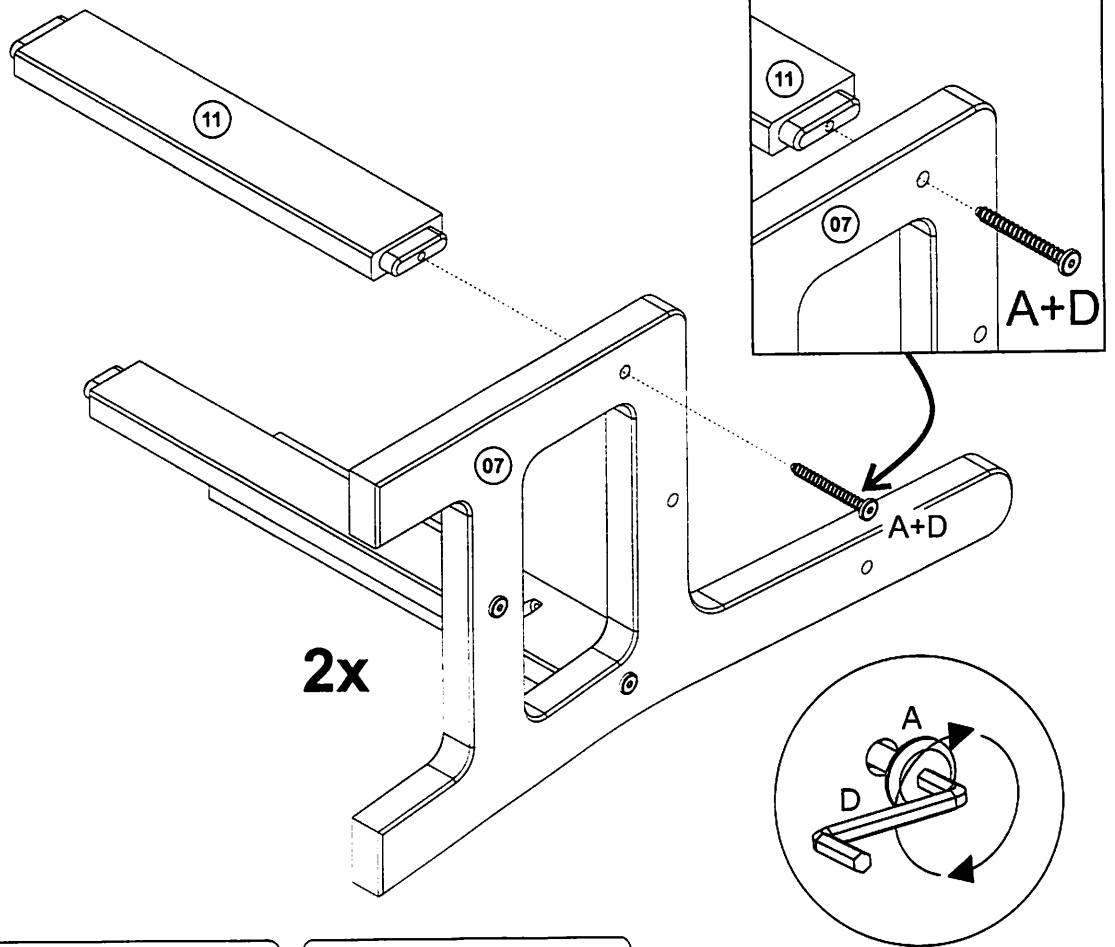

14

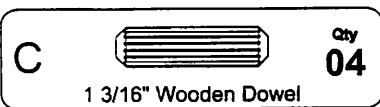
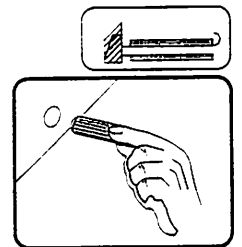
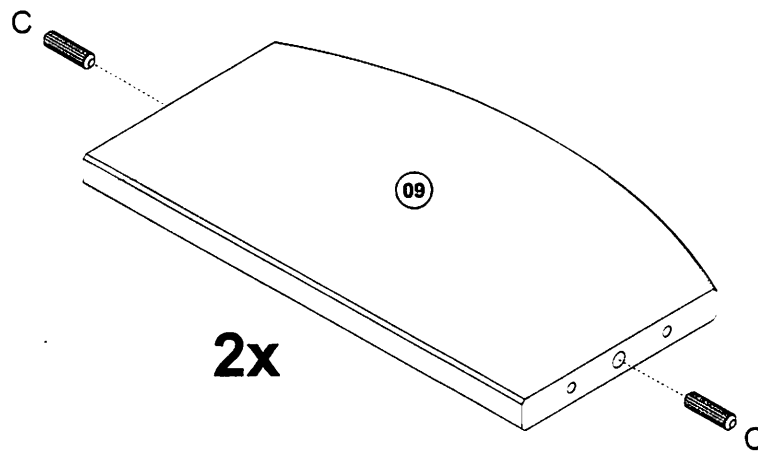

15

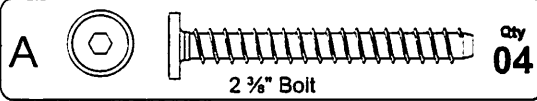
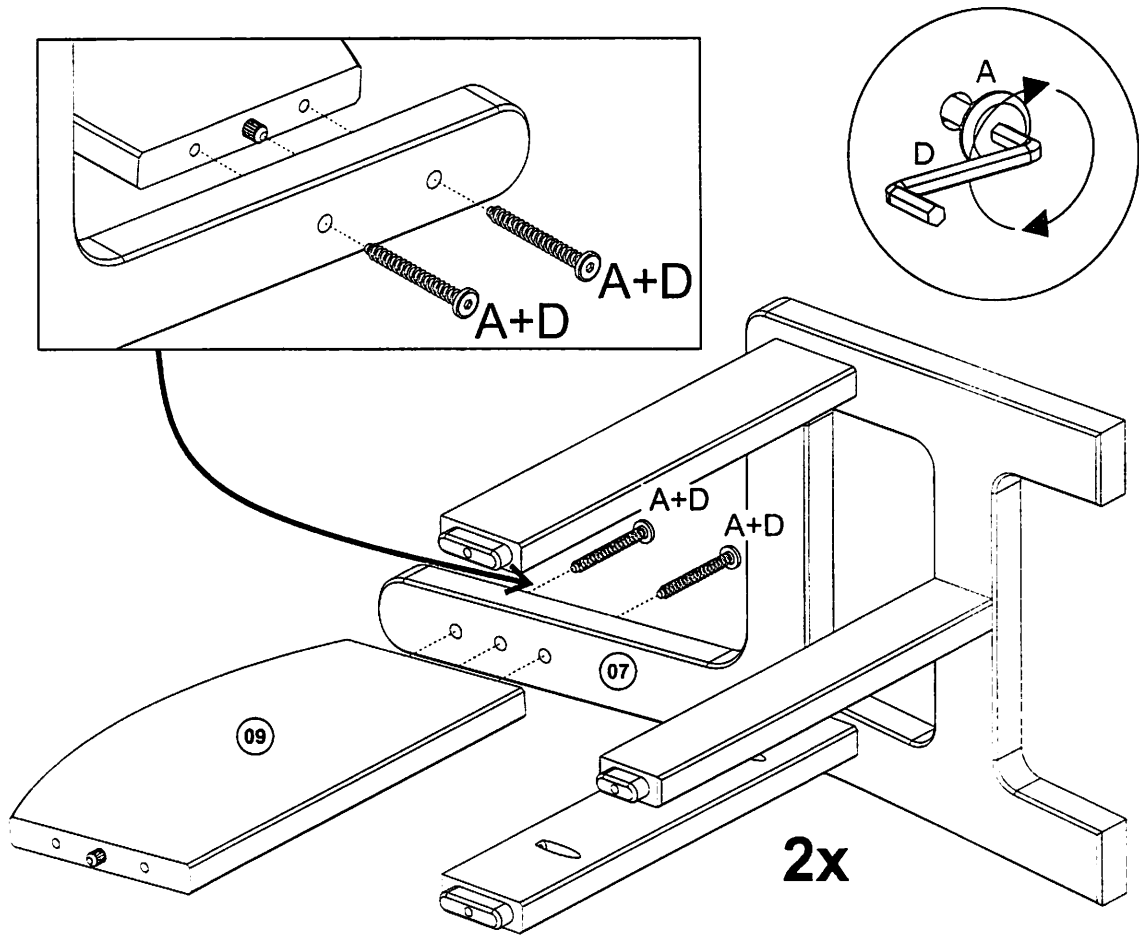

16

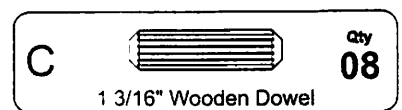
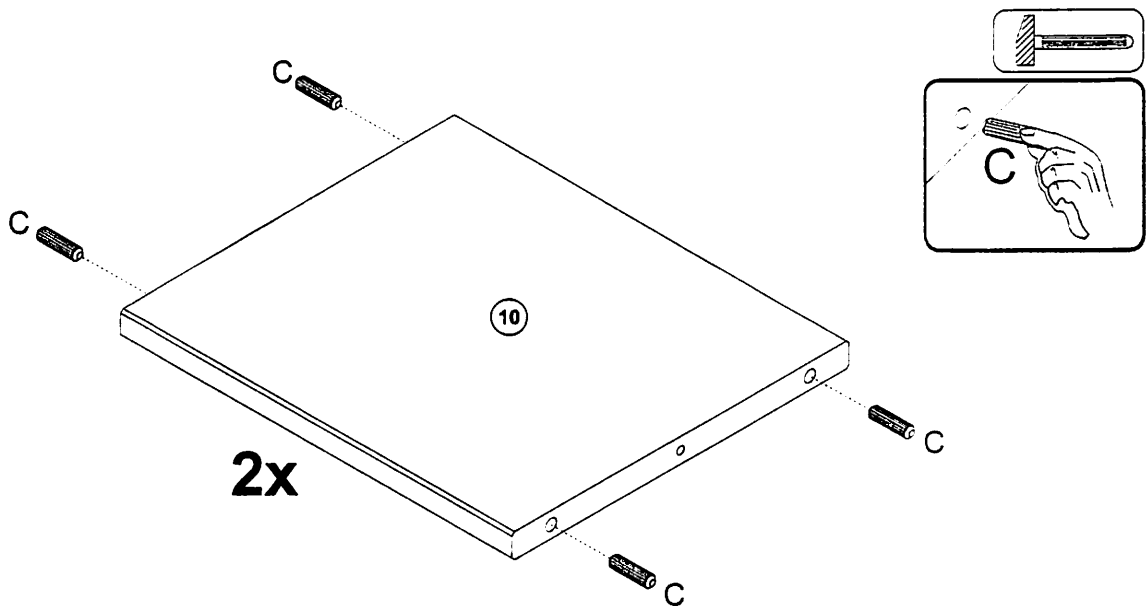

17

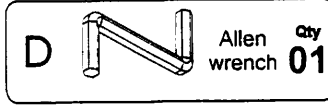
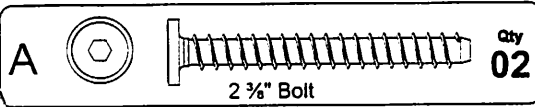
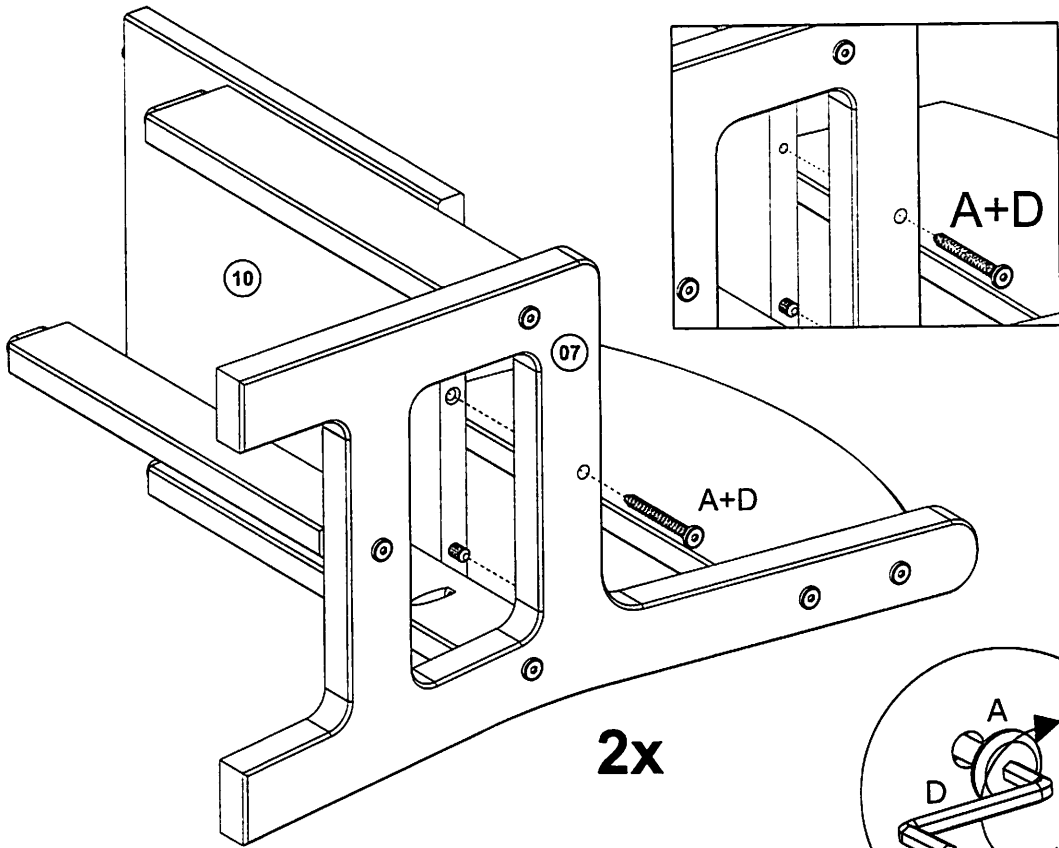

18

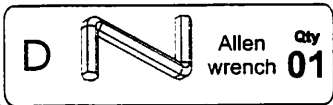
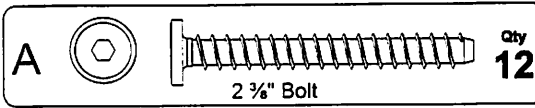
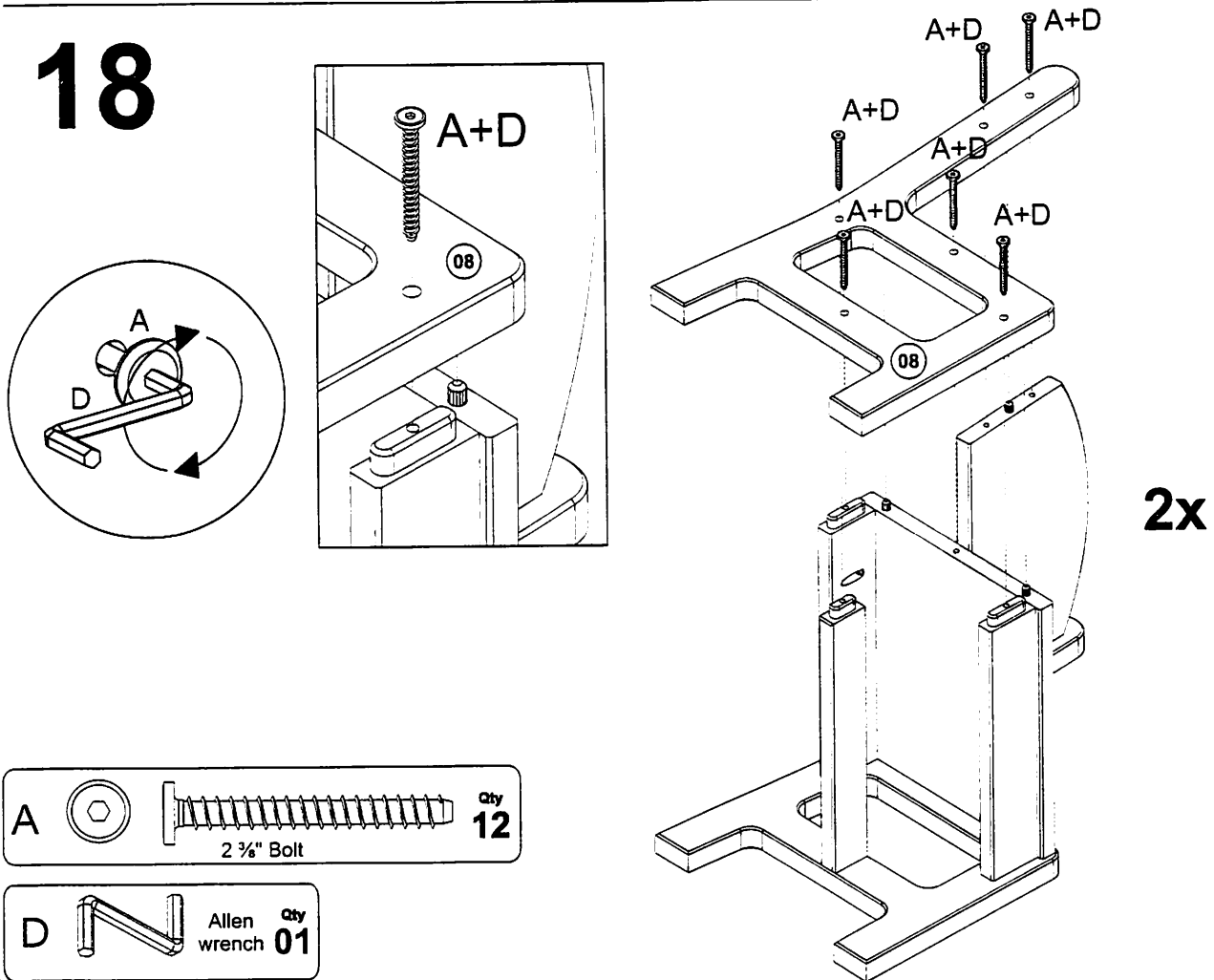

19

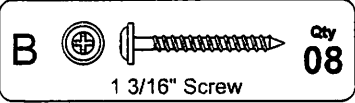
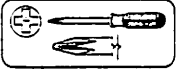
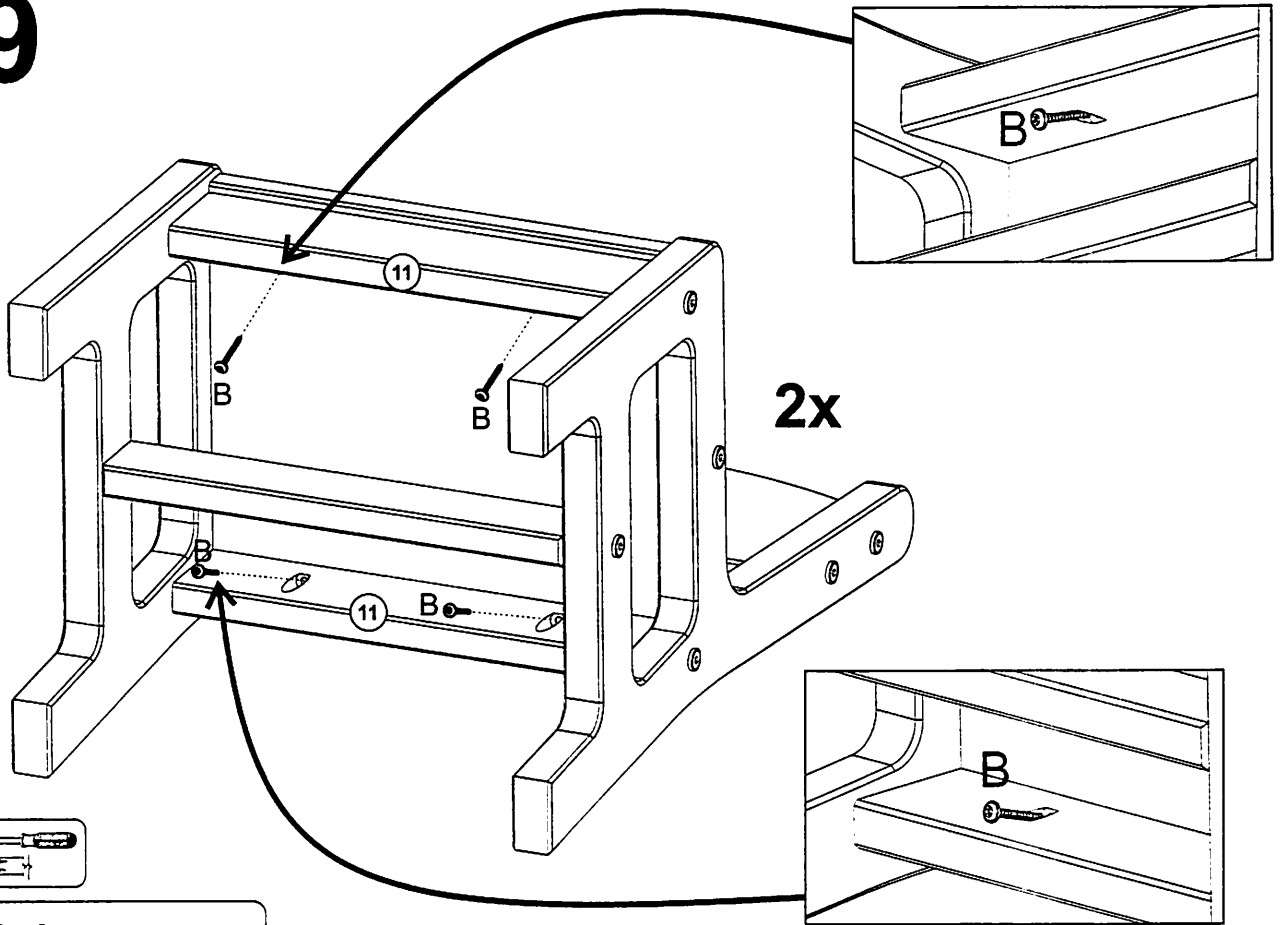

20

