



Description

The Crestron® ZUMNET-GATEWAY is a 2-way RF wireless transceiver designed for use with products that use the Zūm Net wireless communications protocol. A single ZUMNET-GATEWAY works with the ZUM-FLOOR-HUB (not included) to provide central monitoring, management, reporting, and control of lighting systems throughout the enterprise.

Additional Resources

Visit the product page on the Crestron website (www.crestron.com) for additional information. Use a QR reader application on your mobile device to scan the QR image.



Select the Mounting Location

For optimum performance when installing multiple ZUMNET-GATEWAYS near each other:

- Do not place multiple gateways on the same channel.
- Place gateways at least 15 feet (4.6 meters) apart.

For optimum performance when installing a ZUMNET-GATEWAY:

- Place gateways at least 15 feet (4.6 meters) from the nearest Wi-Fi® access point.
- Place gateways at least 6 feet (1.8 meters) from the nearest Bluetooth® device.

For more information, refer to Installation and Setup of Crestron RF Products (Doc. 6689) at www.crestron.com/manuals.

Installation

NOTE: Observe the following:

- Install and use this product in accordance with appropriate electrical codes and regulations.
- A qualified electrician must install this product.

Mount the ZUMNET-GATEWAY onto a DIN rail or onto a vertical flat surface. It can also be placed onto a horizontal flat surface.

NOTE: Do not install this gateway within 15 feet (4.6 meters) of other Zūm Net or infiNET EX® gateways.

NOTE: The ZUMNET-GATEWAY can also be rack mounted. For rack mount installation, refer to the RMK-IFE-1U Installation Guide (Doc. 7627) at www.crestron.com/manuals.

DIN Rail Mounting

1. Attach the bracket to the DIN rail by snapping it into place.
2. Attach the ZUMNET-GATEWAY to the bracket by snapping it into place.
3. Insert the supplied screws through the side of the bracket and secure the gateway.

NOTE: When mounting to a DIN rail, use the screw holes only on the side of the bracket when securing the gateway to the bracket. Using the screw holes on the back of the bracket to secure the gateway to the bracket will prevent removal of the device from the DIN rail.

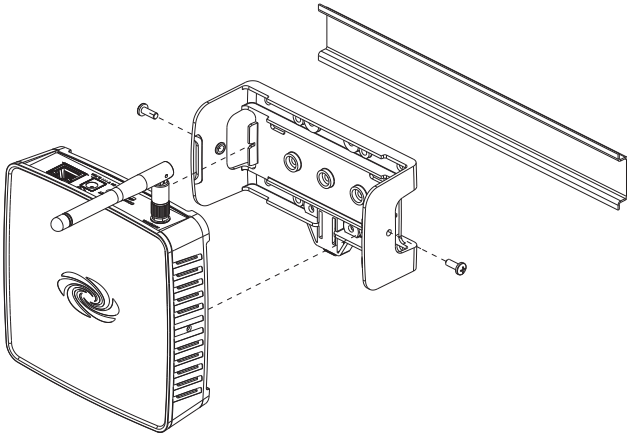

Vertical Flat Surface Mounting

1. Attach the bracket to the wall (wall mount screws not included).
2. Attach the ZUMNET-GATEWAY to the bracket by snapping it into place.
3. Insert the supplied screws through the side of the bracket and secure the gateway.

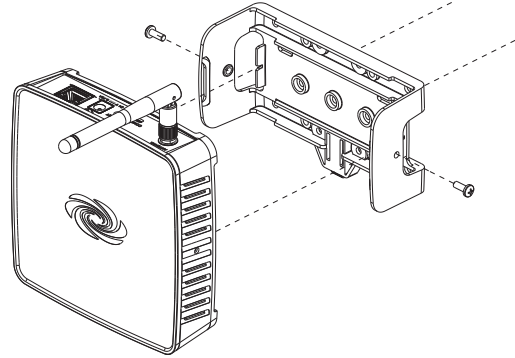

Make Connections

Make the necessary connections as called out in the illustrations that follow. Apply power after all connections have been made.

NOTE: When making connections to the ZUMNET-GATEWAY, use Crestron power supplies for Crestron equipment.

NOTE: The antenna must be attached directly to the antenna connector. It can be extended with an optional ANT-EXT-10 Antenna Extender (sold separately).

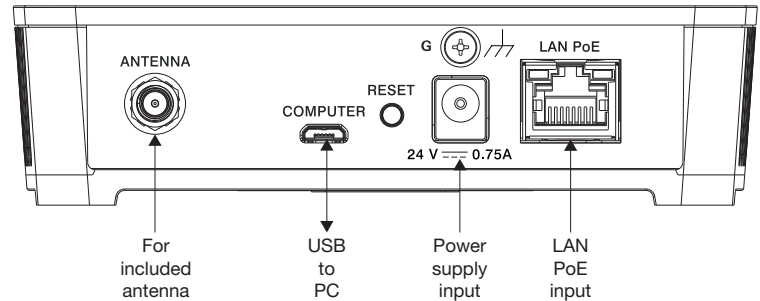

To supply power using a Crestron PoE injector (sold separately), do the following.

1. Attach the supplied ac power cord to the IEC 320 connector on the PoE (Power over Ethernet) injector.
2. Use a CAT5 cable to connect the LAN port of the PoE injector to the LAN.
3. Use a CAT5 cable to connect the LAN POE port of the PoE injector to the LAN PoE input port of the ZUMNET-GATEWAY.
4. Insert the other end of the power cord into an active ac outlet.

NOTE: In the listing of LAN PoE and LAN pins in the following image, arrows denote internal pin connections.

LAN PoE and LAN Pin Assignments

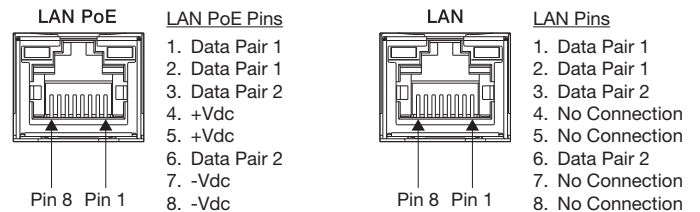

Specifications

SPECIFICATION	DETAILS
Supported Devices Zūm Net Devices Maximum Devices Allowed	Supports Crestron Zūm Net wireless devices only Supports up to 100 Zūm Network Bridges per Zūm Net Gateway
Wireless Communications RF Transceiver Range	Zūm Net 2-way RF, 2.4 GHz ISM Channels 11-26 (2400 to 2483.5 MHz), default channel 15, IEEE 802.15.4 compliant 50 ft (15 m) to nearest Zūm Net mesh network device(s), subject to site-specific conditions and individual device capabilities, range between floors or ceilings is limited to one level
Wired Communications Ethernet USB	10/100 Mbps, auto-switching, auto-negotiating, auto-discovery, full/half duplex, DHCP, IEEE 802.3at Type 1 compliant USB device port for setup
Power Power over Ethernet (PoE) Power Pack Power Consumption	IEEE 802.3at Type 1 (802.3af compatible) Class 1 (3.84 W) PoE powered device; Maximum distance is 100 meters (328 feet) 0.75 A (minimum) @ 24 VDC; 100-240 VAC, 50/60 Hz power pack, model PW-2407WU not included 2.1 watts typical
Environmental Temperature Humidity Heat Dissipation	41° to 104 °F (5° to 40 °C) 10% to 90% RH (non-condensing) 7 Btu/h
Construction Enclosure Mounting	IFE small form factor, black and blue plastic Freestanding, surface mount, or 35 mm DIN EN 60715 rail mount; Occupies 8 DIN module spaces (144 mm); Surface/DIN rail mounting bracket included, optional rack mount and pole mount kits not included

NOTE: “Zūm Net” refers to the wireless mesh network that connects one or more rooms with a Zūm Floor Hub, and consists of one Zūm Net Wireless Gateway and one or more Zūm Network Bridges. Each Zūm Network Bridge functions as a routing node, which relays the signals it receives on to any other Zūm Net devices within range. This effectively extends the total range of the network and provides multiple redundant signal paths for extra reliability. A maximum of six “hops” across routing nodes is allowed, although a maximum of three is recommended. Up to 100 Zūm Net devices are permitted per gateway, although best practices suggest a limit of 50. Refer to the “Installation and Setup of Crestron RF Products” Best Practices guide (Doc. 6689) at www.crestron.com/manuals for more information.

NOTE: Do not stack multiple gateways.

This product is Listed to applicable UL® Standards and requirements by Underwriters Laboratories Inc.



Federal Communications Commission (FCC) Compliance Statement

This device complies with part 15 of the FCC Rules. Operation is subject to the following conditions:

(1) This device may not cause harmful interference and (2) this device must accept any interference received, including interference that may cause undesired operation.

CAUTION: Changes or modifications not expressly approved by the manufacturer responsible for compliance could void the user's authority to operate the equipment.

NOTE: This equipment has been tested and found to comply with the limits for a Class B digital device, pursuant to part 15 of the FCC Rules. These limits are designed to provide reasonable protection against harmful interference in a residential installation. This equipment generates, uses, and can radiate radio frequency energy and, if not installed and used in accordance with the instructions, may cause harmful interference to radio communications. However, there is no guarantee that interference will not occur in a particular installation.

If this equipment does cause harmful interference to radio or television reception, which can be determined by turning the equipment off and on, the user is encouraged to try to correct the interference by one or more of the following measures:

- Reorient or relocate the receiving antenna.
- Increase the separation between the equipment and receiver.
- Connect the equipment into an outlet on a circuit different from that to which the receiver is connected.
- Consult the dealer or an experienced radio/TV technician for help.

Industry Canada (IC) Compliance Statement

This device complies with Industry Canada license-exempt RSS standard(s). Operation is subject to the following two conditions: (1) this device may not cause interference and (2) this device must accept any interference, including interference that may cause undesired operation of the device radio interference to other users, the antenna type and its gain should be so chosen that the equivalent isotropically radiated power (e.i.r.p.) is not more than that necessary for successful communication.

Industrie Canada (IC) Déclaration de conformité

Le présent appareil est conforme aux CNR d'Industrie Canada applicables aux appareils radio

exempts de licence. L'exploitation est autorisée aux deux conditions suivantes : (1) l'appareil ne doit pas produire de brouillage, et (2) l'utilisateur de l'appareil doit accepter tout brouillage radioélectrique subi, même si le brouillage est susceptible d'en compromettre le fonctionnement.

Conformément à la réglementation d'Industrie Canada, le présent émetteur radio peut fonctionner avec une antenne d'un type et d'un gain maximal (ou inférieur) approuvé pour l'émetteur par Industrie Canada. Dans le but de réduire les risques de brouillage radioélectrique à l'intention des autres utilisateurs, il faut choisir le type d'antenne et son gain de sorte que la puissance isotrope rayonnée équivalente (p.i.r.e.) ne dépasse pas l'intensité nécessaire à l'établissement d'une communication satisfaisante.

To satisfy RF exposure requirements, this device and its antenna must operate with a separation distance of at least 20 centimeters from all persons and must not be colocated in conjunction with any other antenna or transmitter.

The product warranty can be found at www.crestron.com/warranty.

The specific patents that cover Crestron products are listed at www.crestron.com/legal/patents.

Certain Crestron products contain open source software. For specific information, please visit www.crestron.com/opensource.

Crestron, the Crestron logo, infINET EX, and Zūm are either trademarks or registered trademarks of Crestron Electronics, Inc. in the United States and/or other countries. Bluetooth is either a trademark or registered trademark of Bluetooth SIG, Inc. in the United States and/or other countries. UL and the UL logo are either trademarks or registered trademarks of Underwriters Laboratories, Inc. in the United States and/or other countries. Wi-Fi is either a trademark or registered trademark of Wi-Fi Alliance in the United States and/or other countries. Other trademarks, registered trademarks, and trade names may be used in this document to refer to either the entities claiming the marks and names or their products. Crestron disclaims any proprietary interest in the marks and names of others. Crestron is not responsible for errors in typography or photography.

This document was written by the Technical Publications department at Crestron.

©2018 Crestron Electronics, Inc.

Crestron Electronics, Inc.
15 Volvo Drive, Rockleigh, NJ 07647
Tel: 888.CRESTRON
Fax: 201.767.7576
www.crestron.com

Installation Guide - DOC. 7936C
(2048522)
06.18

Specifications subject to
change without notice.