

Key Features

- **No water filtration required**
- **Produces up to 65 lb of ice per day**
- Bright white LED lighting
- Built-in or freestanding
- Digital touch pad control
- Easy 20 minute clean cycle
- Factory installed drain pump
- Field reversible door is shipped right-hand hinged
- Four adjustable leveling legs
- Indicator alert notifies user if water issues are detected
- Makes compressed ice bits approx. 1/2" L x 3/8" H
- Stainless steel cabinet, toe-kick, and full-wrap door
- Stainless steel handle (7/8" diameter)
- Stores 27 lb of ice
- UV light activated when door is closed
- White interior

Model Details

Model	Voltage/Hz	Door Swing	Pump	Finish	Shipping Weight
UONP115-SS01C	115 / 60	Field Reversible	Pump Included	Stainless Solid	105 lb

Accessories

Model	Description	Finish	Shipping Weight
80-55667-00	Ice Machine Cleaner (Single 8 oz. bottle)	N/A	1 lb
ULAWATERHOOKUP	Braided Water Supply Line Kit	N/A	2 lb

Front

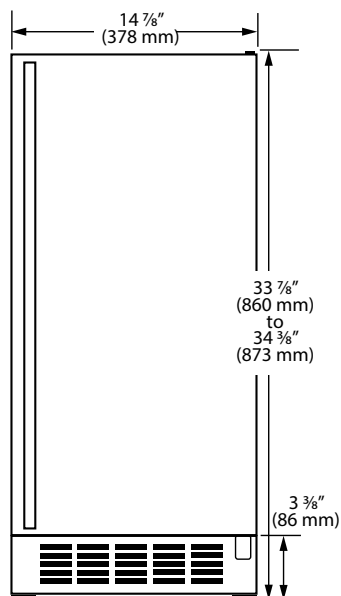

Side

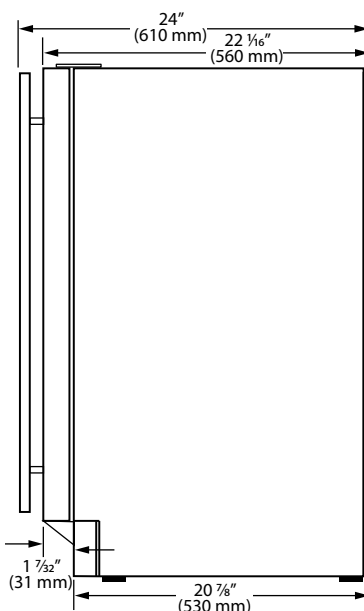

Top

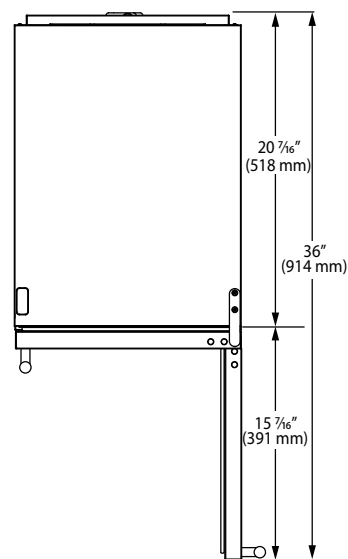

Specifications

Model	ONP115
Amps: Running	3
Dimensions: Product Depth	22 1/16" / 560 mm
Dimensions: Product Height	33 7/8" / 860 mm
Dimensions: Product Width	14 7/8" / 378 mm
ENERGY STAR	Yes
Ice Production Per Day	65 lb
Ice Storage	27 lb
Product Weight: Max	104 lb
Refrigerant Type:	R600a (1.59 oz)

Back

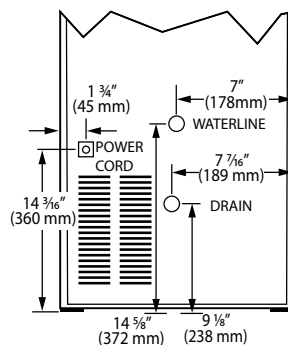

Cabinet Cut-Out

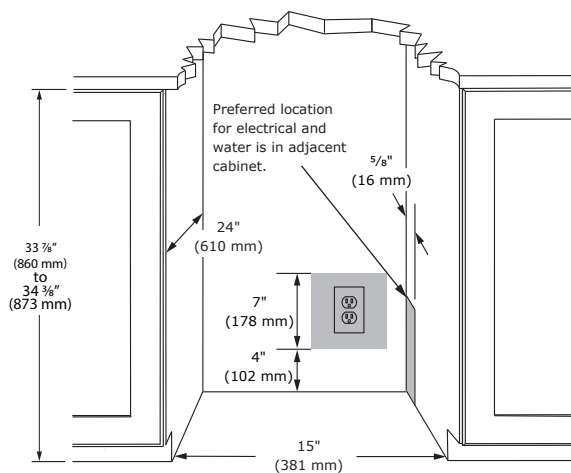

Installation Notes

- No additional clearance is needed for ventilation
- Do not obstruct front grille air flow

Warranty

- **2024 Nugget Ice Bonus Warranty – 2 years (parts and labor) / 5 years (sealed system)**
- See complete warranty for details

