

ASSEMBLY INSTRUCTIONS
COASTER FINE FURNITURE

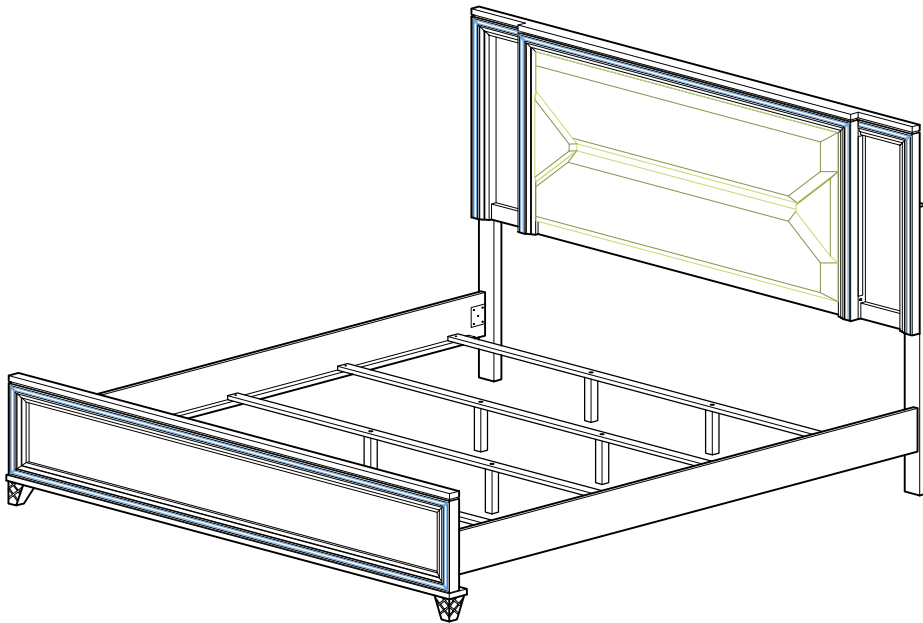

Fine Furniture for every stage of life

224961KE (B1-B3)
Eastern King Bed

ITEM: 224961KE (B1-B3)



ASSEMBLY INSTRUCTIONS

ASSEMBLY TIPS:

1. Remove hardware from box and sort by size.
2. Please check to see that all hardware and parts are present prior to start of assembly.
3. Please follow attached instructions in the same sequence as numbered to assure fast & easy assembly.



WARNING!

1. Don't attempt to repair or modify parts that are broken or defective. Please contact the store immediately.
2. This product is for home use only and not intended for commercial establishments.

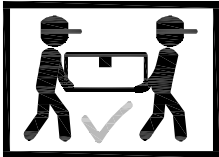

ASSEMBLY TIME

30 MINUTES

PARTS IDENTIFICATION

B1 (BOX 1)

A HEADBOARD PANEL

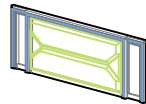

1PC

B LEFT HEADBOARD LEG



1PC

C RIGHT HEADBOARD LEG



1PC

D ADAPTER



1PC

B2 (BOX 2)

E FOOTBOARD PANEL

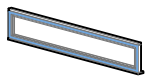

1PC

F FOOTBOARD FOOT



2PCS

G BED SLAT



4PCS

H BED SLAT SUPPORT



8PCS

B3 (BOX 3)

I BED RAIL



2PCS

HB
224961KE(B1)
FROM BOX 1
HEADBOARD
COMPLETE

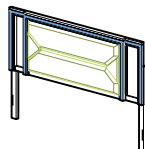

1PC

FB
224961KE(B2)
FROM BOX 2
FOOTBOARD
COMPLETE

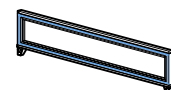

1PC

ITEM: 224961KE (B1-B3)



ASSEMBLY INSTRUCTIONS

ASSEMBLY TIPS:

1. Remove hardware from box and sort by size.
2. Please check to see that all hardware and parts are present prior to start of assembly.
3. Please follow attached instructions in the same sequence as numbered to assure fast & easy assembly.







WARNING!





1. Don't attempt to repair or modify parts that are broken or defective. Please contact the store immediately.
2. This product is for home use only and not intended for commercial establishments.

HARDWARE IDENTIFICATION

Z-B1 (BOX 1) - HARDWARE PACK IS LOCATED IN 224961KE (B1)

1	BOLT (M6 x 40mm - RBW)		6PCS
2	LOCK WASHER (M6 x 12mm - RBW)		6PCS
3	FLAT WASHER (M6 x 13mm - RBW)		6PCS
4	ALLEN WRENCH (M4 x 60mm - BLK)		1PC

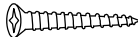
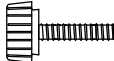
Z-B2 (BOX 2) - HARDWARE PACK IS LOCATED IN 224961KE (B2)

5	BOLT (M6 x 35mm - RBW)		8PCS
6	LOCK WASHER (M6 x 12mm - RBW)		8PCS
7	FLAT HEAD SCREW (M3.5 x 32mm - RBW)		8PCS
8	ADJUSTABLE LEVELER (M6 x 39mm)		8PCS
9	ALLEN WRENCH (M4 x 60mm - BLK)		1PC

NOTE:

Phillips head screw driver is required in the assembly process; however, manufacturer does not provide this item.

ITEM: 224961KE (B1-B3)

ASSEMBLY INSTRUCTIONS



STEP 1

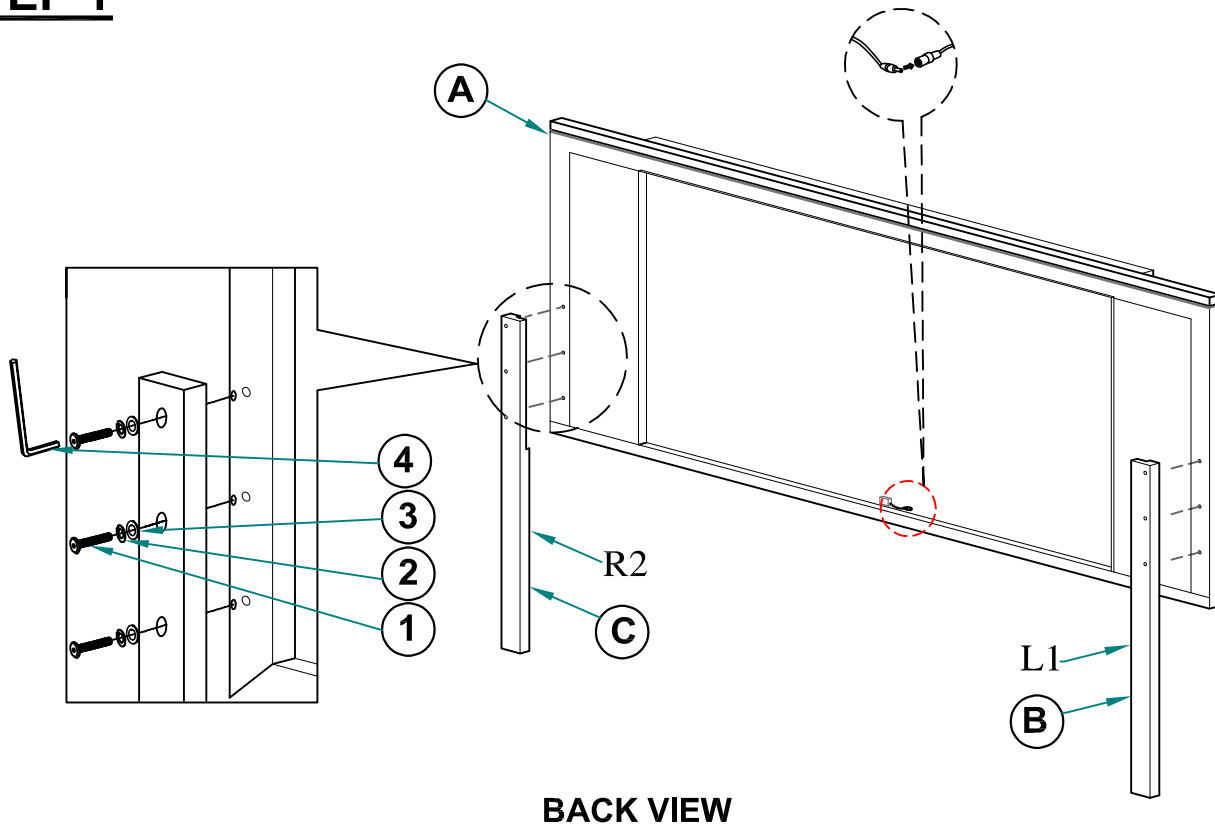

BACK VIEW

STEP 2

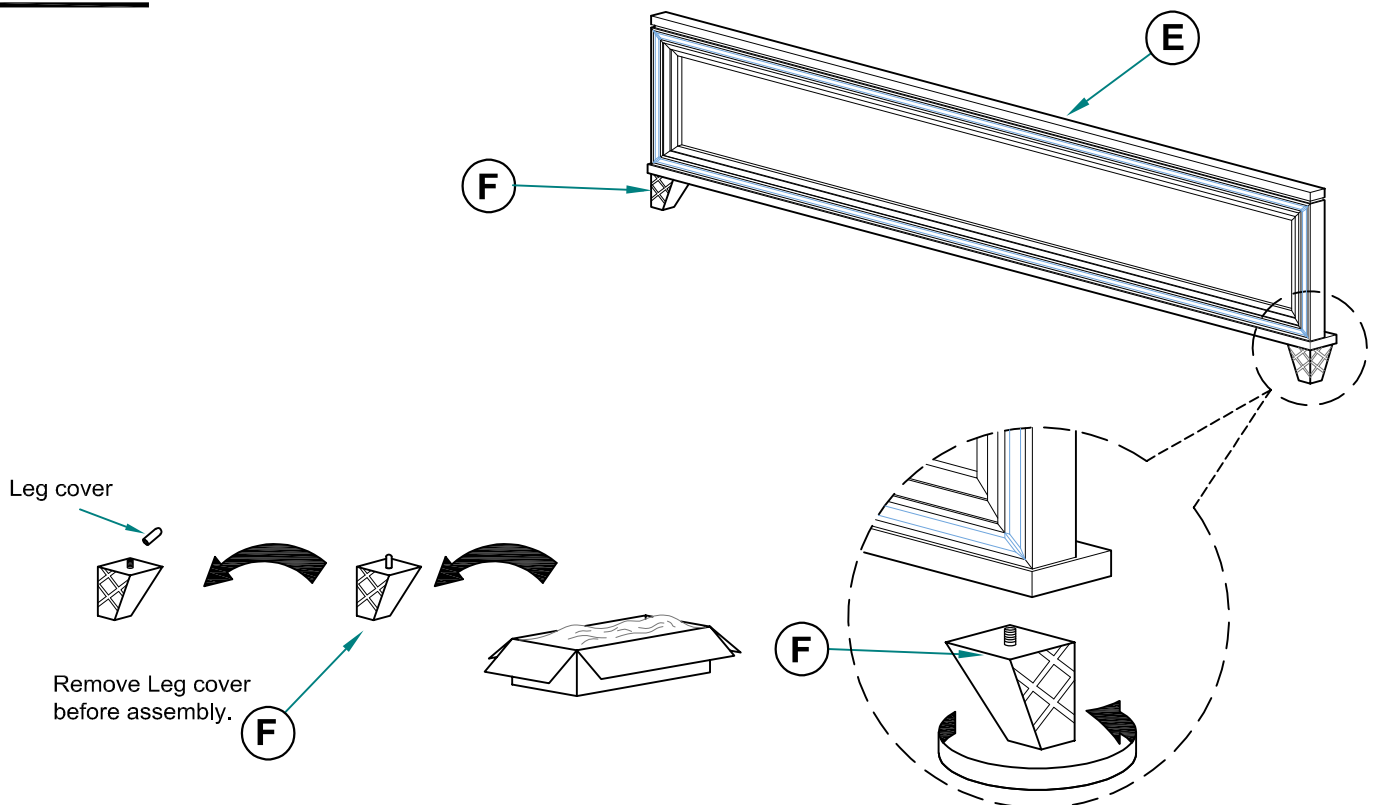

ITEM: 224961KE (B1-B3)

ASSEMBLY INSTRUCTIONS



STEP 3

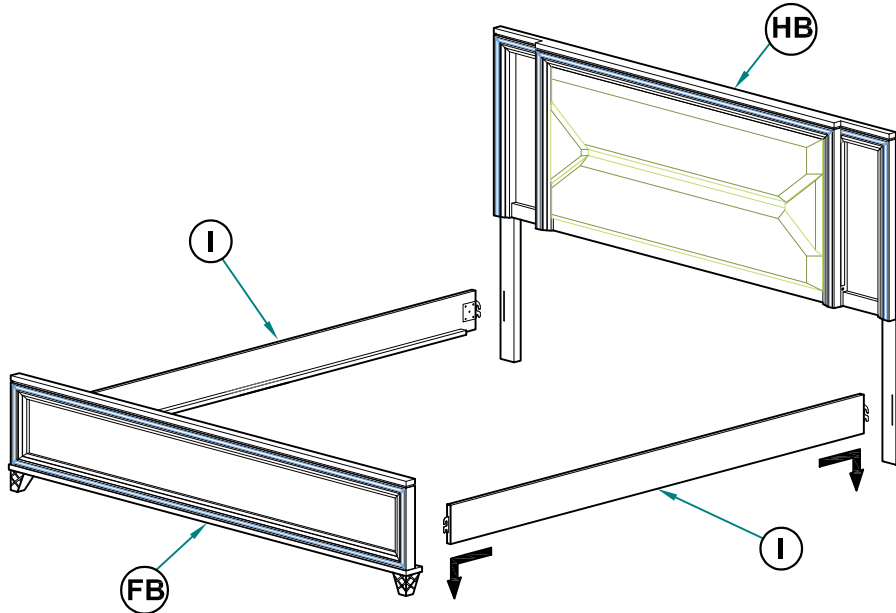

STEP 4

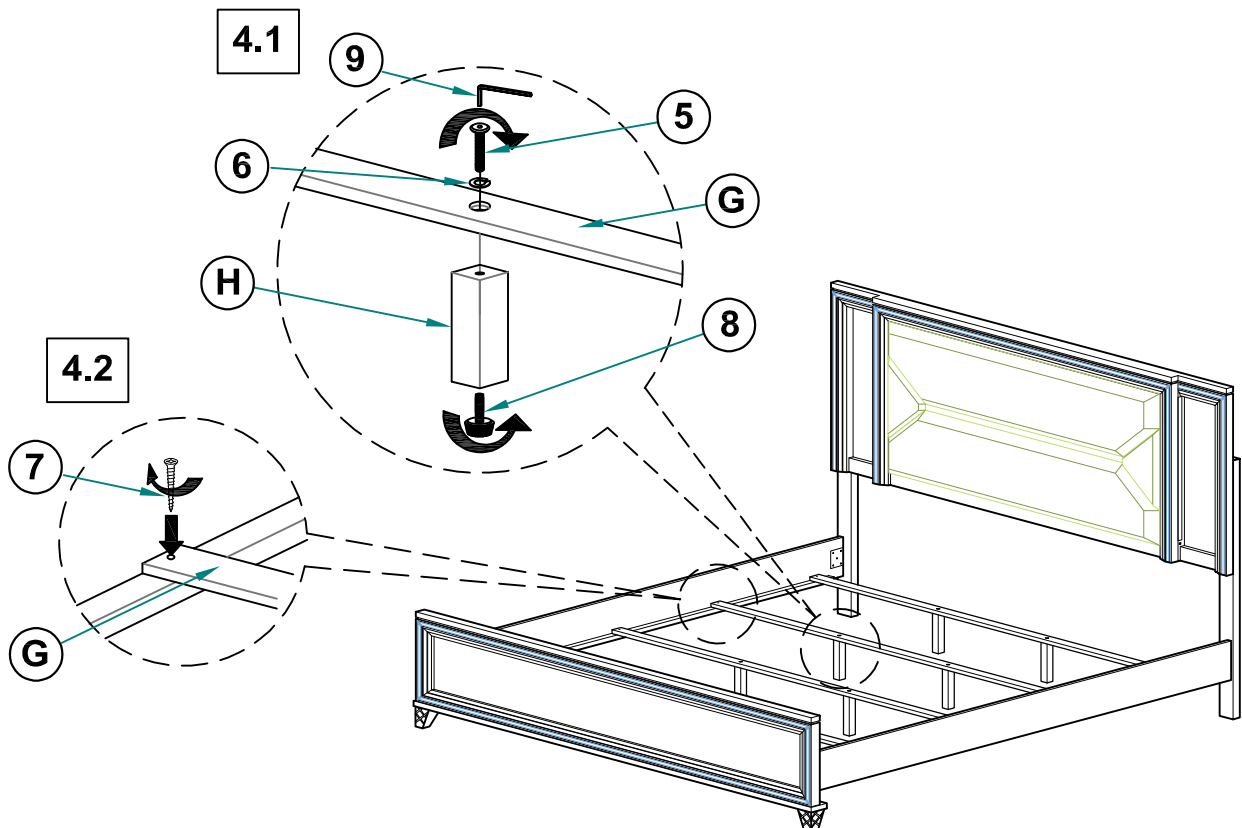

ITEM: **224961KE (B1-B3)**

ASSEMBLY INSTRUCTIONS



STEP 5
COMPLETE

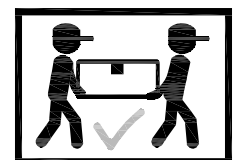
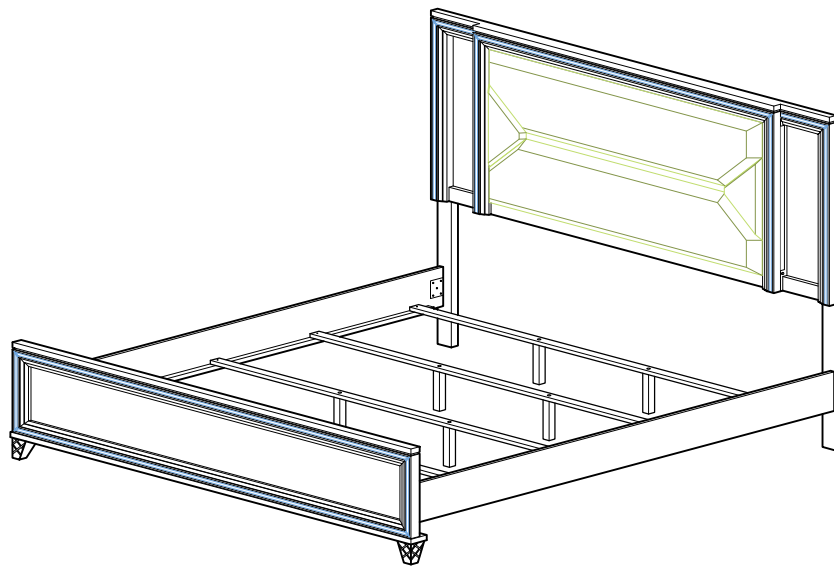

ITEM: **224961KE (B1-B3)**



Inner Size : 76.50"W x 80.25"D

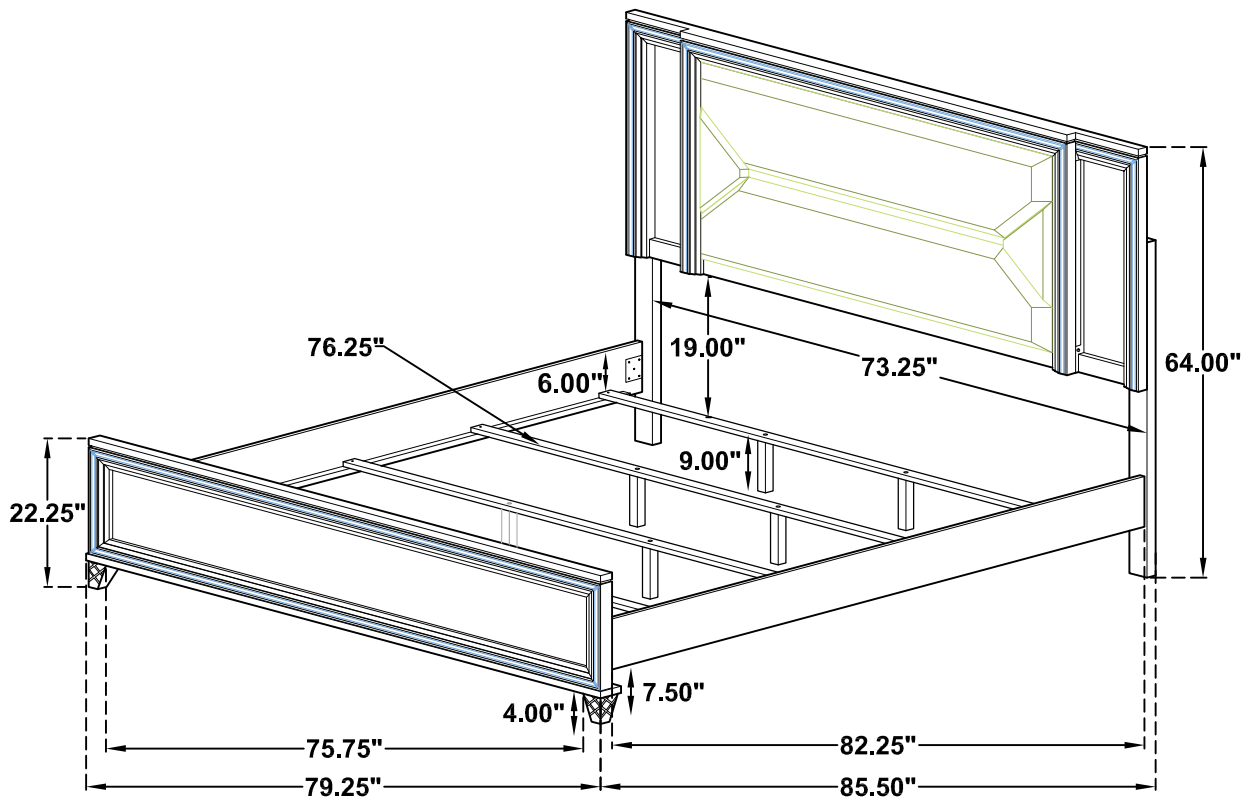

Note : Dimension tolerance $\pm 5\%$