

**Furniture of America®**

# Assembly Instructions

CM7733F/CM7733Q/CM7733CK/CM7733EK

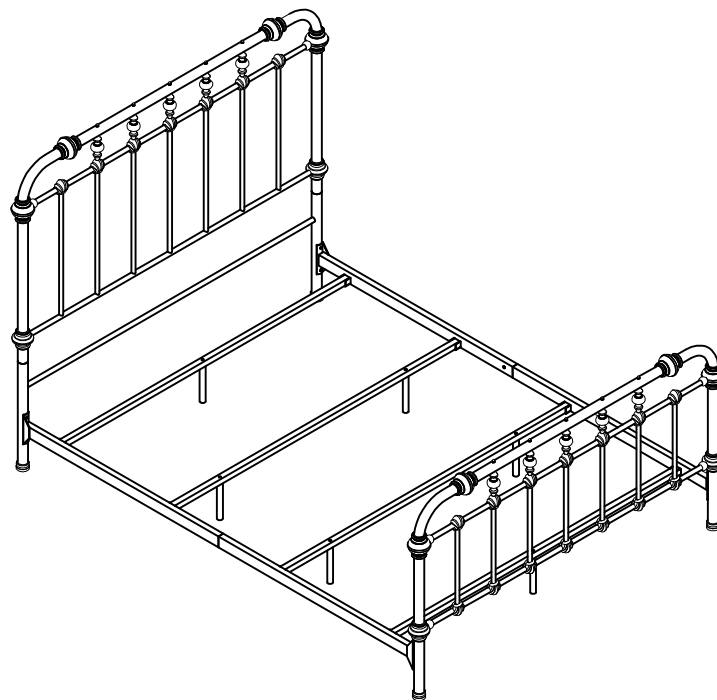

## ASSEMBLY RATING

The Assembly Rating is a 5-point system that shows the degree of effort needed in assembling a specific product (with 1 being easy and 5 being difficult). For some products, two persons are recommended.

## Tools Required For Assembly:

Allen Wrench

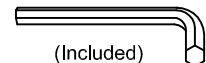

(Included)

Wrench

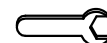

(Included)

EASY



DIFFICULT



2 PERSONS RECOMMENDED

# ASSEMBLY & CARE ADVICE

FOR YOUR FURNITURE TO LAST, CORRECT ASSEMBLY AND PROPER MAINTENANCE ARE NECESSARY. PLEASE FOLLOW THE INFORMATION PROVIDED BELOW TO FULLY ENJOY YOUR FURNITURE.

## BASIC ASSEMBLY TECHNIQUES

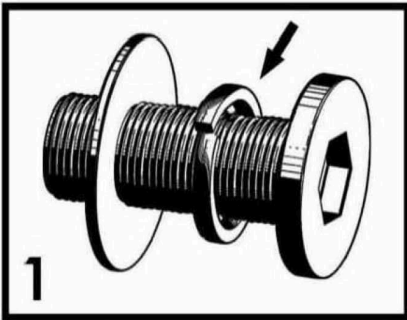

When lock or spring washer is used in an assembly, please make sure the lock or spring washer is placed between the larger flat washer and the head of the screw or bolt.

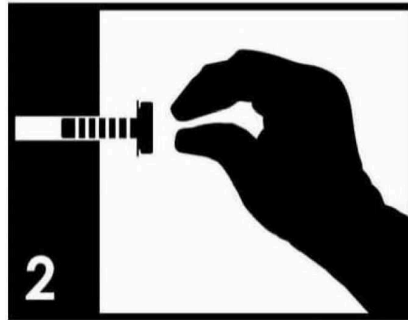

Position each part correctly and insert screws or bolts into their respective holes by hand tighten or using the proper hand tool. Only tighten when step is completed or when instructed to do so.

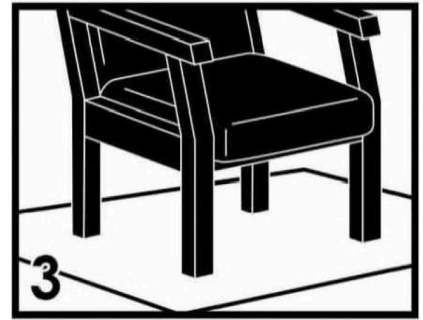

Use cardboard or carpet area when assembling furniture to prevent scratches. Make sure the furniture rests on a flat and level surface with each leg evenly touching the floor.

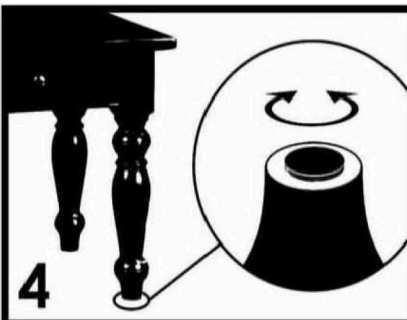

Some furniture comes with height adjustment knobs underneath each leg. To lower or to raise each leg, you need to turn clockwise or counterclockwise, respectively.

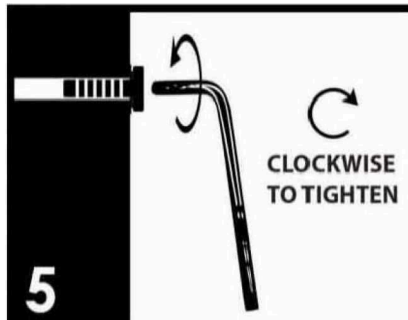

Make sure all parts are properly aligned, then use the appropriate hand tool to completely tighten the bolts or screws. Do not use power tools and do not overtighten.

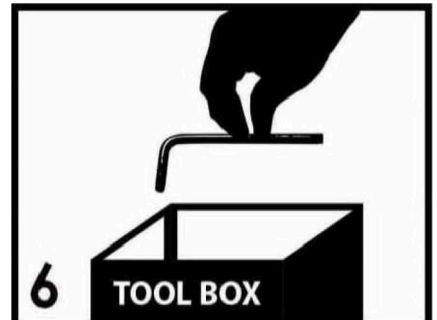

Save the instructions and store the Allen wrench or any supplied tool for later maintenance. After two weeks, check and tighten any loose hardware and repeat again every six months thereafter.

IT IS THE USER'S RESPONSIBILITY TO MAINTAIN THE FURNITURE. THE HARDWARE MAY LOOSEN OVER TIME AND MAY CAUSE THE FURNITURE TO BE WOBBLY AND UNABLE TO SUPPORT ITS INTENDED WEIGHT CAPACITY. THIS MAY LEAD TO COLLAPSE AND MAY CAUSE SERIOUS INJURY.

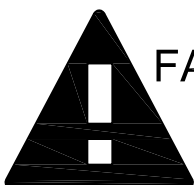

**FAILURE TO FOLLOW THE GUIDELINES ABOVE MAY RESULT IN INJURY AND/OR PROPERTY DAMAGE.**

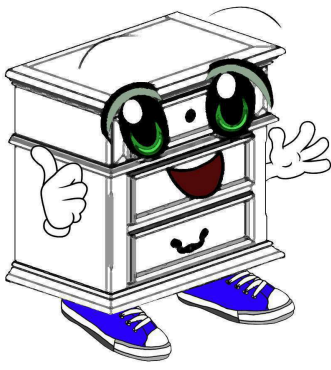

Before you begin, please read Page 2 of "Assembly and Care Advice".

And remember, do not tighten until each step is completed or instructed.

### Parts List



#1 x 1pc  
Headboard



#2 x 1pc  
Footboard

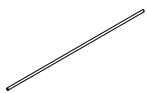

#3 x 1pc  
Cross Bar



#4 x 2pcs  
Headboard Leg

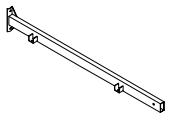

#5 x 2pcs  
Side Rail 1

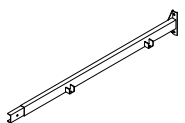

#6 x 2pcs  
Side Rail 2

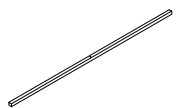

#7 x 2pcs  
Slat 1

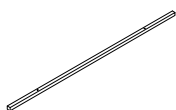

#8 x 2pcs  
Slat 2



#9 x 6pcs  
Support Leg

### Hardware List



#A x 16pcs  
Bolt 1/4"x 5/8"



#B x 4pcs  
Bolt 1/4"x 3/4"



#C x 6pcs  
Bolt 1/4"x1-3/4"



#D x 6pcs  
Bolt 1/4"x 2-1/4"



#E x 30pcs  
Flat Washer  $\phi$ 16mm



#F x 4pcs  
Hex Nut 1/4"

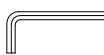

#G x 1pc  
Allen Wrench M4

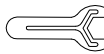

#H x 1pc  
Wrench



### ASSEMBLY

Do not fully tighten all bolts until assembly is complete. This will help all parts to assemble properly.

#A  2pcs

#E  2pcs

#G 

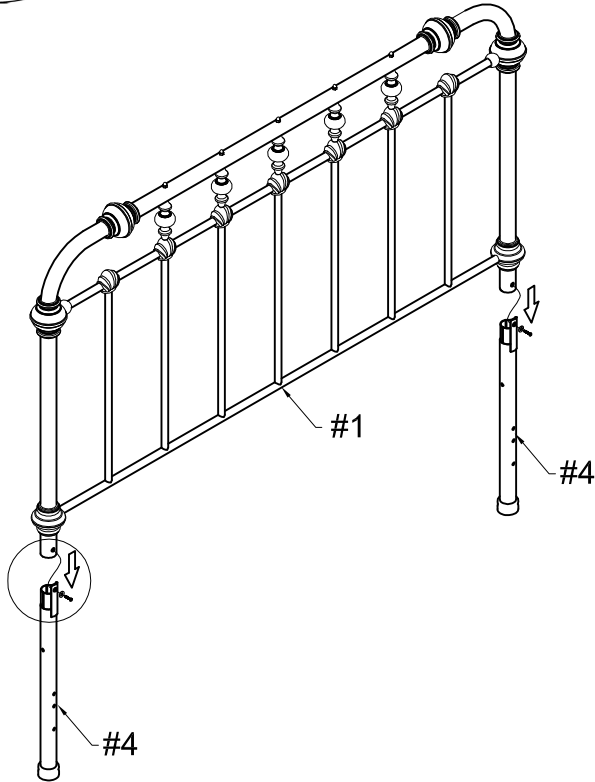

Insert each end of the headboard (#1) into the headboard legs (#4), then insert a bolt (#A) with flat washer (#E) into each hole. Secure using the Allen wrench (#G).

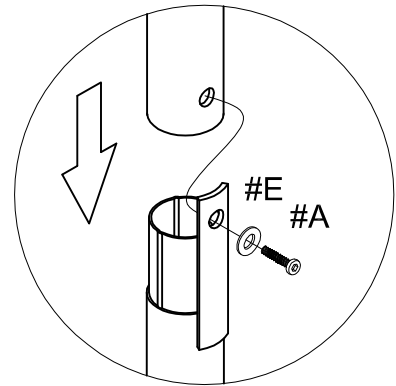

#D  2pcs

#G 

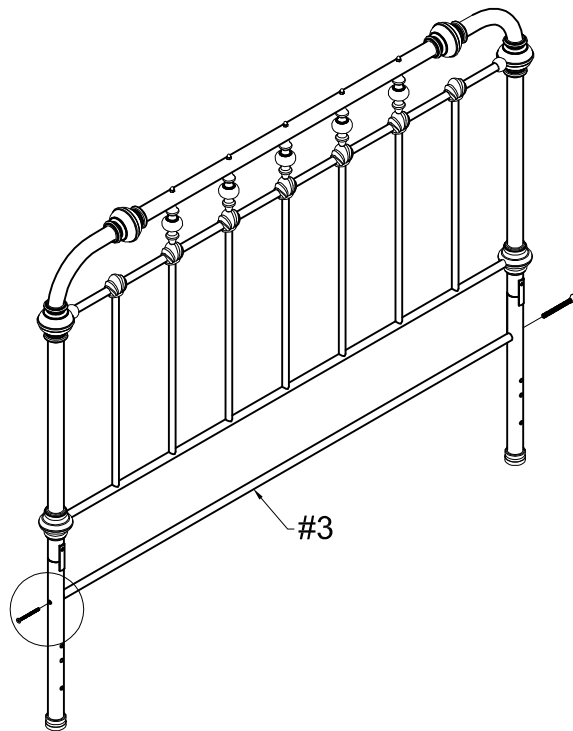

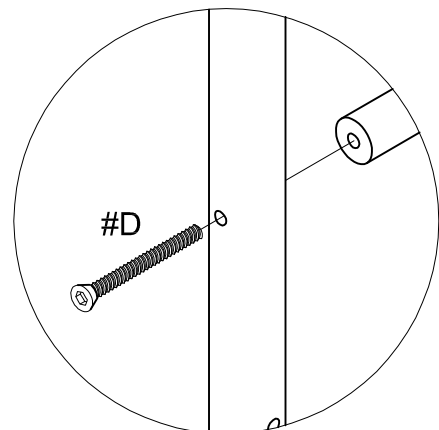

Align each end of the cross bar (#3) to the holes along the headboard legs (#4). Insert a bolt (#D) into each end and secure.







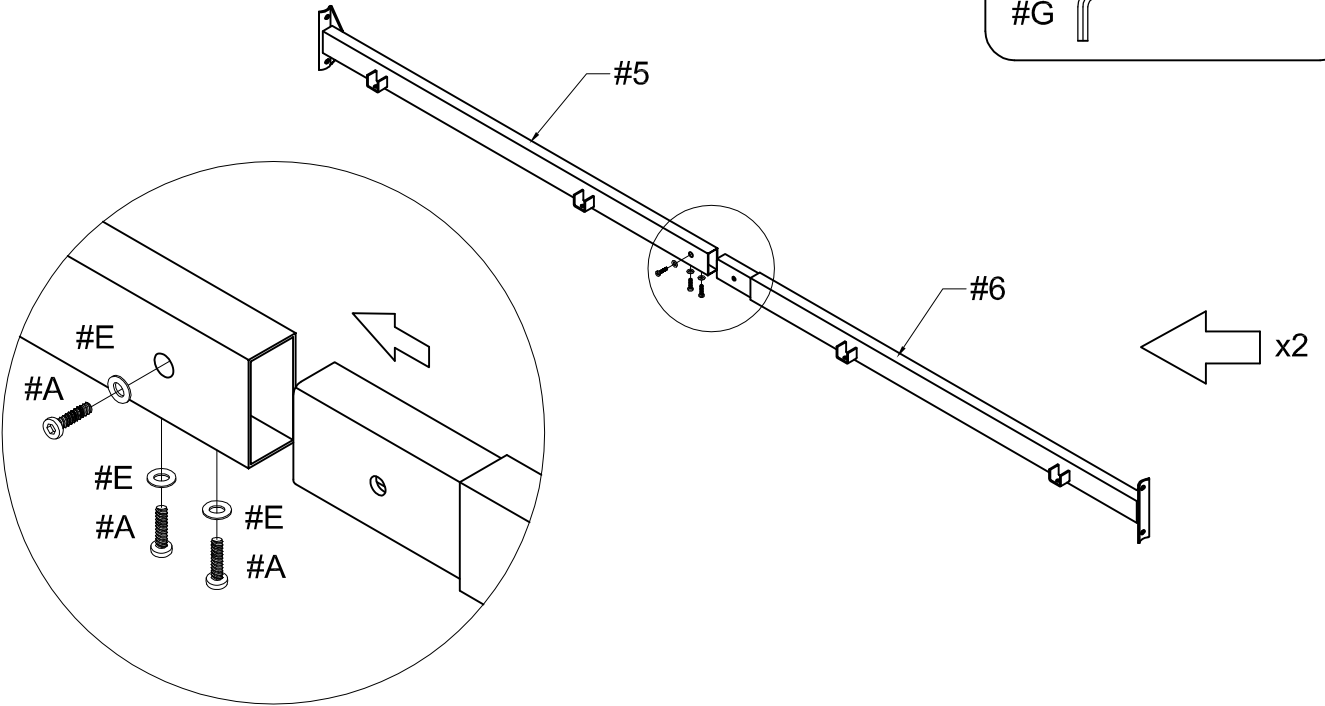

Insert the side rails (#6) into the side rails (#5), then insert the bolts (#A) with flat washers (#E) into each hole. Secure using the Allen wrench (#G).

- #A  6pcs
- #E  6pcs
- #G 

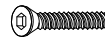

Align the side rail ends to the headboard (#1), then insert the bolts (#D) into the outer holes.

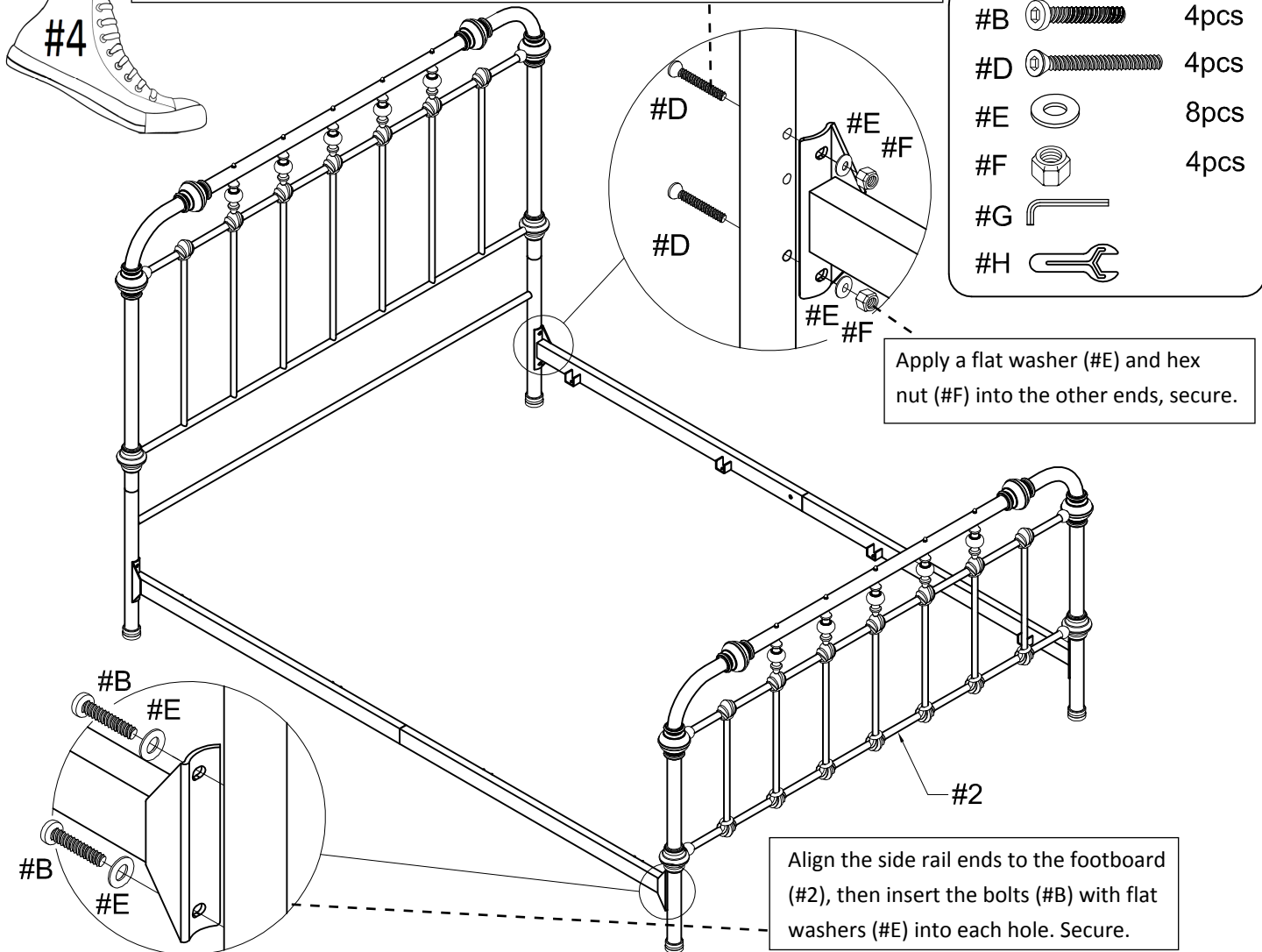

- #B  4pcs
- #D  4pcs
- #E  8pcs
- #F  4pcs
- #G 
- #H 



Align the side rail ends to the footboard (#2), then insert the bolts (#B) with flat washers (#E) into each hole. Secure.



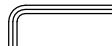

Align the support legs (#9) to the holes along the slats (#7,8), insert a bolt (#C) with flat washer (#E) into each hole from above.

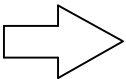
- #C  6pcs
- #E  6pcs
- #G 

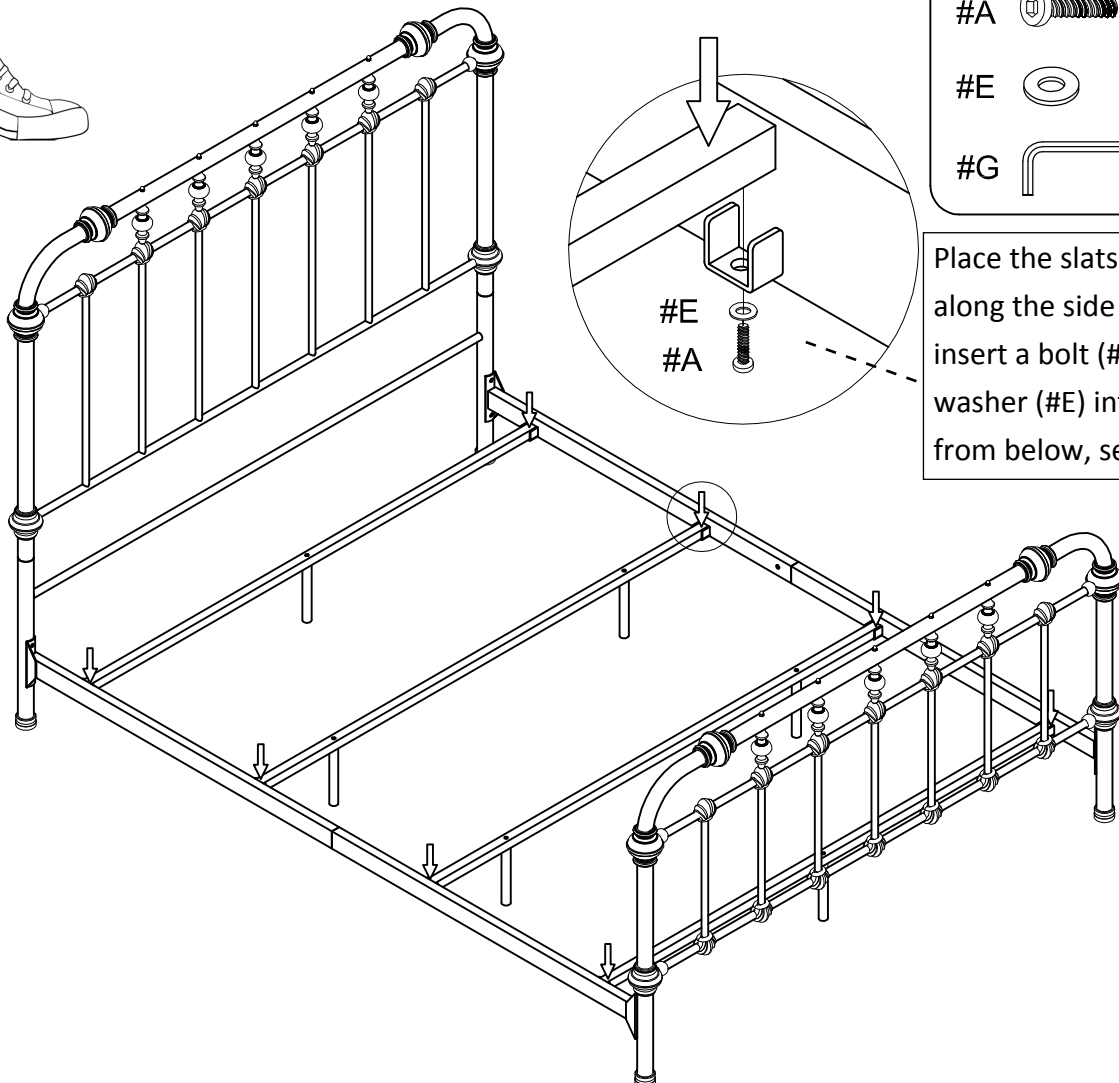
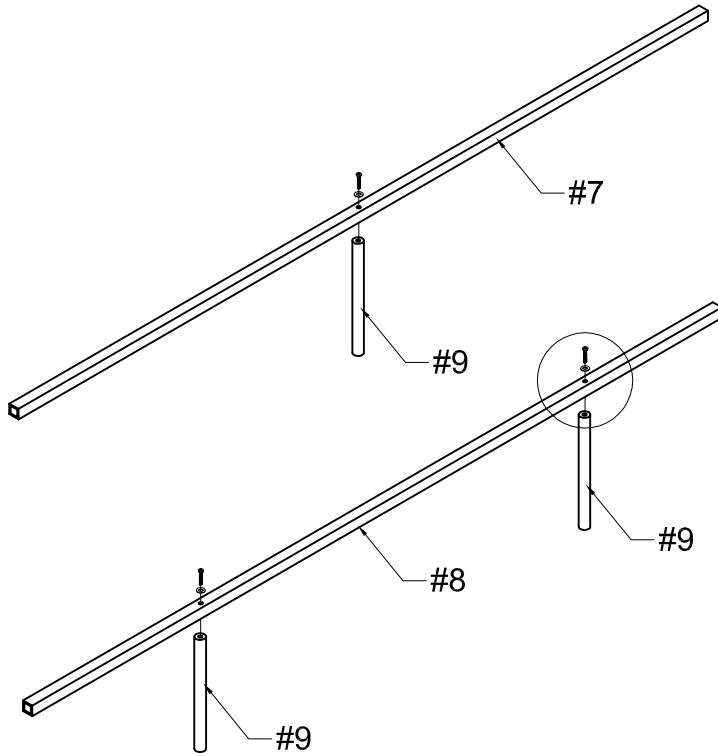
x2 



- #A  8pcs
- #E  8pcs
- #G 

Place the slats onto the slots along the side rails then, insert a bolt (#A) with flat washer (#E) into each hole from below, secure.