



HOSHIZAKI

Parts List

Steelheart Series
Refrigerated Kitchen Equipment

Models

RIA, FIA

R2A, F2A

R3A, F3A

Full Glass (FG), Full Solid (FS)

Half Glass (HG), Half Solid (HS)



hoshizakiamerica.com

Number: 71422
Issued: 1-15-2019
Revised: 7-31-2025

CONTENTS

Auxiliary Codes.....	3
Note About Ordering Parts	7
A. Main Assembly	8
_1A-FG/FGCL/FGCR/FS/FSC/L/FSCR/FSJ/FSL/FSLJ/HG/HS/HSL	8
_2A-FG/FGN/FGEN/FS/FSN/FSC/HG/HS	11
_3A-FG/FGCL/FGCR/FS/FSC/L/FSCR/HG/HS.....	14
_3A-FG/FGCL/FGCR/FS/FSC/L/FSCR/HG/HS.....	15
B. Refrigeration Circuit.....	18
_1A-FG/FGCL/FGCR/FS/FSC/L/FSCR/FSJ/FSL/FSLJ/HG/HS/HSL	
_2A-FG/FGN/FS/FSC/FSN/HG/HS	
_3A-FG/FGCL/FGCR/FS/FSC/L/FSCR/HG/HS.....	18
C. Door-Full Glass.....	22
Right Hinged	22
Left Hinged.....	23
D. Door-Full Solid	25
Right Hinged	25
Left Hinged.....	26
E. Door-Half Glass	28
Right Hinged	28
Left Hinged.....	29
F. Door-Half Solid	31
Right Hinged	31
Left Hinged.....	32
G. Accessories & Labels.....	34
_1A-FG/FGCL/FGCR/FS/FSJ/FSL/FSLJ/HG/HS/HSL,	
_2A-FG/FGN/FS/HG/HS, _3A-FG/FGCL/FGCR/FS/FSC/L/FSCR/HG/HS.....	34

Auxiliary Codes

R1A-FG

H-5 December 2018
J-5 January 2019
J-6 June 2019
J-7 July 2019
K-5 January 2020
K-6 October 2020
L-5 January 2021
M-5 February 2022
N-5 March 2023
N-6 August 2023
P-5 January 2024
P-6 September 2024
Q-5 January 2025

R1A-FGCL

H-5 December 2018
J-5 January 2019
J-6 June 2019
J-7 July 2019
K-5 January 2020
K-6 October 2020
L-5 June 2021
M-5 February 2022
N-5 February 2023
N-6 August 2023
P-5 January 2024
P-6 September 2024
Q-5 January 2025

R1A-FGCR

J-5 January 2019
J-6 June 2019
J-7 July 2019
K-5 January 2020
K-6 October 2020
L-5 March 2021
M-5 February 2022
N-5 May 2023
N-6 October 2023
Q-5 January 2025

R1A-FS

H-5 July 2018
J-5 January 2019
J-6 June 2019
J-7 July 2019
K-5 January 2020
K-6 October 2020
L-5 January 2021
L-6 October 2021
M-5 January 2022
N-5 January 2023
N-6 September 2023
P-5 January 2024
P-6 September 2024
Q-5 January 2025

R1A-FSCL

M-5 June 2022
N-5 January 2023
N-6 October 2023
P-5 April 2024
P-6 September 2024
Q-5 January 2025

R1A-FSCR

M-5 June 2022
N-5 January 2023
N-6 August 2023
P-5 April 2024
P-6 September 2024
Q-5 January 2025

R1A-FSJ

J-5 March 2019
J-6 May 2020
J-7 July 2019
L-5 January 2021
M-5 March 2022
N-5 May 2023
N-6 August 2023
P-5 August 2024
P-6 September 2024
Q-5 January 2025

R1A-FSL

H-5 December 2018
J-5 January 2019
J-6 June 2019
J-7 July 2019
K-5 February 2020
K-6 October 2020
L-5 January 2021
L-6 October 2021
M-5 February 2022
N-5 February 2023
N-6 August 2023
P-5 January 2024
P-6 September 2024
Q-5 January 2025

R1A-FSLJ

J-5 March 2019
J-6 May 2019
J-7 August 2019
K-5 August 2020
L-5 January 2021
M-5 March 2022
N-5 April 2023
N-6 August 2023
P-5 January 2024
P-6 September 2024
Q-5 January 2025

R1A-HG

J-5 January 2019
J-6 June 2019
J-7 September 2019
J-8 October 2019
K-5 July 2020
K-6 October 2020
L-5 April 2021
M-5 June 2022
N-5 January 2023
N-6 November 2023
P-5 February 2024
Q-5 January 2025

Auxiliary Codes (Continued)

R1A-HS

H-5 July 2018
J-5 April 2019
J-6 June 2019
J-7 July 2019
K-5 February 2020
K-6 October 2020
L-5 January 2021
M-5 February 2022
N-5 January 2023
N-6 August 2023
P-5 January 2024
Q-5 January 2025

R1A-HSL

H-5 December 2018
J-5 February 2019
J-6 June 2019
J-7 July 2019
K-5 February 2020
L-5 January 2021
M-5 February 2022
N-5 January 2023
N-6 November 2023
P-5 February 2024
P-6 October 2024

F1A-FG

J-5 February 2019
K-5 January 2020
L-5 January 2021
M-5 April 2022
N-5 March 2023
N-6 November 2023
P-5 January 2024

F1A-FS

H-5 July 2018
J-5 January 2019
J-6 June 2019
J-7 July 2019
K-5 January 2020
L-5 January 2021
L-6 November 2021
M-5 January 2022
N-5 January 2023
N-6 August 2023
P-5 January 2024
Q-5 January 2025

F1A-FSL

H-5 December 2018
J-5 January 2019
J-6 June 2019
J-7 July 2019
K-5 January 2020
L-5 January 2021
M-5 January 2022
N-5 January 2023
N-6 August 2023
P-5 January 2024
Q-5 January 2025

F1A-HG

J-5 January 2019
J-7 November 2019
K-5 October 2020
L-5 April 2021
M-5 September 2022
N-5 January 2023
N-6 October 2023
P-5 February 2024

F1A-HS

H-5 November 2018
J-5 February 2019
J-6 July 2019
J-7 July 2019
K-5 February 2020
L-5 January 2021
M-5 March 2022
N-5 January 2023
N-6 August 2023
P-5 January 2024
Q-5 January 2025

F1A-HSL

H-5 December 2018
J-5 March 2019
J-6 June 2019
J-7 July 2019
K-5 March 2020
L-5 January 2021
M-5 April 2022
N-5 April 2023
N-6 August 2023
P-5 January 2024
Q-5 February 2025

Auxiliary Codes (Continued)

R2A-FG

H-5 December 2018
J-5 January 2019
J-6 April 2019
J-8 July 2019
J-9 November 2019
K-5 March 2020
L-5 January 2021
M-5 February 2022
N-5 March 2023
N-6 August 2023
P-5 January 2024
P-6 September 2024
Q-5 January 2025

R2A-FGN

M-5 April 2022

R2A-FGEN

P-5 July 2024

R2A-FS

H-5 July 2018
J-5 January 2019
J-6 June 2019
J-7 July 2019
J-8 November 2019
K-5 January 2020
L-5 January 2021
M-5 February 2022
N-5 February 2023
N-6 August 2023
P-5 January 2024
P-6 September 2024
Q-5 January 2025

R2A-FSN

M-5 April 2022
N-5 July 2023
P-5 February 2024
P-6 September 2024
Q-5 January 2025

R2A-FSC

M-5 June 2022
N-5 February 2023
N-6 August 2023
P-5 February 2024
P-6 September 2024
Q-5 January 2025

R2A-HG

J-5 January 2019
J-6 May 2019
J-7 September 2019
K-5 March 2020
L-5 March 2021
M-5 February 2022
N-5 March 2023
N-6 November 2023
P-5 May 2024
P-6 October 2024

R2A-HS

H-5 July 2018
J-5 February 2019
J-6 June 2019
K-5 March 2020
L-5 February 2021
M-5 March 2022
N-5 January 2023
N-6 August 2023
P-5 January 2024

F2A-FG

J-6 May 2019
K-5 May 2020
L-5 April 2021
M-5 February 2022
N-5 May 2023
P-5 January 2024

F2A-FGN

M-5 April 2022

F2A-FGEN

P-5 July 2024

F2A-FS

H-5 July 2018
J-5 January 2019
J-6 June 2019
J-7 July 2019
J-8 November 2019
K-5 January 2020
K-6 May 2020
K-7 December 2020
L-5 January 2021
M-5 February 2022
N-5 January 2023
N-6 August 2023
P-5 July 2024
Q-5 April 2025

F2A-FSN

M-5 April 2022
N-5 July 2023
P-5 September 2024

F2A-HG

J-5 January 2019
J-6 May 2019
M-5 June 2022
N-5 May 2023

F2A-HS

H-5 July 2018
J-5 January 2019
J-6 June 2019
J-7 August 2019
K-5 March 2020
K-6 October 2020
L-5 April 2021
M-5 February 2022
N-5 January 2023
N-6 August 2023
P-5 January 2024

Auxiliary Codes (Continued)

R3A-FG

J-5 March 2019
J-6 June 2019
J-7 July 2019
J-8 November 2019
K-5 February 2020
K-6 November 2020
L-5 February 2021
M-5 February 2022
N-5 March 2023
N-7 November 2023
P-5 February 2024
P-6 October 2024

R3A-FGCL

J-5 January 2019

R3A-FGCR

J-5 March 2019

R3A-FS

J-5 January 2019
J-6 June 2019
J-7 July 2019
J-8 November 2019
K-5 January 2020
K-6 October 2020
L-5 January 2021
M-5 January 2022
N-5 March 2023
N-6 August 2023
N-7 October 2023
P-5 January 2024
P-6 August 2024
Q-5 January 2025

R3A-FSCL

J-5 January 2019

R3A-FSCR

J-5 March 2019
M-5 January 2022

R3A-HG

J-5 July 2019
K-5 August 2020
L-5 March 2021
N-5 May 2023
P-5 April 2024

R3A-HS

H-5 December 2018
J-5 January 2019
J-6 June 2019
L-5 May 2021
M-5 April 2022
N-6 September 2023

F3A-FS

J-5 March 2019
J-6 June 2019
J-7 July 2019
J-8 November 2019
K-5 January 2020
L-5 January 2021
M-5 January 2022
N-5 January 2023
N-7 November 2023
P-5 January 2024
Q-5 January 2025

F3A-HS

H-5 December 2018
J-5 May 2019
J-7 August 2019
K-5 March 2020
M-5 April 2022
N-5 January 2023
N-8 October 2023
P-5 March 2024

Auxiliary Code Breakdown

The auxiliary code is the first two characters in the serial number. The first character indicates the year. Years progress or regress in alphabetical order. The series runs from "A" through "V" and the letters "I" and "O" are skipped. The second character indicates significant part changes within a year. Base is "5" and this number advances for each change. In cases where there is a letter in parentheses, this designates the month. This is the last character in the serial number. The series runs from "(A)" through "(M)" and the letter "(I)" is skipped. This designation is only included when identifying a parts change within an auxiliary code.

Note About Ordering Parts

Most assemblies cannot be ordered as complete units; parts in the assemblies generally must be ordered separately.

A. Main Assembly

_1A-FG/FGCL/FGCR/FS/FSCL/FSCR/FSJ/FSL/FSLJ/HG/HS/HSL

H-5 to Q-5

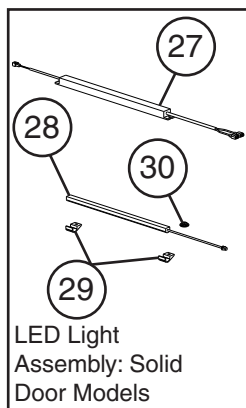
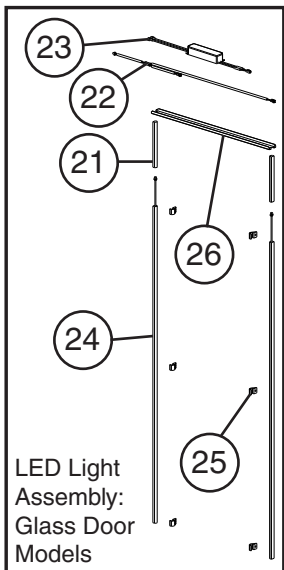
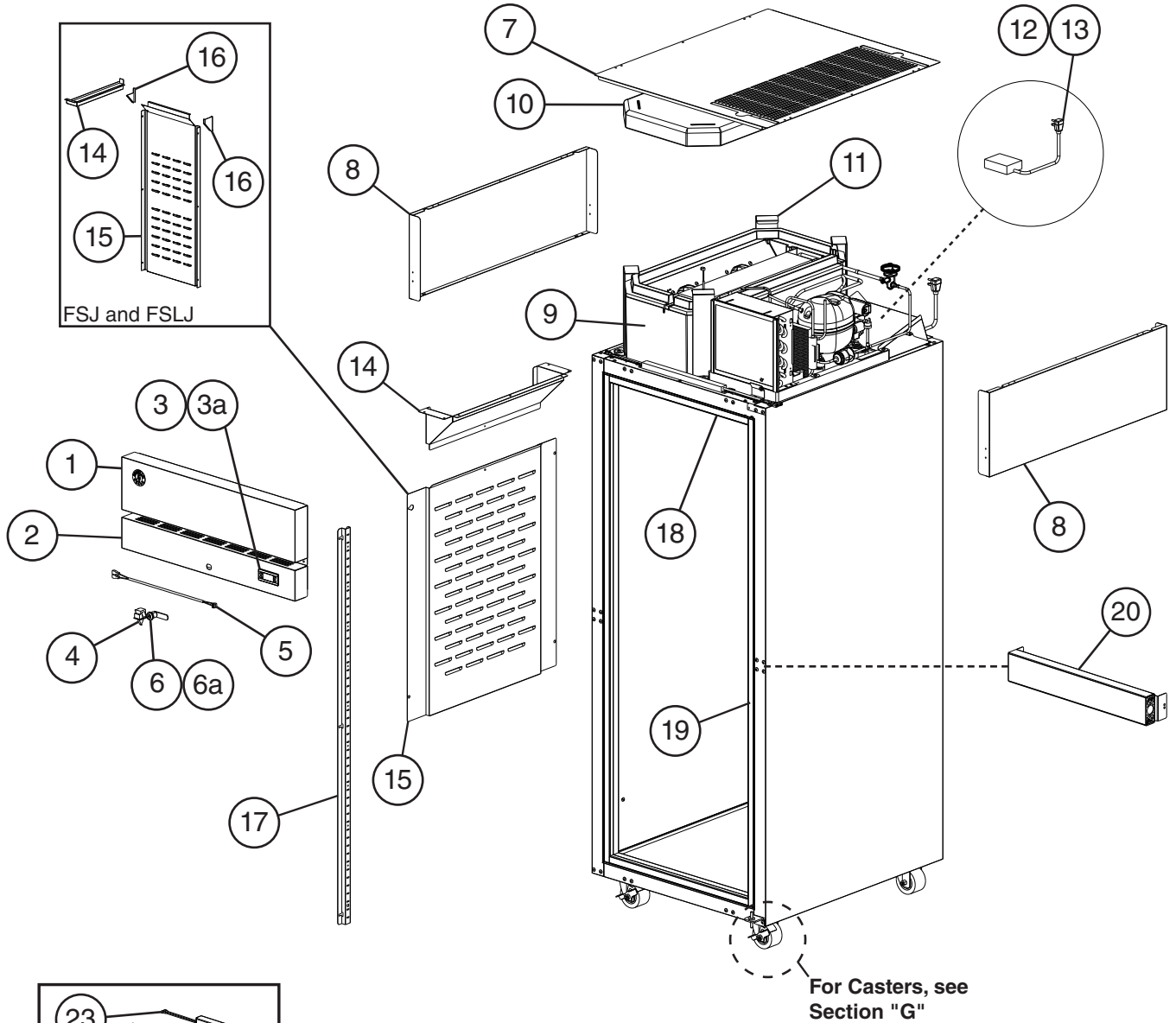

For Doors, see Section "C" through "F"

Title: A. Main Assembly Model: _1A-FG/FGCL/FGCR/FS/FSL/FSCR/FSJ/FSL/FSLJ/HG/HS/HSL												
Index No.	Description	Material or Model Number	Part Number	H-5 to Q-5	Required Number							
1	Front Panel	_1A-XXXX	3A9604G01	1								
2	Control Panel	_1A-XXXX Except -HG Models	2A8615-01	1								
		-HG	2A8651-01	1								
3	Control Module	R1A-FS/FSJ/ FSL/FSLJ/HS/ HSL	4A6195G01	1								
		R1A-FG/FGCL/ FGCR/HG	4A6626G01	1								
		F1A-FS/FSL/ HS/HSL	4A6196G01	1								
		F1A-FG/HG	4A6627G01	1								
3a	Control Module Mounting Clip		4A5502-01	2								
4	Door Switch		3A1826-01	-								
			3B2145-01	1								
5	Door Switch Wire Harness		4A6203-01	1								
6	Lock (includes item 6a)		4A4924-01	1								
6a	Key (includes 2 keys)		4A5453-01	1								
7	Top Louver		2A9682-01	1								
8	Side Panel		2A8252-01	2								
9	Evaporator Case		1A6860-01	1	Aux. Code M-5 and Earlier order items 9 and 10 together.							
10	Evaporator Cover		1A6861-01	1								
11	Evaporator Case Latch		3A9802-01	4								
12	Power Supply Cord/ Wire Harness		3A9838-01	1								
13	Connector Cap	R1A-XXXX	4A6229-01	4								
14	Air Distribution Top	_1A-XXXX Except -FSJ, -FSLJ	1A3951-01	1								
		-FSJ, -FSLJ	2A9236-01	1								
15	Air Distribution Panel	_1A-XXXX Except -FSJ, -FSLJ	1A4930-01	1								
		-FSJ, -FSLJ	1A5710-01	1								
16	Air Distribution Cap	-FSJ, -FSLJ (Right)	2A9237-01	1								
		-FSJ, -FSLJ (Left)	2A9238-01	1								
17	Pilaster		3A0145-01	4								
18	Horizontal Thermal Breaker Cover	561 mm	2A8795-01	2								
19	Vertical Thermal Breaker Cover	1552 mm	2A8796-01	2								

Title: A. Main Assembly Model: _1A-FG/FGCL/FGCR/FS/FSCL/FSCR/FSJ/FSL/FSLJ/HG/HS/HSL												
Index No.	Description	Material or Model Number	Part Number	H-5 to Q-5	Required Number							
20	Horizontal Mullion	R1A-HS/HG/HSL	2A8664A01	1								
		F1A-HS/HG/HSL	2A8824A01	1								
21	LED Lens (wire sleeve)	-FG, -FGCL, -FGCR, -HG	3A9861-01	2								
22	LED Y Harness		4A6080-01	1								
23	LED Driver		3A9820-01	1								
24	LED Lamp		3A9868-01	2								
25	LED Clip		4A5906-01	6								
26	LED Bracket		2A8826-01	1								
27	LED Driver	-FS, -FSCL, -FSJ, -FSL, -FSLJ, -HS, -HSL	3A9867-01	1								
28	LED Lamp		3A9788-01	1								
29	LED Clip		4A5906-01	2								
30	LED Bushing		425307-02	1								

A. Main Assembly
2A-FG/FGN/FGEN/FS/FSN/FSC/HG/HS
 H-5 to Q-5

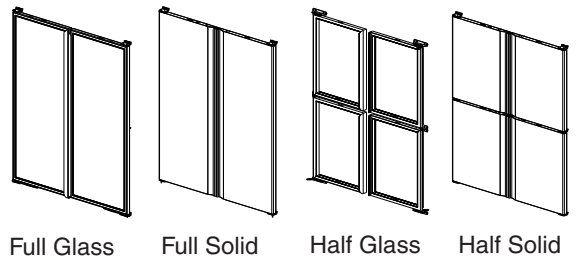
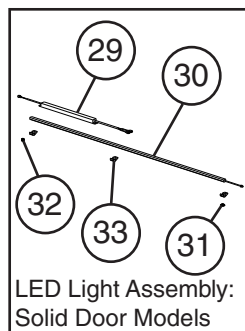
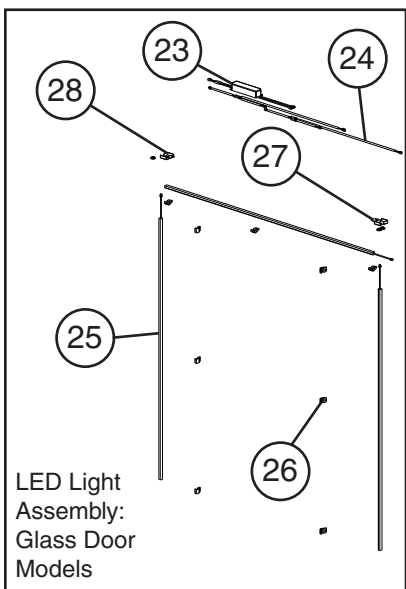
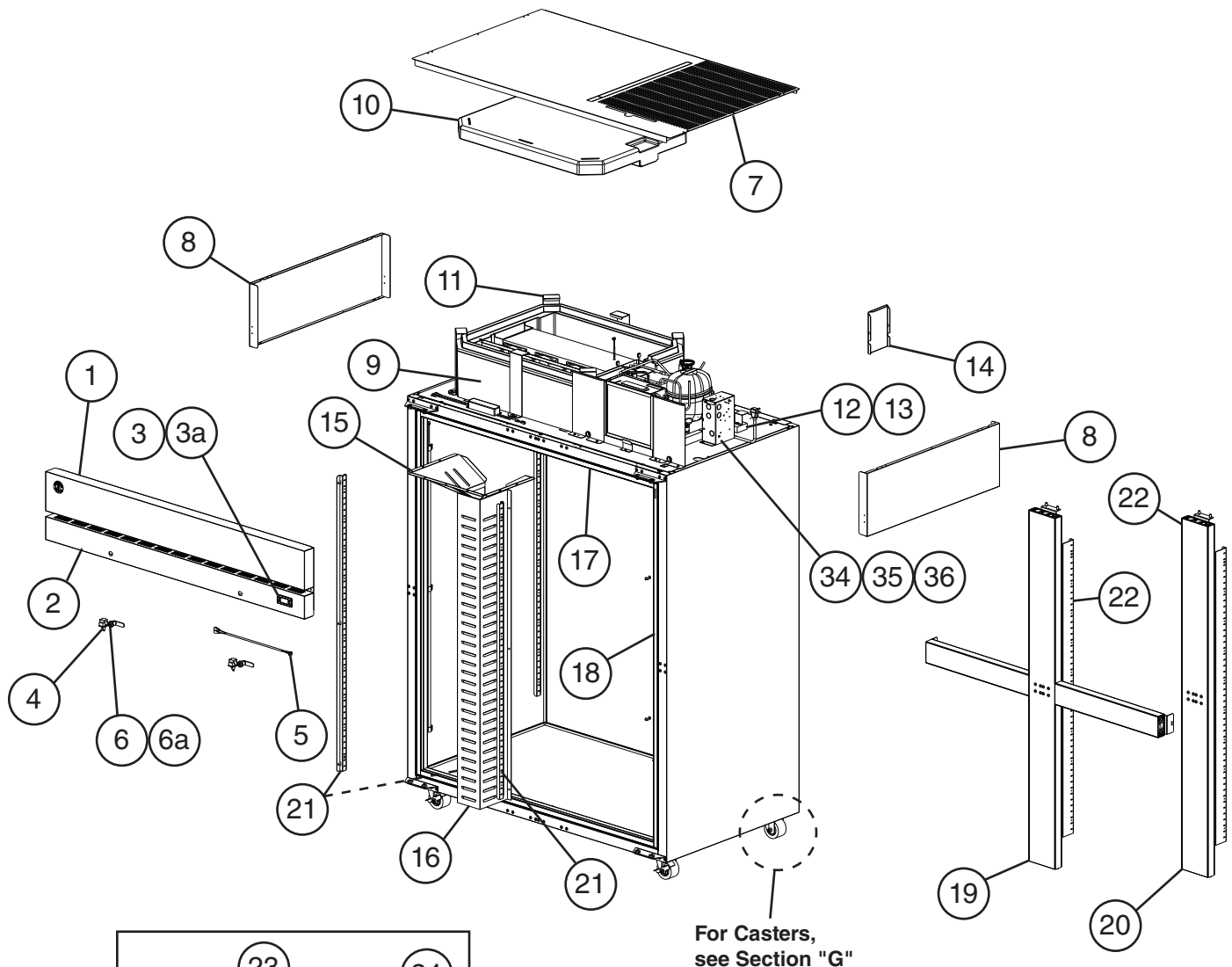

For Doors, see Sections "C" through "F"

Title: A. Main Assembly Model: 2A-FG/FGN/FGEN/FS/FSN/FSC/HG/HS												
Index No.	Description	Material or Model Number	Part Number	H-5 to Q-5	Required Number							
1	Front Panel	_2A-XXXX	3A9740G01	1								
		_2A-FGN/FGEN/FSN	3B1235G01	1								
2	Control Panel	_2A-FG/FS/FSC/HS	2A8583-01	1								
		_2A-FGN/FGEN/FSN	2B0210-01	1								
		_2A-HG	2A8726-01	1								
3	Control Module	R2A-FS/FSC/FSN/HS	4A6195G01	1								
		R2A-FG/FGN/FGEN/HG	4A6626G01	1								
		F2A-FS/FSN/HS	4A6196G01	1								
		F2A-FG/FGN/FGEN/HG	4A6627G01	1								
3a	Control Module Mounting Clip		4A5502-01	2								
4	Door Switch		3B2145-01	2								
5	Door Switch Wire Harness		4A6203-01	1								
6	Lock (includes item 6a)		4A4924-01	2								
6a	Key (includes 2 keys)		4A5453-01	2								
7	Top Louver	F2A-HG/HS R2A-FG/FS/HS	2A9683-01	1								
		_2A-FGN/FGEN/FSN	2B0211-01	1								
8	Side Panel		2A8252-01	2								
9	Evaporator Case		1A6862-01	1	Aux. Code M-5 and Earlier order items 9 and 10 together.							
10	Evaporator Cover		1A6863-01	1								
11	Evaporator Case Latch		3A9802-01	6								
12	Power Supply Cord/ Wire Harness		3A9838-01	1								
13	Connector Cap (filler connector)	R2A-XXXX	4A6229-01	4								
14	Control Box Cover	F2A-XXXX	3B0037-01	1								
15	Air Distribution Top		1A3950-03	1								
16	Air Distribution Channel		1A5035-01	1								
17	Horizontal Thermal Breaker Cover	1260 mm _2AFG/FS/FSC/ HG/HS	2A8795-02	2								
		1181 mm _2A-FGN/FGEN/ FSN	2A8795-04	2								
18	Vertical Thermal Breaker Cover	1552 mm	2A8796-01	2								
19	Cross Mullion (Includes 2 Mullion Pilasters)	R2A-HS/HG	2A8746A01	1								
		F2A-HS/HG	2A8836A01	1								
20	Vertical Mullion (Includes 2 Mullion Pilasters)	R2A-XXXX	2A8734A01	1								
		F2A-XXXX	2A8835A01	1								
21	Pilaster		3A0145-01	6								
22	Mullion Pilaster		2A9426-01	2								

Title: A. Main Assembly Model: _2A-FG/FGN/FGEN/FS/FSN/FSC/HG/HS												
Index No.	Description	Material or Model Number	Part Number	H-5 to Q-5	Required Number							
23	LED Driver	_2A-FG/FGN/FGEN/HG	3A9820-01	1								
24	LED Y Harness		4A6080-01	2								
25	LED Lamp		3A9868-01	3								
26	LED Clip		4A5906-01	9								
27	LED Bracket (Right)	_2A-FG/HG/FGE	3B0243-01	1								
		_2A-FGN/FGEN	3B1242-01	1								
28	LED Bracket (Left)	_2A-FG/HG/FGE	3B0243-02	1								
		_2A-FGN/FGEN	3B1242-02	1								
29	LED Driver	_2A-FS/HS	3A9867-01	1								
30	LED Lamp		3A9868-01	1								
31	Bushing		425307-02	1								
32	Hole Plug		4A0586-10	1								
33	LED Clip		4A5906-01	3								
Control Box												
34	Start Relay	F2A-XXXX	4A6386-01	1								
35	Start Capacitor	F2A-XXXX	4A6381-01	1								
36	Run Capacitor	F2A-XXXX	4A6382-01	1								

A. Main Assembly

3A-FG/FGCL/FGCR/FS/FSCL/FSCR/HG/HS

1/2

H-5 to Q-5

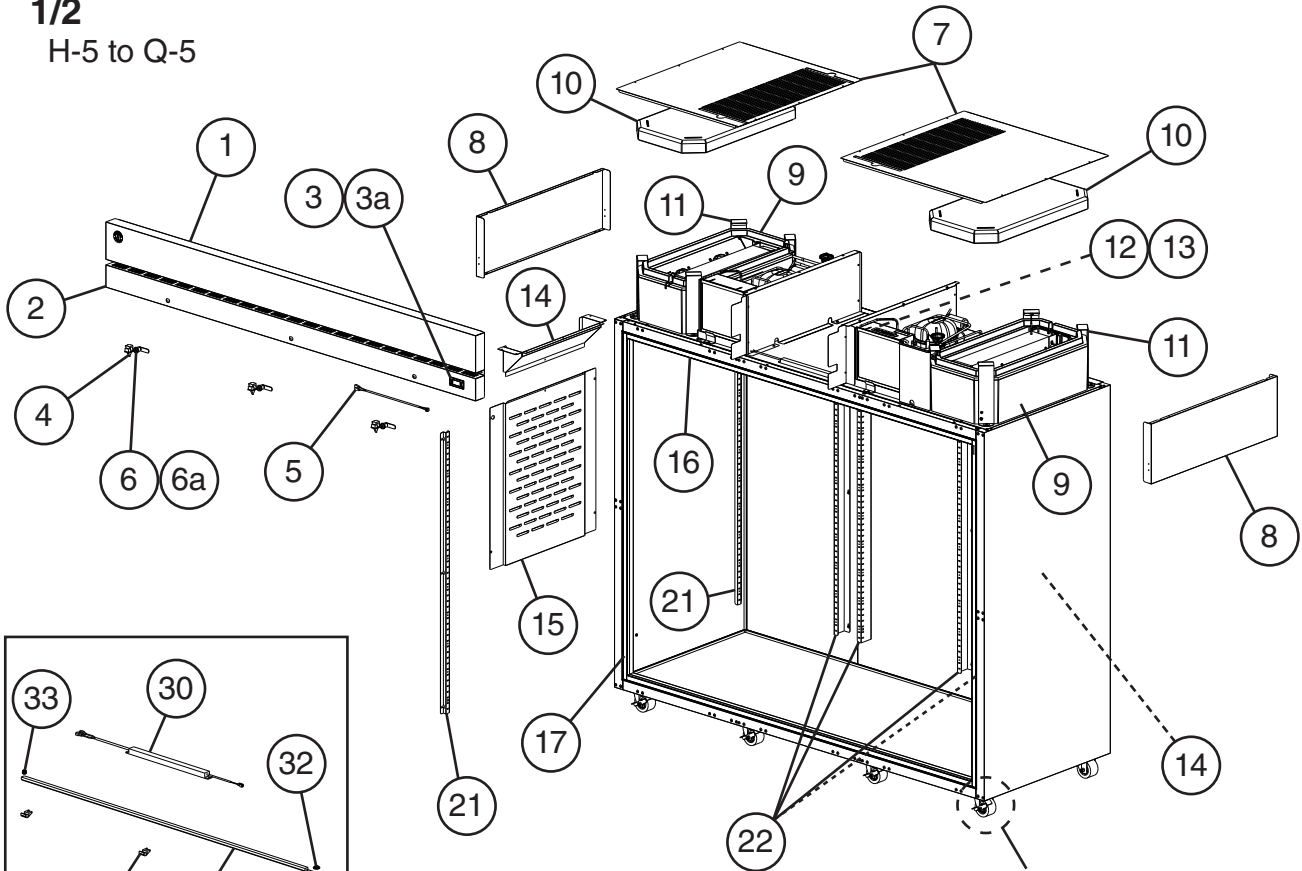

For Casters, see Section "G"

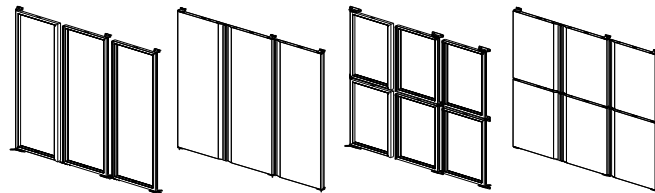
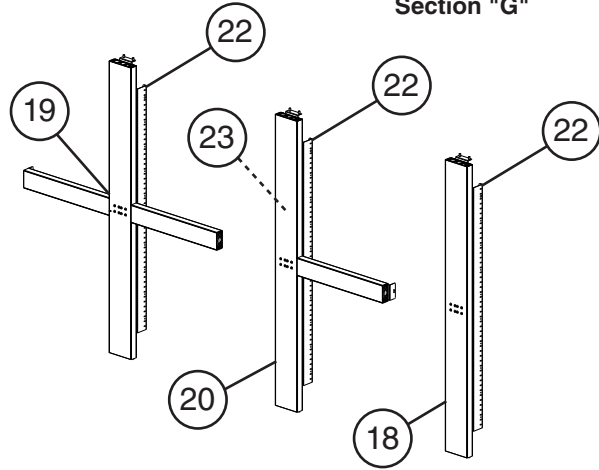
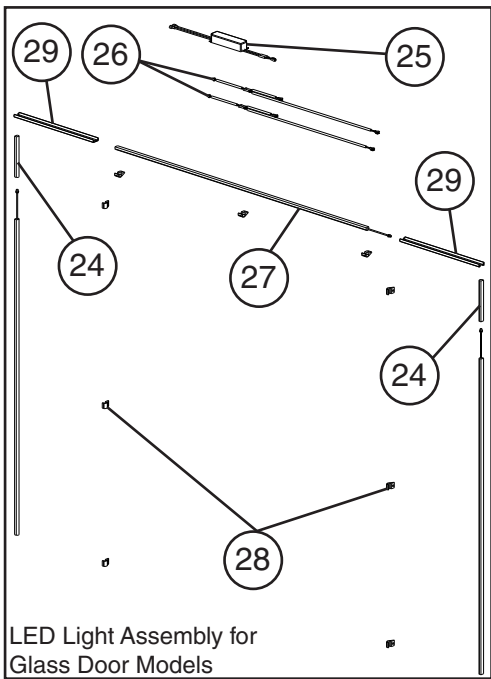
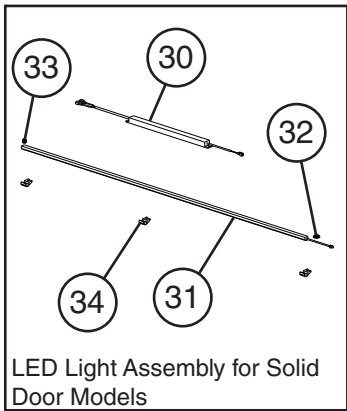

Full Glass Full Solid Half Glass Half Solid

For Doors, see Sections "C" through "F"

A. Main Assembly

_3A-FG/FGCL/FGCR/FS/FSCL/FSCR/HG/HS

2/2

H-5 to Q-5

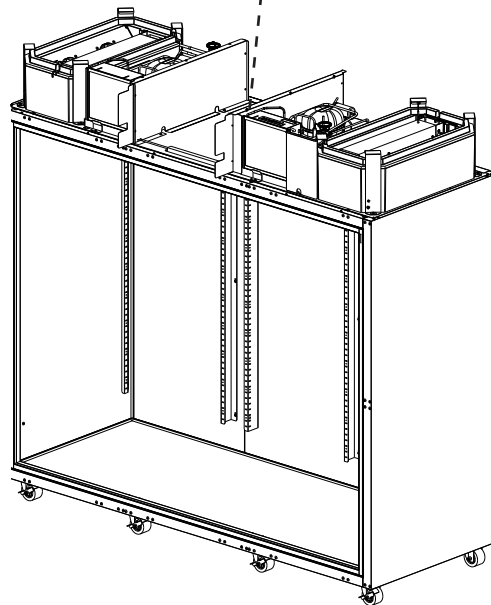
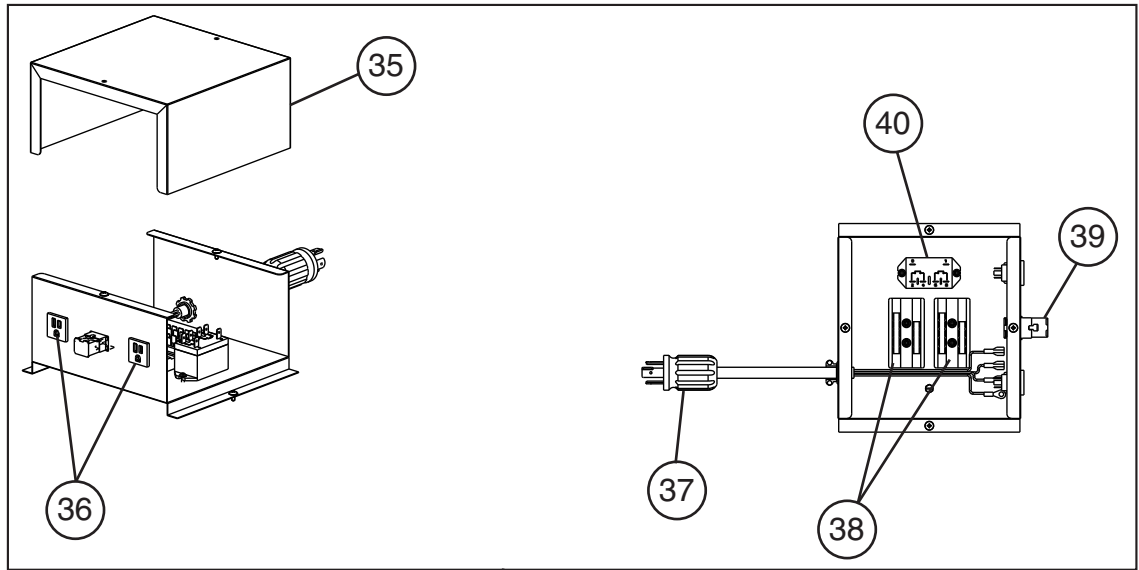

Title: A. Main Assembly Model: _3A-FG/FGCL/FGCR/FS/FSCL/FSCR/HG/HS												
Index No.	Description	Material or Model Number	Part Number	H-5 to Q-5	Required Number							
1	Front Panel		3A9914G01	1								
2	Control Panel	R3A-XXXX Except R3A-HG	1A5164-01	1								
		R3A-HG	1A5259-01	1								
3	Control Module	R3A-FS/FSCL/FSCR/HS	4A6195G01	1								
		R3A-FG/FGCL/FGCR/HG	4A6626G01	1								
		F3A-HS/FS	4A6196G01	1								
3a	Control Module Mounting Clip		4A5502-01	2								
4	Door Switch		3A1826-01	-								
			3B2145-01	3								
5	Door Switch Harness		4A6203-01	1								
6	Lock (includes item 6a)		4A4924-01	3								
6a	Key (includes 2 keys)		4A5453-01	3								
7	Top Louver	Left	2A9682-01	1								
		Right	2A9685-01	1								
		Center	2A9684-01	1								
8	Side Panel		2A8252-01	2								
9	Evaporator Case		1A6860-01	2	Aux. Code M-5 and Earlier order items 9 and 10 together.							
10	Evaporator Cover		1A6861-01	2								
11	Evaporator Case Latch		3A9802-01	8								
12	Power Supply Cord	R3A-XXXX	4A0520-01	1								
		F3A-XXXX	4A6500-01	1								
13	Control Box Cover		2A9098-01	1								
14	Air Distribution Top		1A3951-01	2								
15	Air Distribution Panel		1A4930-01	2								
16	Horizontal Thermal Breaker Cover	1958 mm	2A8795-03	2								
17	Vertical Thermal Breaker Cover	1552 mm	2A8796-01	2								
18	Vertical Mullion (Includes 2 Pilaster)	R3A-XXXX Except -HG/HS Models	2A8734A01	2								
		F3A-FS	2A8835A01	2								
19	Cross Mullion (Includes 2 Pilaster)	R3A-HG/HS	2A8892A01	1								
		F3A-HS	2A8893A01	1								
20	Tee Mullion (Includes 2 Pilaster)	R3A-HG/HS	2A8747A01	1								
		F3A-HS	2A8837A01	1								
21	Pilaster	_3A-XXXX	3A0145-01	4								
22	Mullion Pilaster	_3A-XXXX Except -HG/HS Models	2A9426-01	8								
		-HG/HS		7								

Title: A. Main Assembly Model: _3A-FG/FGCL/FGCR/FS/FSCL/FSCR/HG/HS											
Index No.	Description	Material or Model Number	Part Number	Required Number							
				H-5 to Q-5							
23	Tee Mullion Pilaster	-HG/HS	2A9427-01	1							
24	LED Lens	3A-FG/FGCL/FGCR/HG	3A9861-01	2							
25	LED Driver		3A9820-01	1							
26	LED Y Harness		4A6080-01	2							
27	LED Lamp		3A9868-01	3							
28	LED Clip		4A5906-01	9							
29	LED Bracket		2A8894-01	2							
30	LED Driver	3A-FS/FSCL/FSCR/HS	3A9867-01	1							
31	LED Lamp		3A9868-01	1							
32	Bushing		425307-02	1							
33	Hole Plug		4A0586-10	1							
34	LED Clip		4A5906-01	3							
35	Control Box Cover		2A9098-01	1							
36	Receptacle		4A6494-01	2							
37	Power Cord	Refrigerator	4A0520-01	1							
		Freezer	4A6500-01	1							
38	Terminal Block	Freezer	4A2619-01	2							
39	Wire Harness	Refrigerator	3B0217-01	1							
		Freezer	3B0218-01	1							
40	Compressor Relay	Freezer	4A3140-02	1							

B. Refrigeration Circuit

_1A-FG/FGCL/FGCR/FS/FSC/FSJ/FSL/FSLJ/HG/HS/HSL

_2A-FG/FGN/FS/FSC/FSN/HG/HS

_3A-FG/FGCL/FGCR/FS/FSC/FSJ/HG/HS

H-5 to Q-5

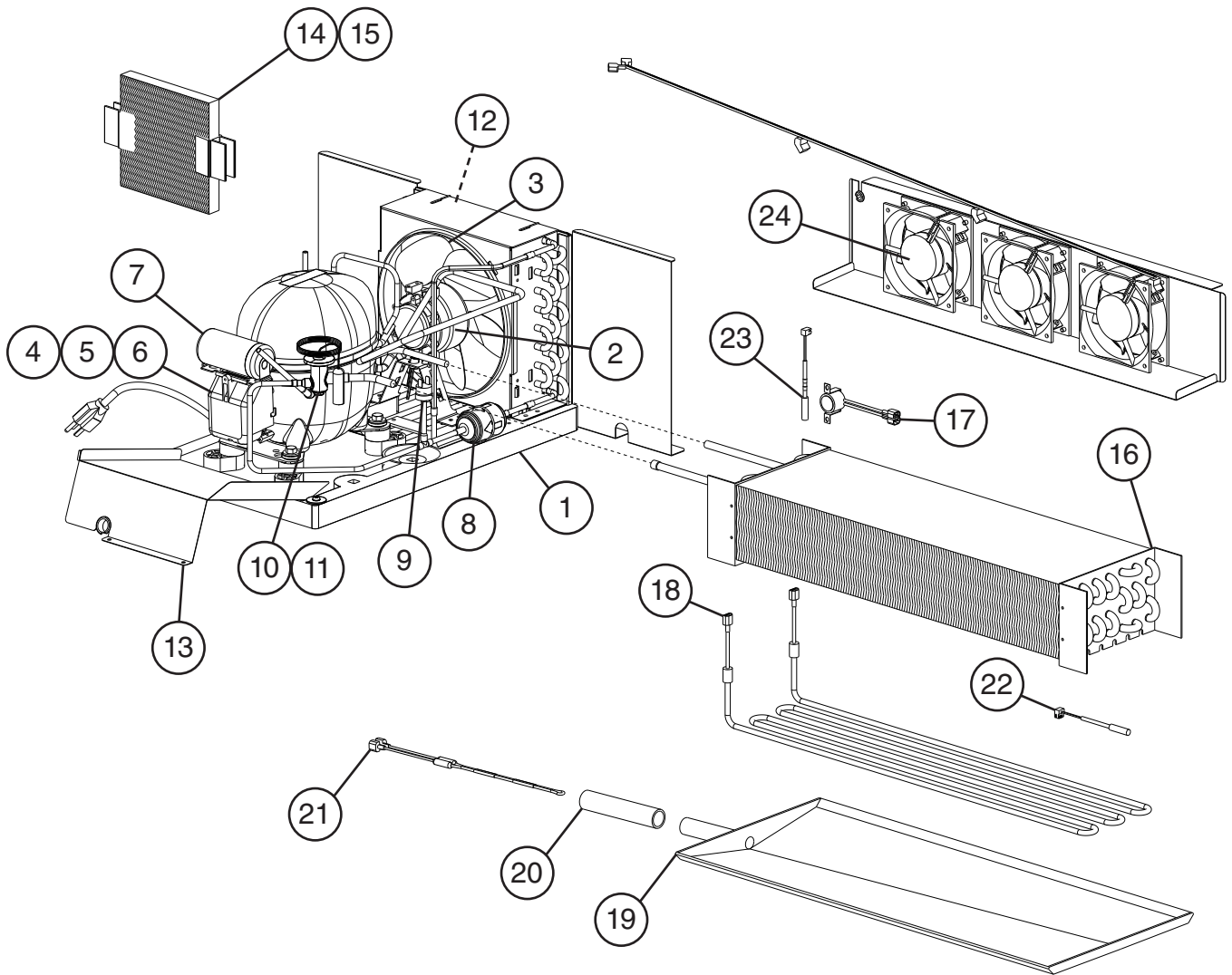

Title: B. Refrigeration Circuit Model: _1A-FG/FGCL/FGCR/FS/FSJ/FSL/FSLJ/HG/HS/HSL, _2A-FG/FGN/FS/HG/HS, _3A-FG/FGCL/FGCR/FS/FSCL/FSCR/HG/HS											
Index No.	Description	Material or Model Number	Part Number	Required Number							
				H-5 to L-5	M-5 to Q-5						
1	Condensing Unit (includes compressor, condenser, and items 2 through 8, compressor and condenser are not sold individually)	R1A-XXXX	2A8791-01	1	1						
		R3A-XXXX		2	2						
		F1A-XXXX	2A8792-01	1	1						
		F3A-XXXX		2	2						
		R2A-XXXX	2A8793-01	1	1						
	Condensing Unit (includes compressor, condenser, control box (start relay, start capacitor, and run capacitor) and items 2, 3, 6 through 8, compressor and condenser are not sold individually)	F2A-XXXX	2A8794-01	1	1						
2	Condenser Fan Motor	_1A-XXXX, _2A-XXXX	4A6376-01	1	1						
		_3A-XXXX		2	2						
3	Condenser Fan Blade	_1A-XXXX, _2A-XXXX	4A6377-01	1	1						
		_3A-XXXX		2	2						
4	Compressor External Protector	R1A-XXXX	4A6927-01	1	1						
		R3A-XXXX		2	2						
		R2A-XXXX	4A6928-01	1	1						
		F1A-XXXX	4A6389-01	1	1						
		F3A-XXXX		2	2						
5	Start Relay	R1A-XXXX	4A6383-01	1	1						
		R3A-XXXX		2	2						
		R2A-XXXX	4A6384-01	1	1						
		F1A-XXXX	4A6385-01	1	1						
		F3A-XXXX		2	2						
6	Condensing Unit Power Supply Cord	R1A-XXXX, R2A-XXXX	4A6501-01	1	1						
		R3A-XXXX		2	2						
		F1A-XXXX	4A6502-01	1	1						
		F3A-XXXX		2	2						
		F2A-XXXX	4A6503-01	1	1						
7	Start Capacitor	R1A-XXXX	4A6378-01	1	1						
		R3A-XXXX		2	2						
		R2A-XXXX	4A6379-01	1	1						
		F1A-XXXX	4A6380-01	1	1						
		F3A-XXXX		2	2						
8	Drier	_1A-XXXX, _2A-XXXX	4A1113-01	1	1						
		_3A-XXXX		2	2						
9	High-Pressure Switch	R1A-XXXX, R2A-XXXX	4A6039-01	1	1						
		R3A-XXXX		2	2						
		F1A-XXXX, F2A-XXXX	4A7399-01	1	1						
		F3A-XXXX		2	2						

Title: B. Refrigeration Circuit Model: _1A-FG/FGCL/FGCR/FS/FSJ/FSL/FSLJ/HG/HS/HSL, _2A-FG/FGN/FS/HG/HS, _3A-FG/FGCL/FGCR/FS/FSCL/FSCR/HG/HS											
Index No.	Description	Material or Model Number	Part Number	Required Number							
				H-5 to L-5	M-5 to Q-5						
10	Thermostatic Expansion Valve (R_A-XXXX, F1A-XXXX, and F3A-XXXX includes item 11)	R1A-XXXX	4A6869A01	1	1						
		R2A-XXXX	4A7211A01	1	1						
		R3A-XXXX	4A6869A01	2	2						
		F1A-XXXX	4A7212A01	1	1						
		F2A-XXXX	4A7213A01	1	1						
		F3A-XXXX	4A7212A01	2	2						
11	Thermostatic Expansion Valve Cover	R1A-XXXX	4A6201-01	1	1						
		R2A-XXXX	4A7233-01	1	1						
		R3A-XXXX	4A6201-01	2	2						
		F1A-XXXX	4A7233-01	1	1						
		F2A-XXXX	4A7233-01	1	1						
		F3A-XXXX	4A7233-01	2	2						
12	Air Filter	_1A-XXXX, _2A-XXXX	4A6189-01	1	1						
		_3A-XXXX		2	2						
13	Deflector	_1A-XXXX, _3A-XXXX	2A9004-01	1	1						
14	Wick	R1A-XXXX, R2A-XXXX	4A6188-01	1	1						
		R3A-XXXX		2	2						
15	Wick Retainer	R1A-XXXX, R2A-XXXX	4A6164-01	2	2						
		R3A-XXXX		4	4						
16	Evaporator	_1A-XXXX	2A8783-01	1	-						
			2A9932-01		1						
		R2A-XXXX	2A8631-01	1	-						
			2B0024-01		1						
		_3A-XXXX	2A8783-01	2	-						
			2A9932-01		2						
17	Defrost Thermostat	F1A-XXXX, F2A-XXXX	4A6194-01	1	1						
		F3A-XXXX		2	2						
18	Defrost Heater	F1A-XXXX	3A9800-01	1	1						
		F3A-XXXX		2	2						
		F2A-XXXX	3A9801-01	1	1						
19	Evaporator Drain Pan	_1A-XXXX	1A4805-01	1	1						
		_3A-XXXX		2	2						
		_2A-XXXX	1A4827-01	1	1						
20	Drain Hose	_1A-XXXX	7716B2025	1	1						
		_2A-XXXX		1	1						
		_3A-XXXX		2	2						
21	Drain Tube Heater	F1A-XXXX, F2A-XXXX	4A6197-01	1	1						
		F3A-XXXX		2	2						

Title: B. Refrigeration Circuit Model: _1A-FG/FGCL/FGCR/FS/FSJ/FSL/FSLJ/HG/HS/HSL, _2A-FG/FGN/FS/HG/HS, _3A-FG/FGCL/FGCR/FS/FSC/L/FSCR/HG/HS											
Index No.	Description	Material or Model Number	Part Number	Required Number							
				H-5 to L-5	M-5 to Q-5						
22	Cabinet Thermistor	_1A-XXXX, _2A-XXXX, _3A-XXXX	4A4864-02	1	1						
23	Defrost Thermistor	_1A-XXXX, _2A-XXXX	4A4865-02	1	1						
		_3A-XXXX	4A4865-03	1	1						
24	Evaporator Fan Motor	_1A-XXXX	4A6192-01	2	2						
		_2A-XXXX		3	3						
		_3A-XXXX		4	4						

**C. Door-Full Glass
Right Hinged
1/2**
H-5 to Q-5

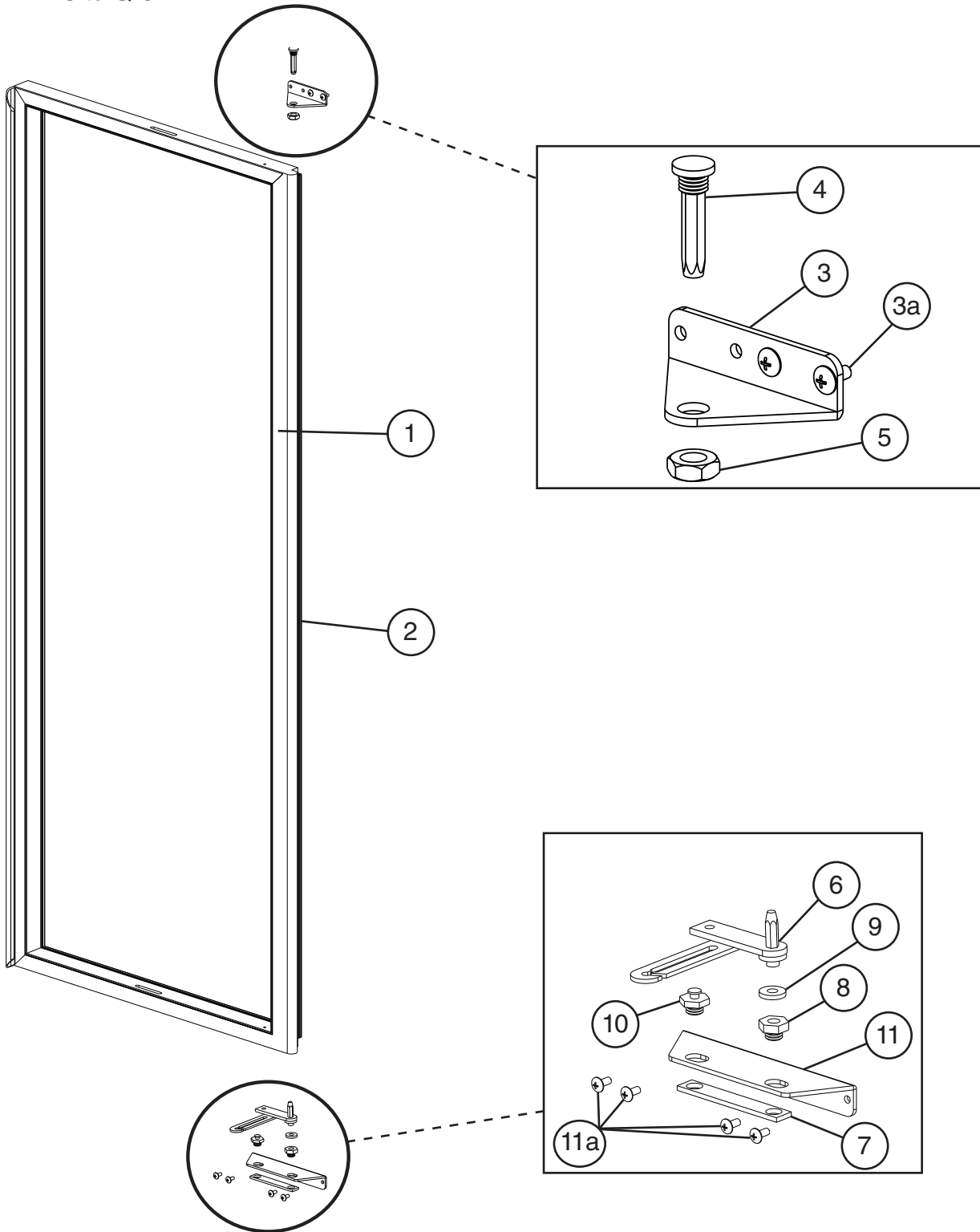

C. Door-Full Glass
Left Hinged
2/2
H-5 to Q-5

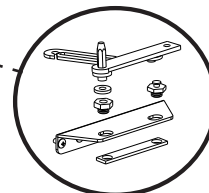
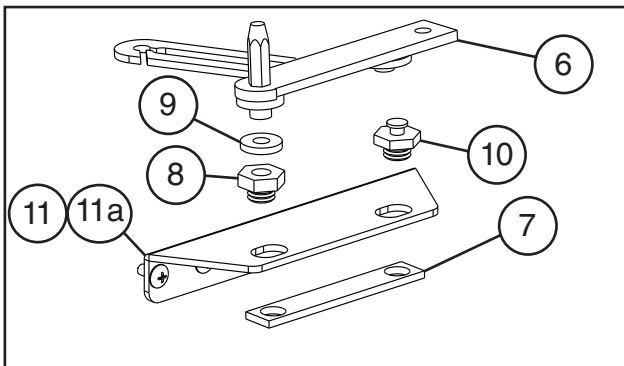
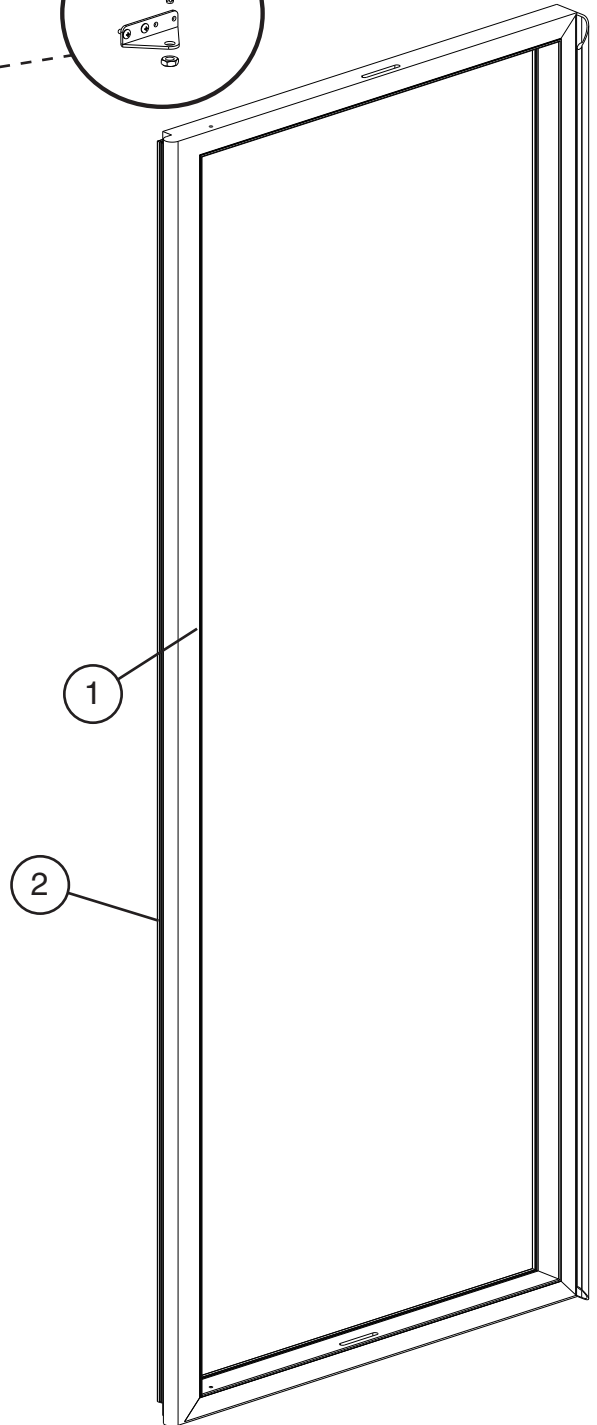
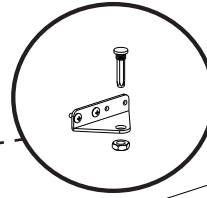
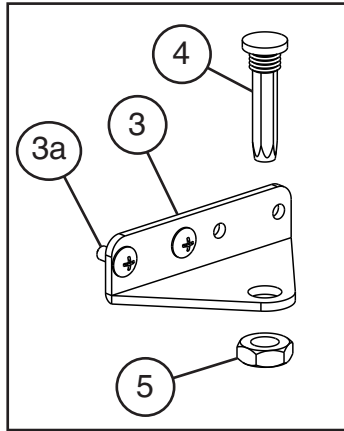

Title: C. Door-Full Glass Model: Full Glass												
Index No.	Description	Material or Model Number	Part Number	H-5 to Q-5	Required Number							
1	Right Glass Door	R_A-FG/FGCR	2A7834-03	1								
		F_A-FG	2A7834-04	1								
		R2A-FGN	2B0202-03	1								
		F2A-FGN	2B0202-04	1								
	Left Glass Door	R_A-FG/FGCL	2A7834-01	1								
		F_A-FG	2A7834-02	1								
		R2A-FGN	2B0202-01	1								
		F2A-FGN	2B0202-02	1								
2	Gasket		3A8864-01	1								
3	Upper Hinge Bracket		3A9162-01	1								
3a	Truss Head Screw	5x12, SS	7C32-0512	2								
4	Tension Rod (hinge pin)		3A7946-04	1								
5	Lock Nut		3A7946-05	1								
6	Lower Hinge Arm		3A7946-01	1								
7	Backer Plate		3A7946-08	1								
8	Bottom Hinge Bushing		3A7946-09	1								
9	Nylon Washer		3A7946-10	1								
10	Slide Pin		3A7946-11	1								
11	Lower Hinge Bracket		3A9161-01	1								
11a	Truss Head Screw	5x12, SS	7C32-0512	4								

**D. Door-Full Solid
Right Hinged
1/2**
H-5 to Q-5

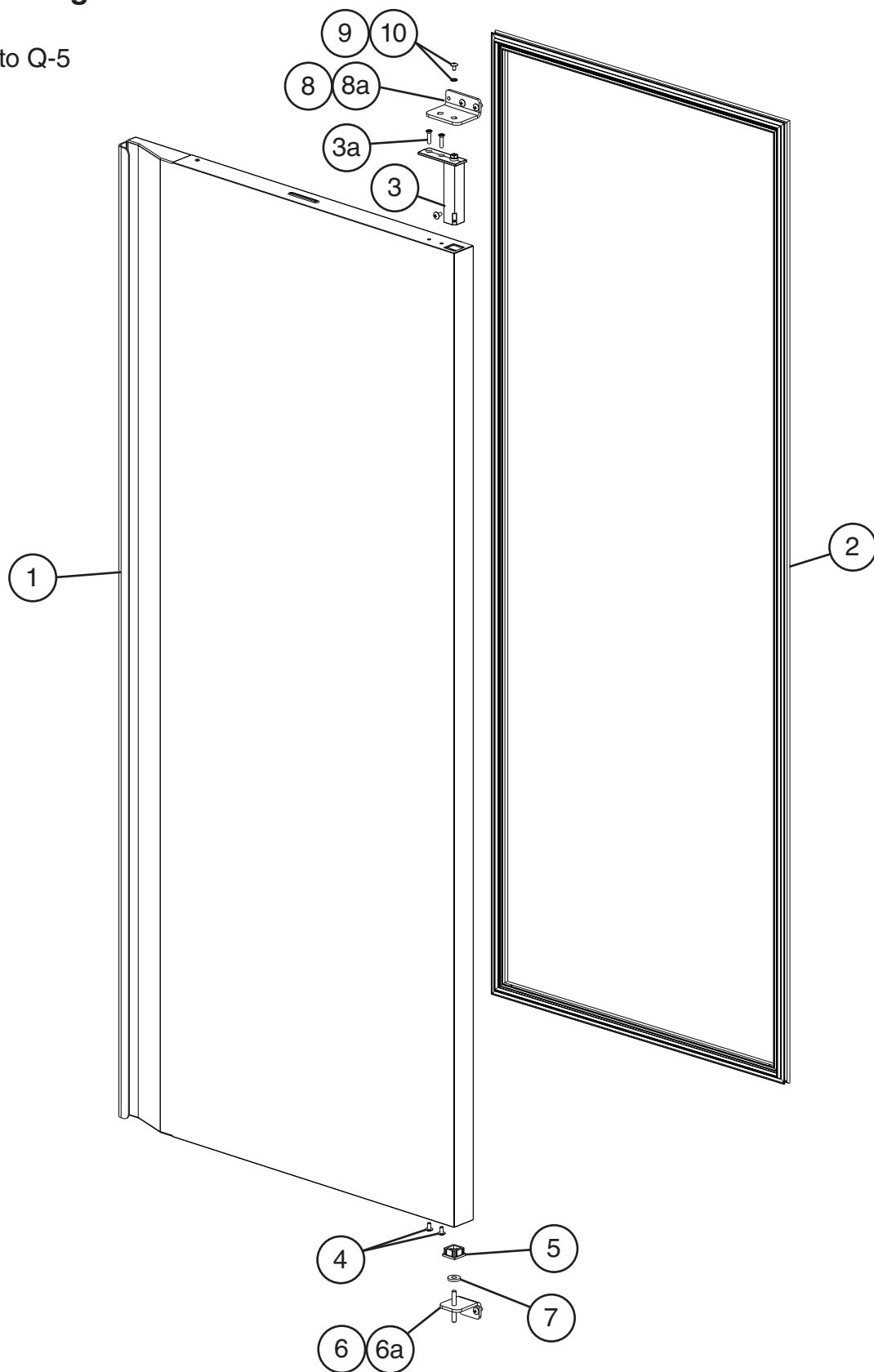

**D. Door-Full Solid
Left Hinged
2/2**

H-5 to Q-5

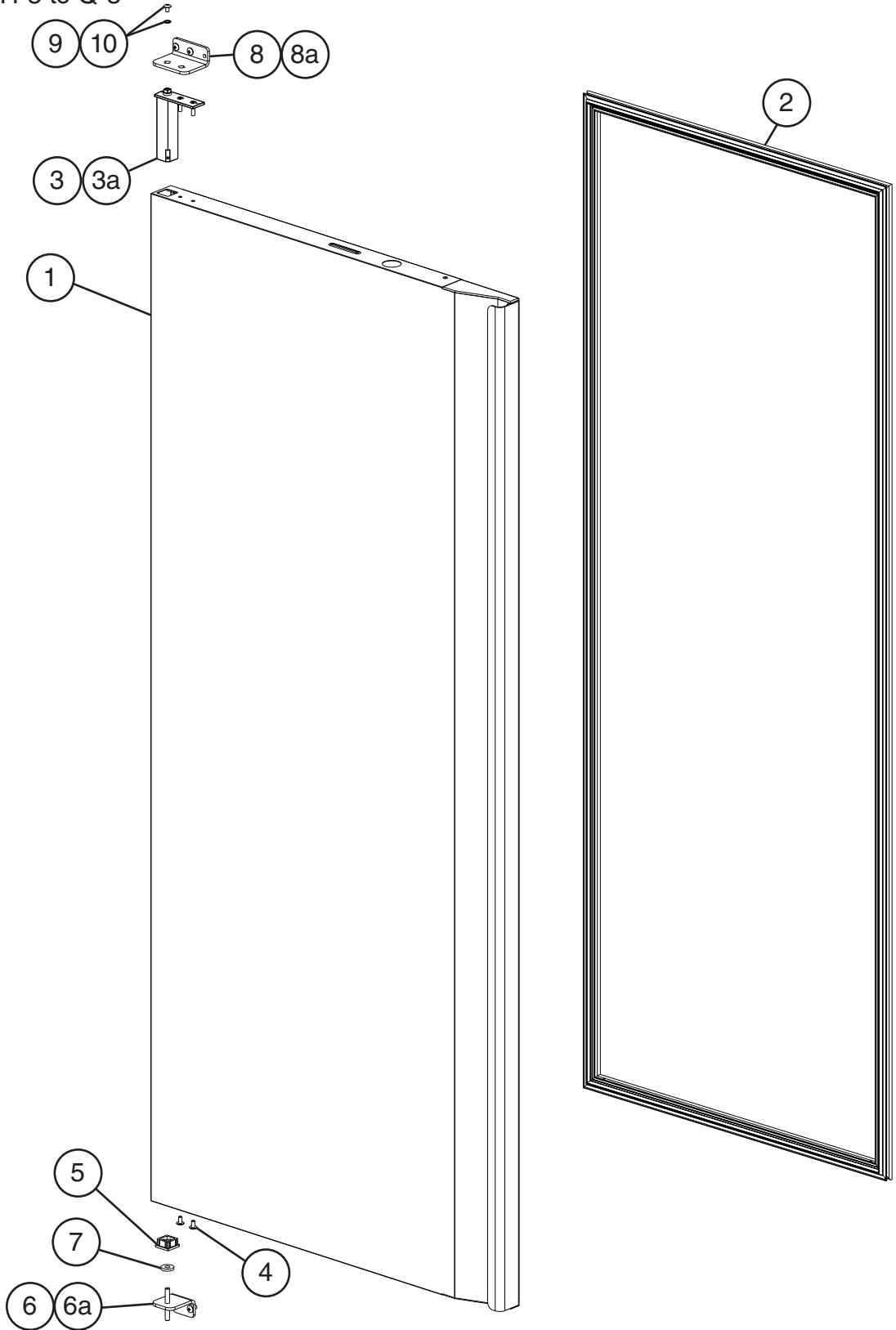

Title: D. Door-Full Solid Model: Full Solid											
Index No.	Description	Material or Model Number	Part Number	H-5 to Q-5	Required Number						
1	Right Door Assembly (includes items 2 through 5)	All Except _2A-FSN	2A7814G01	1							
		_2A-FSN	2B0189G01	1							
	Left Door Assembly (includes items 2 through 5)	All Except _2A-FSN	2A7817G01	1							
		_2A-FSN	2B0191G01	1							
2	Gasket	All Except _2A-FSN	2A5192-23	1							
		_2A-FSN	2A5192-26	1							
3	Spring Cartridge		3A9206-01	1							
3a	Spring Cartridge Screw	5x20, SS	7C42-0520	2							
4	Truss Head Screw (Filler Screw)	5x10, SS	7C32-0510	2							
5	Nylon Bearing		4A5232-01	1							
6	Lower Hinge Bracket		3A9767G01	1							
6a	Truss Head Screw	5x12, SS	7C32-0512	2							
7	Thrust Washer		4A5234-01	1							
8	Upper Hinge Bracket		3A9689-01	1							
8a	Truss Head Screw	5x12, SS	7C32-0512	2							
9	Upper Hinge Bracket Washer		4A5231-01	1							
10	Upper Hinge Bracket Screw		4A5230-01	1							

E. Door-Half Glass Right Hinged 1/2

H-5 to Q-5

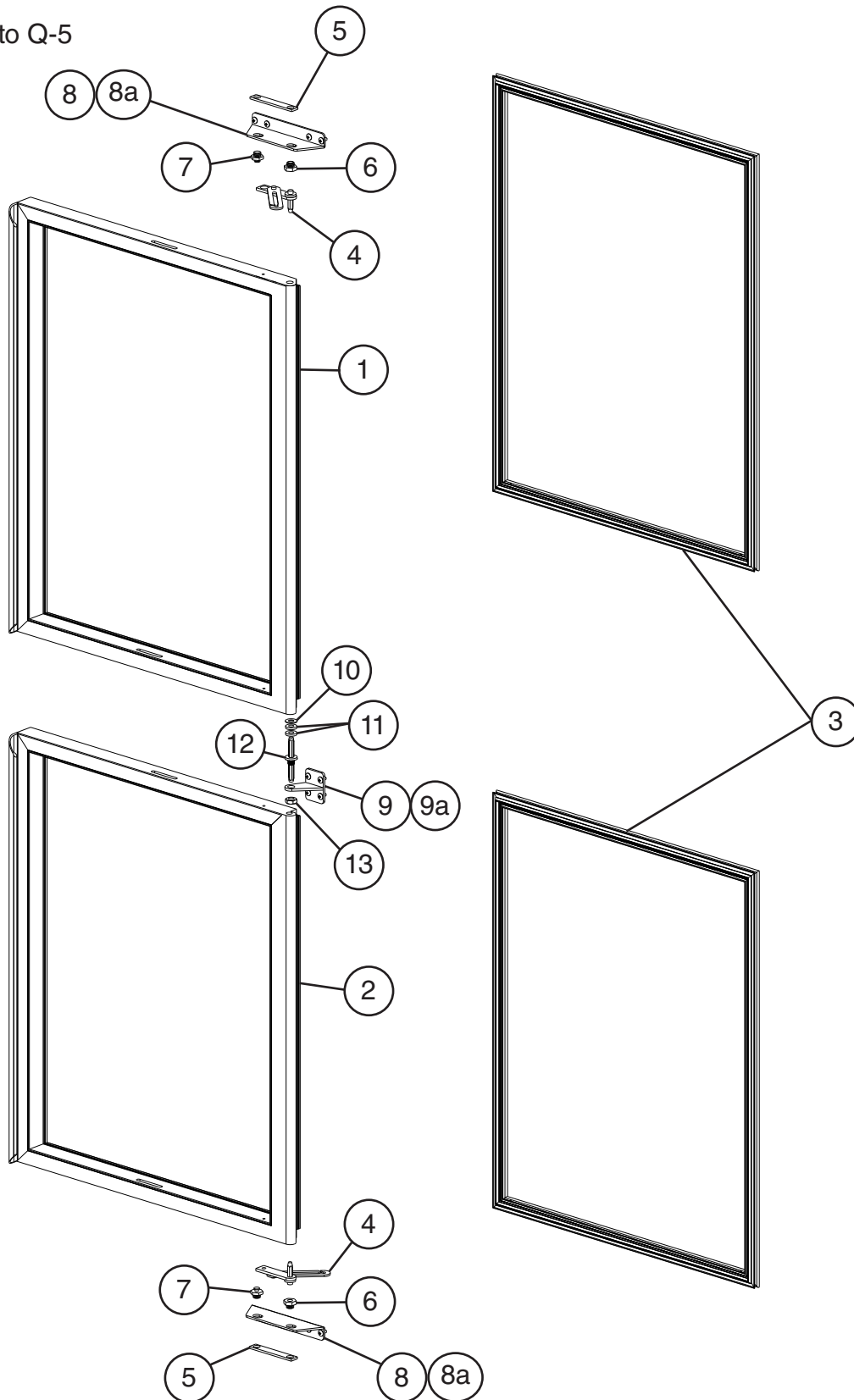

E. Door-Half Glass
Left Hinged
2/2
H-5 to Q-5

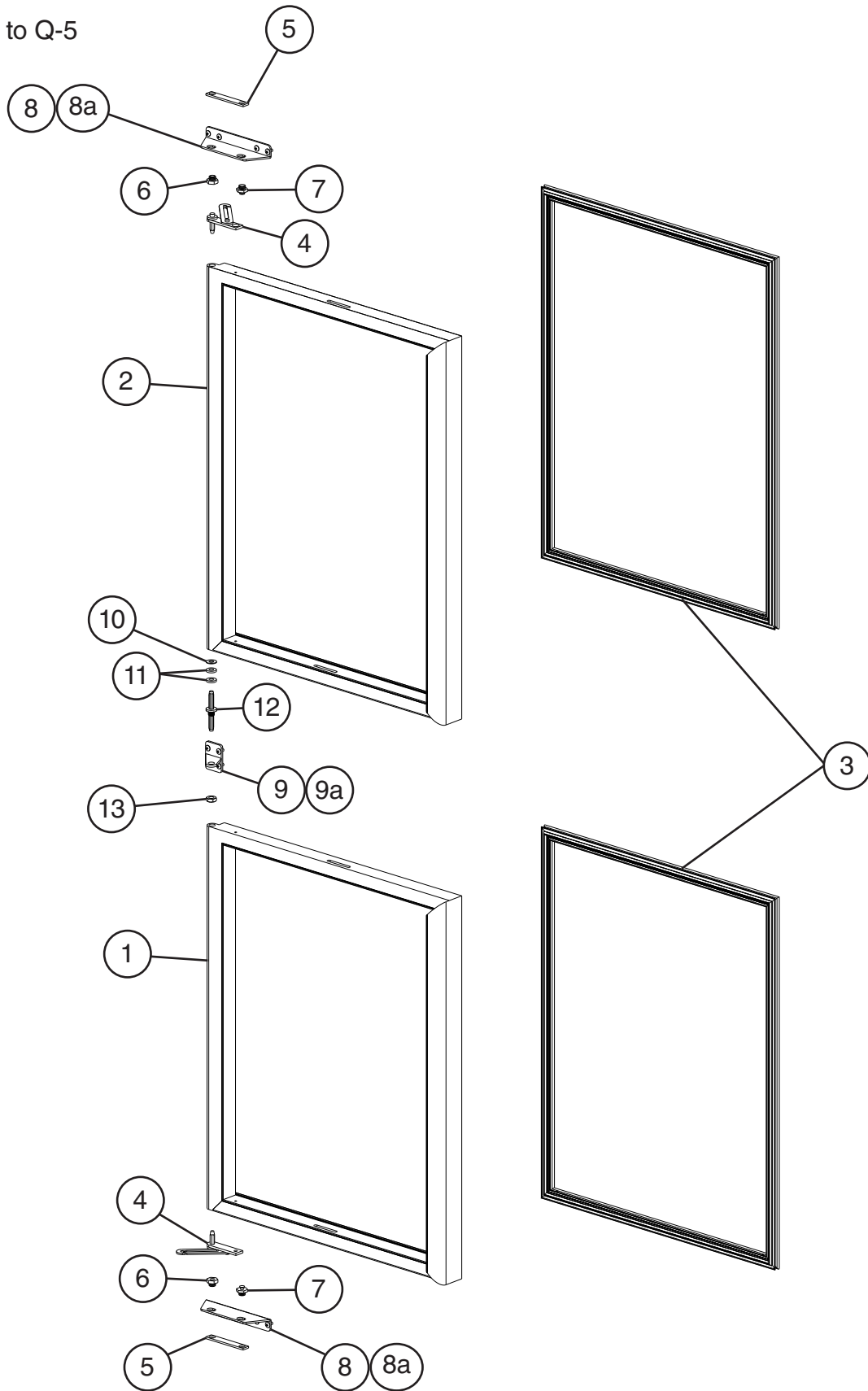

Title: E. Door-Half Glass Model: Half Glass

Index No.	Description	Material or Model Number	Part Number	Required Number											
				H-5 to Q-5											
1	Upper Right/Lower Left Door Assembly (includes half the quantity of items 3 and 4)	R_A-HG	2A8649-01	1											
		F_A-HG	2A8649-02	1											
2	Lower Right/Upper Left Door Assembly (includes half the quantity of items 3 and 4)	R_A-HG	2A8649-03	1											
		F_A-HG	2A8649-04	1											
3	Gasket		4A0808L02	1											
4	Hinge Arm		3A7946-05	2											
5	Backer Plate		3A7946-08	2											
6	Hinge Bushing		3A7946-05	2											
7	Slide Pin		3A7946-11	2											
8	Hinge Bracket		3A9161-01	2											
8a	Truss Head Screw	5x12, SS	7C32-0512	8											
9	Middle Hinge Bracket		4A6223G01	1											
9a	Truss Head Screw	5x12, SS	7C32-0512	4											
10	Middle Hinge Washer		4A6243-01	1											
11	Nylon Washer		3A7946-10	2											
12	Hinge Pin		3A9858-01	1											
13	Hinge Pin Lock Nut		3A7946-05	1											

F. Door-Half Solid Left Hinged 2/2

H-5 to Q-5

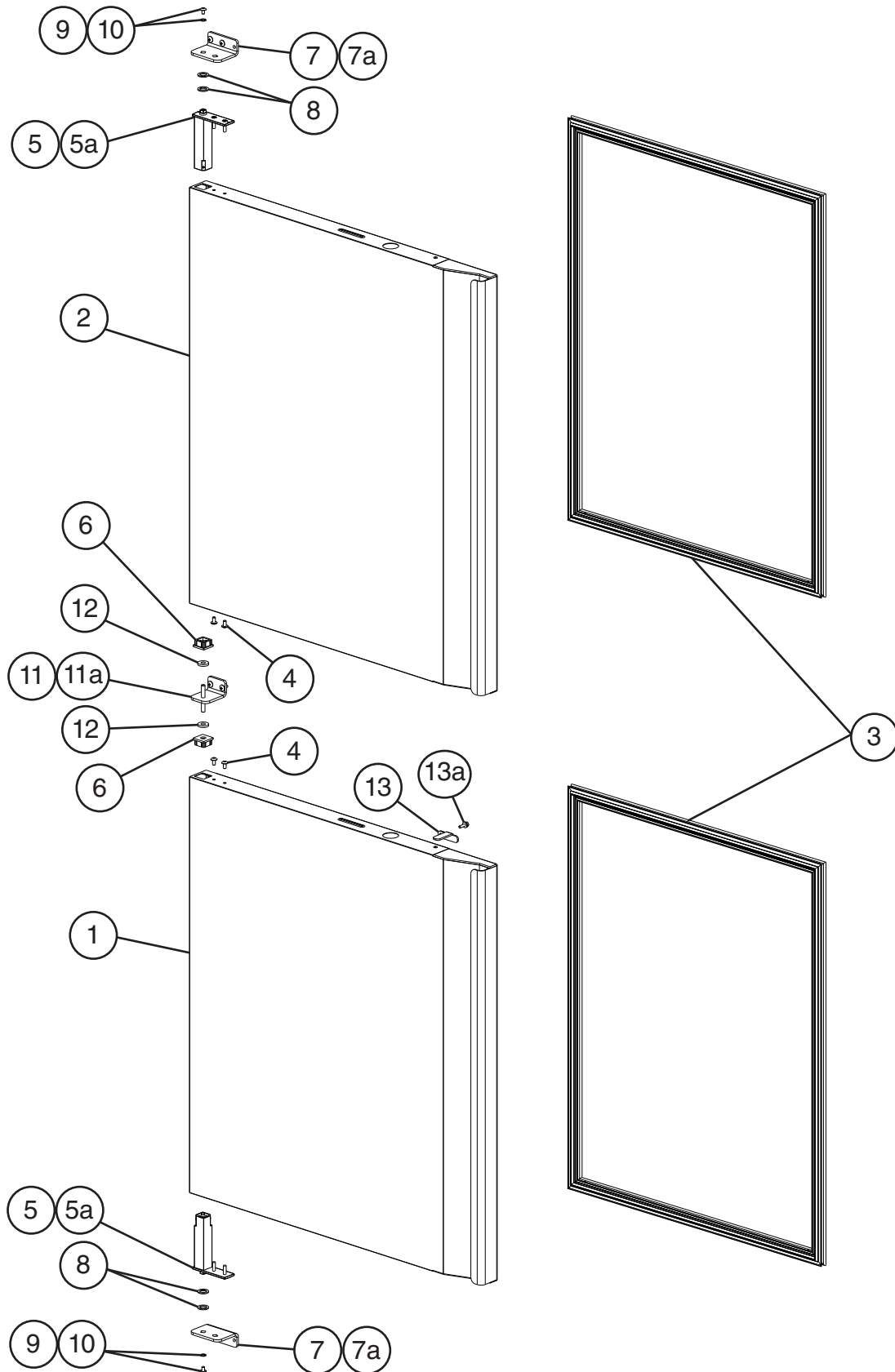

Title: F. Door-Half Solid Model: Half Solid												
Index No.	Description	Material or Model Number	Part Number	Required Number								
				H-5 to Q-5								
1	Upper Right/Lower Left Door Assembly (includes half the quantity of items 3 through 6)		2A7837G01	1								
2	Lower Right/Upper Left Door Assembly (includes half the quantity of items 3 through 6)		2A7838G01	1								
3	Gasket		2A5192-24	2								
4	Truss Head Screw (Filler Screw)	5x10, SS	7C32-0510	4								
5	Spring Cartridge		3A9206-01	2								
5a	Spring Cartridge Screw	5x20, SS	7C42-0520	4								
6	Nylon Bearing		4A5232-01	2								
7	Upper/Lower Hinge Bracket		3A9689-01	2								
7a	Truss Head Screw	5x12, SS	7C32-0512	4								
8	Thrust Washer		4A5233-01	4								
9	Lock Washer		4A5231-01	2								
10	Screw		4A5230-01	2								
11	Middle Hinge Bracket		3A9767G01	1								
11a	Truss Head Screw	5x12, SS	7C32-0512	2								
12	Thrust Washer		4A5234-01	2								
13	Half-Door Lock		4A5249-01	1								
13a	Bolt		7B0230516	1								

G. Accessories & Labels

**_1A-FG/FGCL/FGCR/FS/FSJ/FSL/FSLJ/HG/HS/HSL,
_2A-FG/FGN/FS/HG/HS, _3A-FG/FGCL/FGCR/FS/FSCL/FSCR/HG/HS
H-5 to Q-5**

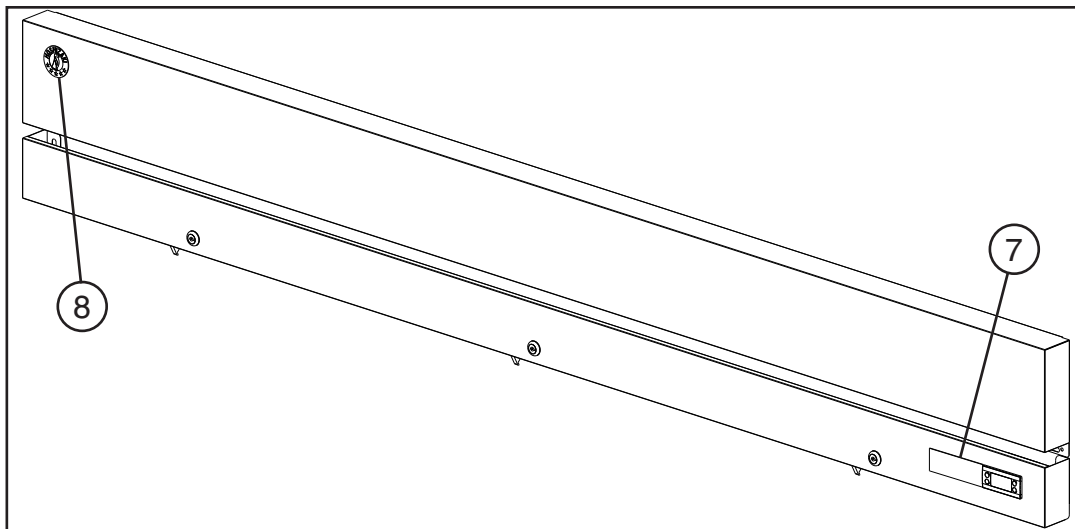
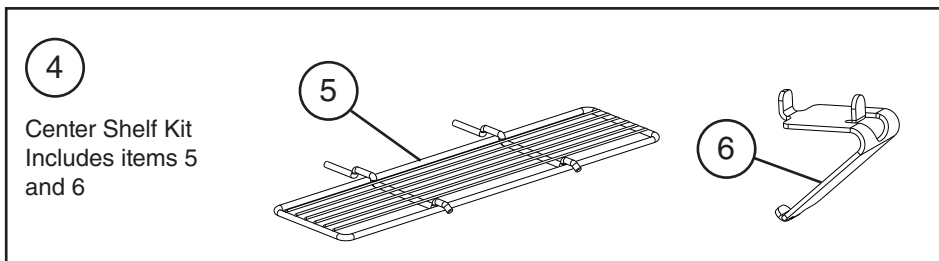
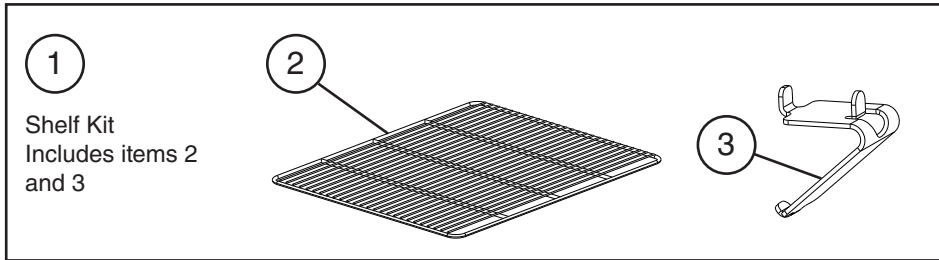

Stem Caster

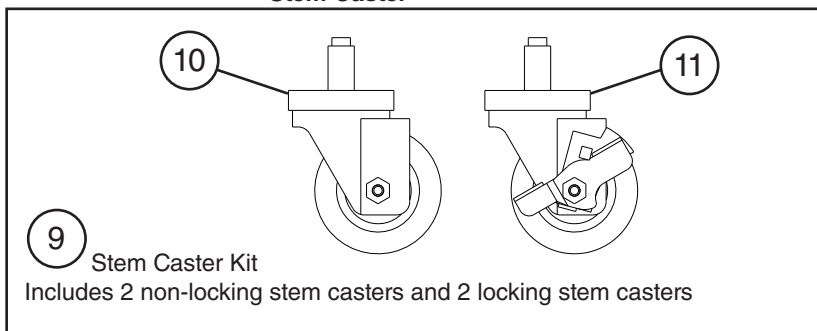

Stem Caster Shim

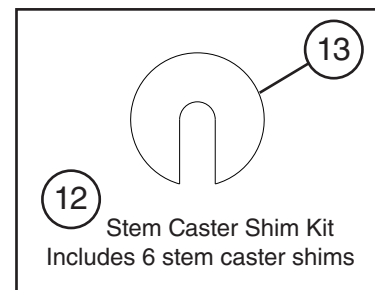

Title: G. Accessories & Labels Model: _1A-FG/FGCL/FGCR/FS/FSJ/FSL/FSLJ/HG/HS/HSL, _2A-FG/FGN/FS/HG/HS, _3A-FG/FGCL/FGCR/FS/FSCR/HG/HS

Index No.	Description	Material or Model Number	Part Number	Required Number							
				H-5 to Q-5							
1	Shelf Kit (3 Pack) (includes items 2 and 3)	_1A-XXXX	3A6902A01 (HS-5053)	1							
	Shelf Kit (3 Pack) (one kit includes half of items 2 and 3)	_2A-XXXX		2							
	Shelf Kit (3 Pack) (one kit includes a third of items 2 and 3)	_3A-XXXX		3							
	Shelf Kit (3 Pack) (one kit includes a sixth of items 2 and 3)	_3A-FGCL/ FGCR/FSCL/ FSCR		6							
2	Shelf	R1A-FGCL/ FGCR	3A6876-03 (HS-5052)	6							
		_1A-XXXX		3							
		_2A-XXXX		6							
		_3A-XXXX		9							
		_3A-FGCL/ FGCR/FSCL/ FSCR		18							
3	Shelf Clip	R1A-FGCL/ FGCR	428957-01	4							
		_1A-XXXX		12							
		_2A-XXXX		24							
		_3A-XXXX		36							
		_3A-FGCL/ FGCR/FSCL/ FSCR		72							
4	Center Shelf Kit (3 Pack) (includes items 5 and 6)	_2A-XXXX	3A4451A01 (HS-3510)	1							
	Center Shelf Kit (3 Pack) (one kit includes half of items 5 and 6)	_3A-XXXX	3A9920A01 (HS-5389)	2							
	Center Shelf Kit (3 Pack) (one kit includes fourth of items 5 and 6)	_3A-FGCL/ FGCR/FSCL/ FSCR		4							
5	Center Shelf	_2A-XXXX	2A1579-01 (HS-3509)	3							
		_3A-XXXX	2A8875-01 (HS-5388)	6							
		_3A-FGCL/ FGCR/FSCL/ FSCR		12							
6	Shelf Clip	_2A-XXXX	428957-01	3							
		_3A-XXXX		6							
		_3A-FGCL/ FGCR/FSCL/ FSCR		12							
7	Hoshizaki Label		4A6943-01	1							
8	Penguin Label		475552L02	1							

Title: G. Accessories & Labels Model: _1A-FG/FGCL/FGCR/FS/FSJ/FSL/FSLJ/HG/HS/HSL, _2A-FG/FGN/FS/HG/HS, _3A-FG/FGCL/FGCR/FS/FSC/L/FSCR/HG/HS

Index No.	Description	Material or Model Number	Part Number	Required Number							
				H-5 to Q-5							
Stem Caster											
9	4-inch Stem Caster Pack (includes 1 locking caster and 1 non-locking caster)	_1A-XXXX _2A-XXXX (HS-3546)	4A1347-03	2							
		_3A-XXXX (HS-5474)		4							
10	4" Non-Locking Caster	_1A-XXXX _2A-XXXX	4A1347-01	2							
		_3A-XXXX		4							
11	4" Locking Caster	_1A-XXXX _2A-XXXX	4A1347-02	2							
		_3A-XXXX		4							
12	Stem Caster Shim Kit (includes item 13)	_1A-XXXX _2A-XXXX	HS-3590	1							
		_3A-XXXX		2							
13	Stem Caster Shim	_1A-XXXX _2A-XXXX	4A3658-01	6							
		_3A-XXXX		12							