

JB450DF

GE® 30" Free-Standing Electric Range

Dimensions and Installation Information (in inches)

Receptacle Locations

Locally approved flexible service cord or conduit must be used because terminals are not accessible after range installation. See shaded area in drawing for location of electrical outlet box. Recommended outlet locations allow range to be installed directly against wall.

Note: This appliance has been approved for 0" spacing to adjacent surfaces above the cooktop. However, a 6" minimum spacing to surfaces less than 15" above the cooktop and adjacent cabinet is recommended to reduce exposure to steam, grease splatter and heat.

Installation Information: Before installing, consult installation instructions for current dimensional data and additional requirements.

KW Rating	
240V	9.8
208V	7.4
Breaker Size	
240V	40 Amps†
208V	40 Amps†

†**Note:** Check local codes for required breaker size.

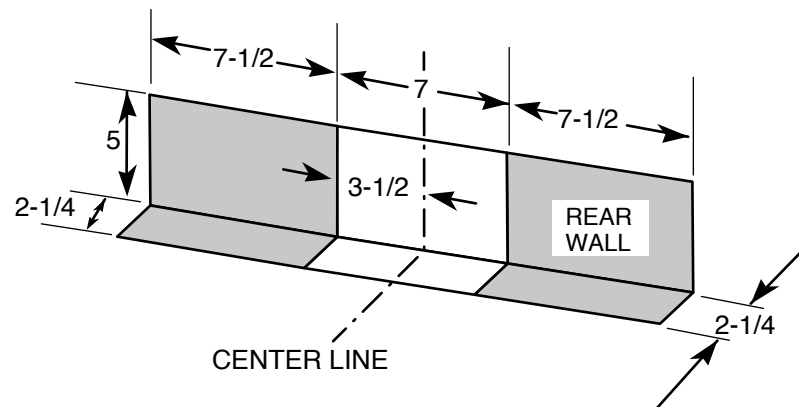
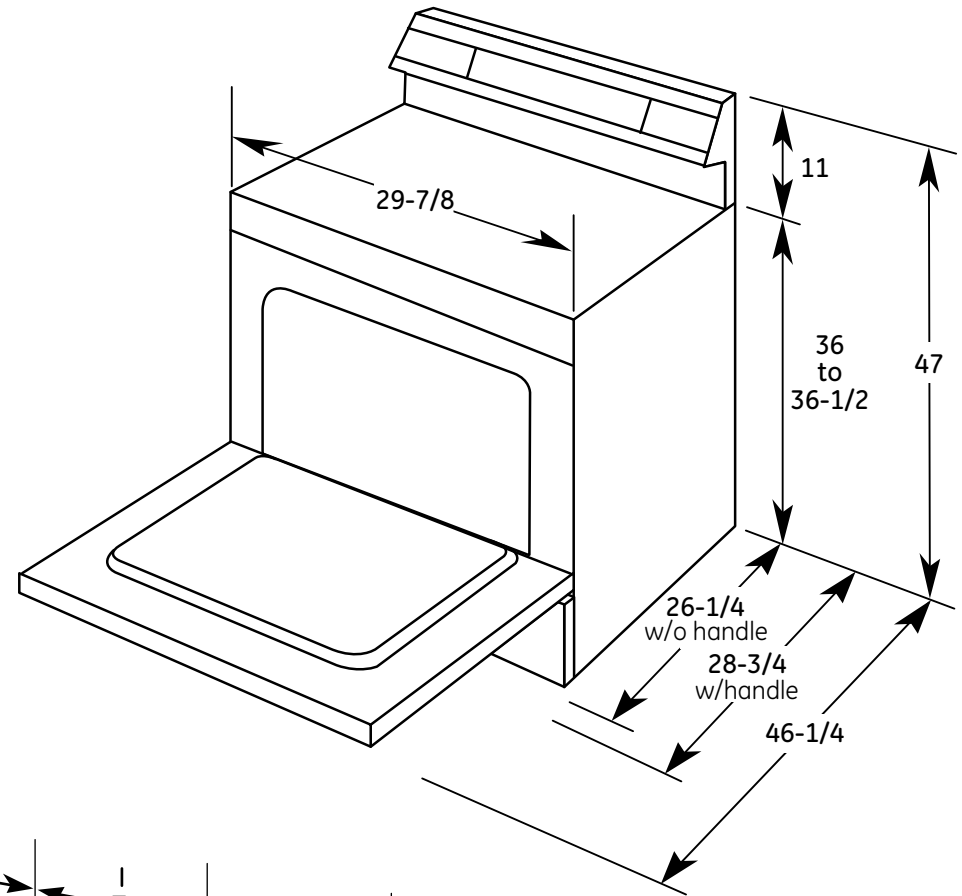

For answers to your Monogram® or GE® appliance questions, visit our website at geappliances.com or call GE Answer Center® service, 800.626.2000.



*ADA qualified based on Uniform Federal Accessibility Standards



All GE ranges are equipped with an Anti-Tip device. The installation of this device is an important, required step in the installation of the range.



Listed by Underwriters Laboratories

JB450DF

GE® 30" Free-Standing Electric Range

Features and Benefits

- Upfront Controls - Minimize need to reach
- 5.0 cu. ft. Oven Capacity - Cook more dishes at once
- Self-Clean Oven - Cleans the oven cavity without the need for scrubbing
- Coil Heating Elements - Provide even heat and easy cleanup
- Dual Element Bake - Upper and lower elements produce even heat and great results
- Removable Full-Width Storage Drawer - Store cookware or kitchen accessories
- Model JB450DFWW – White on white
- Model JB450DFCC – Bisque on bisque
- Model JB450DFBB – Black on black



imagination at work