

ZLINE

ATTAINABLE LUXURY[®]

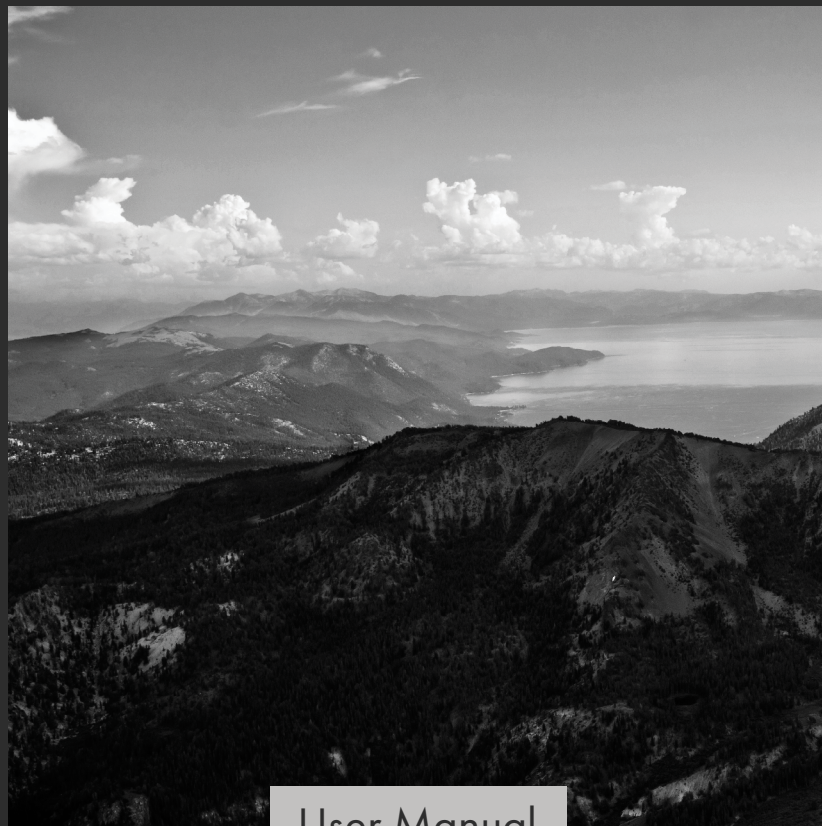

User Manual

INDUCTION RANGES MINR & SINR MODELS

zlinekitchen.com



ZLINE Kitchen and Bath provides Attainable Luxury, where the kitchen and bath of your dreams is never out of reach. Through our unique designs and unparalleled quality, we're dedicated to providing you an elevated experience in the heart of your home. With an endless selection of features and finishes, our inspiration is your reality.

ZLINE
ATTAINABLE LUXURY®



ZLINE is fueled by a passion for innovation—a relentless pursuit of bringing the highest end luxury designs and professional features into everyone’s homes.

Because we continually strive to improve our products, we may change specifications and designs without prior notice.

Scan the QR code to view the most up-to-date version of the Installation Manual and User Manual.

⚠ WARNING: This product can expose you to chemicals including nickel, which is known to the State of California to cause cancer. For more information, go to www.P65Warnings.ca.gov.

TABLE OF CONTENTS

- IMPORTANT SAFETY INSTRUCTIONS..... 1
 - Cooktop Safety 5
 - Tipping Safety 7
 - Surface Burner Safety 9
 - Cooking Safety. 10
 - Cookware Requirements for Induction Cooktops. 11

- OPERATION..... 14
 - Cooktop Specifications 14
 - Cooktop Operation 17
 - Power Management 20
 - Oven Operation 21

- CARE AND MAINTENANCE 26
 - Replacing the Oven Lights 26
 - Cleaning Your Range 27

- TROUBLESHOOTING 30

- WARRANTY 34

IMPORTANT SAFETY INSTRUCTIONS



WARNING:
WARNING

Never Operate the Top Surface Cooking Section of this Appliance Unattended.

- Failure to follow this warning statement could result in fire, explosion, or burn hazard that could cause property damage, personal injury, or death.
- If a fire should occur, keep away from the appliance and immediately call your fire department. **DO NOT ATTEMPT TO EXTINGUISH AN OIL/GREASE FIRE WITH WATER.**



ATTENTION:
WARNING

Ne faites jamais fonctionner la surface de cuisson, sur le dessus de cet appareil, sans surveillance.

- Le non-respect de cette mise en garde pourrait entraîner un incendie, une explosion ou un risque de brûlure et ainsi causer des dommages matériels, des blessures ou la mort.
- Si l'appareil prend feu, tenez-vous à l'écart et appelez immédiatement votre service des incendies. **NE TENTEZ JAMAIS D'ÉTEINDRE UN FEU DE GRAISSE OU D'HUILE EN L'ASPERGEANT D'EAU.**

IMPORTANT SAFETY INSTRUCTIONS

- **NOTE:** This equipment has been tested and found to comply with the limits for a Class B digital device, pursuant to part 15 of the FCC Rules. These limits are designed to provide reasonable protection against harmful interference in a residential installation. This equipment generates, uses and can radiate radio frequency energy and, if not installed and used in accordance with the instructions, may cause harmful interference to radio communications. However, there is no guarantee that interference will not occur in a particular installation. If this equipment does cause harmful interference to radio or television reception, which can be determined by turning the equipment off and on, the user is encouraged to try to correct the interference by one or more of the following measures:
 - Reorient or relocate the receiving antenna.
 - Increase the separation between the equipment and receiver.
 - Connect the equipment into an outlet on a circuit different from that to which the receiver is connected.
 - Consult the dealer or an experienced radio/TV technician for help.

IMPORTANT SAFETY INSTRUCTIONS

FCC DECLARATION OF CONFORMITY	
Unique Identifier	
Product Description	ZLINE Induction Range
Model Number	MINR24-A1, MINR30-A1, MINR36-A1
	SINR24-A1, SINR30-A1, SINR36-A1
Trade Name	ZLINE
FCC Compliance Statement	
This device complies with part 15 of the FCC Rules. Operation is subject to the following two conditions: (1) This device may not cause harmful interference, and (2) this device must accept any interference received, including interference that may cause undesired operation.	
This device complies with Part 18 of the FCC Rules.	
Responsible Party – U.S. Contact Information	
Company:	ZLINE Kitchen and Bath, LLC
Address:	350 Parr Circle Reno, NV 89509
Telephone or internet contact information:	<ul style="list-style-type: none"> • 1-614-777-5004 • contact@zlinekitchen.com

IMPORTANT SAFETY INSTRUCTIONS

- Before beginning installation, please read and follow these important instructions for the safety of your home and the people living in it.
- The manufacturer will not be responsible for any damage to property or to persons caused by incorrect installation, improper use of the appliance, or failure to heed the warnings listed.
- The manufacturer reserves the right to make changes to its products when considered necessary and useful, without affecting the essential safety and operating characteristics.
- This appliance has been designed for non-commercial, domestic use only.
- Please observe all local, state, and national codes and ordinances. Please ensure the range is properly grounded. The plug should always be accessible.
- The installer should leave these instructions with the consumer who should retain for local inspectors' use and for future reference.
- In Massachusetts, installation must be performed by a Massachusetts licensed installer.
- This manual does not cover all possible conditions that may occur during installation and/or operation. Always contact a qualified service technician or the manufacturer about problems you may not understand.
- The installation of appliance designed for manufactured (mobile) home installation must conform with the Manufactured Home Construction and Safety Standard, Title 24CFR, Part 3280 [formerly the Federal Standard for Mobile Home Construction and Safety, Title 24, HUD (Part280)] or with local codes where applicable.

IMPORTANT SAFETY ALERTS



DANGER: When you see this symbol in the instructions, it indicates a hazardous situation which, if not avoided, could result in death or serious injury.



WARNING: When you see this symbol in the instructions, it indicates a hazardous situation which, if not avoided, could result in minor or moderate injury.

IMPORTANT SAFETY INSTRUCTIONS



WARNING

Installation and service on this product must be performed by a qualified installer or servicer. Ask the manufacturer to recommend a qualified technician and authorized repair service in your area.

- Do not repair or replace any part of the appliance unless specifically recommended in this manual. All other servicing should be done only by a qualified technician. This may reduce the risk of personal injury and damage to the appliance.



DANGER

Always disconnect power when servicing this product, especially for larger-scale repairs impacting important appliance functionality; failure to do so increases the risk of fire, explosion, injury, or death.



DANGER

COOKTOP SAFETY

- Children should not be left alone or unattended in the area where the appliance is in use. Do not allow children to climb, play, sit, or stand on or around any part of the appliance. Children climbing on the appliance to reach items could be seriously burned or injured.
- **DO NOT TOUCH THE COOKING SURFACE, BURNERS, OR ANY AREAS NEAR THEM.** Cooking surface or other parts of the range may be hot.
- Areas near cooking surface or throughout the appliance may become hot enough to cause burns. During and after use, do not touch, or let clothing or other flammable materials touch, these areas until they have had sufficient time to cool.
- Do not wear loose-fitting or hanging garments while using the appliance. Do not let clothing or other flammable materials contact hot surfaces.
- Smother grease fires with a pan lid, or use baking soda, a dry chemical, or foam-type extinguisher. Use an extinguisher **ONLY** if:
 - You have a Class A, B, or C extinguisher and you know how to operate it.
 - The fire is small and contained in the area where it is started.
 - The fire department is being/has been called.
 - You can fight the fire with your back to an exit.
- When heating fat or grease, watch it closely. Fat or grease may catch fire if allowed to become too hot.

IMPORTANT SAFETY INSTRUCTIONS

- Use only dry potholders and oven mitts. Moist or damp potholders on hot surfaces may result in burns from steam. Do not let potholders touch hot heating elements or burners. Do not use a towel or other bulky cloth instead of a potholder.
- Do not heat unopened food containers. Buildup of pressure may cause the container to burst and result in injury.
- Stepping, leaning, or sitting on this appliance can result in serious injuries and also damage the appliance.
- Know which knob controls which surface burner. Visually check that the element is on.
- Clean the appliance regularly to keep all parts free of grease that could catch fire. Exhaust fan ventilation range hoods and grease filters should be kept clean. Do not allow grease to accumulate on hoods or filters. Greasy deposits in the fan could catch fire.
- When cooking food, turn the hood fan on. Refer to hood manufacturer's instructions for cleaning and operation.
- Pot/pan handles should be turned inward and not extend over cooking surface. To reduce the risk of burns, ignition of flammable materials, and spillage due to unintentional contact with the pot/pan, the handle of the utensil should be positioned so that it is turned inward, and does not extend over adjacent cooking surface.
- Do not use aluminum foil to line any part of the appliance. Use aluminum foil only to cover food during cooking. Improper use of these liners may result in risk of electric shock or fire. Use of aluminum foil on any part of the range may void the manufacturer's warranty.





WARNING Never leave cooking surface unattended. Boilovers cause smoke and greasy spillovers that may ignite, or a pan that has boiled dry may melt.

- Do not use decorative surface burner covers. If a burner is accidentally turned on, the decorative cover will become hot and possibly melt. You will not be able to see that the burner is on. Burns will occur if the hot covers are touched. Damage may also be done to the appliance or burners because the covers may cause overheating. Air will be blocked from the burner and cause problems.
- Always use proper pot/pan and cookware sizes. This appliance is equipped with surface units of different sizes. Select cookware with flat bottoms large enough to cover the surface unit.

IMPORTANT SAFETY INSTRUCTIONS



TIPPING SAFETY

	<p style="text-align: center;"> TIP-OVER HAZARD WARNING</p> <ul style="list-style-type: none">• A child or adult can tip the range and be killed.• Install anti-tip device to range and/or structure per installation instructions.• Engage the range to the anti-tip device installed to the structure.• Re engage anti-tip device if range is moved.• Failure to follow these instructions can result in death or serious burns to children and adults.
---	---

- Ensure the anti-tip device is re-engaged when the range is moved by following the same steps outlined on this page and in the Installation Manual.
- Carefully pull on the range from the rear. If the brackets are installed correctly, the range will not tip more than 4" (102 mm) from the wall. If it tips forward more than 4" (102 mm), the anti-tip device has not been installed correctly.



DO NOT TIP THE RANGE MORE THAN 4" (102 mm) FROM THE WALL AS IT COULD TIP OVER AND CAUSE INJURY.

- Never completely remove the leveling legs or the range may not be secured to the anti-tip device properly. NEVER step or sit on the door.
- The range will not tip during normal use. However, without a properly fastened anti-tip bracket, the range can tip if too much force or weight is applied to the open door.

IMPORTANT SAFETY INSTRUCTIONS

STORAGE AND FIRE SAFETY

- Items of interest to children should not be placed in cabinets above the appliance or on the steel back splash vent at the back the range. Children climbing on the appliance to reach items could be seriously injured.
- DO NOT leave children alone or unattended when the appliance is hot or in operation, even if the burners and oven have been off for several minutes. The unit's door, knobs, and cooktop may still have residual heat, and children could be seriously burned.
- DO NOT let anyone climb, stand, or hang on the unit. They could damage the range or cause it to tip over which could result in severe personal injury.
- NEVER wear loose fitting or hanging garments while using the range. Be careful when reaching for items placed in cabinets over the appliance. Flammable material could be ignited if it contacts hot surfaces and may cause severe burns.
- DO NOT place flammable materials in the oven or anywhere near the range.
- DO NOT place or use combustible materials such as gasoline or other flammable vapors and liquids in the vicinity of this or any other appliance.
- DO NOT store cooking grease or other flammable materials in or near the appliance.



Never leave burners unattended at high heat settings. Boilovers cause smoke and greasy spillovers that may ignite, or a pan that has boiled dry may melt. DO NOT ATTEMPT TO EXTINGUISH AN OIL/GREASE FIRE WITH WATER.

- If a grease fire occurs, never touch a flaming pan. Immediately turn the controls off. Smother a flaming pan on a surface burner by covering the pan completely with a well-fitting lid, cookie sheet, or flat tray.
- A grease fire can also be put out by covering it with baking soda or, if available, by using a multi-purpose dry chemical or foam-type fire extinguisher.
- Flames inside the oven can be smothered completely by closing the oven door and turning controls to OFF, or by using a fire extinguisher.
- Allow the surfaces to completely cool before touching them.
- Make sure your appliance is properly installed and grounded by a qualified installer, according to instructions explained in the Installation Manual. Any adjustment and service should be performed only by qualified range installers or service technicians.
- To prevent poor air circulation, place the appliance out of kitchen traffic path and out of drafty locations.

IMPORTANT SAFETY INSTRUCTIONS

- DO NOT attempt to repair or replace any part of your appliance unless it is specifically mentioned in this manual. All other service should be referred to a qualified technician.
- Make sure all packaging materials are removed — including the plastic zip ties securing the oven racks during shipping — from the appliance before operating it to prevent fire or smoke damage should the packaging material ignite.
- Use the appliance only for cooking tasks as outlined in this manual. When using the appliance, do not touch the burner bases or any other parts in proximity to the heat. These components may be hot enough to cause burns.
- During and after use, do not touch interior surfaces of the oven until cool.



SURFACE BURNER SAFETY

WARNING

- NEVER leave the cooking surface unattended, especially at high settings.
- DO NOT use pots/pans that are unstable or easily tipped. Select cookware with flat bottoms that are large enough to cover burners. To avoid spillovers, make sure cookware is large enough to contain the food properly. This will save cleaning time and prevent hazardous accumulations of food that could ignite.
- Pot/pan handles should be turned inward and not extend over adjacent cooking surface. To reduce the risk of burns, ignition of flammable materials, and spillage, handles of pots and pans should be positioned so that they are turned inward and do not extend over adjacent cooking surface.
- Use only dry pot holders or oven mitts—moist or damp pot holders on hot surfaces may result in burns from steam. DO NOT let pot holders come near open burners when lifting cookware. DO NOT use a towel or other bulky cloth instead of a pot holder.
- Do not use decorative surface burner covers. If a burner is accidentally turned on, the decorative cover will become hot and possibly melt. You will not be able to see that the burner is on. Burns will occur if the hot covers are touched.



WARNING

NEVER place any items on the cooktop or the back splash of the range. Hot air from the vent may ignite flammable items and will increase pressure in closed containers, which may cause them to burst and increase risk of injury.

IMPORTANT SAFETY INSTRUCTIONS



WARNING

COOKING SAFETY

Before cooking in your new range, we recommend setting the oven to 400 °F (200 °C) for 1 hour, then setting the oven to broil for 1 hour. There may be a smell and/or smoke — this is normal when the range is first heated as manufacturing oils burn off. Ensure the room where the range is installed is well ventilated by keeping air intakes open and/or by operating a range hood above the unit. After the oven cools, wipe it out with hot water and a kitchen-safe cleaner. We also recommend cleaning the racks and shelves before use.

- Carefully watch foods being fried at high settings and always heat fat slowly.
- If frying combinations of oils and fats, stir together before heating, and use a deep fat thermometer if possible to prevent overheating fat beyond the smoking point.
- Use the least possible amount of fat for effective shallow or deep-fat frying. Filling the pan too full of fat can cause spillovers when food is added.
- NEVER cook foods directly on the burner without a pot or pan; use proper cookware.

IMPORTANT SAFETY INSTRUCTIONS

COOKWARE REQUIREMENTS FOR INDUCTION COOKTOPS

To ensure optimal performance and safety, only use cookware that meets the following requirements:

1. Material Requirements

- **Magnetic properties required:** Cookware must contain ferromagnetic materials (such as cast iron or magnetic stainless steel). A strong magnet should adhere firmly to the bottom of the cookware.
- **Good thermal conductivity:** Materials should conduct heat evenly for efficient cooking.

2. Bottom Design Requirements

- **Thick, flat bottom:** A thick, flat bottom improves contact with the cooktop and ensures even heating.
- **Avoid honeycomb or textured bottoms:** These reduce surface contact and result in uneven heating.
- **No feet or curved bases:** Cookware must sit flush on the cooktop surface.

3. Cookware Condition

- **Use new or undamaged cookware:** Old or warped pots and pans can reduce performance or damage the cooktop.
- **Inspect regularly:** Replace cookware with dented, bowed, or uneven bottoms.

4. Recommended Cookware Types

- **Best Choice: Cast Iron**
 - **Raw cast iron:** Naturally magnetic and retains heat well.
 - **Enameled cast iron:** Same benefits, with an easier-to-clean coating.
 - **Precision cast iron:** Enhanced durability and surface quality.
- **Other Suitable Types**
 - **Magnetic stainless steel:** Use types such as 430-grade stainless steel made for induction.
 - **Iron or carbon steel pans**
 - **Composite cookware:** Includes cookware with multi-layer magnetic bottoms.
 - **Iron enamel teapots:** Suitable if the base is magnetic and flat.

IMPORTANT SAFETY INSTRUCTIONS

5. Unsuitable Cookware Types

- **Non-Magnetic Materials**
 - Ceramic
 - Glass
 - Aluminum (unless labeled induction-compatible)
 - Copper (unless part of a multi-layer magnetic design)
- **Improper Shapes**
 - Round or curved bottoms
 - Bottoms with legs or feet
 - Warped or dented bases

6. Consequences of Using Improper Cookware

- **Performance Issues**
 - Slow or no heating
 - Uneven heat distribution
 - Reduced energy efficiency
- **User Experience Issues**
 - Unusual buzzing or humming sounds
 - Excessive base temperatures
 - Shortened cooktop or cookware lifespan
- **Safety Risks**
 - Damage to induction cooktop components
 - Poor cooking results or food quality

7. How to Test Cookware

- **Magnet Test**
 - Place a magnet at the bottom of the cookware.
 - If it sticks firmly, the cookware is compatible.
 - Weak or no attraction indicates it is unsuitable.
- **Flatness Test**
 - Place cookware on a level surface.
 - If it rocks or does not sit flush, it should not be used.

IMPORTANT SAFETY INSTRUCTIONS

8. Usage and Maintenance Tips

• Daily Use

- Always place cookware in the center of the cooking zone.
- Keep bottoms clean and dry.
- Avoid operating the cooktop without food or liquid inside cookware (dry heating).

• Maintenance

- Regularly check the cookware's base for warping or damage.
- Avoid scraping the bottom with sharp tools.
- Replace cookware if magnetic attraction weakens or the bottom becomes uneven.

9. Best Practices and Precautions

- Use thick-bottomed cast iron cookware for best performance.
- Confirm magnetic compatibility before use.
- Avoid cookware with warped, dented, or protruding bottoms.
- Refer to cookware manufacturer instructions when unsure.

NOTE: Proper cookware selection is critical for achieving efficient, safe, and enjoyable cooking results on induction cooktops.

OPERATION

COOKTOP SPECIFICATIONS

24" (610 mm)

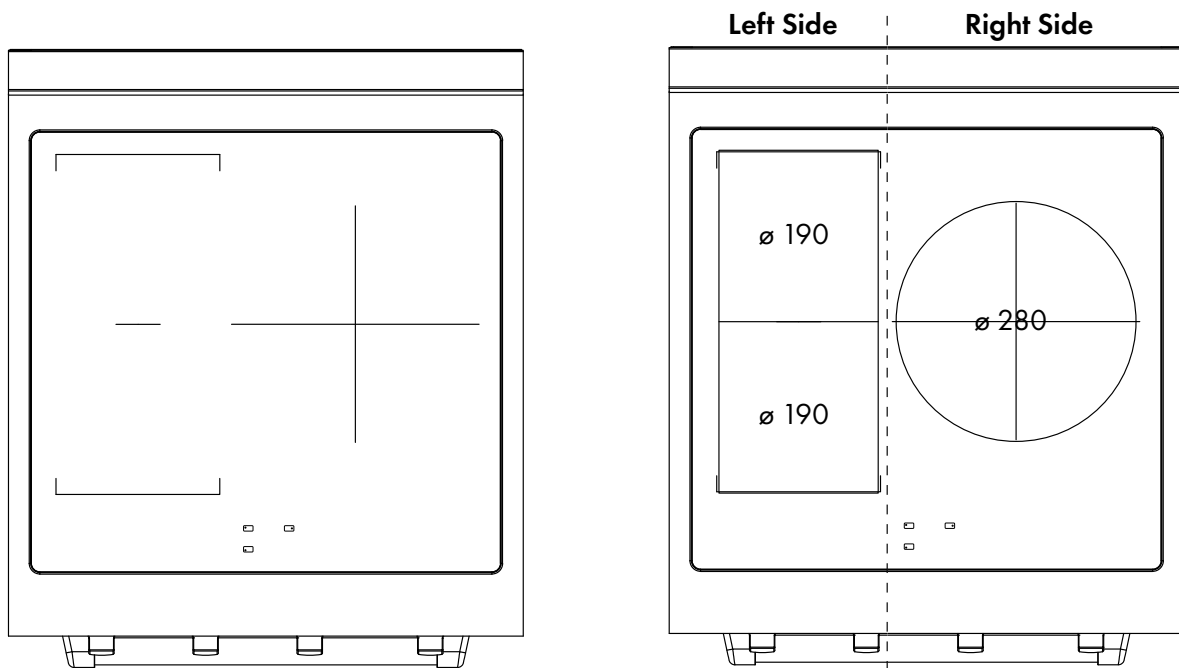

24" (610 mm)	Left Side			Right Side
	Bridge	Ø190	Ø190	Ø280
Zones				
9 Levels	3000 W	2000 W	2000 W	3000 W
Power Boost	3600 W	2600 W	2600 W	3600 W
Level 9 + 9	-	4000 W		-
Maximum Cooktop Power	7600 W			
Maximum power of induction when the oven is working	7600 W			
NOTE	A maximum of 2 power boosts			

OPERATION

30" (762 mm)

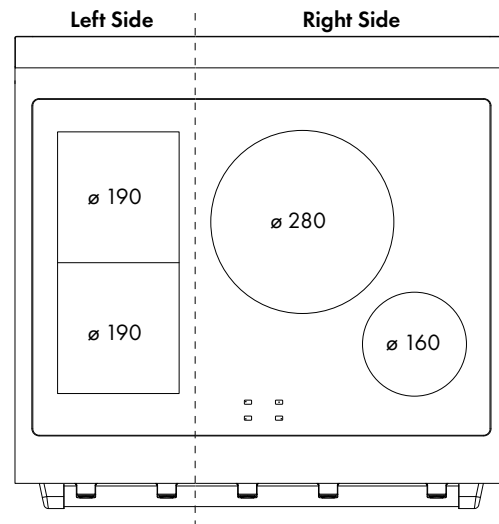
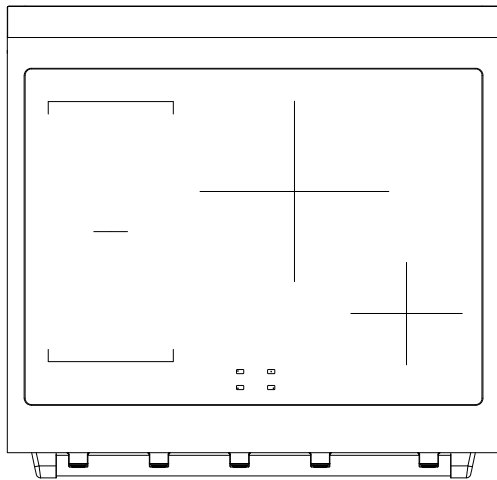

30" (762 mm)	Left Side			Right Side	
Zones	Bridge	Ø190	Ø190	Ø280	Ø160
9 Levels	3000 W	2000 W	2000 W	3000 W	1200 W
Power Boost	3600 W	2600 W	2600 W	3600 W	1500 W
Level 9 + 9	-	4000 W		-	
Maximum Cooktop Power	7600 W				
Maximum power of induction when the oven is working	7600 W				
NOTE	One Power Boost per side (left and right)				

OPERATION

36" (914 mm)

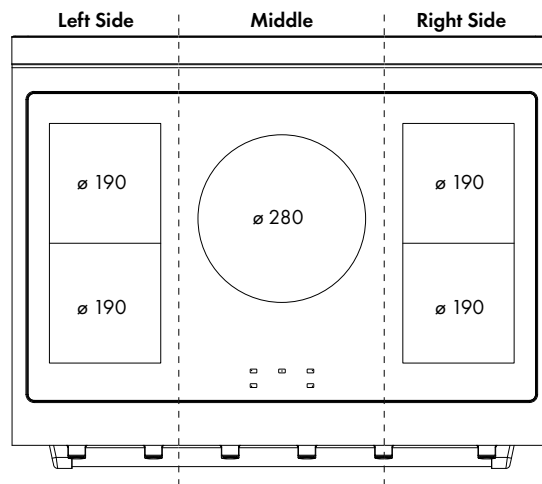
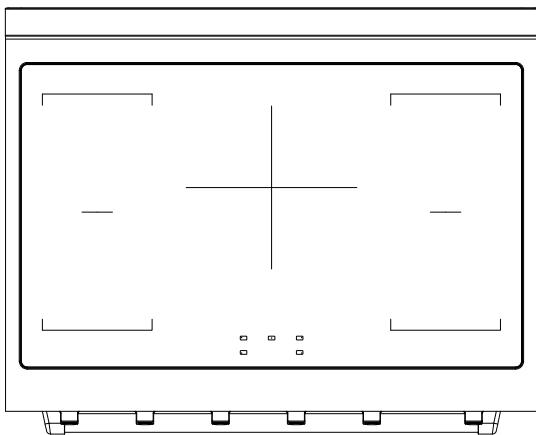

36" (914 mm)	Left Side			Middle	Right Side		
Zones	Bridge	Ø190	Ø190	Ø280	Bridge	Ø190	Ø190
9 Levels	3000 W	2000 W	2000 W	3000 W	3000 W	2000 W	2000 W
Power Boost	3600 W	2600 W	2600 W	3600 W	3600 W	2600 W	2600 W
Level 9 + 9	-	4000 W		-	-	4000 W	
Maximum Cooktop Power	11600 W						
Maximum power of induction when the oven is working	When the oven is working, the induction power is reduced by 3400 W, the maximum induction power becomes 8200 W.						
NOTE	The left side, middle zone, and right side each have one Power Boost.						

OPERATION

COOKTOP OPERATION

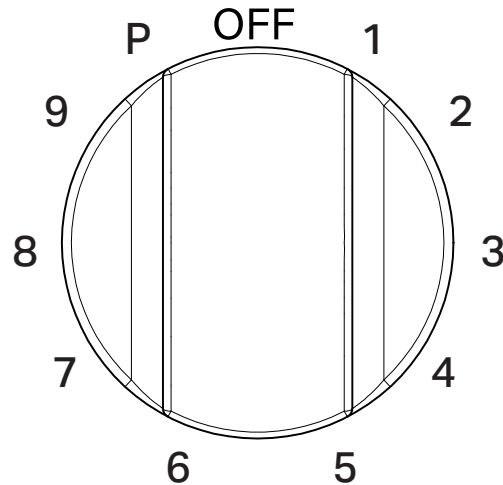

Power Levels (1–9)

Turn the control knob counterclockwise to increase the cooking level from 1 (low) to 9 (high). The display shows the corresponding level.

Simply adjust each knob between the maximum and minimum options for other settings, as referenced below:

HEAT SETTINGS AND SIMPLE COOKING GUIDE	
1	Melting large quantities.
2–3	Low-temperature frying, simmering large quantities, heating milk, cream sauces, gravies.
4–6	Sautéing and browning, braising, pan-frying, maintaining slow boil on large quantities.
7–9	High-temperature frying, pan boiling, maintaining slow boil on large quantities.
P (Boost)	Boiling liquid quickly, deep frying.

Power Boost (“P”)

Rotate the knob past level 9 to activate Power Boost (“P”).

- Power Boost runs for 10 minutes and then automatically reduces to level 9.
- The knob will rebound slightly when moved into the “P” position.

OPERATION

ACCENT LIGHTS

MINR SERIES RANGES

What the accent light button does

- OFF (button not illuminated): All LED knob rings are OFF, even if a burner or the oven is on.
- ON (button illuminated):
 - All knob rings glow DIM as ambient/accent lighting.
 - Any active control (burner ON or oven ON) switches its ring to BRIGHT.
 - Non-active controls remain DIM.

How to use

1. To turn accent lighting ON/OFF:
 - Press accent light once to enable ambient lighting (DIM rings).
 - Press again to disable ambient lighting (all rings OFF).
2. To operate a burner or the oven:
 - When accent lighting is ON, the ring for any engaged knob (burner ON/oven ON) turns BRIGHT; others stay DIM.
 - When accent lighting is OFF, rings do not illuminate, regardless of knob position.

Indicator behavior summary

- Accent Light OFF + Burner/Oven OFF: all LED rings OFF
- Accent Light OFF + Burner/Oven ON: all LED rings OFF
- Accent Light ON + Burner/Oven OFF: all LED rings DIM
- Accent Light ON + Burner/Oven ON: the corresponding LED ring is BRIGHT; others not in use are DIM.

NOTE:

- The accent light feature is decorative and not a safety indicator. Always verify burner/oven status by knob position and display/markings.
- If rings do not illuminate when expected, confirm the accent light button is ON.
- Brightness levels are fixed (DIM/BRIGHT) and not user-adjustable.

OPERATION

Startup Requirement

After switching the cooktop ON, if the knob is not at OFF, it must first be turned to OFF before selecting a cooking level.

Pot Detection

If no cookware is detected, the display shows "  " for that burner. Place suitable induction-compatible cookware to begin cooking.

Hot Surface Indicator

When the cooking surface remains hot, the display shows "  ." Use caution until the indicator disappears.

Knob Error Protection

If a knob malfunctions or disconnects for more than 10 seconds while cooking, the affected burner will shut off automatically.

Bridge Function

The bridge function allows two adjacent cooking zones to operate as a single larger zone.

To activate:

1. Turn both corresponding knobs to "P."
2. Hold for 3 seconds.
3. One zone will display the bridge symbol "  " and the main control knob will display "9."
4. Use the main control knob to adjust the bridge power level.

To deactivate:

Turn the main control knob to OFF.

OPERATION

POWER MANAGEMENT

To protect the electrical system and maintain safe performance, power distribution is automatically managed:

1. Same-Side Limitation

- Total power on one side cannot exceed 4000 W.
- If one burner is set to Power Boost, the other burner on the same side cannot exceed level 7.

2. Different-Side Operation

- Burners on opposite sides may both be set to Power Boost simultaneously.
- Example: On the 24" (610 mm) model, the left burner can use Power Boost while the large right-side burner also operates in Power Boost.

3. Automatic Power Adjustment

- During Power Boost, the cooktop will gradually reduce power as needed to manage temperature.
- After 10 minutes, Power Boost automatically decreases to level 9.
- At level 9, power will reduce slightly every 20 minutes—this is normal operation.

4. Simultaneous Oven Use

- When the oven and cooktop are used at the same time, oven power is maintained first.
- The cooktop will then ensure power delivery to the large burner as a priority.



WARNING

Important Safety Notes

- Always use induction-compatible cookware for proper function.
- Surfaces marked with "H" remain hot to the touch even after cooking.
- Do not rely on Auto Power Management to prevent overheating—always monitor cooking.
- Be sure to place cookware directly on the center of each burner in order to maximize cooking efficiency; see below for more.
- If cooking with a griddle, we recommend using the bridge burners to provide more even heating. Be careful to heat and cool the griddle slowly, as rapid changes in temperature can cause thermal shock and crack the griddle.

OPERATION

OVEN OPERATION

- To turn on the oven, push in the knob and turn counter-clockwise. Once the oven has reached the desired temperature, the white indicator light next to the knob will turn off.
- To activate the Broil function, turn the knob clockwise to Broil. The white indicator light will illuminate once activated.
- There is 1 knob which features minimum and maximum heat settings of 200 °F to 500 °F (93 °C to 260 °C), in addition to Broil.

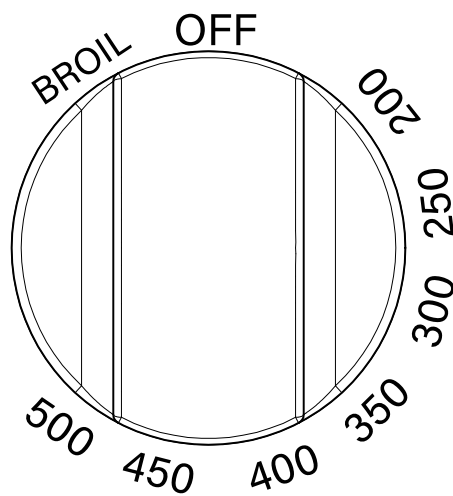

OPERATION

NOTE: Your appliance uses two different cooling fans. They protect internal components and surfaces. Sounds from these fans are normal and do not indicate a fault.

Oven Cooling Fan (not the convection fan)

- **Purpose:** Cools the control area, door, and electronics during/after baking or broiling.
- **When it runs:** Automatically turns on when internal sensors detect heat and may continue after the oven is turned off until temperatures drop.
- **What it's not:** This is separate from the convection fan used for cooking. It does not move air inside the food cavity for cooking performance.
- **What you'll notice:** A steady airflow sound from the top/rear. The fan may cycle on/off as the oven cools.

Induction Cooktop Cooling Fan

- **Purpose:** Cools the induction power modules (coils and electronics) to maintain performance and protect components.
- **When it runs:** May turn on quickly at high power settings, or after long cooking sessions, and can continue briefly after the cooktop is switched off until internal temperatures are safe. At low settings it may pulse as power cycles.
- **What you'll notice:** A soft whir from below the cooktop. Sound level may change with power and pan temperature.

Important Notes

- **Normal operation:** It is normal for either fan to continue running after cooking and to change speed while cooling.
- **Do not block vents:** Keep intake/exhaust areas and the space beneath/behind the appliance clear. Blocking airflow can reduce performance or trigger thermal limits.
- **Service check:** Contact ZLINE customer service at 1-614-777-5004 if a fan is unusually loud, scrapes/rattles, or runs continuously when the appliance is cool and unused.

OPERATION

OVEN VENTS

- The oven vent is located under the back splash on the back of the oven. Do not block the ducts in the oven vent when cooking in the oven. It is important that the flow of hot air from the oven and fresh air into the oven never be interrupted.
- Avoid touching the vent opening or nearby surfaces while the oven is on — they may become hot, which increases the risk of injury.
- **NOTE:** It is normal for steam or moisture to dispel from the oven vent and collect on the cooktop. This happens more often when baking foods that contain a lot of moisture. Condensation is more common in colder months due to the cooktop being colder than normal. Condensate water is a natural occurrence and is non-corrosive.



WARNING

INTERIOR OVEN SAFETY

Aluminum foil may also trap heat, causing a fire hazard. Do not use aluminum foil on any porcelain surface within the oven wall. Doing so may irreparably damage the porcelain. Use of aluminum foil on any part of the range may void the manufacturer's warranty.

OVEN FUNCTIONS AND FEATURES

BAKE

- Natural airflow baking occurs when heat is transferred into the oven from the bake burners located in the bottom of the oven cavity, below the drip pan. Heat is then circulated by natural airflow. This is a traditional bake setting.
- To activate, turn the oven on and choose a temperature between 200 °F to 500 °F (93 °C to 260 °C).
- **NOTE:** It typically takes 15–25 minutes to preheat to the desired temperature.
- To achieve optimal baking results, ZLINE recommends waiting until the oven is fully preheated before placing food inside.

OPERATION

CONVECTION BAKE

- Heat is generated by the bake burners located at the bottom of the oven cavity. A convection fan at the rear of the oven circulates the heated air to promote more even heat distribution around the food. Convection cooking typically allows for faster cooking, operation at lower temperatures, and more uniform results compared to traditional baking.
- To operate this mode, turn the oven on, select the desired temperature, then press the fan button on the front of the oven.
- For best results, place food on the center oven rack position. When cooking on multiple racks, stagger cookware to allow proper air circulation.
- When using convection bake, you may reduce the recipe temperature by approximately 25 °F (15 °C) or shorten the cooking time, as needed.
- For optimal convection baking results, allow the oven to fully preheat before placing food inside.

BROIL

- During broiling, heat radiates downward from the broil burner to provide even coverage and fast cooking.
- The broil temperature is 500 °F (260 °C).
- For best broiling results, place food on an upper oven rack position.
- Adjust the rack position as needed to achieve the desired level of browning while preventing excessive charring.
- **NOTE:** The oven door must remain closed during broiling.



WARNING

Carefully monitor food being cooked under the broiler, as this function works quickly and can burn food within only a few minutes.

OVEN COOKING

- Use care when opening the oven door. Let hot air or steam escape before removing or placing food.
- **DO NOT** heat unopened food containers. Pressure build-up may cause containers to burst and result in injury.

OPERATION

OVEN RACK PLACEMENT

- Insert the oven racks between the upper and lower rack guides at any of the available rack positions.
- To remove a rack, pull it out to the fully extended position, then lift the front of the rack slightly and pull it out of the sliding mechanism.
- **CAUTION:** Use care when installing or removing racks. The rack guides and sliding mechanisms may have sharp edges.
- Oven racks are designed to support up to 25.0 lb (11.0 kg).



WARNING Users should use caution with heavier food loads than those outlined above to limit risk of injury and/or damage to your range.

Take care to reset all cooktop/oven/broiler burner controls to the OFF position after use of the appliance.

CARE AND MAINTENANCE

REPLACING THE OVEN LIGHTS



WARNING

To prevent electrical shock or injury, make sure the oven and light bulbs are cool and power to the oven has been turned off before replacing light bulbs.

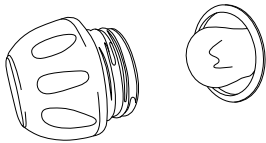

To replace the light bulbs (2) located at the upper left and bottom right corners of the oven, unscrew the protection cap that projects out inside the oven. **NOTE:** The light bulbs screw in, rather than plug in.

NOTE: Touching bulbs with your fingers may cause them to burn out. We recommend using protective gloves or a clean cloth for this process.



Visit www.zlineparts.com and search "SGP-108" to order a replacement.

CARE AND MAINTENANCE

CLEANING YOUR RANGE

- Do not attempt any of the following cleaning methods until all burners are off and the oven is completely cool. We also recommend disconnecting power before cleaning the unit to limit risk of electric shock.
- It is normal for moisture to form between the oven door's two glass panels, especially when cooking or baking foods with a lot of moisture. The range is designed with vents between the panes of glass; any moisture should dissipate within 12–24 hours.
- Clean only the parts listed in the manual.
- **DO NOT CLEAN DOOR GASKETS.** The door gasket is essential for a good seal. Care should be taken not to rub, damage, or move the gasket.
- Take care when using cleaning products in spray form: never direct the spray onto the electrical wiring, thermostat, and bulb.
- Acidic fluids such as tomato sauce or lemon juice should not be left on the cooktop for extended periods, as etching may occur. This type of damage is not covered under the manufacturer's warranty.
- **IMPORTANT:** During cleaning, never use abrasive cleaners. Scratches on the stainless steel surfaces are permanent. **DO NOT** clean the range when hot. Do not use bleach or alcohol wipes to clean stainless steel. Always follow label instructions on cleaning products.

STAINLESS STEEL

- To clean the stainless steel surface of the range, use warm sudsy water or a stainless steel cleaner or polish. Always wipe the surface in the direction of the grain. Follow product label instructions for cleaning stainless steel.
- **DO NOT** use a steel wool pad as it will scratch the surface. Do not use cleaners with chlorides or chlorines. Do not use harsh scrubbing cleaners.
- Use a clean, hot, damp cloth to remove soap. Dry with a dry, clean cloth.
- Use care not to rotate the knobs when cleaning to avoid the release of gas.
- For hard-to-reach stains, you can remove knobs by gripping them and carefully pulling them straight out. Clean and dry knobs completely before replacing, using care to put knobs on the correct valves where they were removed.

CARE AND MAINTENANCE

COOKTOP GLASS

- Before maintenance and cleaning, disconnect the appliance and allow cooling down. For reasons of hygiene and safety, this appliance must always be kept clean.
- To prevent the appliance from discoloring or staining, clean cooktop after each use, and wipe up acidic or sugary residue as soon as the appliance has cooled. Any food or liquid spills on the cooktop — or on the sides or bottom of the oven — must be cleaned up before cooking in order to avoid unpleasant smoke and/or the possibility of fire. For stuck residue, lay a warm, soapy towel on the spill for 5–10 minutes, lift it with a plastic scraper, then wipe.
- Choose spray formulas, not creams/pastes. Take care when using cleaning products in spray form: never direct the spray onto the electrical wiring, thermostat, and bulb.
- Clean with non-abrasive, ammonia-free spray or mild soap and water. Avoid abrasive tools. Abrasive cleaners may permanently change the surface appearance and are not covered under finish warranty. **NOTE:** Label should specify non-abrasive and ammonia-free (ideally “safe for coated/matte glass”).
- For daily cleaning, use warm water and a drop of mild dish soap. Wipe with a soft microfiber cloth, then rinse and dry.
- To degrease/remove fingerprints, use isopropyl alcohol (70–90%) on a microfiber cloth and wipe dry.



According to the U.S. Department of Agriculture: **DO NOT** hold foods at temperatures between 40 °F to 140 °F (4 °C to 60 °C) more than 2 hours. Cooking raw foods below 275 °F (135 °C) is not recommended.

CARE AND MAINTENANCE

DOOR HANDLE

- Clean with a warm soap and water solution; dry with a soft, lint-free cloth.
- Do not use abrasive cleaners or scrubbers; they will permanently damage the finish.

OVEN DOOR

- Use soap and water to thoroughly clean the top, sides, and front of the door. Rinse well. Use a glass cleaner to clean the glass on the outside of the door. Do not use oven cleaners, cleansing powders, or harsh abrasives on the outside of the door.
- Do not allow excess water to run into any holes or slots in the door. Any soap left on the liner causes additional stains when the oven is heated.

OVEN RACKS

Clean oven racks with a warm soap and water solution. To clean heavy soil, use a scouring pad such as steel wool with plenty of water.

TROUBLESHOOTING

- Please review this list for common troubleshooting tips before calling for service, as this may save you time and money.
- This list contains frequently encountered problems that are not results of faulty workmanship or material use.
- Your product may not have some of the features described here.



WARNING If a problem cannot be resolved after following the instructions in the manuals, please contact ZLINE customer service at 1-614-777-5004. Never attempt to repair or disassemble the internal electrical wiring of your range.

ERROR CODE	POSSIBLE CAUSE	POSSIBLE SOLUTION
F/1 – Power Board Fault/ Communication Error: The main power board is not functioning correctly or communication between control boards has failed.	Internal electronic failure, loose wiring connection.	Switch the appliance off at the circuit breaker, wait 1 minute, then restart. If the code reappears, contact service.
F/3 – NTC Sensor Failure	The temperature sensor (NTC) inside the induction coil has failed or is not connected properly.	Do not attempt repair. Contact ZLINE customer service.
F/4 – IGBT Failure	The Insulated Gate Bipolar Transistor (IGBT), which controls power to the induction coil, is malfunctioning.	Turn off the range immediately and contact service. Continued operation may damage internal electronics.
E/1 – Coil Temperature Sensor Overheated: The temperature sensor (NTC) on the induction coil has detected excessive heat.	Inadequate ventilation, cookware blocking airflow, or prolonged high-power operation.	Allow the cooktop to cool. Check that air vents are clear. If the code persists, contact ZLINE customer service.

TROUBLESHOOTING

ERROR CODE	POSSIBLE CAUSE	POSSIBLE SOLUTION
E/2 – IGBT Overheating: The Insulated Gate Bipolar Transistor (IGBT), which controls power to the induction coil, has overheated.	Prolonged cooking at maximum power, insufficient cooling airflow.	Allow the cooktop to cool and ensure ventilation is unobstructed. If the code persists, contact ZLINE customer service.
E/3 – High Voltage Protection	Input voltage is too high for safe operation.	Turn off the appliance. Contact a qualified electrician to verify your home's electrical supply.
E/4 – Undervoltage Protection	Input voltage is too low for safe operation.	Verify electrical supply. Do not use the cooktop until voltage is stable. If the problem continues, contact an electrician.
E/5 – Coil Temperature Sensor (NTC) Disconnected / Moved	The sensor on the induction coil is out of position.	Contact ZLINE customer service to inspect and reposition or replace the sensor.

TROUBLESHOOTING

SYMPTOM	POSSIBLE CAUSE	POSSIBLE SOLUTION
"Cracking" or "popping" sound is heard coming from appliance.	This is the sound of metal heating and cooling.	This is normal for oven operation.
Steam/condensation is coming from the back splash oven vent.	Cooking foods high in moisture or if the ambient temperature is cold.	Condensate water is a natural occurrence and is non-corrosive.
Nothing works.	Power supply is not energized.	Have an electrician check the power supply, including the house circuit breaker, wiring and fuses.
Foods over-cooked or under-cooked.	Incorrect cooking temperature.	Adjust temperature, or rack position.
	Calibration of oven temperature.	Contact ZLINE customer service.
Cooktop does not power on.	-	Confirm the unit is properly connected to a power supply.
Cooktop will not heat.	-	Verify cookware is induction-compatible (a magnet should stick firmly to the bottom).
		Ensure cookware is flat-bottomed and centered on the cooking zone.
		If the display shows "E", the cookware is not detected.
Oven will not heat.	Faulty thermostat or heating element.	Contact ZLINE customer service.

TROUBLESHOOTING

SYMPTOM	POSSIBLE CAUSE/SOLUTION
Cooking takes longer than expected.	Cookware may be too thin, warped, or the wrong size for the zone.
	Using cookware smaller than the marked cooking zone may reduce efficiency.
	Verify the power level is set correctly (higher levels for rapid heating).
Noise during operation.	Low humming, clicking, or fan noise is normal.
	A high-pitched whine may occur with lightweight cookware; try using heavier pans instead.
	The cooling fan continues after cooking—this is normal and will stop once the internal components cool.
Surface remains hot after use.	The cooktop surface retains residual heat from cookware.
	" <i>H</i> " indicator will remain active until safe to touch.
Display flickers or dims.	May occur if the household voltage fluctuates.
	Check with a qualified electrician, if persistent.

WARRANTY

COVERAGE

ZLINE Kitchen and Bath ("ZLINE") induction ranges have a one year parts and service warranty.

ZLINE warranty periods begin from the original date of product delivery and solely cover the original purchaser of the product, delivered new and in its original carton. The limited warranty covers all parts and labor for necessary repairs if any part of the product, or the product itself, proves to be defective in materials or workmanship. The product must be deemed serviceable via troubleshooting with the ZLINE Customer Experience team. All service on ZLINE products under warranty must be performed by ZLINE-approved and ZLINE-certified service providers unless otherwise specified by ZLINE. Service will be provided during normal business hours. Products must be unobstructed and accessible to the service provider at the time of service. ZLINE's liability is limited to the original purchase price of the product. Additional injuries, losses, damages, or other inconveniences caused by product malfunction or defects in materials are not covered under the terms of this warranty.

TERMS

ZLINE warranties apply only to the original purchaser of a ZLINE product installed for normal residential use. This is defined as a single-family, residential dwelling in a non-commercial setting. Any warranty claim stemming from installation, operation, or any other use within a commercial setting is not covered under this limited warranty. Commercial settings include, but are not limited to: schools, churches, hotels, restaurants, vacation rentals such as Airbnb, daycare centers, private clubs, fire stations, common areas in multi-family dwellings, nursing homes, food service locations, and institutional food service locations such as hospitals or correctional facilities.

This warranty is non-transferable and will not under any circumstance be extended based on the date of installation — the warranty period takes effect from the date of delivery and only covers the original purchaser. The warranty applies only to products installed in the contiguous United States and the District of Columbia. Failure to secure certified warranty service per these terms will result in a forfeiture of the remaining warranty. Out-of-pocket payments will not be reimbursed unless prior approval is received from ZLINE and/or ZLINE-certified service contract partners. Unapproved out-of-pocket payments for service will not be reimbursed. All warranty procedures must be followed to maintain warranty coverage.

WARRANTY

If a product qualifies within the service window provided under these warranty terms, and ZLINE is unable to repair the product or a defective part of the product after a reasonable number of attempts, ZLINE reserves the right to offer to replace the defective part or the product or provide the original purchaser a full refund of the purchase price of the product (not including installation, removal, or other charges that were not included in the original purchase price). The original purchaser of the product must provide the original proof of purchase, including the purchase date, when filing a claim to obtain replacement parts, service, or refunds. Additionally, the original purchaser of the product must provide the serial number of the product when filing a claim to obtain replacement parts, service, or refunds.

This warranty shall not apply to any ZLINE product in which the original factory serial number has been removed, altered, or cannot be readily determined for any reason. Further, ZLINE is not responsible for damage resulting from, but not limited to: shipment, delivery, or improper installation; negligence or improper maintenance, misuse, or abuse of the product; unauthorized alteration, modification, or tampering with the product; accident, fire, floods, pest infestations, pandemics, natural disasters, or any other unpreventable or unexplained acts of nature, commonly referred to as "acts of God"; flare-up fires or damages caused by improper electric supply, electrical line current, voltage, or power surges; and service to correct installation not in accordance with the instructions contained in ZLINE's product manuals and/or with local government codes.

This warranty does not apply to aesthetic damage, scratches, or natural wear caused by normal use; second-hand, open box products, or products purchased from an unauthorized retailer; and damages or issues stemming from alteration or tampering with the range, including, but not limited to, painting any portion of the product's interior or exterior and cutting the supplied power cord to manually hardwire the product.

In the event service is dispatched, and it is discovered that the reported issue is not covered under warranty based on the disclaimers above, the customer will be responsible for all service fees. Failure to pay these fees will result in the forfeiture of remaining warranty coverage.

WARRANTY

Information contained within ZLINE's installation and user manuals, in addition to product information included on ZLINE's website and all related digital listings, do not cover every possible condition and situation that may occur during the installation or operation of ZLINE products.

ZLINE reserves the right to make changes at any time to its products when considered safe, necessary, and useful. Always check the ZLINE website for the most up-to-date version of its product manuals: www.zlinekitchen.com/pages/manuals.

Do not install or operate any ZLINE product if it has missing or broken parts or if it arrives damaged due to shipping. If ZLINE products arrive damaged, contact ZLINE Customer Experience at 1-614-777-5004 for help. Failure to report a damaged appliance prior to installation or operation may void the warranty.

ZLINE disclaims responsibility for damage or injury caused by improper installation or use of any of its products. ZLINE is under no obligation, by law or otherwise, to provide concessions, including repairs, prorates, rebates, discounts, or replacements, once the warranty has expired.

SERIAL NUMBER LOCATION

Please write down the model number (highlighted in the image below as the "SKU") and serial number of your appliance. Both numbers are located on the rating tag located on the right front edge of your range. Do not remove permanently affixed labels, warnings, or plates from the product. This will void the warranty. You may also consider attaching your receipt or proof of purchase to this manual.

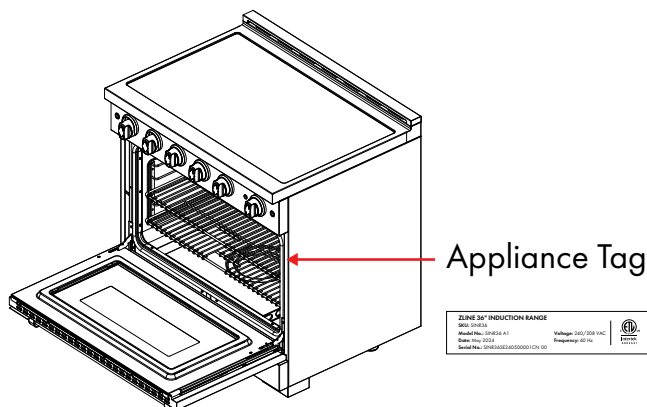

ZLINE 30" INDUCTION RANGE SKU: ZL3010 Model No.: ZL3010-A1 Date: 10/2024 Serial No.: 10453022405000101-01	Voltage: 240/208 VAC Frequency: 60 Hz	 UL Listed	Confirms to: • Underwriters Laboratories (UL) Standard for Electric Ranges • CSA E100 (UL E100) 10453022405000101 • International Council on Harmonization (IEC) Standard IEC 60730-1-2 (UL 1988) • C22.2 No. 250.1 (UL 60901)	This device complies with part 15 of the FCC Rules. Operation is subject to the following two conditions: 1) This device may not cause harmful interference, and 2) This device must accept any interference received, including interference that may cause undesired operation.	ZLINE 1-614-777-5004
--	--	--	--	--	--------------------------------

WARRANTY



SERVICE

For warranty service, please contact our Customer Service team at 1-614-777-5004 or visit www.zlinekitchen.com/contact to utilize our online Customer Experience Portal.



Scan the QR code to view the most up-to-date version of our Installation Manual and User Manual.



Need to purchase a part or accessory for your ZLINE product?
Visit www.zlineparts.com, ZLINE's official parts distribution partner.

1.3.0

zlinekitchen.com

1-614-777-5004

contact@zlinekitchen.com

ZLINE
ATTAINABLE LUXURY®